

**DATA SHEET**

# AP172-317LF: Linear Power Amplifier

## Features

- High linearity @ 24 dBm
- High gain 33 dB
- 802.11b/g compliant
- 1800–2500 MHz operation
- Built-in level detector
- 27 dBm  $P_1$  dB @ 2.4 GHz
- Uses single DC bias supply
- Low-cost plastic package
- Available on tape and reel
- Available lead (Pb)-free and RoHS-compliant

## Description

The AP172-317LF is a linear, high-gain, medium-power amplifier designed for low voltage operation in a 2.4–2.5 GHz band having linear and high-efficiency performance with 802.11b/g signals and built-in level detection circuit. The device is manufactured on an advanced InGaP HBT process and housed in a 16-pin 4 x 4 mm micro lead package.

**NEW** Skyworks offers lead (Pb)-free, RoHS (Restriction of Hazardous Substances)-compliant packaging.



## Simplified Block Diagram

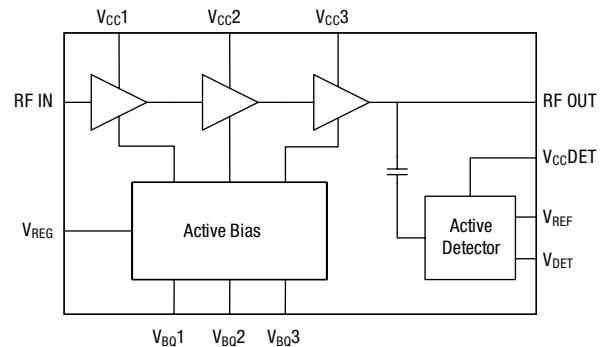

## Absolute Maximum Ratings

Characteristic	Value
RF input power	20 dBm
Supply current	600 mA
Supply voltage	5 V
Operating temperature	-40 °C to +85 °C
Storage temperature	-65 °C to +125 °C

Performance is guaranteed only under the conditions listed in the specifications table and is not guaranteed under the full range(s) described by the Absolute Maximum specifications. Exceeding any of the absolute maximum/minimum specifications may result in permanent damage to the device and will void the warranty.

**CAUTION:** Although this device is designed to be as robust as possible, ESD (Electrostatic Discharge) can damage this device. This device must be protected at all times from ESD. Static charges may easily produce potentials of several kilovolts on the human body or equipment, which can discharge without detection. Industry-standard ESD precautions must be employed at all times.

**Electrical Specifications at 25 °C (0, 3 V)****Z<sub>0</sub> = 50 Ω, unless otherwise noted**

Parameter	Condition	Symbol	Min.	Typ.	Max.	Unit
Frequency range		MHz	1800		2500	dB
Small signal gain	F = 2.45 GHz	S <sub>21</sub>	31	33		dB
Output power at 1 dB compression	F = 2.45 GHz	P <sub>1 dB</sub>	26	27		dBm
Linear output power <sup>(1)</sup>	F = 2.45 GHz, I <sub>C</sub> = 240 mA	P <sub>OUT</sub>	23	24.5		dBm
First side lobe <sup>(1)</sup>	F = 2.45 GHz, I <sub>C</sub> = 220 mA, P <sub>OUT</sub> = 23 dBm			-35		dBc
Second side lobe <sup>(1)</sup>	F = 2.45 GHz, I <sub>C</sub> = 220 mA, P <sub>OUT</sub> = 23 dBm			-54		dBc
Operating voltage	Amplifier DC voltage	V <sub>D</sub>	2.5	3.3	4.5	V
Reverse isolation		isol.		30		dB
Current consumption	P <sub>OUT</sub> = 24.0 dBm P <sub>OUT</sub> = 22.5 dBm P <sub>OUT</sub> = 17 dBm Quiescent	I <sub>q0</sub>		240 220 140 70		mA mA mA mA
Detector supply voltage	V <sub>CCDet</sub>		2	2.5	4	V
Detector supply current	V <sub>CCDet</sub> = 2.5 V	I <sub>CCDet</sub>		2		mA
Detector output voltage	V <sub>CCDet</sub> = 2.5 V P <sub>OUT</sub> = 22.5 dBm	V <sub>Det sen</sub> - V <sub>REF</sub>		0.43		V

V<sub>CC</sub> = 3.3 V, I<sub>C</sub> = 70 mA (unless otherwise specified)

1. Specifications are defined for the evaluation board with the 802.11b signal at 11 Mbit/s and having cosine (0.95) filtering.

**Typical Performance Data**

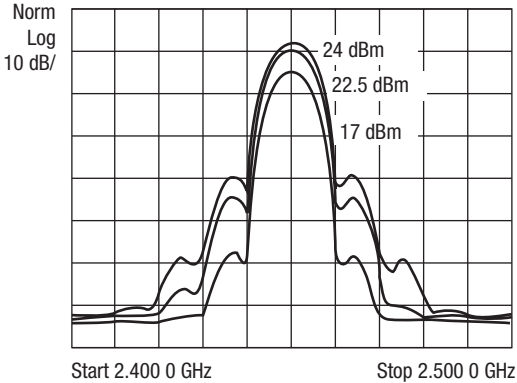

**Spectrum of Output Signals at Different Power Levels**

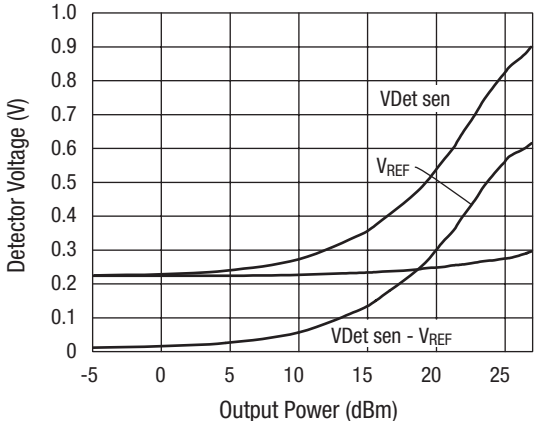

**Built-In Detector Responses at  $V_{CCDet} = 2.5 V$**

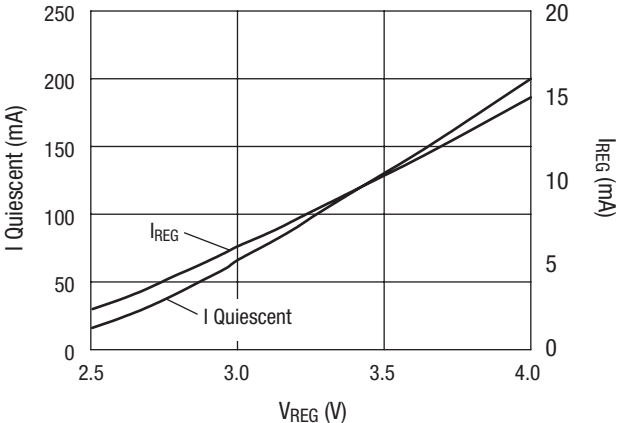

### Pin Out

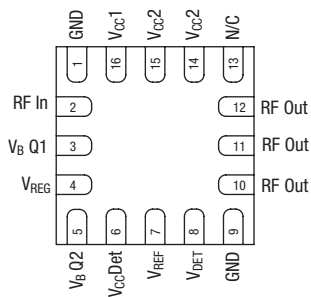

### -317

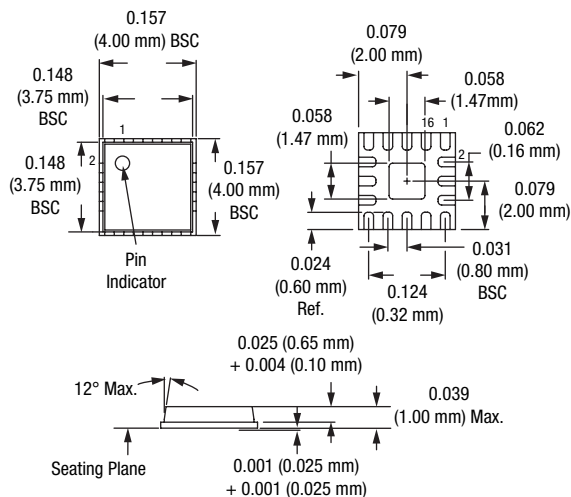

### Recommended Solder Reflow Profiles

Refer to the [“Recommended Solder Reflow Profile”](#) Application Note.

### Tape and Reel Information

Refer to the [“Discrete Devices and IC Switch/Attenuators Tape and Reel Package Orientation”](#) Application Note.

### Pin Description

Pin Number	Pin Name	Description
2	J <sub>1</sub> , J <sub>2</sub>	RF input – RF input, 50 Ω (nominal). An external DC block is required
1, 9	GND	Equipotential point – Internal circuit common, which must be connected to the pcb ground or common via the lowest possible impedance.
3	V <sub>B</sub> Q1	Bias adjust – 2nd stage – Quiescent current of the second amplifier stage as measured at V <sub>CC2</sub> can be increased by adding a resistor between this pin and V <sub>REG</sub> . This pin may be left open if the nominal value of collector current for the second stage is acceptable. This pin should not be connected to ground.
4	V <sub>REG</sub>	Regulated voltage input – The voltage applied to this pin supplies the active bias stages for the power amplifier stages. The nominal applied voltage is equal to V <sub>CC</sub> . The power amplifier stages are disabled if this pin is open.
5	V <sub>B</sub> Q2	Bias adjust – output stage – Quiescent current of the output amplifier stage as measured at V <sub>CC2</sub> can be increased by adding a resistor between this pin and V <sub>REG</sub> . This pin may be left open if the nominal value of collector current for the output stage is acceptable. This pin should not be connected to ground.
6	V <sub>CC</sub> DET	Active detector supply voltage – The voltage applied to this pin powers the active detector circuit. The nominal applied value is equal to V <sub>CC</sub> . The active detector circuit is disabled if this pin is connected to ground.
7	V <sub>REF</sub>	Active detector reference voltage output – The DC voltage produced at this pin can be used to track the temperature drift of the voltage from V <sub>DET</sub> . This voltage can be used to temperature compensate the voltage from V <sub>DET</sub> .
8	V <sub>DET</sub>	Active detector output voltage – Detected output voltage which varies proportionally to the output power from the RF Out pins.
10, 11, 12	RF Out	RF output – RF outputs, internally connected to share signal currents. An internally-generated DC voltage is present at this pin, so a DC blocking capacitor should be included in the output circuit.
13	NC	No internal connection
14, 15	V <sub>CC2</sub>	Collector supply voltage 2 – The voltage applied to these pins supplies the collector of the 2nd amplifier stage. These pins are internally connected to share current.
16	V <sub>CC1</sub>	Collector supply voltage 1 – The voltage applied to this pin supplies the collector of the input amplifier stage.

### Evaluation Board Schematic

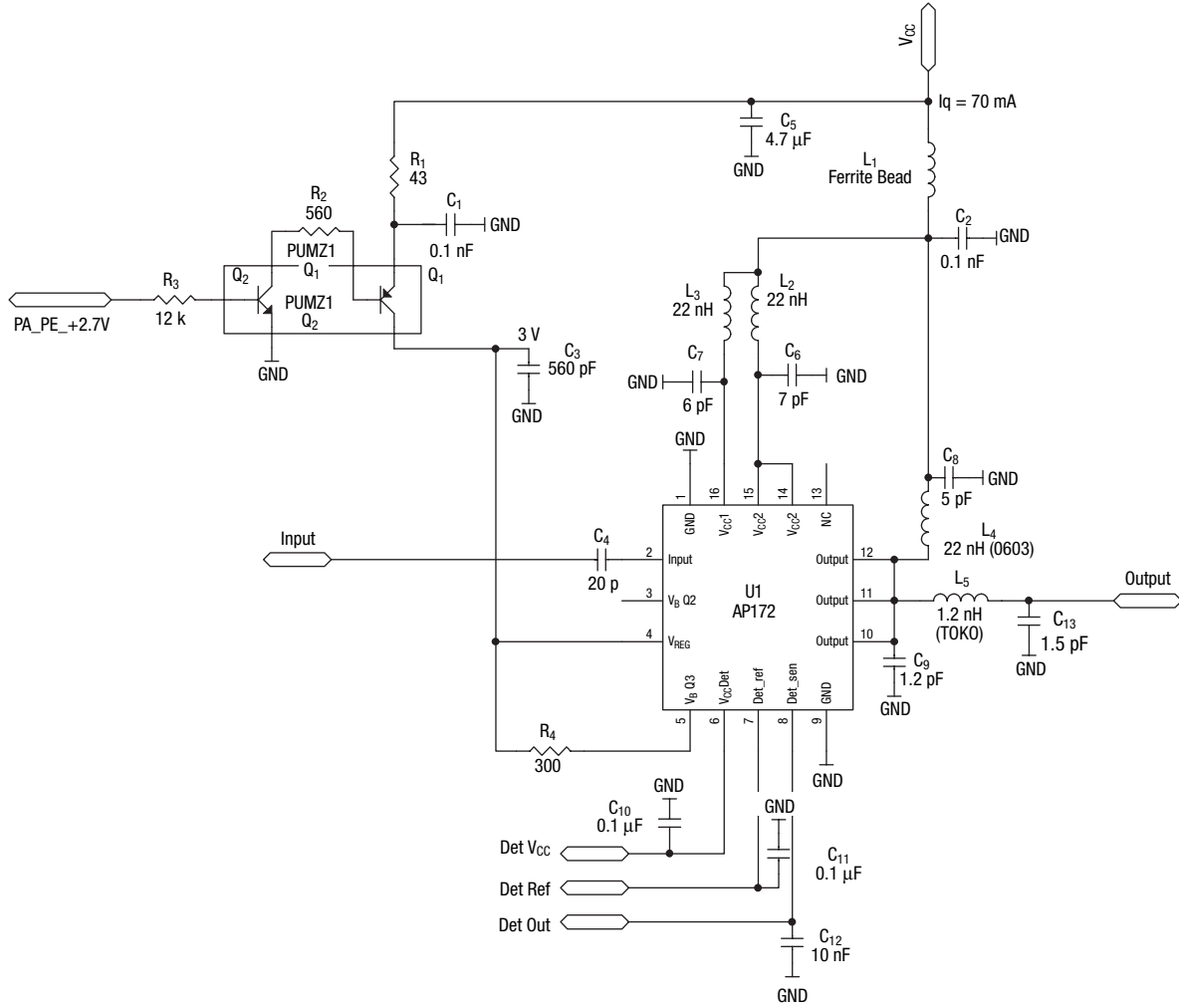

### Evaluation Board Layout (Top View)

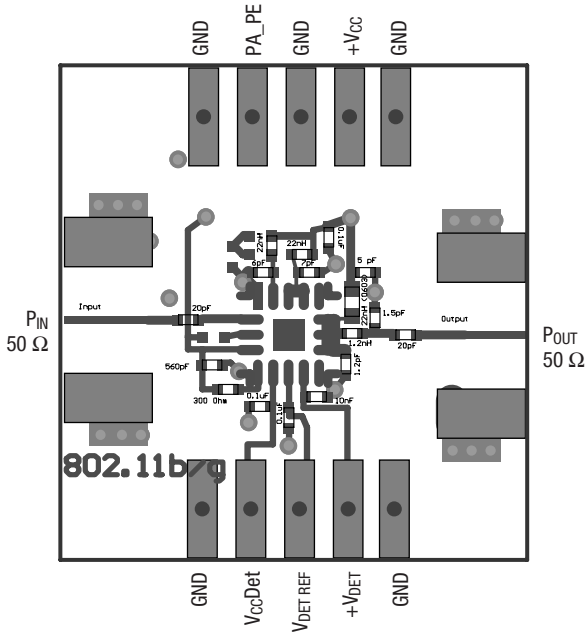

### Evaluation Board Layout (Bottom View)

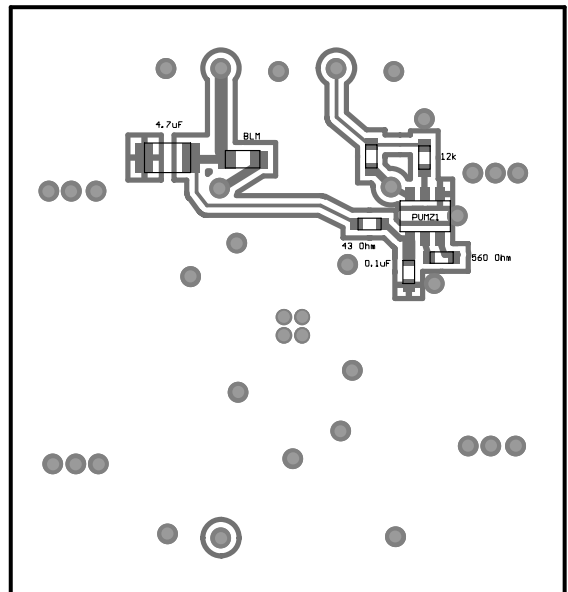

Copyright © 2002, 2003, 2004, 2005, 2006, Skyworks Solutions, Inc. All Rights Reserved.

Information in this document is provided in connection with Skyworks Solutions, Inc. ("Skyworks") products or services. These materials, including the information contained herein, are provided by Skyworks as a service to its customers and may be used for informational purposes only by the customer. Skyworks assumes no responsibility for errors or omissions in these materials or the information contained herein. Skyworks may change its documentation, products, services, specifications or product descriptions at any time, without notice. Skyworks makes no commitment to update the materials or information and shall have no responsibility whatsoever for conflicts, incompatibilities, or other difficulties arising from any future changes.

No license, whether express, implied, by estoppel or otherwise, is granted to any intellectual property rights by this document. Skyworks assumes no liability for any materials, products or information provided hereunder, including the sale, distribution, reproduction or use of Skyworks products, information or materials, except as may be provided in Skyworks Terms and Conditions of Sale.

THE MATERIALS, PRODUCTS AND INFORMATION ARE PROVIDED "AS IS" WITHOUT WARRANTY OF ANY KIND, WHETHER EXPRESS, IMPLIED, STATUTORY, OR OTHERWISE, INCLUDING FITNESS FOR A PARTICULAR PURPOSE OR USE, MERCHANTABILITY, PERFORMANCE, QUALITY OR NON-INFRINGEMENT OF ANY INTELLECTUAL PROPERTY RIGHT; ALL SUCH WARRANTIES ARE HEREBY EXPRESSLY DISCLAIMED. SKYWORKS DOES NOT WARRANT THE ACCURACY OR COMPLETENESS OF THE INFORMATION, TEXT, GRAPHICS OR OTHER ITEMS CONTAINED WITHIN THESE MATERIALS. SKYWORKS SHALL NOT BE LIABLE FOR ANY DAMAGES, INCLUDING BUT NOT LIMITED TO ANY SPECIAL, INDIRECT, INCIDENTAL, STATUTORY, OR CONSEQUENTIAL DAMAGES, INCLUDING WITHOUT LIMITATION, LOST REVENUES OR LOST PROFITS THAT MAY RESULT FROM THE USE OF THE MATERIALS OR INFORMATION, WHETHER OR NOT THE RECIPIENT OF MATERIALS HAS BEEN ADVISED OF THE POSSIBILITY OF SUCH DAMAGE.

Skyworks products are not intended for use in medical, lifesaving or life-sustaining applications, or other equipment in which the failure of the Skyworks products could lead to personal injury, death, physical or environmental damage. Skyworks customers using or selling Skyworks products for use in such applications do so at their own risk and agree to fully indemnify Skyworks for any damages resulting from such improper use or sale.

Customers are responsible for their products and applications using Skyworks products, which may deviate from published specifications as a result of design defects, errors, or operation of products outside of published parameters or design specifications. Customers should include design and operating safeguards to minimize these and other risks. Skyworks assumes no liability for applications assistance, customer product design, or damage to any equipment resulting from the use of Skyworks products outside of stated published specifications or parameters.

Skyworks, the Skyworks symbol, and "Breakthrough Simplicity" are trademarks or registered trademarks of Skyworks Solutions, Inc., in the United States and other countries. Third-party brands and names are for identification purposes only, and are the property of their respective owners. Additional information, including relevant terms and conditions, posted at [www.skyworksinc.com](http://www.skyworksinc.com), are incorporated by reference.