

SUPPLY VOLTAGE MONITOR

ISSUE 4 – JULY 2006

ZM33164-3

DEVICE DESCRIPTION

The ZM33164-3 is a three terminal under voltage monitor circuit for use in microprocessor systems. The threshold voltage of the device has been set to 2.68 volts making it ideal for 3 volt circuits.

Included in the device is a precise voltage reference and a comparator with built in hysteresis to prevent erratic operation. The ZM33164-3 features an open collector output capable of sinking at least 10mA which only requires a single external resistor to interface to following circuits.

Operation of the device is guaranteed from one volt upwards, from this level to the device threshold voltage the output is held low providing a power on reset function. Should the supply voltage, once established, at any time drop below the threshold level then the output again will pull low.

The device is available in a TO92 package for through hole applications as well as SOT223 for surface mount requirements.

FEATURES

- SOT223 and TO92 packages
- Power on reset generator
- Automatic reset generation
- Low standby current
- Guaranteed operation from 1 volt
- Wide supply voltage range
- Internal clamp diode to discharge delay capacitor
- 2.68 volt threshold for 3 volt logic
- 60mV hysteresis prevents erratic operation

APPLICATIONS

- Microprocessor systems
- Computers
- Computer peripherals
- Instrumentation
- Automotive
- Battery powered equipment

SCHEMATIC DIAGRAM

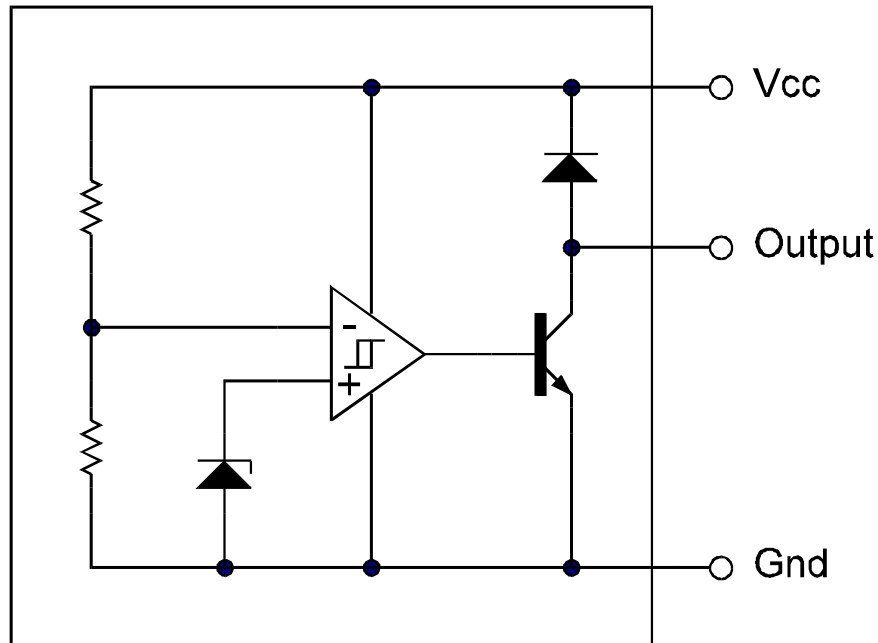

ZM33164-3

TYPICAL CHARACTERISTICS

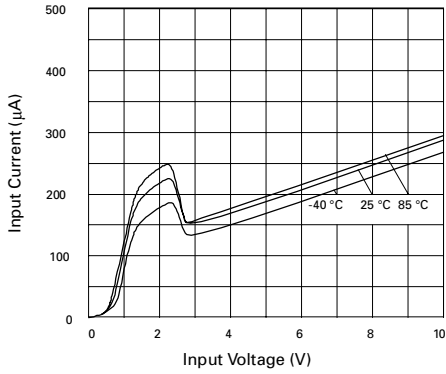

Input Current vs. Input Voltage

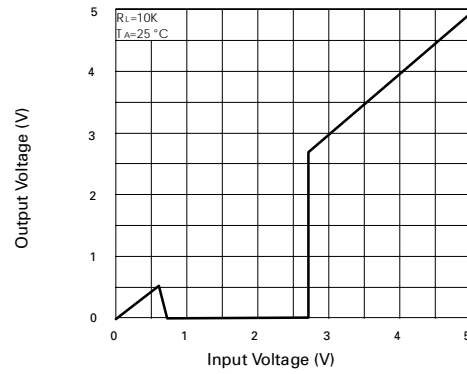

Output Voltage vs. Input Voltage

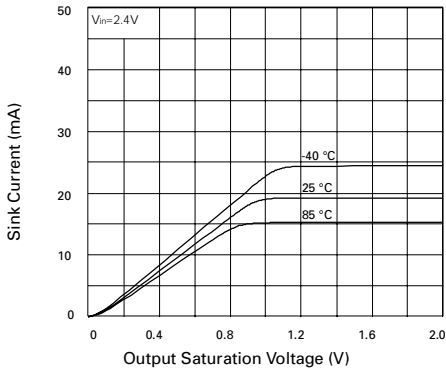

Output Saturation Voltage vs. Sink Current

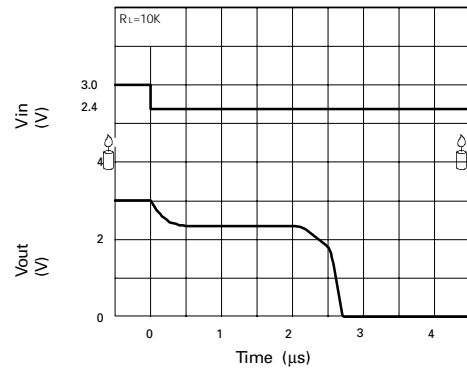

Reset Delay Time

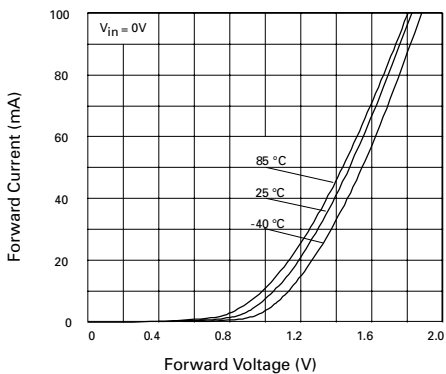

Clamp Diode Forward Current vs. Voltage

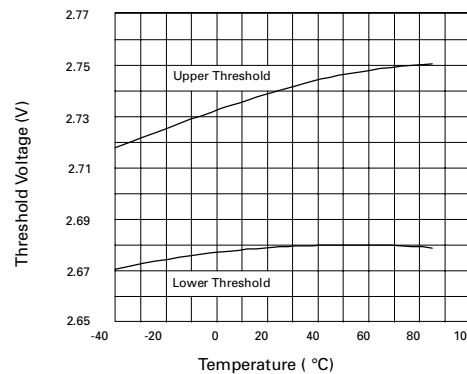

Threshold Voltage vs. Temperature

ZM33164-3

ABSOLUTE MAXIMUM RATING

Input Supply Voltage	-1 to 12V	Power Dissipation	
Offstate Output Voltage	12V	TO92	780mW
Onstate Output		SOT223	2W(Note 2)
Sink Current(Note 1)	Internally limited		
Clamp diode			
Forward Current(Note 1)	100mA		
Operating junction temperature	150°C		
Operating Temperature	-40 to 85°C		
Storage Temperature	-65 to 150°C		

TEST CONDITIONS

($T_{amb}=25^{\circ}\text{C}$ for typical values, $T_{amb}=-40$ to 85°C for min/max values (Note3))

COMPARATOR

PARAMETER	SYMBOL	MIN	TYP.	MAX.	UNITS
Threshold Voltage High state output (V _{cc} increasing)	V _{IH}	2.55	2.71	2.8	V
Threshold Voltage Low state output (V _{cc} decreasing)	V _{IL}	2.55	2.65	2.8	V
Hysteresis	V _H	0.03	0.06	0.15	V

OUTPUT

Output sink saturation: (V _{cc} =2.4V, I _{sink} =8.0mA)	V _{OL}		0.46	1.0	V
(V _{cc} =2.4V, I _{sink} =2.0mA)			0.15	0.4	V
(V _{cc} =1.0V, I _{sink} =0.1mA)				0.25	V
Onstate output sink current (V _{cc} , Output=2.4V)	I _{sink}	10	20	60	mA
Offstate output leakage current (V _{cc} , Output=3V)	I _{oh}		0.02	0.5	μA
Clamp diode forward voltage (I _f =10mA)	V _f	0.6	1.2	1.5	V
Propagation delay (V _{in} 3V to 2.4V, R _I =10k, T _{amb} =25°C)	T _d		2.5		μs

TOTAL DEVICE

Operating input voltage range	V _{cc}	1.0 to 10			V
Quiescent input current (V _{cc} =3V)	I _q		125	190	μA

ZM33164-3

TIMING DIAGRAM

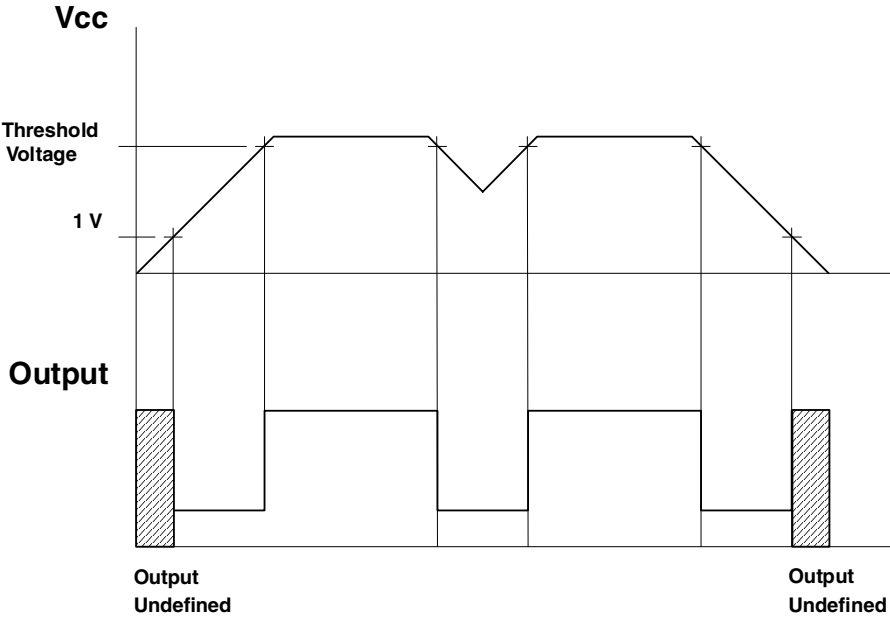

APPLICATION CIRCUIT

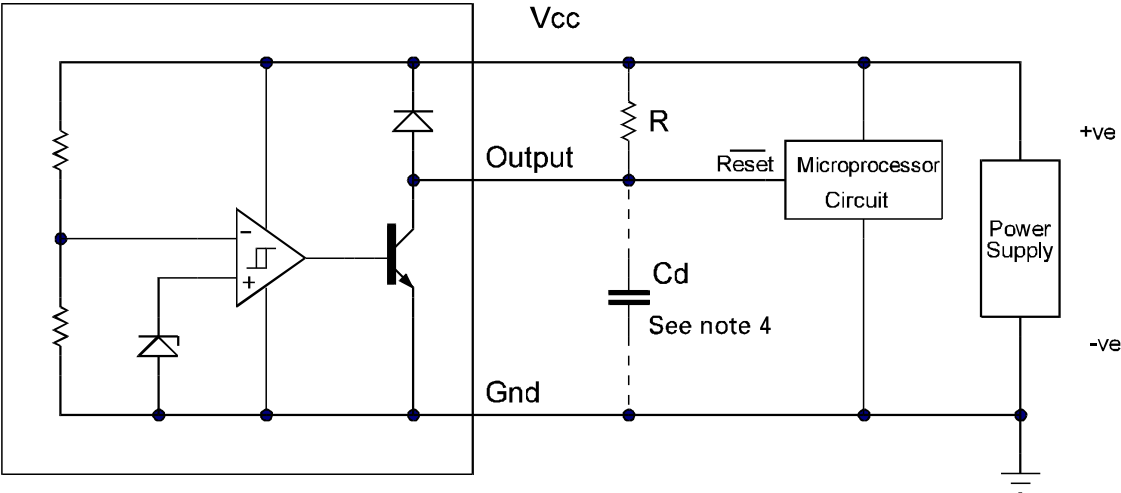

Note 4: A time delayed reset can be accomplished with the additional Cd.

$$T_{DY} = RCd \ln \left(\frac{1}{1 - \frac{V_{TH(mpu)}}{V_{in}}} \right)$$

T_{DY} = Time (Seconds)
 V_{TH} = Microprocessor Reset Threshold
 V_{in} = Power Supply Voltage

ZM33164-3

CONNECTION DIAGRAMS

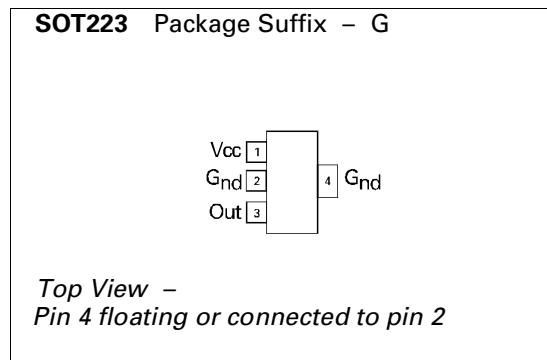
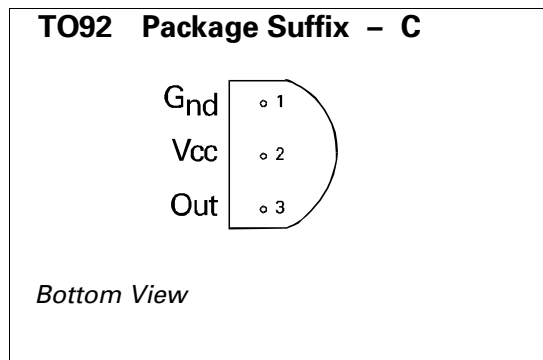

ORDERING INFORMATION

Part Number	Package	Part Mark
ZM331643G	SOT223	ZM331643
ZM331643C	TO92	ZM331643

Europe

Zetex GmbH
Streitfeldstraße 19
D-81673 München
Germany

Telefon: (49) 89 45 49 49 0
Fax: (49) 89 45 49 49 49
europe.sales@zetex.com

Americas

Zetex Inc
700 Veterans Memorial Highway
Hauppauge, NY 11788
USA

Telephone: (1) 631 360 2222
Fax: (1) 631 360 8222
usa.sales@zetex.com

Asia Pacific

Zetex (Asia Ltd)
3701-04 Metroplaza Tower 1
Hing Fong Road, Kwai Fong
Hong Kong

Telephone: (852) 26100 611
Fax: (852) 24250 494
asia.sales@zetex.com

Corporate Headquarters

Zetex Semiconductors plc
Zetex Technology Park, Chadderton
Oldham, OL9 9LL
United Kingdom

Telephone: (44) 161 622 4444
Fax: (44) 161 622 4446
hq@zetex.com

For international sales offices visit www.zetex.com/offices

Zetex products are distributed worldwide. For details, see www.zetex.com/salesnetwork

This publication is issued to provide outline information only which (unless agreed by the company in writing) may not be used, applied or reproduced for any purpose or form part of any order or contact or be regarded as a representation relating to the products or services concerned. The company reserves the right to alter without notice the specification, design, price or conditions of supply of any product or service.

Issue 4 - July 2006

© Zetex Semiconductors plc 2006

www.zetex.com