



LH4011/LH4011C Fast Open Loop Buffer

General Description

The LH4011 is a very high speed, FET input, voltage follower/buffer designed to provide high current drive at frequencies from DC to over 150 MHz. The LH4011/LH4011C will provide ± 200 mA into 50Ω loads (± 500 mA peak) at slew rates of 5000 V/ μ s. In addition, it exhibits excellent phase linearity.

The LH4011 is intended to fulfill a wide range of buffer applications. Due to its high speed it does not degrade the system performance. Its high output current makes it adequate for most loads. Only a single $+10$ V supply is needed for a 5 V_{pp} video signal. In addition, the LH4011 can continuously drive 50Ω coaxial cables.

These devices are constructed using specially selected junction FET's and active laser trimming to achieve guaranteed performance specifications. The LH4011K is specified for operation from -55°C to $+125^\circ\text{C}$; whereas, the LH4011CK is specified from -25°C to $+85^\circ\text{C}$. LH4011K and LH4011CK are available in a 5W 8-pin TO-3 package.

The LH4011CT is specified for operation from -25°C to $+85^\circ\text{C}$ and is available in an 11-pin TO-220 package.

Features

- Fast 5000V/ μ s
- Wide range single or dual supply operation
- Wide bandwidth DC to 160 MHz
- High output drive ± 10 V with 50Ω load
- Low phase non-linearity $< 2^\circ$
- Fast rise times < 2 ns
- High input resistance $> 10^{10}\Omega$
- Pin compatible with LH0063

Applications

- High speed line drivers
- Video impedance transformation
- Op amp isolation buffers
- Yoke driver for high resolution CRT
- High impedance input buffer

Connection Diagrams

Metal Can Package (TO-3), 8-Pin

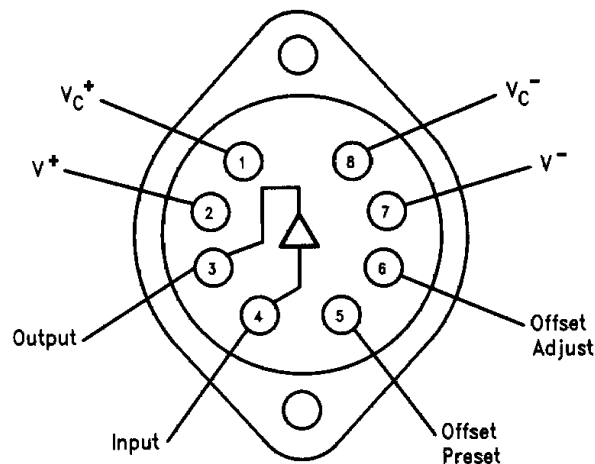

Top View

Note: Case is Electrically Isolated

Order Number LH4011K or LH4011CK
See NS Package Number K08A

TL/K/9423-1

Plastic Package (TO-220), 11-Pin

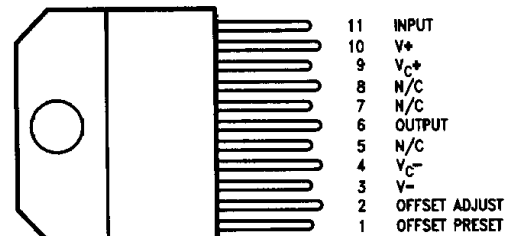

Top View

Note: Metal Tab is Electrically Isolated

Order Number LH4011CT
See NS Package Number TA11B

TL/K/9423-19

Absolute Maximum Ratings

If Military/Aerospace specified devices are required, please contact the National Semiconductor Sales Office/Distributors for availability and specifications.

Supply Voltage ($V^+ - V^-$)	40V
Maximum Power Dissipation (See Curves)	3.2W
Maximum Junction Temperature	175°C
Input Voltage	Equal to Supplies
Continuous Output Current	± 200 mA

Peak Output Current	± 500 mA
Operating Temperature Range	
LH4011	-55°C to +125°C
LH4011C	-25°C to +85°C
Storage Temperature Range	-65°C to +150°C
Lead Temperature	
(Soldering, 10 seconds)	300°C
ESD	TBD

DC Electrical Characteristics

$V_S = \pm 15V$, $R_S = R_L = 50\Omega$, $T_A = 25^\circ C$ unless otherwise specified (Note 1)

Symbol	Parameter	Conditions	LH4011			Units (Max Unless Otherwise Noted)
			Typical	Tested Limit (Note 2)	Design Limit (Note 3)	
V_{OS}	Output Offset	$R_L = 50\Omega$ $R_S < 100\text{ k}\Omega$ (Note 4)	10	25 100		mV
$\Delta V_{OS}/\Delta T$	Aver. Temp. Coeff. of Output Offset Voltage	$R_S < 100\text{ K}\Omega$ $T_{MIN} < T_A < T_{MAX}$	300			$\mu V/^\circ C$
I_B	Input Bias Current	(Note 4)	10	30 100		nA
A_v	Voltage Gain	$V_{IN} \pm 10V$, $R_L = 1\text{ k}\Omega$ $R_S < 100\text{ k}\Omega$	0.95	0.94 0.92		V/V (Min)
A_v	Voltage Gain	$V_{IN} = \pm 10V$, $R_L = 50\Omega$ $R_S < 100\text{ k}\Omega$	0.94	0.92		V/V (Min)
C_{IN}	Input Capacitance	Case Shorted to Output	8			pF
R_{OUT}	Output Impedance	$V_{OUT} = \pm 10V$		4		Ω
V_O	Output Current Swing	$V_{IN} = \pm 10V$, $R_S < 100\text{ k}\Omega$	0.25	0.2		Amps (Min)
V_O	Output Voltage Swing	$R_L = 50\Omega$	11.4	± 10		V (Min)
V_O	Output Voltage Swing	$V_S = \pm 5.0V$, $R_L = 50\Omega$	± 2.7	± 2.5		V (Min)
I_S	Supply Current	$R_L = \infty$, $V_S = \pm 15V$	60	68		mA
I_S	Supply Current	$V_S = \pm 5.0V$	50			mA
P_D	Power Consumption	$R_L = \infty$, $V_S = \pm 15V$	1.8			W
P_D	Power Consumption	$V_S = \pm 5.0V$	0.5			W

DC Electrical Characteristics $V_S \pm 15V$, $R_S = R_L = 50\Omega$, $T_A = 25^\circ C$ unless otherwise specified (Note 1)

Symbol	Parameter	Conditions	LH4011C			Units (Max Unless Otherwise Noted)
			Typical	Tested Limit (Note 2)	Design Limit (Note 3)	
V_{OS}	Output Offset	$T_J = 25^\circ C$, $R_L = 50\Omega$ $R_S < 100\text{ k}\Omega$ (Note 4)	10	50		mV
$\Delta V_{OS}/\Delta T$	Aver. Temp. Coeff. of Output Offset Voltage	$R_S < 100\text{ k}\Omega$ $T_{MIN} < T_A < T_{MAX}$	300			$\mu V/^\circ C$
I_B	Input Bias Current	(Note 4)	10	30		nA
A_v	Voltage Gain	$V_{IN} = \pm 10V$, $R_L = 1\text{ k}\Omega$ $R_S < 100\text{ k}\Omega$	0.95	0.92		V/V (Min)
A_v	Voltage Gain	$V_{IN} = \pm 10V$, $R_L = 50\Omega$, $T_J = 25^\circ C$ $R_S < 100\text{ k}\Omega$	0.94	0.9		V/V (Min)
C_{IN}	Input Capacitance	Case Shorted to Output	8			pF
R_{OUT}	Output Impedance	$V_{OUT} = \pm 10V$		4		Ω
V_O	Output Current Swing	$V_{IN} = \pm 10V$, $R_S < 100\text{ k}\Omega$	0.25	0.2		Amps (Min)
V_O	Output Voltage Swing	$R_L = 50\Omega$	11.4	± 10		V (Min)
V_O	Output Voltage Swing	$V_S = \pm 5.0V$, $R_L = 50\Omega$	± 2.7	± 2.5		V (Min)
I_S	Supply Current	$R_L = \infty$, $V_S = \pm 15V$	60	68		mA
I_S	Supply Current	$V_S = \pm 5.0V$	50			mA
P_D	Power Consumption	$R_L = \infty$, $V_S = \pm 15V$	1.8			W
P_D	Power Consumption	$V_S = \pm 5.0V$	0.5			W

AC Electrical Characteristics $T_J = 25^\circ C$, $V_S = \pm 15V$, $R_S = 50\Omega$, $R_L = 50\Omega$

Symbol	Parameter	Conditions	LH4011C/LH4011			Units (Max Unless Otherwise Noted)
			Typical	Tested Limit (Note 2)	Design Limit (Note 3)	
SR	Slew Rate	$R_L = 50\Omega$, $V_{IN} = 20\text{ V}_{PP}$, 20% to 80%	5000			V/ μs
BW	Bandwidth	$V_{IN} = 1.0\text{ V}_{rms}$	160	140		MHz
PBW	Power Bandwidth	$\Delta V_{IN} = 20\text{ V}_{PP}$	80	60		MHz (Min)
	Phase Non-Linearity	BW = 1.0 MHz to 50 MHz	2			deg.
	Rise Time	$\Delta V_{IN} = 1\text{ V}_{PP}$	1.6			ns
	Propagation Delay	$\Delta V_{IN} = 1\text{ V}_{PP}$	1.9			ns
	Harmonic Distortion		<0.1			%

Note 1: Boldface limits are guaranteed over full temperature range. Operating ambient temperature range of LH4011C is $-25^\circ C$ to $+85^\circ C$, and LH4011 is $-55^\circ C$ to $125^\circ C$.

Note 2: Tested limits are guaranteed and 100% production tested.

Note 3: Design limits are guaranteed (but not production tested) over the indicated temperature range. These limits are not used to calculate outgoing quality level.

Note 4: Specification is at $25^\circ C$ junction temperature due to requirements of high speed automatic testing. Actual values at operating temperature will exceed value at $T_J = 25^\circ C$.

Typical Performance Characteristics

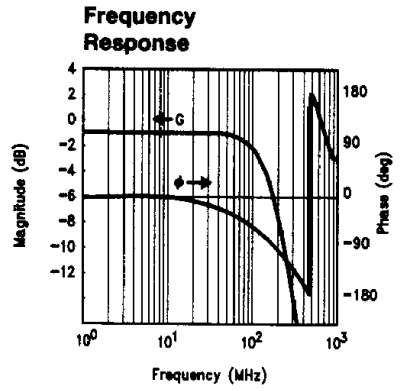
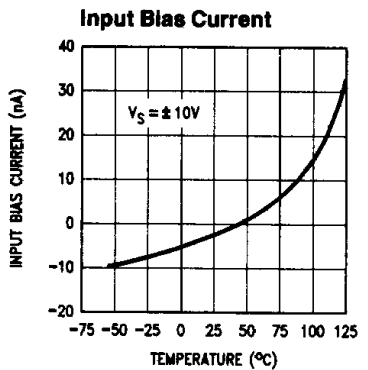
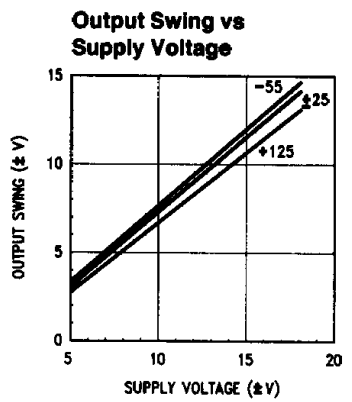
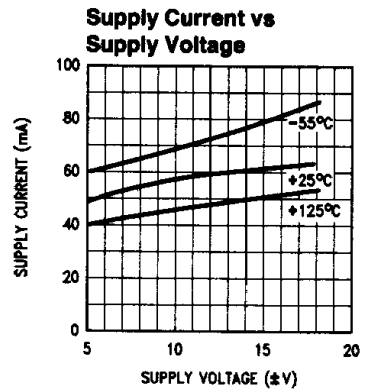
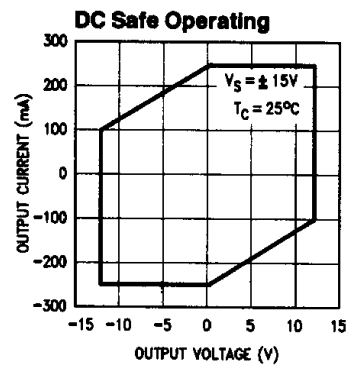
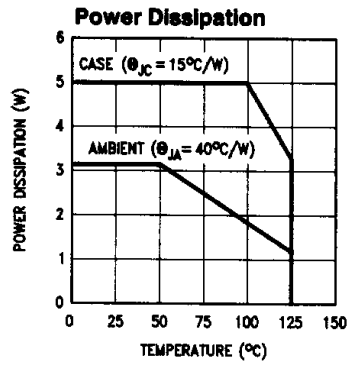

TL/K/9423-3

TL/K/9423-6

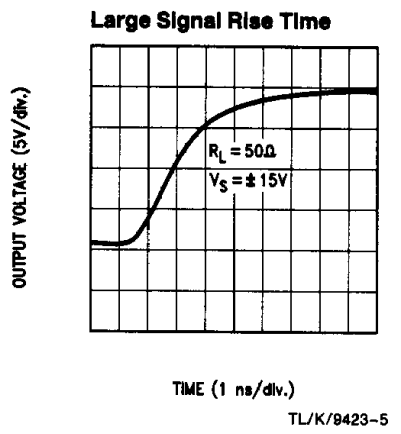
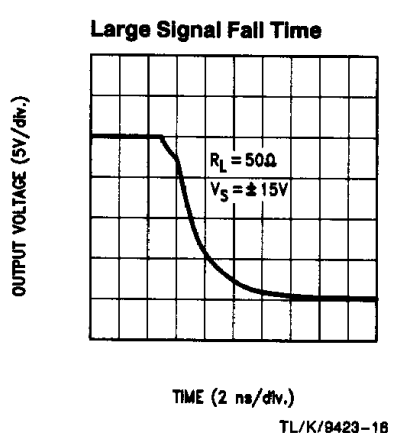
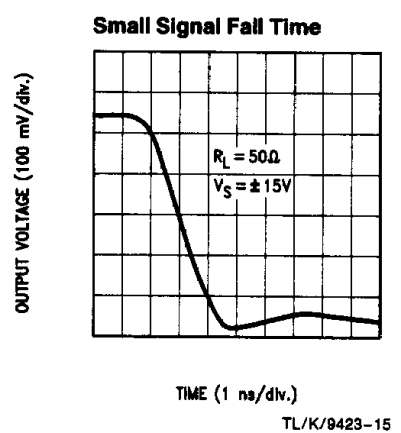
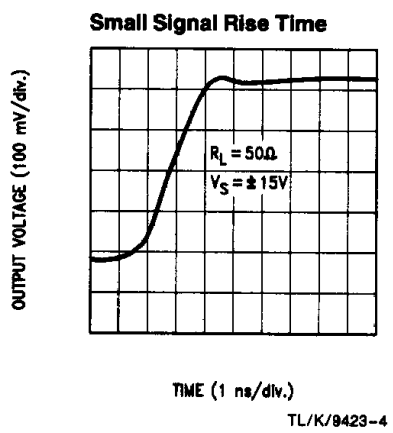

Schematic Diagram

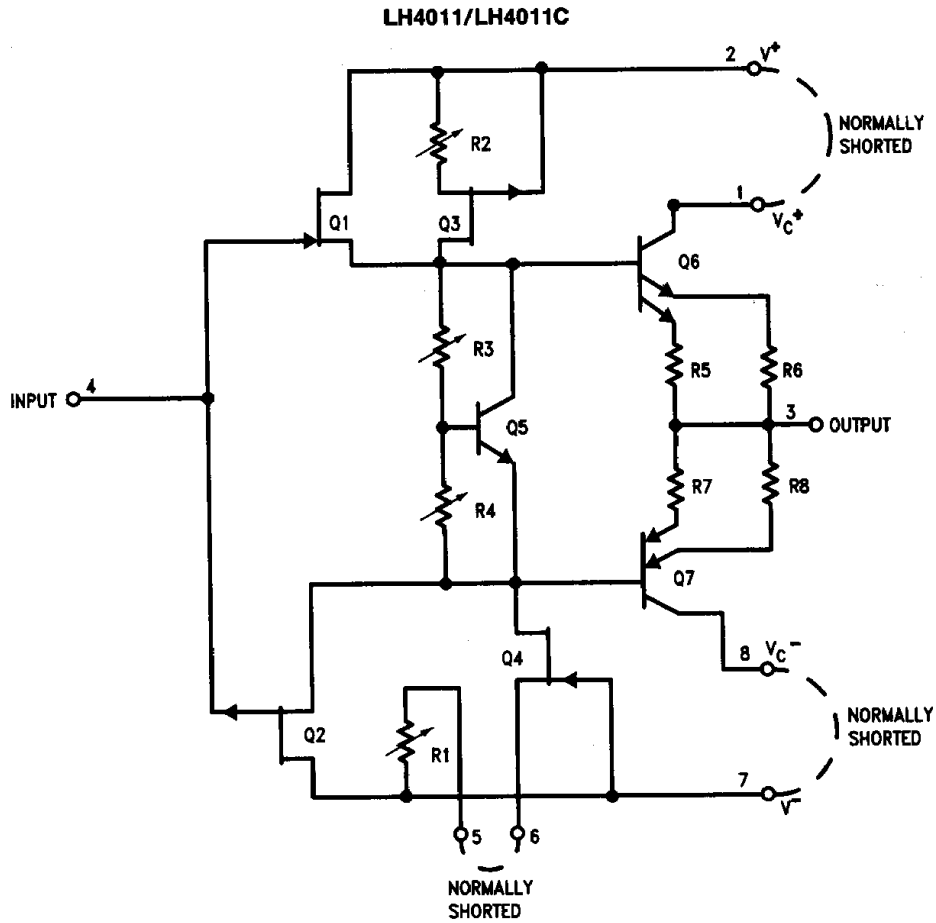

TL/K/9423-2

Bandwidth Test Circuit

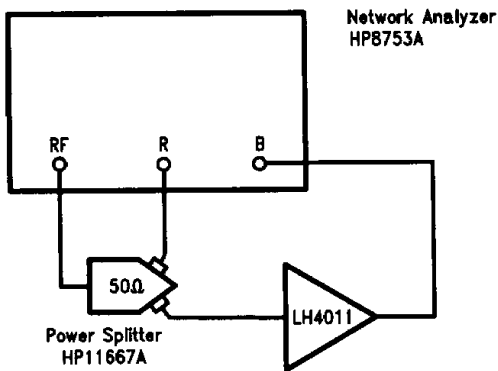

TL/K/9423-13

FIGURE 1. Bandwidth Test Circuit

Power Bandwidth Test Circuit

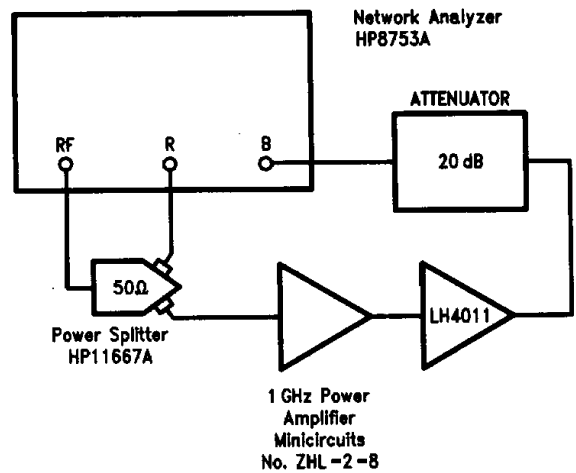

TL/K/9423-14

FIGURE 2. Power Bandwidth Test Circuit

Application Hints

Recommended Layout Precautions: RF/video printed circuit board layout rules should be followed when using the LH4011 since it will provide gain to frequencies over 160 MHz. Ground planes are recommended and power supplies should be decoupled at each device with low inductance capacitors. In addition, ground plane shielding may be extended to the metal case of the device since it is electrically isolated from internal circuitry. Alternatively, the case should be connected to the output to minimize input capacitance.

Short Circuit Protection: Short circuit protection may be added by inserting appropriate value resistors between V^+ and V_C^+ pins and V^- and V_C^- pins as illustrated in *Figure 4*. Resistor values may be predicted by:

$$R_{LIM} \approx \frac{V^+}{I_{SC}} = \frac{V^-}{I_{SC}}$$

The inclusion of limiting resistors in the collectors of the output transistors reduces output voltage swing. Decoupling V_C^+ and V_C^- pins with capacitors to ground will retain full output swing for transient pulses.

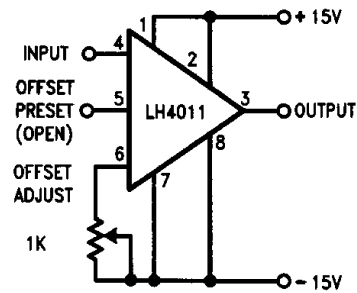

TL/K/9423-7

FIGURE 3. Offset Zero Adjust

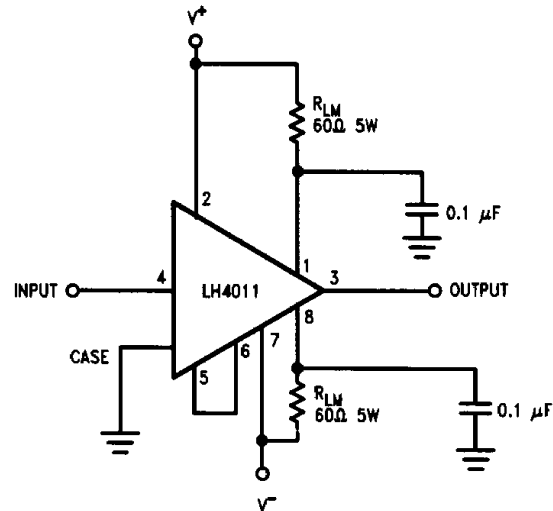

TL/K/9423-8

FIGURE 4. Using Resistor Current Limiting

Application Hints (Continued)

Capacitive Loading: The LH4011 is designed to drive capacitive loads such as coaxial cables in excess of several thousand picofarads without susceptibility to oscillation. However, peak current resulting from $(C \times dV/dt)$, should be limited below absolute maximum peak current ratings for the devices.

$$\left(\frac{\Delta V_{IN}}{\Delta t}\right) \times C_L \leq I_{OUT} \leq \pm 500 \text{ mA}$$

In addition, power dissipation resulting from driving capacitive loads plus standby power should be kept below the package power rating.

$$P_{diss \text{ pkg.}} \geq P_{DC} + P_{AC}$$

$$P_{diss \text{ pkg.}} \geq (V^+ - V^-) \times I_S + P_{AC}$$

$$P_{AC} = (V_{p-p})^2 \times f \times C_L$$

where V_{p-p} = Peak-to-peak output voltage swing

f = frequency

C_L = Load Capacitance

Operation Within an Op Amp Loop: The device may be used as a current booster or isolation buffer within a closed loop with op amps such as LH0032, LM6161, or LM118. An isolation resistor of 47Ω should be used between the op amp output and the input of LH4011. The wide bandwidth and high slew rate of the LH4011 assures that the loop has the characteristics of the op amp and that additional compensation is not required.

Hardware: In order to utilize the full drive capabilities of both devices, each should be mounted with a heat sink particularly for extended temperature operation. The cases of both are isolated from the circuit and may be connected to system chassis.

ATTENTION!

Power supply bypassing is necessary to prevent oscillation in all circuits. Low inductance ceramic disc capacitance with the shortest practical lead lengths must be connected from each supply lead (within $1/4$ to $1/2$ " of the device package) to a ground plane. Capacitors should be two $0.1 \mu\text{F}$ ceramic and one $4.7 \mu\text{F}$ solid tantalum capacitors in parallel on each supply lead.

Typical Applications

Coaxial Cable Driver

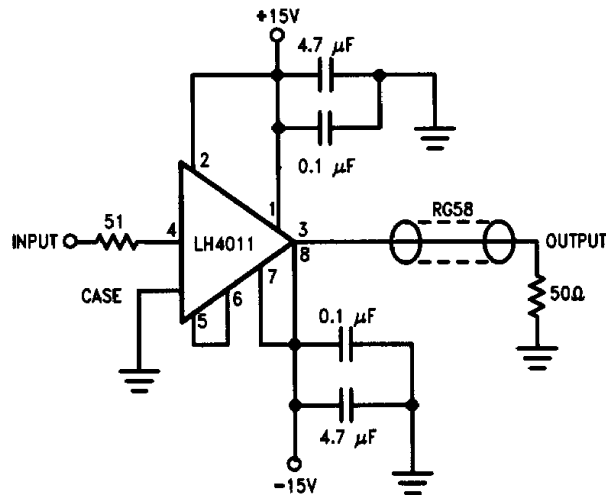

TL/K/9423-9

1W CW Final Amplifier

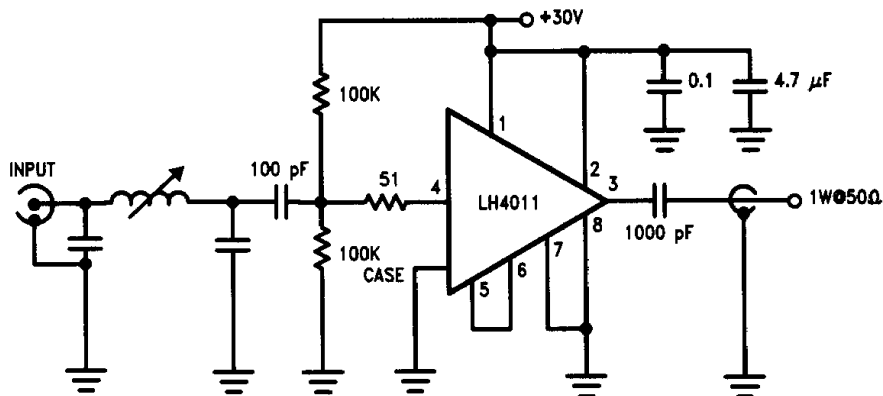

TL/K/9423-10

Typical Applications (Continued)

