

Wideband Video Buffer



LH4002A / LH4002 / LH4002C

FEATURES

- DC to 300 MHz Bandwidth with $V_S = \pm 5V$
- 3000 V/ μs Slew Rate into 50 Ω

APPLICATIONS

- Wideband Amplifier Buffer
- Wideband Line Driver
- Video
- Coaxial Cable Driver

GENERAL DESCRIPTION

The LH4002 family is a high speed voltage follower designed to drive video signals from DC up to 300MHz. At voltage supplies of $\pm 5V$, the LH4002 family will provide up to 80mA into 50 Ω at slew rates of 2000 V/ μs .

The LH4002 family is intended to fulfill a wide range of high speed applications including video distribution, impedance transformation, and load isolation. It is also suitable for use in current booster applications within an op amp loop. This allows the output current capability of existing op amps to be increased.

ORDERING INFORMATION

| Part | Package | Temperature Range |
|----------|----------------------------|-------------------|
| LH4002AH | HO8A (TO5-8 Lead) | -55°C to +125°C |
| LH4002H | HO8A (TO5-8 Lead) | -55°C to +125°C |
| LH4002CH | HO8A (TO5-8 Lead) | -40°C to +85°C |
| LH4002AN | N10A (Plastic Dip-10 Lead) | -40°C to +85°C |
| LH4002N | N10A (Plastic Dip-10 Lead) | -40°C to +85°C |
| LH4002CN | N10A (Plastic Dip-10 Lead) | -40°C to +85°C |

CONNECTION DIAGRAMS

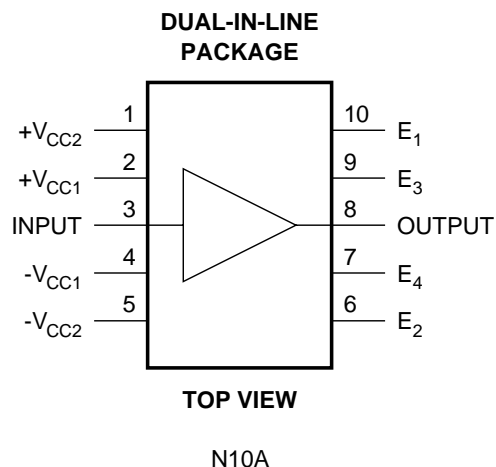
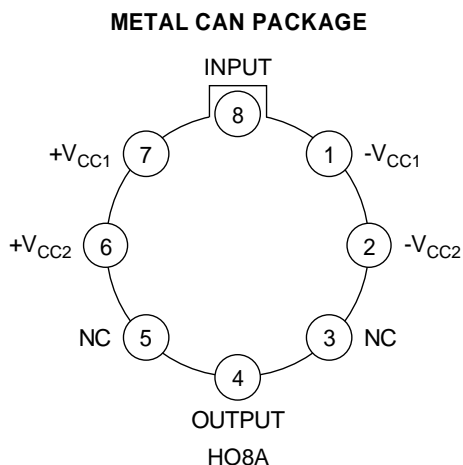

ABSOLUTE MAXIMUM RATINGS (Note 1)

| | | | |
|-------------------------------------|-----------------------------------|---|------------------|
| Supply Voltage | ± 10 | ESD Tolerance (Note 3) | $\pm 2000V$ |
| Input Voltage | $\pm V_{supply}$ | Thermal Resistance (θ_{JA}) (Note 6) | |
| Storage Temperature Range | $-65^{\circ}C$ to $+150^{\circ}C$ | H Package | $125^{\circ}C/W$ |
| Lead Temperature | | N Package | $50^{\circ}C/W$ |
| (Soldering 10 seconds) | $260^{\circ}C$ | Maximum Junction Temperature | $150^{\circ}C$ |
| Power Dissipation | (Note 4) | | |

DC ELECTRICAL CHARACTERISTICS

The following specifications apply for Supply Voltage = $\pm 5V$, $V_{CM} = 0$, $R_L \geq 100K\Omega$ and $R_S = 50\Omega$ unless otherwise noted.

Boldface limits apply for $T_A = T_J = T_{MIN}$ to T_{MAX} ; all other limits $T_A = T_J = 25^{\circ}C$.

| SYMBOL | CHARACTERISTICS | TYP | LH4002A | LH4002 | LH4002C | UNITS | CONDITIONS |
|-----------|--------------------|------|---------------------|---------------------|---------------------|--------------|--|
| | | | Limit (Note 5) | Limit (Note 5) | Limit (Note 5) | | |
| A_{V1} | Voltage Gain 1 | 0.99 | 0.96 0.95 | 0.95 0.95 | 0.95 0.95 | V/V Min | $R_L = 1K, V_{IN} = \pm 2V, R_S = 10K$ |
| A_{V2} | Voltage Gain 2 | 0.92 | 0.89 | 0.88 | 0.87 | | $R_L = 50\Omega, V_{IN} = \pm 3V$ |
| A_{V3} | Voltage Gain 3 | 0.92 | 0.89 | 0.87 | 0.87 | | $R_L = 50\Omega, V_{IN} = \pm 2V$ |
| V_{OS} | Offset Voltage | 10 | 15 25 | 25 35 | 30 40 | mV Max | $R_L = 50\Omega, R_S = 150\Omega$ |
| I_B | Input Bias Current | 1 | 10 20 | 15 30 | 20 40 | μA Max | $R_L = 50\Omega, R_S = 1K\Omega$ |
| R_{IN} | Input Resistance | 0.3 | | | | M Ω | $R_S = 10K, R_L = 50\Omega$ |
| C_{IN} | Input Capacitance | 3.5 | | | | pF | |
| R_O | Output Resistance | 3 | 10 10 | 10 10 | 10 10 | Ω Max | $R_S = 10K, R_L = 50\Omega$ |
| I_{S1} | Supply Current 1 | 20 | 30 35 | 30 35 | 35 35 | mA Max | $R_S = 10K, V_{IN} = 0V, R_L = 1K$ |
| V_{O1} | Output Swing 1 | 2.4 | 2.2 2.2 | 2.2 2.2 | 2.2 2.2 | $\pm V$ Min | $R_S = 150\Omega, V_{IN} = \pm 2.5V, R_L = 50\Omega$ |
| V_{O2} | Output Swing 2 | 2.2 | 2 | 2 | 2 | | $R_S = 150\Omega, V_{IN} = \pm 2.5V, R_L = 1K$ |
| V_{O3} | Output Swing 3 | 3.6 | 3.0 | 3.0 | 3.0 | V_{PP} Min | $R_S = 150\Omega, V_{IN} = \pm 4.5V, R_L = 50\Omega$ |
| I_{OUT} | Output Current | 80 | 60 | 60 | 60 | mA | $V_{IN} = 4V$ |

AC ELECTRICAL CHARACTERISTICS

The following specifications apply for Supply Voltage = $\pm 5V$, $V_{CM} = 0$, $R_L \geq 100K\Omega$ and $R_S = 50\Omega$ unless otherwise noted.

Boldface limits apply for $T_A = T_J = T_{MIN}$ to T_{MAX} ; all other limits $T_A = T_J = 25^\circ C$.

| SYMBOL | CHARACTERISTICS | TYP | LH4002A | LH4002 | LH4002C | UNITS | CONDITIONS |
|---------------------------------|------------------------|------|----------------|----------------|----------------|------------|--|
| | | | Limit (Note 5) | Limit (Note 5) | Limit (Note 5) | | |
| SR ₁ | Slew Rate 1 | 3000 | 2750 | 2500 | 2500 | V/ μ s | $V_{IN} = \pm 2V$, $R_L = 50\Omega$ (Note 2) |
| SR ₂ | Slew Rate 2 | 2000 | 1750 | 1600 | 1500 | | $V_{IN} = \pm 4V$, $R_L = 50\Omega$ (Note 2) |
| SS _{BW} | Small Signal Bandwidth | 300 | 250 | 220 | 200 | MHz | $R_L = 50\Omega$, $V_{OUT} = 100mV_{P-P}$ |
| LS _{BW} | Large Signal Bandwidth | 140 | 100 | 90 | 80 | | $R_L = 50\Omega$, $V_{OUT} = 2V_{P-P}$ |
| P _{BW} | Power Bandwidth | 130 | 100 | 90 | 80 | | $R_L = 50\Omega$, $V_{OUT} = 4V_{P-P}$ |
| t _r , t _f | Rise Time Fall Time | 1.2 | 1.5 | 1.7 | 1.8 | ns | $R_L = 50\Omega$, $C_L \leq 10pF$ $V_O = 100mV_{PP}$ |
| t _{pd} | Propagation Delay Time | 2.0 | | | | ns | $R_L = 50\Omega$, $C_L \leq 10pF$ $V_O = 100mV_{PP}$ |
| O _S | Overshoot | 10 | | | | % | $R_L = 50\Omega$, $C_L \leq 10pF$ $V_O = 100mV_{PP}$ |

Note 1: Absolute Maximum Ratings indicate limits beyond which damage to the device may occur. DC and AC electrical specifications do not apply when operating the device beyond its rated operating conditions.

Note 2: Slew rate is measured with 50Ω source impedance at $25^\circ C$. For accurate measurements, the input slew rate should be at least $5000V/\mu s$.

Note 3: The test circuit consists of the human body model of $120pF$ in series with 1500Ω .

Note 4: The maximum power dissipation is a function of $T_{J(max)}$, θ_{JA} and T_A . The maximum allowable power dissipation at any ambient temperature is $P_D = (T_{J(max)} - T_A)/\theta_{JA}$.

Note 5: Limits are guaranteed by testing, correlation or periodic characterization.

Note 6: For N package, θ_{JA} is measured by soldering the unit directly on a printed circuit board and V pins are connected to 2 square inches of 2 oz copper.

TYPICAL PERFORMANCE CHARACTERISTICS

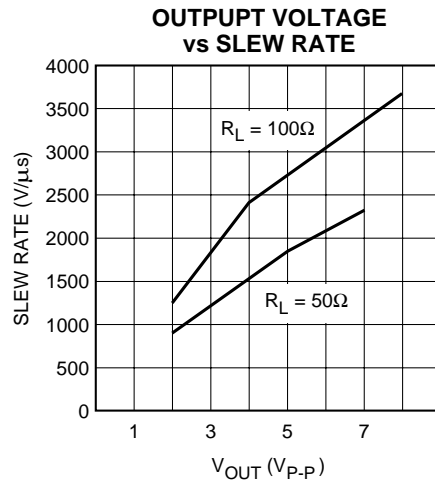
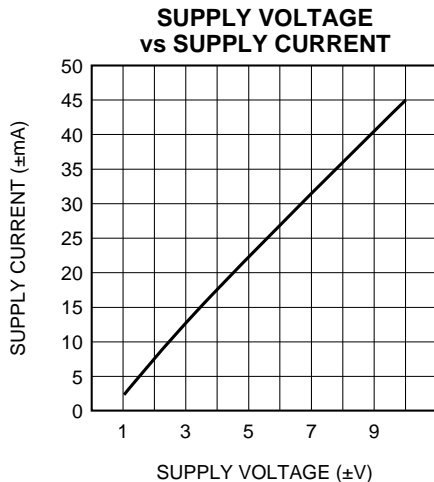
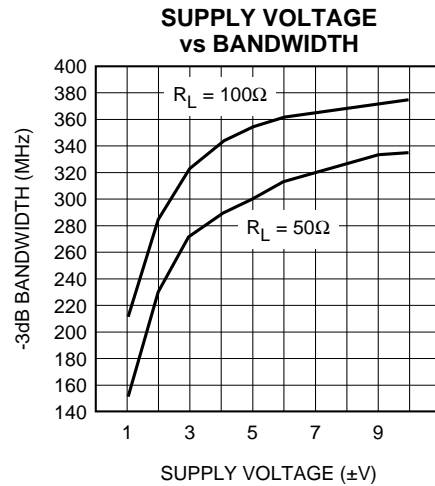
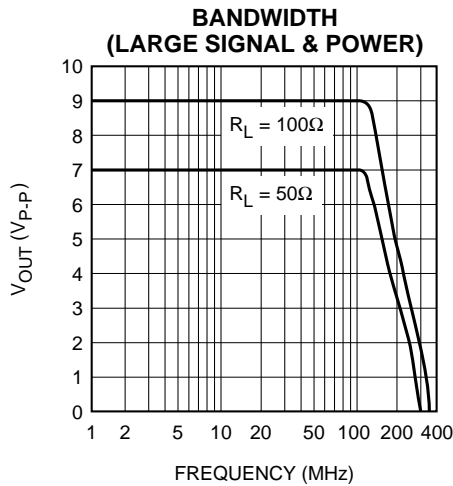
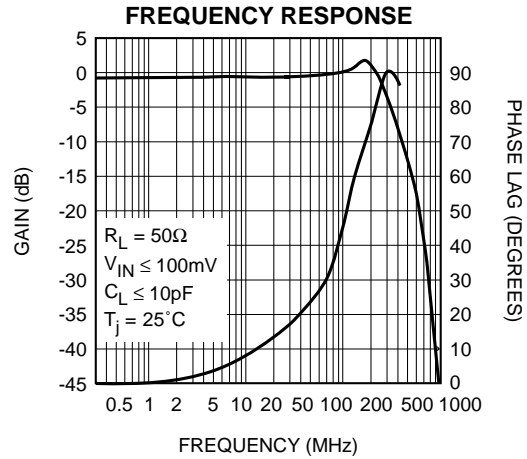
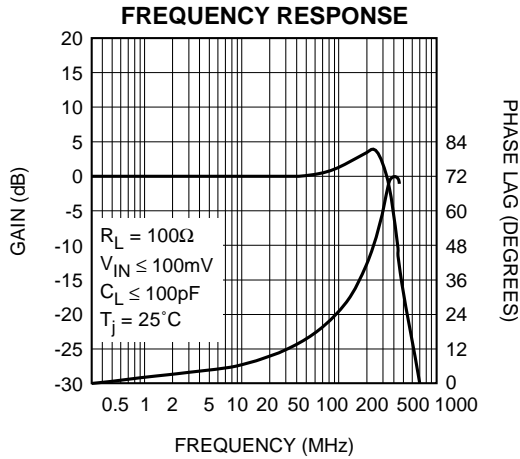

Wideband Unity Gain Amplifier

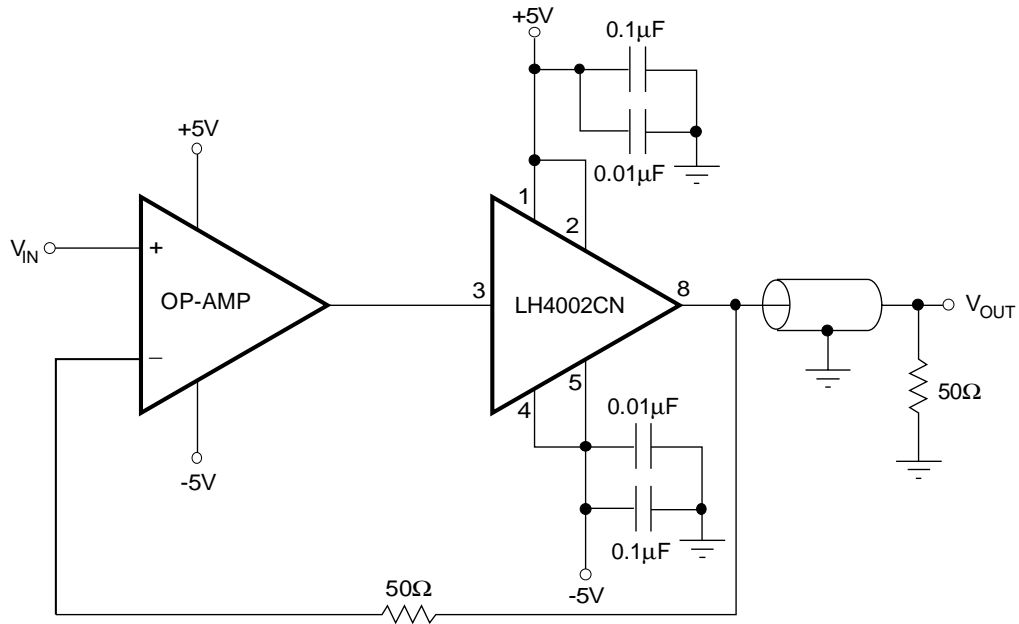

Short Circuit Protection

