



KF00 SERIES

VERY LOW DROP VOLTAGE REGULATORS WITH INHIBIT

- VERY LOW DROPOUT VOLTAGE (0.4V)
- VERY LOW QUIESCENT CURRENT (TYP. 50 μ A IN OFF MODE, 500 μ A IN ON MODE)
- OUTPUT CURRENT UP TO 500 mA
- LOGIC-CONTROLLED ELECTRONIC SHUTDOWN
- OUTPUT VOLTAGES OF 1.25; 1.5; 2.5; 2.7; 3; 3.3; 3.5; 4; 4.5; 4.7; 5; 5.2; 5.5; 6; 8; 8.5; 12V
- INTERNAL CURRENT AND THERMAL LIMIT
- ONLY 2.2 μ F FOR STABILITY
- AVAILABLE IN \pm 2% ACCURACY AT 25 $^{\circ}$ C
- SUPPLY VOLTAGE REJECTION: 70 db (TYP.)
- TEMPERATURE RANGE: -40 TO 125 $^{\circ}$ C

DESCRIPTION

The KF00 series are very Low Drop regulators available in SO-8 package and in a wide range of output voltages.

The very Low Drop voltage (0.4V) and the very low quiescent current make them particularly

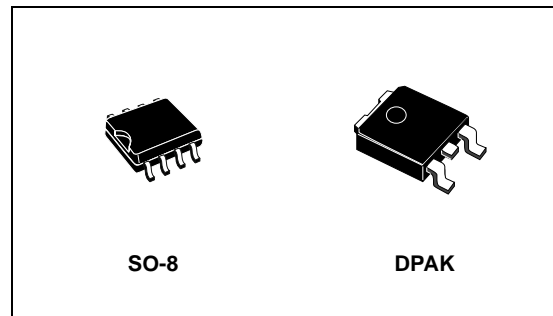

suitable for Low Noise, Low Power applications and specially in battery powered systems.

A Shutdown Logic Control function is available (pin 5, TTL compatible). This means that when the device is used as a local regulator, it is possible to put a part of the board in standby, decreasing the total power consumption. It requires only a 2.2 μ F capacitor for stability allowing space and cost saving.

SCHEMATIC DIAGRAM

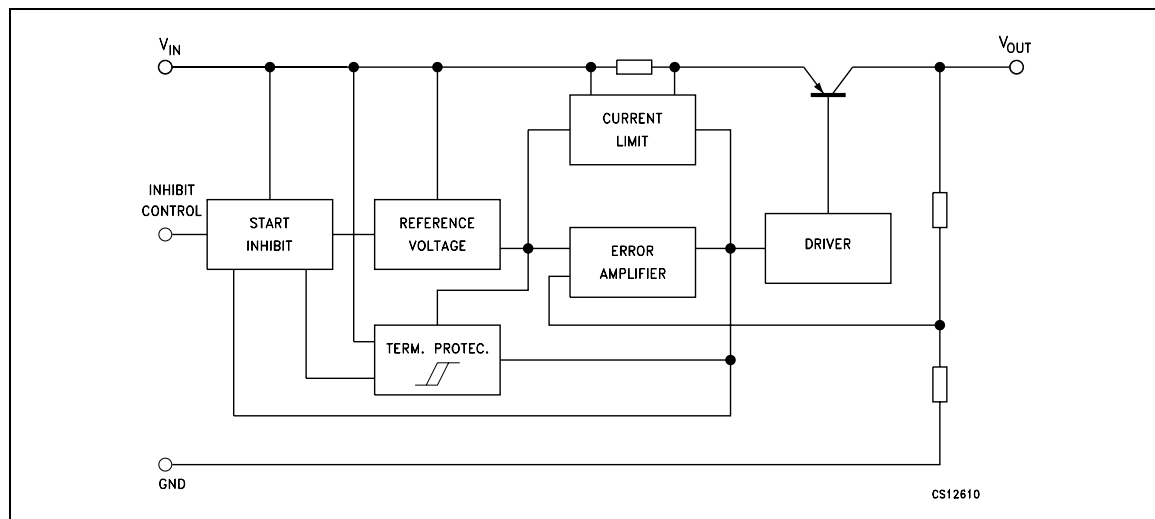

KF00

ABSOLUTE MAXIMUM RATINGS

Symbol	Parameter	Value	Unit
V_I	DC Input Voltage	-0.5 to 20	V
I_O	Output Current	Internally Limited	
P_{tot}	Power Dissipation	Internally Limited	
T_{stg}	Storage Temperature Range	-40 to 150	°C
T_{op}	Operating Junction Temperature Range	-40 to 125	°C

Absolute Maximum Ratings are those values beyond which damage to the device may occur. Functional operation under these condition is not implied.

THERMAL DATA

Symbol	Parameter	DPAK	SO-8	Unit
$R_{thj-case}$	Thermal Resistance Junction-case	8	20	°C/W

CONNECTION DIAGRAM (top view)

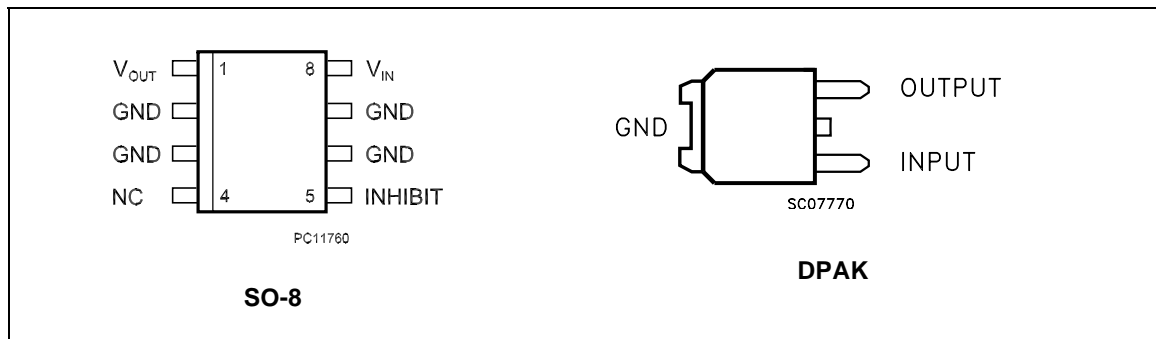

ORDERING CODES

TYPE	SO-8(#)	DPAK(#)	OUTPUT VOLTAGE
KF12(*)	KF12BD	KF12BDT	1.25 V
KF15	KF15BD	KF15BDT	1.5 V
KF25	KF25BD	KF25BDT	2.5 V
KF27	KF27BD	KF27BDT	2.7 V
KF30	KF30BD	KF30BDT	3 V
KF33	KF33BD	KF33BDT	3.3 V
KF35	KF35BD	KF35BDT	3.5 V
KF40	KF40BD	KF40BDT	4 V
KF45(*)	KF45BD	KF45BDT	4.5 V
KF47	KF47BD	KF47BDT	4.75 V
KF50	KF50BD	KF50BDT	5 V
KF52	KF52BD	KF52BDT	5.2 V
KF55(*)	KF55BD	KF55BDT	5.5 V
KF60	KF60BD	KF60BDT	6 V
KF80	KF80BD	KF80BDT	8 V
KF85	KF85BD	KF85BDT	8.5 V
KF120	KF120BD	KF120BDT	12 V

(*) Available on request.

(#) Available in Tape & Reel with the suffix "-TR".

TEST CIRCUITS

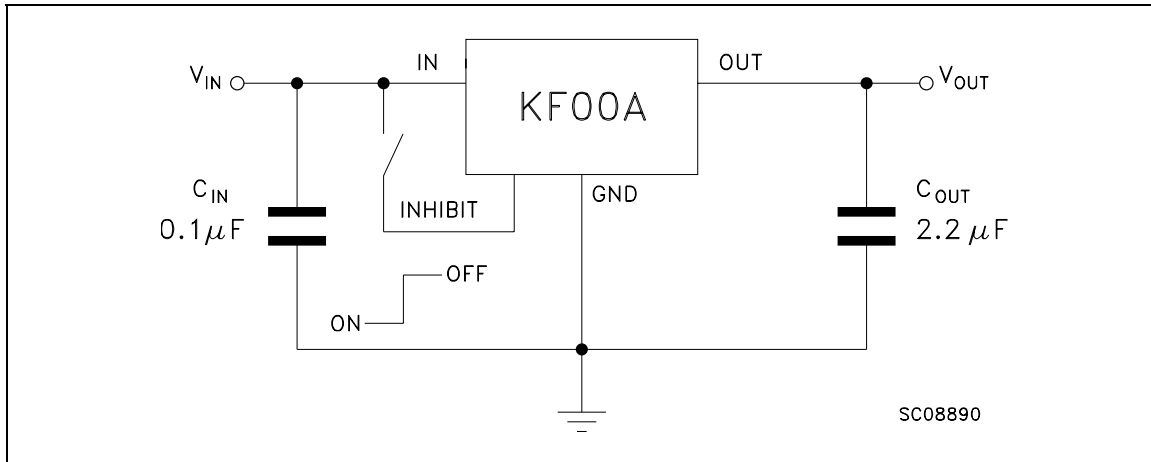

ELECTRICAL CHARACTERISTICS FOR KF12 (refer to the test circuits, $T_j = 25^\circ\text{C}$, $C_I = 0.1\ \mu\text{F}$, $C_O = 2.2\ \mu\text{F}$ unless otherwise specified.)

Symbol	Parameter	Test Conditions	Min.	Typ.	Max.	Unit
V_O	Output Voltage	$I_O = 50\ \text{mA}$, $V_I = 3.3\ \text{V}$	1.225	1.25	1.275	V
		$I_O = 50\ \text{mA}$, $V_I = 3.3\ \text{V}$, $T_a = -25\ \text{to}\ 85^\circ\text{C}$	1.2		1.3	
V_I	Operating Input Voltage	$I_O = 500\ \text{mA}$	2.5		20	V
I_O	Output Current Limit			1		A
ΔV_O	Line Regulation	$V_I = 2.5\ \text{to}\ 20\ \text{V}$, $I_O = 5\ \text{mA}$		2	12	mV
ΔV_O	Load Regulation	$V_I = 2.8\ \text{V}$, $I_O = 5\ \text{to}\ 500\ \text{mA}$		2	50	mV
I_d	Quiescent Current	$V_I = 2.5\ \text{to}\ 20\ \text{V}$, $I_O = 0\ \text{mA}$	(ON MODE)	0.5	1	mA
		$V_I = 2.6\ \text{to}\ 20\ \text{V}$, $I_O = 500\ \text{mA}$			12	
		$V_I = 6\ \text{V}$	(OFF MODE)	50	100	μA
SVR	Supply Voltage Rejection	$I_O = 5\ \text{mA}$ $V_I = 3.5 \pm 1\ \text{V}$	$f = 120\ \text{Hz}$	82		dB
			$f = 1\ \text{KHz}$	77		
			$f = 10\ \text{KHz}$	60		
eN	Output Noise Voltage	$B = 10\ \text{Hz to}\ 100\ \text{KHz}$		50		μV
V_d	Dropout Voltage	$I_O = 200\ \text{mA}$		1.25		V
V_{IL}	Control Input Logic Low	$T_a = -40\ \text{to}\ 125^\circ\text{C}$			0.8	V
V_{IH}	Control Input Logic High	$T_a = -40\ \text{to}\ 125^\circ\text{C}$	2			V
I_I	Control Input Current	$V_I = 6\ \text{V}$, $V_C = 6\ \text{V}$		10		μA
C_O	Output Bypass Capacitance	$\text{ESR} = 0.1\ \text{to}\ 10\ \Omega$, $I_O = 0\ \text{to}\ 500\ \text{mA}$	2	10		μF

KF00

ELECTRICAL CHARACTERISTICS FOR KF15 (refer to the test circuits, $T_j = 25^\circ\text{C}$, $C_1 = 0.1\ \mu\text{F}$, $C_O = 2.2\ \mu\text{F}$ unless otherwise specified.)

Symbol	Parameter	Test Conditions	Min.	Typ.	Max.	Unit
V_O	Output Voltage	$I_O = 50\ \text{mA}$, $V_I = 3.5\ \text{V}$	1.47	1.5	1.53	V
		$I_O = 50\ \text{mA}$, $V_I = 3.5\ \text{V}$, $T_a = -25\ \text{to}\ 85^\circ\text{C}$	1.44		1.56	
V_I	Operating Input Voltage	$I_O = 500\ \text{mA}$	2.5		20	V
I_O	Output Current Limit			1		A
ΔV_O	Line Regulation	$V_I = 2.5\ \text{to}\ 20\ \text{V}$, $I_O = 5\ \text{mA}$		2	12	mV
ΔV_O	Load Regulation	$V_I = 2.8\ \text{V}$, $I_O = 5\ \text{to}\ 500\ \text{mA}$		2	50	mV
I_d	Quiescent Current	$V_I = 2.5\ \text{to}\ 20\ \text{V}$, $I_O = 0\ \text{mA}$	(ON MODE)	0.5	1	mA
		$V_I = 2.8\ \text{to}\ 20\ \text{V}$, $I_O = 500\ \text{mA}$				
		$V_I = 6\ \text{V}$	(OFF MODE)	50	100	μA
SVR	Supply Voltage Rejection	$I_O = 5\ \text{mA}$ $V_I = 3.5 \pm 1\ \text{V}$	$f = 120\ \text{Hz}$	82		dB
			$f = 1\ \text{KHz}$	77		
			$f = 10\ \text{KHz}$	60		
eN	Output Noise Voltage	$B = 10\ \text{Hz to}\ 100\ \text{KHz}$		50		μV
V_d	Dropout Voltage	$I_O = 200\ \text{mA}$		1		V
V_{IL}	Control Input Logic Low	$T_a = -40\ \text{to}\ 125^\circ\text{C}$			0.8	V
V_{IH}	Control Input Logic High	$T_a = -40\ \text{to}\ 125^\circ\text{C}$	2			V
I_I	Control Input Current	$V_I = 6\ \text{V}$, $V_C = 6\ \text{V}$		10		μA
C_O	Output Bypass Capacitance	$\text{ESR} = 0.1\ \text{to}\ 10\ \Omega$, $I_O = 0\ \text{to}\ 500\ \text{mA}$	2	10		μF

ELECTRICAL CHARACTERISTICS FOR KF25 (refer to the test circuits, $T_j = 25^\circ\text{C}$, $C_1 = 0.1\ \mu\text{F}$, $C_O = 2.2\ \mu\text{F}$ unless otherwise specified.)

Symbol	Parameter	Test Conditions	Min.	Typ.	Max.	Unit
V_O	Output Voltage	$I_O = 50\ \text{mA}$, $V_I = 4.5\ \text{V}$	2.45	2.5	2.55	V
		$I_O = 50\ \text{mA}$, $V_I = 4.5\ \text{V}$, $T_a = -25\ \text{to}\ 85^\circ\text{C}$	2.4		2.6	
V_I	Operating Input Voltage	$I_O = 500\ \text{mA}$			20	V
I_O	Output Current Limit			1		A
ΔV_O	Line Regulation	$V_I = 3.5\ \text{to}\ 20\ \text{V}$, $I_O = 5\ \text{mA}$		2	12	mV
ΔV_O	Load Regulation	$V_I = 3.8\ \text{V}$, $I_O = 5\ \text{to}\ 500\ \text{mA}$		2	50	mV
I_d	Quiescent Current	$V_I = 3.5\ \text{to}\ 20\ \text{V}$, $I_O = 0\ \text{mA}$	(ON MODE)	0.5	1	mA
		$V_I = 3.8\ \text{to}\ 20\ \text{V}$, $I_O = 500\ \text{mA}$				
		$V_I = 6\ \text{V}$	(OFF MODE)	50	100	μA
SVR	Supply Voltage Rejection	$I_O = 5\ \text{mA}$ $V_I = 4.5 \pm 1\ \text{V}$	$f = 120\ \text{Hz}$	82		dB
			$f = 1\ \text{KHz}$	77		
			$f = 10\ \text{KHz}$	60		
eN	Output Noise Voltage	$B = 10\ \text{Hz to}\ 100\ \text{KHz}$		50		μV
V_d	Dropout Voltage	$I_O = 200\ \text{mA}$		0.2	0.35	V
		$I_O = 500\ \text{mA}$		0.4	0.7	
V_{IL}	Control Input Logic Low	$T_a = -40\ \text{to}\ 125^\circ\text{C}$			0.8	V
V_{IH}	Control Input Logic High	$T_a = -40\ \text{to}\ 125^\circ\text{C}$	2			V
I_I	Control Input Current	$V_I = 6\ \text{V}$, $V_C = 6\ \text{V}$		10		μA
C_O	Output Bypass Capacitance	$\text{ESR} = 0.1\ \text{to}\ 10\ \Omega$, $I_O = 0\ \text{to}\ 500\ \text{mA}$	2	10		μF

ELECTRICAL CHARACTERISTICS FOR KF27 (refer to the test circuits, $T_j = 25^\circ\text{C}$, $C_I = 0.1\ \mu\text{F}$, $C_O = 2.2\ \mu\text{F}$ unless otherwise specified.)

Symbol	Parameter	Test Conditions	Min.	Typ.	Max.	Unit
V_O	Output Voltage	$I_O = 50\ \text{mA}$, $V_I = 4.7\ \text{V}$	2.646	2.7	2.754	V
		$I_O = 50\ \text{mA}$, $V_I = 4.7\ \text{V}$, $T_a = -25\ \text{to}\ 85^\circ\text{C}$	2.592		2.808	
V_I	Operating Input Voltage	$I_O = 500\ \text{mA}$			20	V
I_O	Output Current Limit			1		A
ΔV_O	Line Regulation	$V_I = 3.7\ \text{to}\ 20\ \text{V}$, $I_O = 5\ \text{mA}$		2	12	mV
ΔV_O	Load Regulation	$V_I = 4\ \text{V}$, $I_O = 5\ \text{to}\ 500\ \text{mA}$		2	50	mV
I_d	Quiescent Current	$V_I = 3.7\ \text{to}\ 20\ \text{V}$, $I_O = 0\ \text{mA}$ (ON MODE)		0.5	1	mA
		$V_I = 4\ \text{to}\ 20\ \text{V}$, $I_O = 500\ \text{mA}$			12	
		$V_I = 6\ \text{V}$ (OFF MODE)		50	100	μA
SVR	Supply Voltage Rejection	$I_O = 5\ \text{mA}$ $V_I = 4.7 \pm 1\ \text{V}$	$f = 120\ \text{Hz}$	82		dB
			$f = 1\ \text{KHz}$	77		
			$f = 10\ \text{KHz}$	60		
eN	Output Noise Voltage	$B = 10\ \text{Hz to}\ 100\ \text{KHz}$		50		μV
V_d	Dropout Voltage	$I_O = 200\ \text{mA}$		0.2	0.35	V
		$I_O = 500\ \text{mA}$		0.4	0.7	
V_{IL}	Control Input Logic Low	$T_a = -40\ \text{to}\ 125^\circ\text{C}$			0.8	V
V_{IH}	Control Input Logic High	$T_a = -40\ \text{to}\ 125^\circ\text{C}$	2			V
I_I	Control Input Current	$V_I = 6\ \text{V}$, $V_C = 6\ \text{V}$		10		μA
C_O	Output Bypass Capacitance	$\text{ESR} = 0.1\ \text{to}\ 10\ \Omega$, $I_O = 0\ \text{to}\ 500\ \text{mA}$	2	10		μF

ELECTRICAL CHARACTERISTICS FOR KF30 (refer to the test circuits, $T_j = 25^\circ\text{C}$, $C_I = 0.1\ \mu\text{F}$, $C_O = 2.2\ \mu\text{F}$ unless otherwise specified.)

Symbol	Parameter	Test Conditions	Min.	Typ.	Max.	Unit
V_O	Output Voltage	$I_O = 50\ \text{mA}$, $V_I = 5\ \text{V}$	2.94	3	3.06	V
		$I_O = 50\ \text{mA}$, $V_I = 5\ \text{V}$, $T_a = -25\ \text{to}\ 85^\circ\text{C}$	2.88		3.12	
V_I	Operating Input Voltage	$I_O = 500\ \text{mA}$			20	V
I_O	Output Current Limit			1		A
ΔV_O	Line Regulation	$V_I = 4\ \text{to}\ 20\ \text{V}$, $I_O = 5\ \text{mA}$		2	12	mV
ΔV_O	Load Regulation	$V_I = 4.3\ \text{V}$, $I_O = 5\ \text{to}\ 500\ \text{mA}$		2	50	mV
I_d	Quiescent Current	$V_I = 4\ \text{to}\ 20\ \text{V}$, $I_O = 0\ \text{mA}$ (ON MODE)		0.5	1	mA
		$V_I = 4.3\ \text{to}\ 20\ \text{V}$, $I_O = 500\ \text{mA}$			12	
		$V_I = 6\ \text{V}$ (OFF MODE)		50	100	μA
SVR	Supply Voltage Rejection	$I_O = 5\ \text{mA}$ $V_I = 5 \pm 1\ \text{V}$	$f = 120\ \text{Hz}$	81		dB
			$f = 1\ \text{KHz}$	76		
			$f = 10\ \text{KHz}$	60		
eN	Output Noise Voltage	$B = 10\ \text{Hz to}\ 100\ \text{KHz}$		50		μV
V_d	Dropout Voltage	$I_O = 200\ \text{mA}$		0.2	0.35	V
		$I_O = 500\ \text{mA}$		0.4	0.7	
V_{IL}	Control Input Logic Low	$T_a = -40\ \text{to}\ 125^\circ\text{C}$			0.8	V
V_{IH}	Control Input Logic High	$T_a = -40\ \text{to}\ 125^\circ\text{C}$	2			V
I_I	Control Input Current	$V_I = 6\ \text{V}$, $V_C = 6\ \text{V}$		10		μA
C_O	Output Bypass Capacitance	$\text{ESR} = 0.1\ \text{to}\ 10\ \Omega$, $I_O = 0\ \text{to}\ 500\ \text{mA}$	2	10		μF

KF00

ELECTRICAL CHARACTERISTICS FOR KF33 (refer to the test circuits, $T_j = 25^\circ\text{C}$, $C_I = 0.1\ \mu\text{F}$, $C_O = 2.2\ \mu\text{F}$ unless otherwise specified.)

Symbol	Parameter	Test Conditions	Min.	Typ.	Max.	Unit
V_O	Output Voltage	$I_O = 50\ \text{mA}$, $V_I = 5.3\ \text{V}$	3.234	3.3	3.366	V
		$I_O = 50\ \text{mA}$, $V_I = 5.3\ \text{V}$, $T_a = -25\ \text{to}\ 85^\circ\text{C}$	3.168		3.432	
V_I	Operating Input Voltage	$I_O = 500\ \text{mA}$			20	V
I_O	Output Current Limit			1		A
ΔV_O	Line Regulation	$V_I = 4.3\ \text{to}\ 20\ \text{V}$, $I_O = 5\ \text{mA}$		2	12	mV
ΔV_O	Load Regulation	$V_I = 4.6\ \text{V}$, $I_O = 5\ \text{to}\ 500\ \text{mA}$		2	50	mV
I_d	Quiescent Current	$V_I = 4.3\ \text{to}\ 20\ \text{V}$, $I_O = 0\ \text{mA}$	(ON MODE)	0.5	1	mA
		$V_I = 4.6\ \text{to}\ 20\ \text{V}$, $I_O = 500\ \text{mA}$			12	
		$V_I = 6\ \text{V}$	(OFF MODE)	50	100	μA
SVR	Supply Voltage Rejection	$I_O = 5\ \text{mA}$ $V_I = 5.3 \pm 1\ \text{V}$	$f = 120\ \text{Hz}$	80		dB
			$f = 1\ \text{KHz}$	75		
			$f = 10\ \text{KHz}$	60		
eN	Output Noise Voltage	$B = 10\ \text{Hz to}\ 100\ \text{KHz}$		50		μV
V_d	Dropout Voltage	$I_O = 200\ \text{mA}$		0.2	0.35	V
		$I_O = 500\ \text{mA}$		0.4	0.7	
V_{IL}	Control Input Logic Low	$T_a = -40\ \text{to}\ 125^\circ\text{C}$			0.8	V
V_{IH}	Control Input Logic High	$T_a = -40\ \text{to}\ 125^\circ\text{C}$	2			V
I_I	Control Input Current	$V_I = 6\ \text{V}$, $V_C = 6\ \text{V}$		10		μA
C_O	Output Bypass Capacitance	$\text{ESR} = 0.1\ \text{to}\ 10\ \Omega$, $I_O = 0\ \text{to}\ 500\ \text{mA}$	2	10		μF

ELECTRICAL CHARACTERISTICS FOR KF35 (refer to the test circuits, $T_j = 25^\circ\text{C}$, $C_I = 0.1\ \mu\text{F}$, $C_O = 2.2\ \mu\text{F}$ unless otherwise specified.)

Symbol	Parameter	Test Conditions	Min.	Typ.	Max.	Unit
V_O	Output Voltage	$I_O = 50\ \text{mA}$, $V_I = 5.5\ \text{V}$	3.43	3.5	3.57	V
		$I_O = 50\ \text{mA}$, $V_I = 5.5\ \text{V}$, $T_a = -25\ \text{to}\ 85^\circ\text{C}$	3.36		3.64	
V_I	Operating Input Voltage	$I_O = 500\ \text{mA}$			20	V
I_O	Output Current Limit			1		A
ΔV_O	Line Regulation	$V_I = 4.5\ \text{to}\ 20\ \text{V}$, $I_O = 5\ \text{mA}$		2	12	mV
ΔV_O	Load Regulation	$V_I = 4.8\ \text{V}$, $I_O = 5\ \text{to}\ 500\ \text{mA}$		2	50	mV
I_d	Quiescent Current	$V_I = 4.5\ \text{to}\ 20\ \text{V}$, $I_O = 0\ \text{mA}$	(ON MODE)	0.5	1	mA
		$V_I = 4.8\ \text{to}\ 20\ \text{V}$, $I_O = 500\ \text{mA}$			12	
		$V_I = 6\ \text{V}$	(OFF MODE)	50	100	μA
SVR	Supply Voltage Rejection	$I_O = 5\ \text{mA}$ $V_I = 5.5 \pm 1\ \text{V}$	$f = 120\ \text{Hz}$	79		dB
			$f = 1\ \text{KHz}$	74		
			$f = 10\ \text{KHz}$	60		
eN	Output Noise Voltage	$B = 10\ \text{Hz to}\ 100\ \text{KHz}$		50		μV
V_d	Dropout Voltage	$I_O = 200\ \text{mA}$		0.2	0.35	V
		$I_O = 500\ \text{mA}$		0.4	0.7	
V_{IL}	Control Input Logic Low	$T_a = -40\ \text{to}\ 125^\circ\text{C}$			0.8	V
V_{IH}	Control Input Logic High	$T_a = -40\ \text{to}\ 125^\circ\text{C}$	2			V
I_I	Control Input Current	$V_I = 6\ \text{V}$, $V_C = 6\ \text{V}$		10		μA
C_O	Output Bypass Capacitance	$\text{ESR} = 0.1\ \text{to}\ 10\ \Omega$, $I_O = 0\ \text{to}\ 500\ \text{mA}$	2	10		μF

ELECTRICAL CHARACTERISTICS FOR KF40 (refer to the test circuits, $T_j = 25^\circ\text{C}$, $C_I = 0.1\ \mu\text{F}$, $C_O = 2.2\ \mu\text{F}$ unless otherwise specified.)

Symbol	Parameter	Test Conditions	Min.	Typ.	Max.	Unit
V_O	Output Voltage	$I_O = 50\ \text{mA}$, $V_I = 6\ \text{V}$	3.92	4	4.08	V
		$I_O = 50\ \text{mA}$, $V_I = 6\ \text{V}$, $T_a = -25\ \text{to}\ 85^\circ\text{C}$	3.84		4.16	
V_I	Operating Input Voltage	$I_O = 500\ \text{mA}$			20	V
I_O	Output Current Limit			1		A
ΔV_O	Line Regulation	$V_I = 5\ \text{to}\ 20\ \text{V}$, $I_O = 5\ \text{mA}$		3	18	mV
ΔV_O	Load Regulation	$V_I = 5.3\ \text{V}$, $I_O = 5\ \text{to}\ 500\ \text{mA}$		2	50	mV
I_d	Quiescent Current	$V_I = 5\ \text{to}\ 20\ \text{V}$, $I_O = 0\ \text{mA}$	(ON MODE)	0.5	1	mA
		$V_I = 5.3\ \text{to}\ 20\ \text{V}$, $I_O = 500\ \text{mA}$			12	
		$V_I = 6\ \text{V}$	(OFF MODE)	50	100	μA
SVR	Supply Voltage Rejection	$I_O = 5\ \text{mA}$ $V_I = 6 \pm 1\ \text{V}$	$f = 120\ \text{Hz}$	78		dB
			$f = 1\ \text{KHz}$	73		
			$f = 10\ \text{KHz}$	60		
eN	Output Noise Voltage	$B = 10\ \text{Hz to}\ 100\ \text{KHz}$		50		μV
V_d	Dropout Voltage	$I_O = 200\ \text{mA}$		0.2	0.35	V
		$I_O = 500\ \text{mA}$		0.4	0.7	
V_{IL}	Control Input Logic Low	$T_a = -40\ \text{to}\ 125^\circ\text{C}$			0.8	V
V_{IH}	Control Input Logic High	$T_a = -40\ \text{to}\ 125^\circ\text{C}$	2			V
I_I	Control Input Current	$V_I = 6\ \text{V}$, $V_C = 6\ \text{V}$		10		μA
C_O	Output Bypass Capacitance	$\text{ESR} = 0.1\ \text{to}\ 10\ \Omega$, $I_O = 0\ \text{to}\ 500\ \text{mA}$	2	10		μF

ELECTRICAL CHARACTERISTICS FOR KF45 (refer to the test circuits, $T_j = 25^\circ\text{C}$, $C_I = 0.1\ \mu\text{F}$, $C_O = 2.2\ \mu\text{F}$ unless otherwise specified.)

Symbol	Parameter	Test Conditions	Min.	Typ.	Max.	Unit
V_O	Output Voltage	$I_O = 50\ \text{mA}$, $V_I = 6.5\ \text{V}$	4.41	4.5	4.59	V
		$I_O = 50\ \text{mA}$, $V_I = 6.5\ \text{V}$, $T_a = -25\ \text{to}\ 85^\circ\text{C}$	4.32		4.68	
V_I	Operating Input Voltage	$I_O = 500\ \text{mA}$			20	V
I_O	Output Current Limit			1		A
ΔV_O	Line Regulation	$V_I = 5.5\ \text{to}\ 20\ \text{V}$, $I_O = 5\ \text{mA}$		3	18	mV
ΔV_O	Load Regulation	$V_I = 5.8\ \text{V}$, $I_O = 5\ \text{to}\ 500\ \text{mA}$		2	50	mV
I_d	Quiescent Current	$V_I = 5.5\ \text{to}\ 20\ \text{V}$, $I_O = 0\ \text{mA}$	(ON MODE)	0.5	1	mA
		$V_I = 5.8\ \text{to}\ 20\ \text{V}$, $I_O = 500\ \text{mA}$			12	
		$V_I = 6\ \text{V}$	(OFF MODE)	50	100	μA
SVR	Supply Voltage Rejection	$I_O = 5\ \text{mA}$ $V_I = 6.5 \pm 1\ \text{V}$	$f = 120\ \text{Hz}$	77		dB
			$f = 1\ \text{KHz}$	72		
			$f = 10\ \text{KHz}$	60		
eN	Output Noise Voltage	$B = 10\ \text{Hz to}\ 100\ \text{KHz}$		50		μV
V_d	Dropout Voltage	$I_O = 200\ \text{mA}$		0.2	0.35	V
		$I_O = 500\ \text{mA}$		0.4	0.7	
V_{IL}	Control Input Logic Low	$T_a = -40\ \text{to}\ 125^\circ\text{C}$			0.8	V
V_{IH}	Control Input Logic High	$T_a = -40\ \text{to}\ 125^\circ\text{C}$	2			V
I_I	Control Input Current	$V_I = 6\ \text{V}$, $V_C = 6\ \text{V}$		10		μA
C_O	Output Bypass Capacitance	$\text{ESR} = 0.1\ \text{to}\ 10\ \Omega$, $I_O = 0\ \text{to}\ 500\ \text{mA}$	2	10		μF

KF00

ELECTRICAL CHARACTERISTICS FOR KF47 (refer to the test circuits, $T_j = 25^\circ\text{C}$, $C_I = 0.1\ \mu\text{F}$, $C_O = 2.2\ \mu\text{F}$ unless otherwise specified.)

Symbol	Parameter	Test Conditions	Min.	Typ.	Max.	Unit
V_O	Output Voltage	$I_O = 50\ \text{mA}$, $V_I = 6.7\ \text{V}$	4.606	4.7	4.794	V
		$I_O = 50\ \text{mA}$, $V_I = 6.7\ \text{V}$, $T_a = -25\ \text{to}\ 85^\circ\text{C}$	4.512		4.888	
V_I	Operating Input Voltage	$I_O = 500\ \text{mA}$			20	V
I_O	Output Current Limit			1		A
ΔV_O	Line Regulation	$V_I = 5.7\ \text{to}\ 20\ \text{V}$, $I_O = 5\ \text{mA}$		3	18	mV
ΔV_O	Load Regulation	$V_I = 6\ \text{V}$, $I_O = 5\ \text{to}\ 500\ \text{mA}$		2	50	mV
I_d	Quiescent Current	$V_I = 5.7\ \text{to}\ 20\ \text{V}$, $I_O = 0\ \text{mA}$	(ON MODE)	0.5	1	mA
		$V_I = 6\ \text{to}\ 20\ \text{V}$, $I_O = 500\ \text{mA}$			12	
		$V_I = 6\ \text{V}$	(OFF MODE)	50	100	μA
SVR	Supply Voltage Rejection	$I_O = 5\ \text{mA}$ $V_I = 6.7 \pm 1\ \text{V}$	$f = 120\ \text{Hz}$	77		dB
			$f = 1\ \text{KHz}$	72		
			$f = 10\ \text{KHz}$	60		
eN	Output Noise Voltage	$B = 10\ \text{Hz to}\ 100\ \text{KHz}$		50		μV
V_d	Dropout Voltage	$I_O = 200\ \text{mA}$		0.2	0.35	V
		$I_O = 500\ \text{mA}$		0.4	0.7	
V_{IL}	Control Input Logic Low	$T_a = -40\ \text{to}\ 125^\circ\text{C}$			0.8	V
V_{IH}	Control Input Logic High	$T_a = -40\ \text{to}\ 125^\circ\text{C}$	2			V
I_I	Control Input Current	$V_I = 6\ \text{V}$, $V_C = 6\ \text{V}$		10		μA
C_O	Output Bypass Capacitance	$\text{ESR} = 0.1\ \text{to}\ 10\ \Omega$, $I_O = 0\ \text{to}\ 500\ \text{mA}$	2	10		μF

ELECTRICAL CHARACTERISTICS FOR KF50 (refer to the test circuits, $T_j = 25^\circ\text{C}$, $C_I = 0.1\ \mu\text{F}$, $C_O = 2.2\ \mu\text{F}$ unless otherwise specified.)

Symbol	Parameter	Test Conditions	Min.	Typ.	Max.	Unit
V_O	Output Voltage	$I_O = 50\ \text{mA}$, $V_I = 7\ \text{V}$	4.9	5	5.1	V
		$I_O = 50\ \text{mA}$, $V_I = 7\ \text{V}$, $T_a = -25\ \text{to}\ 85^\circ\text{C}$	4.8		5.2	
V_I	Operating Input Voltage	$I_O = 500\ \text{mA}$			20	V
I_O	Output Current Limit			1		A
ΔV_O	Line Regulation	$V_I = 6\ \text{to}\ 20\ \text{V}$, $I_O = 5\ \text{mA}$		3	18	mV
ΔV_O	Load Regulation	$V_I = 6.3\ \text{V}$, $I_O = 5\ \text{to}\ 500\ \text{mA}$		2	50	mV
I_d	Quiescent Current	$V_I = 6\ \text{to}\ 20\ \text{V}$, $I_O = 0\ \text{mA}$	(ON MODE)	0.5	1	mA
		$V_I = 6.3\ \text{to}\ 20\ \text{V}$, $I_O = 500\ \text{mA}$			12	
		$V_I = 6\ \text{V}$	(OFF MODE)	50	100	μA
SVR	Supply Voltage Rejection	$I_O = 5\ \text{mA}$ $V_I = 7 \pm 1\ \text{V}$	$f = 120\ \text{Hz}$	76		dB
			$f = 1\ \text{KHz}$	71		
			$f = 10\ \text{KHz}$	60		
eN	Output Noise Voltage	$B = 10\ \text{Hz to}\ 100\ \text{KHz}$		50		μV
V_d	Dropout Voltage	$I_O = 200\ \text{mA}$		0.2	0.35	V
		$I_O = 500\ \text{mA}$		0.4	0.7	
V_{IL}	Control Input Logic Low	$T_a = -40\ \text{to}\ 125^\circ\text{C}$			0.8	V
V_{IH}	Control Input Logic High	$T_a = -40\ \text{to}\ 125^\circ\text{C}$	2			V
I_I	Control Input Current	$V_I = 6\ \text{V}$, $V_C = 6\ \text{V}$		10		μA
C_O	Output Bypass Capacitance	$\text{ESR} = 0.1\ \text{to}\ 10\ \Omega$, $I_O = 0\ \text{to}\ 500\ \text{mA}$	2	10		μF

ELECTRICAL CHARACTERISTICS FOR KF52 (refer to the test circuits, $T_j = 25^\circ\text{C}$, $C_I = 0.1\ \mu\text{F}$, $C_O = 2.2\ \mu\text{F}$ unless otherwise specified.)

Symbol	Parameter	Test Conditions	Min.	Typ.	Max.	Unit
V_O	Output Voltage	$I_O = 50\ \text{mA}$, $V_I = 7.2\ \text{V}$	5.096	5.2	5.304	V
		$I_O = 50\ \text{mA}$, $V_I = 7.2\ \text{V}$, $T_a = -25\ \text{to}\ 85^\circ\text{C}$	4.992		5.408	
V_I	Operating Input Voltage	$I_O = 500\ \text{mA}$			20	V
I_O	Output Current Limit			1		A
ΔV_O	Line Regulation	$V_I = 6.2\ \text{to}\ 20\ \text{V}$, $I_O = 5\ \text{mA}$		3	18	mV
ΔV_O	Load Regulation	$V_I = 6.5\ \text{V}$, $I_O = 5\ \text{to}\ 500\ \text{mA}$		2	50	mV
I_d	Quiescent Current	$V_I = 6.2\ \text{to}\ 20\ \text{V}$, $I_O = 0\ \text{mA}$	(ON MODE)	0.5	1	mA
		$V_I = 6.5\ \text{to}\ 20\ \text{V}$, $I_O = 500\ \text{mA}$			12	
		$V_I = 6\ \text{V}$	(OFF MODE)	50	100	μA
SVR	Supply Voltage Rejection	$I_O = 5\ \text{mA}$ $V_I = 7.2 \pm 1\ \text{V}$	$f = 120\ \text{Hz}$	76		dB
			$f = 1\ \text{KHz}$	71		
			$f = 10\ \text{KHz}$	60		
eN	Output Noise Voltage	$B = 10\ \text{Hz to}\ 100\ \text{KHz}$		50		μV
V_d	Dropout Voltage	$I_O = 200\ \text{mA}$		0.2	0.35	V
		$I_O = 500\ \text{mA}$		0.4	0.7	
V_{IL}	Control Input Logic Low	$T_a = -40\ \text{to}\ 125^\circ\text{C}$			0.8	V
V_{IH}	Control Input Logic High	$T_a = -40\ \text{to}\ 125^\circ\text{C}$	2			V
I_I	Control Input Current	$V_I = 6\ \text{V}$, $V_C = 6\ \text{V}$		10		μA
C_O	Output Bypass Capacitance	$\text{ESR} = 0.1\ \text{to}\ 10\ \Omega$, $I_O = 0\ \text{to}\ 500\ \text{mA}$	2	10		μF

ELECTRICAL CHARACTERISTICS FOR KF55 (refer to the test circuits, $T_j = 25^\circ\text{C}$, $C_I = 0.1\ \mu\text{F}$, $C_O = 2.2\ \mu\text{F}$ unless otherwise specified.)

Symbol	Parameter	Test Conditions	Min.	Typ.	Max.	Unit
V_O	Output Voltage	$I_O = 50\ \text{mA}$, $V_I = 7.5\ \text{V}$	5.39	5.5	5.61	V
		$I_O = 50\ \text{mA}$, $V_I = 7.5\ \text{V}$, $T_a = -25\ \text{to}\ 85^\circ\text{C}$	5.28		5.72	
V_I	Operating Input Voltage	$I_O = 500\ \text{mA}$			20	V
I_O	Output Current Limit			1		A
ΔV_O	Line Regulation	$V_I = 6.5\ \text{to}\ 20\ \text{V}$, $I_O = 5\ \text{mA}$		3	18	mV
ΔV_O	Load Regulation	$V_I = 6.8\ \text{V}$, $I_O = 5\ \text{to}\ 500\ \text{mA}$		2	50	mV
I_d	Quiescent Current	$V_I = 6.5\ \text{to}\ 20\ \text{V}$, $I_O = 0\ \text{mA}$	(ON MODE)	0.5	1	mA
		$V_I = 6.8\ \text{to}\ 20\ \text{V}$, $I_O = 500\ \text{mA}$			12	
		$V_I = 6\ \text{V}$	(OFF MODE)	50	100	μA
SVR	Supply Voltage Rejection	$I_O = 5\ \text{mA}$ $V_I = 7.5 \pm 1\ \text{V}$	$f = 120\ \text{Hz}$	76		dB
			$f = 1\ \text{KHz}$	71		
			$f = 10\ \text{KHz}$	60		
eN	Output Noise Voltage	$B = 10\ \text{Hz to}\ 100\ \text{KHz}$		50		μV
V_d	Dropout Voltage	$I_O = 200\ \text{mA}$		0.2	0.35	V
		$I_O = 500\ \text{mA}$		0.4	0.7	
V_{IL}	Control Input Logic Low	$T_a = -40\ \text{to}\ 125^\circ\text{C}$			0.8	V
V_{IH}	Control Input Logic High	$T_a = -40\ \text{to}\ 125^\circ\text{C}$	2			V
I_I	Control Input Current	$V_I = 6\ \text{V}$, $V_C = 6\ \text{V}$		10		μA
C_O	Output Bypass Capacitance	$\text{ESR} = 0.1\ \text{to}\ 10\ \Omega$, $I_O = 0\ \text{to}\ 500\ \text{mA}$	2	10		μF

KF00

ELECTRICAL CHARACTERISTICS FOR KF60 (refer to the test circuits, $T_j = 25^\circ\text{C}$, $C_I = 0.1\ \mu\text{F}$, $C_O = 2.2\ \mu\text{F}$ unless otherwise specified.)

Symbol	Parameter	Test Conditions	Min.	Typ.	Max.	Unit
V_O	Output Voltage	$I_O = 50\ \text{mA}$, $V_I = 8\ \text{V}$	5.88	6	6.12	V
		$I_O = 50\ \text{mA}$, $V_I = 8\ \text{V}$, $T_a = -25\ \text{to}\ 85^\circ\text{C}$	5.76		6.24	
V_I	Operating Input Voltage	$I_O = 500\ \text{mA}$			20	V
I_O	Output Current Limit			1		A
ΔV_O	Line Regulation	$V_I = 7\ \text{to}\ 20\ \text{V}$, $I_O = 5\ \text{mA}$		4	24	mV
ΔV_O	Load Regulation	$V_I = 7.3\ \text{V}$, $I_O = 5\ \text{to}\ 500\ \text{mA}$		2	50	mV
I_d	Quiescent Current	$V_I = 7\ \text{to}\ 20\ \text{V}$, $I_O = 0\ \text{mA}$	(ON MODE)	0.7	1.5	mA
		$V_I = 7.3\ \text{to}\ 20\ \text{V}$, $I_O = 500\ \text{mA}$			12	
		$V_I = 9\ \text{V}$	(OFF MODE)	70	140	μA
SVR	Supply Voltage Rejection	$I_O = 5\ \text{mA}$ $V_I = 8 \pm 1\ \text{V}$	$f = 120\ \text{Hz}$	75		dB
			$f = 1\ \text{KHz}$	70		
			$f = 10\ \text{KHz}$	60		
eN	Output Noise Voltage	$B = 10\ \text{Hz to}\ 100\ \text{KHz}$		50		μV
V_d	Dropout Voltage	$I_O = 200\ \text{mA}$		0.2	0.35	V
		$I_O = 500\ \text{mA}$		0.4	0.7	
V_{IL}	Control Input Logic Low	$T_a = -40\ \text{to}\ 125^\circ\text{C}$			0.8	V
V_{IH}	Control Input Logic High	$T_a = -40\ \text{to}\ 125^\circ\text{C}$	2			V
I_I	Control Input Current	$V_I = 9\ \text{V}$, $V_C = 6\ \text{V}$		10		μA
C_O	Output Bypass Capacitance	$\text{ESR} = 0.1\ \text{to}\ 10\ \Omega$, $I_O = 0\ \text{to}\ 500\ \text{mA}$	2	10		μF

ELECTRICAL CHARACTERISTICS FOR KF80B (refer to the test circuits, $T_j = 25^\circ\text{C}$, $C_I = 0.1\ \mu\text{F}$, $C_O = 2.2\ \mu\text{F}$ unless otherwise specified.)

Symbol	Parameter	Test Conditions	Min.	Typ.	Max.	Unit
V_O	Output Voltage	$I_O = 50\ \text{mA}$, $V_I = 10\ \text{V}$	7.84	8	8.16	V
		$I_O = 50\ \text{mA}$, $V_I = 10\ \text{V}$, $T_a = -25\ \text{to}\ 85^\circ\text{C}$	7.68		8.32	
V_I	Operating Input Voltage	$I_O = 500\ \text{mA}$			20	V
I_O	Output Current Limit			1		A
ΔV_O	Line Regulation	$V_I = 9\ \text{to}\ 20\ \text{V}$, $I_O = 5\ \text{mA}$		4	24	mV
ΔV_O	Load Regulation	$V_I = 9.3\ \text{V}$, $I_O = 5\ \text{to}\ 500\ \text{mA}$		2	50	mV
I_d	Quiescent Current	$V_I = 9\ \text{to}\ 20\ \text{V}$, $I_O = 0\ \text{mA}$	(ON MODE)	0.7	1.5	mA
		$V_I = 9.3\ \text{to}\ 20\ \text{V}$, $I_O = 500\ \text{mA}$			12	
		$V_I = 9\ \text{V}$	(OFF MODE)	70	140	μA
SVR	Supply Voltage Rejection	$I_O = 5\ \text{mA}$ $V_I = 10 \pm 1\ \text{V}$	$f = 120\ \text{Hz}$	72		dB
			$f = 1\ \text{KHz}$	67		
			$f = 10\ \text{KHz}$	60		
eN	Output Noise Voltage	$B = 10\ \text{Hz to}\ 100\ \text{KHz}$		50		μV
V_d	Dropout Voltage	$I_O = 200\ \text{mA}$		0.2	0.35	V
		$I_O = 500\ \text{mA}$		0.4	0.7	
V_{IL}	Control Input Logic Low	$T_a = -40\ \text{to}\ 125^\circ\text{C}$			0.8	V
V_{IH}	Control Input Logic High	$T_a = -40\ \text{to}\ 125^\circ\text{C}$	2			V
I_I	Control Input Current	$V_I = 9\ \text{V}$, $V_C = 6\ \text{V}$		10		μA
C_O	Output Bypass Capacitance	$\text{ESR} = 0.1\ \text{to}\ 10\ \Omega$, $I_O = 0\ \text{to}\ 500\ \text{mA}$	2	10		μF

ELECTRICAL CHARACTERISTICS FOR KF85B (refer to the test circuits, $T_j = 25^\circ\text{C}$, $C_I = 0.1\ \mu\text{F}$, $C_O = 2.2\ \mu\text{F}$ unless otherwise specified.)

Symbol	Parameter	Test Conditions	Min.	Typ.	Max.	Unit
V_O	Output Voltage	$I_O = 50\ \text{mA}$, $V_I = 10.5\ \text{V}$	8.33	8.5	8.67	V
		$I_O = 50\ \text{mA}$, $V_I = 10.5\ \text{V}$, $T_a = -25\ \text{to}\ 85^\circ\text{C}$	8.16		8.84	
V_I	Operating Input Voltage	$I_O = 500\ \text{mA}$			20	V
I_O	Output Current Limit			1		A
ΔV_O	Line Regulation	$V_I = 9.5\ \text{to}\ 20\ \text{V}$, $I_O = 5\ \text{mA}$		4	24	mV
ΔV_O	Load Regulation	$V_I = 9.8\ \text{V}$, $I_O = 5\ \text{to}\ 500\ \text{mA}$		2	50	mV
I_d	Quiescent Current	$V_I = 9.5\ \text{to}\ 20\ \text{V}$, $I_O = 0\ \text{mA}$	(ON MODE)	0.7	1.5	mA
		$V_I = 9.8\ \text{to}\ 20\ \text{V}$, $I_O = 500\ \text{mA}$			12	
		$V_I = 10\ \text{V}$	(OFF MODE)	70	140	μA
SVR	Supply Voltage Rejection	$I_O = 5\ \text{mA}$ $V_I = 10.5 \pm 1\ \text{V}$	$f = 120\ \text{Hz}$	67		dB
			$f = 1\ \text{KHz}$	63		
			$f = 10\ \text{KHz}$	53		
eN	Output Noise Voltage	$B = 10\ \text{Hz to}\ 100\ \text{KHz}$		50		μV
V_d	Dropout Voltage	$I_O = 200\ \text{mA}$		0.2	0.35	V
		$I_O = 500\ \text{mA}$		0.4	0.7	
V_{IL}	Control Input Logic Low	$T_a = -40\ \text{to}\ 125^\circ\text{C}$			0.8	V
V_{IH}	Control Input Logic High	$T_a = -40\ \text{to}\ 125^\circ\text{C}$	2			V
I_I	Control Input Current	$V_I = 10\ \text{V}$, $V_C = 6\ \text{V}$		10		μA
C_O	Output Bypass Capacitance	$\text{ESR} = 0.1\ \text{to}\ 10\ \Omega$, $I_O = 0\ \text{to}\ 500\ \text{mA}$	2	10		μF

ELECTRICAL CHARACTERISTICS FOR KF120B (refer to the test circuits, $T_j = 25^\circ\text{C}$, $C_I = 0.1\ \mu\text{F}$, $C_O = 2.2\ \mu\text{F}$ unless otherwise specified.)

Symbol	Parameter	Test Conditions	Min.	Typ.	Max.	Unit
V_O	Output Voltage	$I_O = 50\ \text{mA}$, $V_I = 14\ \text{V}$	11.76	12	12.24	V
		$I_O = 50\ \text{mA}$, $V_I = 14\ \text{V}$, $T_a = -25\ \text{to}\ 85^\circ\text{C}$	11.52		12.48	
V_I	Operating Input Voltage	$I_O = 500\ \text{mA}$			20	V
I_O	Output Current Limit			1		A
ΔV_O	Line Regulation	$V_I = 13\ \text{to}\ 20\ \text{V}$, $I_O = 5\ \text{mA}$		8	48	mV
ΔV_O	Load Regulation	$V_I = 13.3\ \text{V}$, $I_O = 5\ \text{to}\ 500\ \text{mA}$		2	50	mV
I_d	Quiescent Current	$V_I = 13\ \text{to}\ 20\ \text{V}$, $I_O = 0\ \text{mA}$	(ON MODE)	0.7	1.5	mA
		$V_I = 13.3\ \text{to}\ 20\ \text{V}$, $I_O = 500\ \text{mA}$			12	
		$V_I = 13\ \text{V}$	(OFF MODE)	70	140	μA
SVR	Supply Voltage Rejection	$I_O = 5\ \text{mA}$ $V_I = 14 \pm 1\ \text{V}$	$f = 120\ \text{Hz}$	69		dB
			$f = 1\ \text{KHz}$	64		
			$f = 10\ \text{KHz}$	54		
eN	Output Noise Voltage	$B = 10\ \text{Hz to}\ 100\ \text{KHz}$		50		μV
V_d	Dropout Voltage	$I_O = 200\ \text{mA}$		0.2	0.35	V
		$I_O = 500\ \text{mA}$		0.4	0.7	
V_{IL}	Control Input Logic Low	$T_a = -40\ \text{to}\ 125^\circ\text{C}$			0.8	V
V_{IH}	Control Input Logic High	$T_a = -40\ \text{to}\ 125^\circ\text{C}$	2			V
I_I	Control Input Current	$V_I = 13\ \text{V}$, $V_C = 6\ \text{V}$		10		μA
C_O	Output Bypass Capacitance	$\text{ESR} = 0.1\ \text{to}\ 10\ \Omega$, $I_O = 0\ \text{to}\ 500\ \text{mA}$	2	10		μF

TYPICAL PERFORMANCE CHARACTERISTICS (unless otherwise specified $V_{O(NOM)} = 3.3\text{ V}$)

Figure 1 : Dropout Voltage vs Output Current

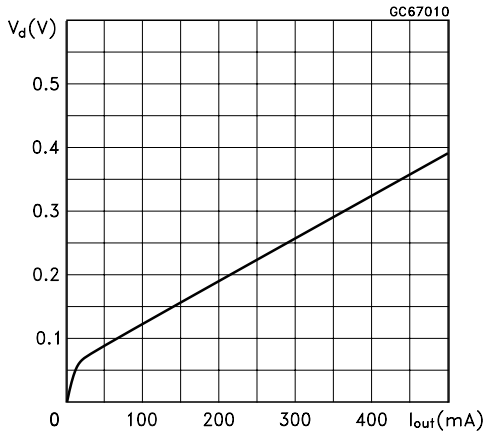

Figure 4 : Supply Current vs Input Voltage

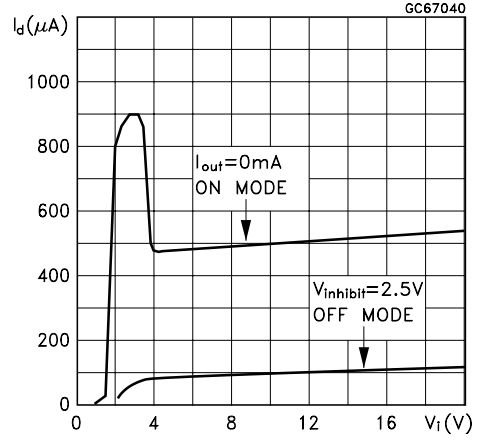

Figure 2 : Dropout Voltage vs Temperature

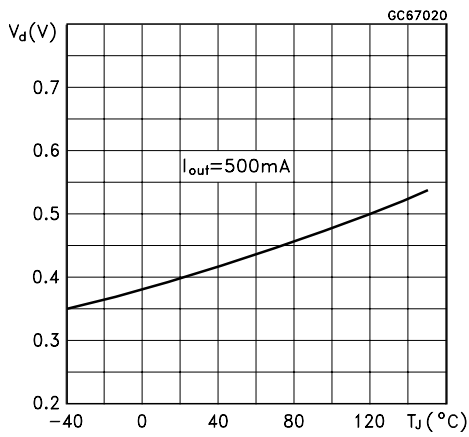

Figure 5 : Short Circuit Current vs Input Voltage

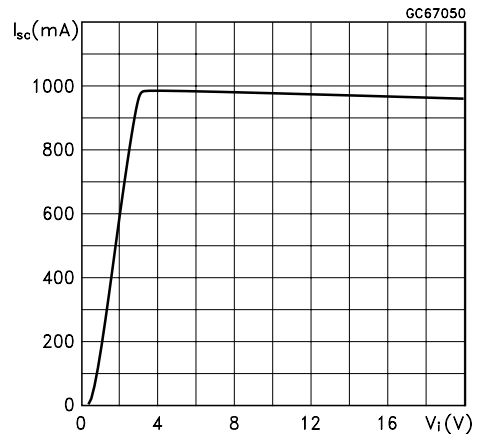

Figure 3 : Supply Current vs Input Voltage

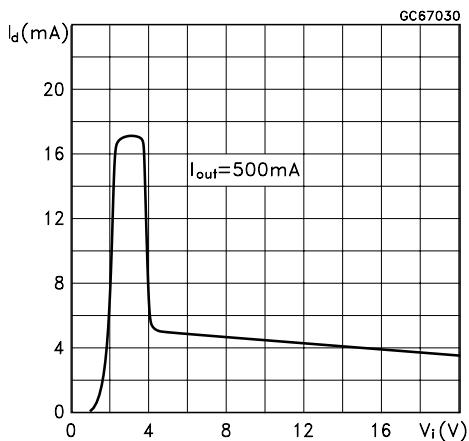
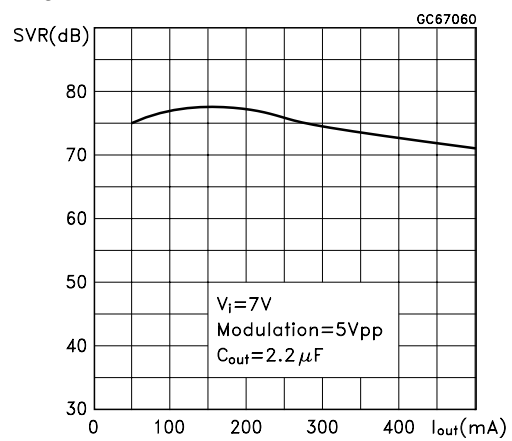
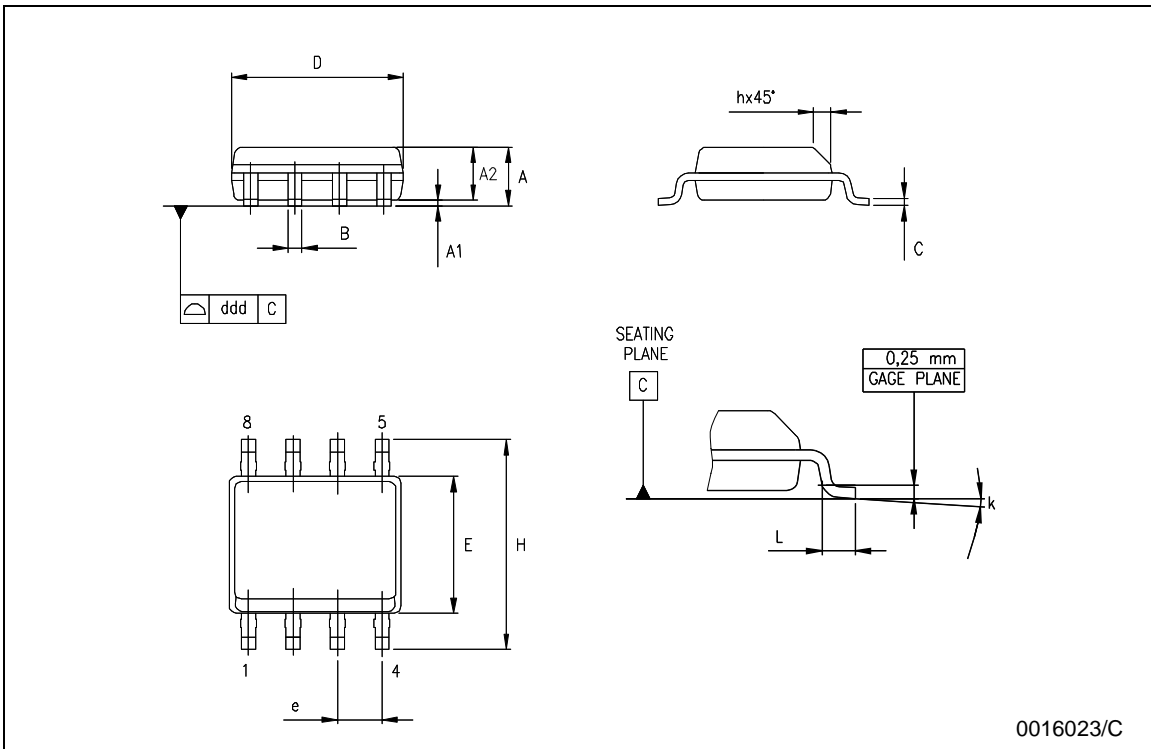

Figure 6 : Supply Voltage Rejection vs Input Voltage



SO-8 MECHANICAL DATA

DIM.	mm.			inch		
	MIN.	TYP	MAX.	MIN.	TYP.	MAX.
A	1.35		1.75	0.053		0.069
A1	0.10		0.25	0.04		0.010
A2	1.10		1.65	0.043		0.065
B	0.33		0.51	0.013		0.020
C	0.19		0.25	0.007		0.010
D	4.80		5.00	0.189		0.197
E	3.80		4.00	0.150		0.157
e		1.27			0.050	
H	5.80		6.20	0.228		0.244
h	0.25		0.50	0.010		0.020
L	0.40		1.27	0.016		0.050
k	8° (max.)					
ddd			0.1			0.04



0016023/C



DPAK MECHANICAL DATA

DIM.	mm.			inch		
	MIN.	TYP	MAX.	MIN.	TYP.	MAX.
A	2.2		2.4	0.086		0.094
A1	0.9		1.1	0.035		0.043
A2	0.03		0.23	0.001		0.009
B	0.64		0.9	0.025		0.035
B2	5.2		5.4	0.204		0.212
C	0.45		0.6	0.017		0.023
C2	0.48		0.6	0.019		0.023
D	6		6.2	0.236		0.244
D1		5.1			0.200	
E	6.4		6.6	0.252		0.260
E1		4.7			0.185	
e		2.28			0.090	
e1	4.4		4.6	0.173		0.181
H	9.35		10.1	0.368		0.397
L		1			0.039	
(L1)		2.8			0.110	
L2		0.8			0.031	
L4	0.6		1	0.023		0.039

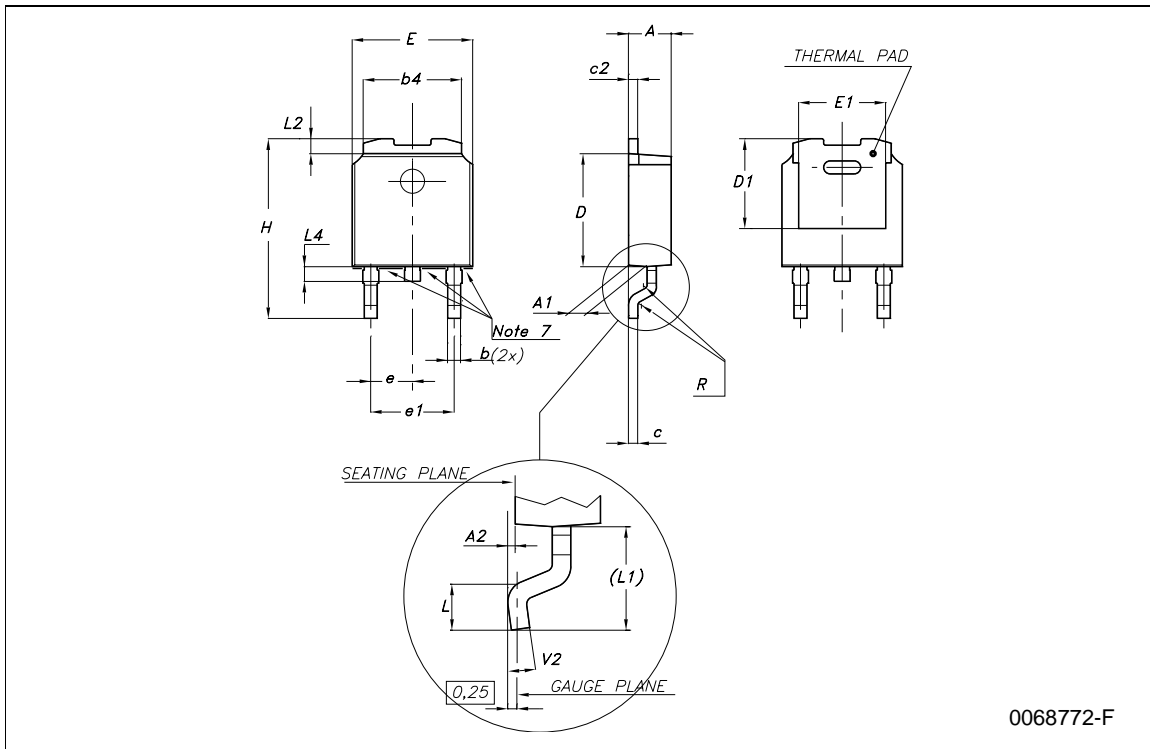

Tape & Reel SO-8 MECHANICAL DATA

DIM.	mm.			inch		
	MIN.	TYP	MAX.	MIN.	TYP.	MAX.
A			330			12.992
C	12.8		13.2	0.504		0.519
D	20.2			0.795		
N	60			2.362		
T			22.4			0.882
Ao	8.1		8.5	0.319		0.335
Bo	5.5		5.9	0.216		0.232
Ko	2.1		2.3	0.082		0.090
Po	3.9		4.1	0.153		0.161
P	7.9		8.1	0.311		0.319

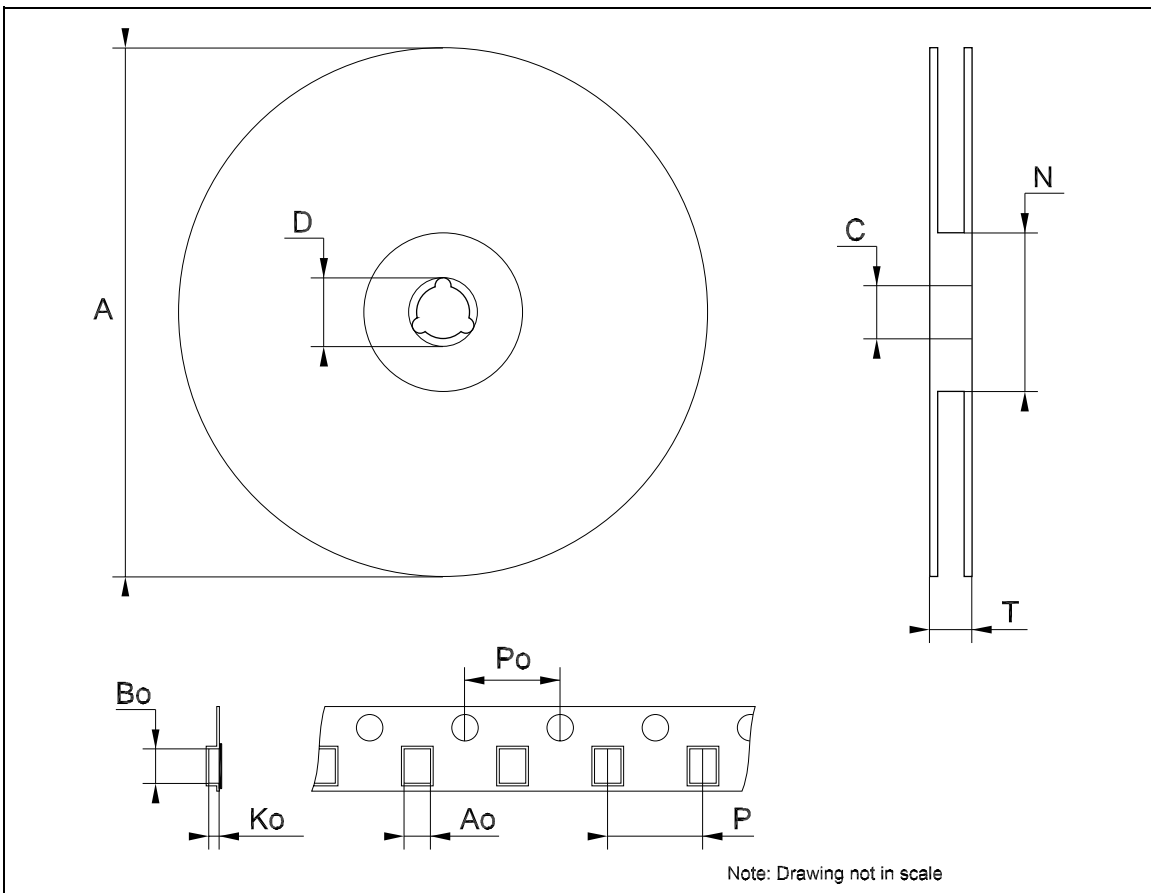

Tape & Reel DPAK-PPAK MECHANICAL DATA

DIM.	mm.			inch		
	MIN.	TYP	MAX.	MIN.	TYP.	MAX.
A			330			12.992
C	12.8	13.0	13.2	0.504	0.512	0.519
D	20.2			0.795		
N	60			2.362		
T			22.4			0.882
Ao	6.80	6.90	7.00	0.268	0.272	0.276
Bo	10.40	10.50	10.60	0.409	0.413	0.417
Ko	2.55	2.65	2.75	0.100	0.104	0.105
Po	3.9	4.0	4.1	0.153	0.157	0.161
P	7.9	8.0	8.1	0.311	0.315	0.319

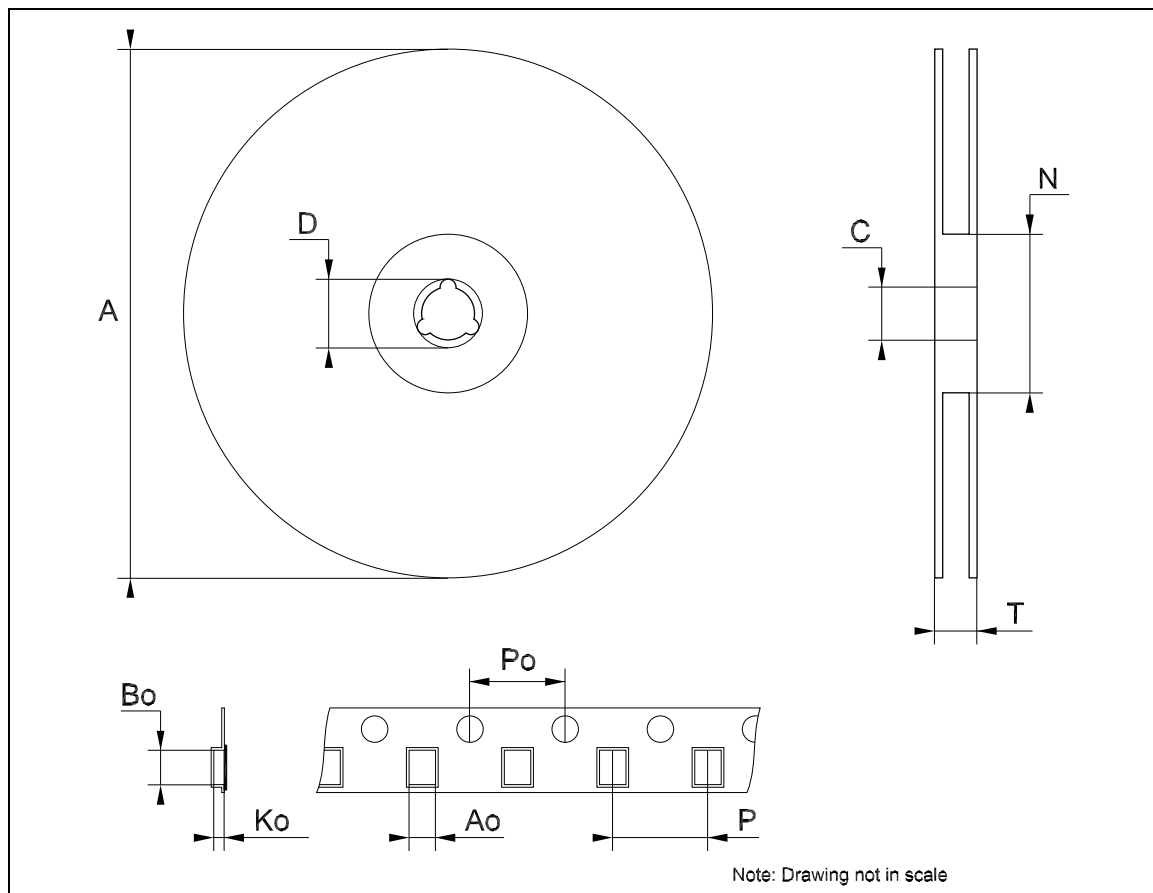

Information furnished is believed to be accurate and reliable. However, STMicroelectronics assumes no responsibility for the consequences of use of such information nor for any infringement of patents or other rights of third parties which may result from its use. No license is granted by implication or otherwise under any patent or patent rights of STMicroelectronics. Specifications mentioned in this publication are subject to change without notice. This publication supersedes and replaces all information previously supplied. STMicroelectronics products are not authorized for use as critical components in life support devices or systems without express written approval of STMicroelectronics.

The ST logo is a registered trademark of STMicroelectronics
All other names are the property of their respective owners

© 2004 STMicroelectronics - All Rights Reserved
STMicroelectronics GROUP OF COMPANIES

Australia - Belgium - Brazil - Canada - China - Czech Republic - Finland - France - Germany - Hong Kong - India - Israel - Italy - Japan - Malaysia - Malta - Morocco - Singapore - Spain - Sweden - Switzerland - United Kingdom - United States.
<http://www.st.com>

