

TOSHIBA Linear C-MOS Integrated Circuit Silicon Monolithic

TC90L01NG(TENTATIVE)

Audio/Video Switching IC for TVs

The TC90L01NG is an audio/video switching IC for TV sets.

Conforming to I²C bus standards, it allows you to perform various switching operations through the bus lines by using a microcomputer. This IC has the functions of audio mute, ALC(Auto Level Control), audio volume and so on.

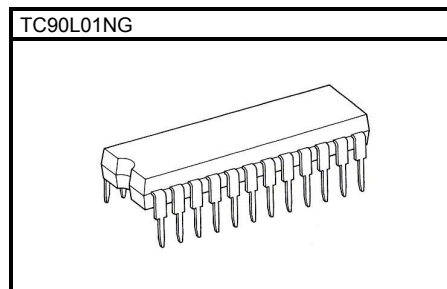

Weight
SDIP24-P-300-1.78 : 1.22 g (typ.)

Features

- I²C bus control
- Video : 3-channel inputs and 1-channel outputs
(1 channels conforming to S system)
- Audio : 3-channel inputs and 1-channel outputs
- Monitor Audio out
- ALC(Auto Level Control)
- Audio volume by attenuator circuit
- Audio mute
- 2 I/O ports

Block Diagram

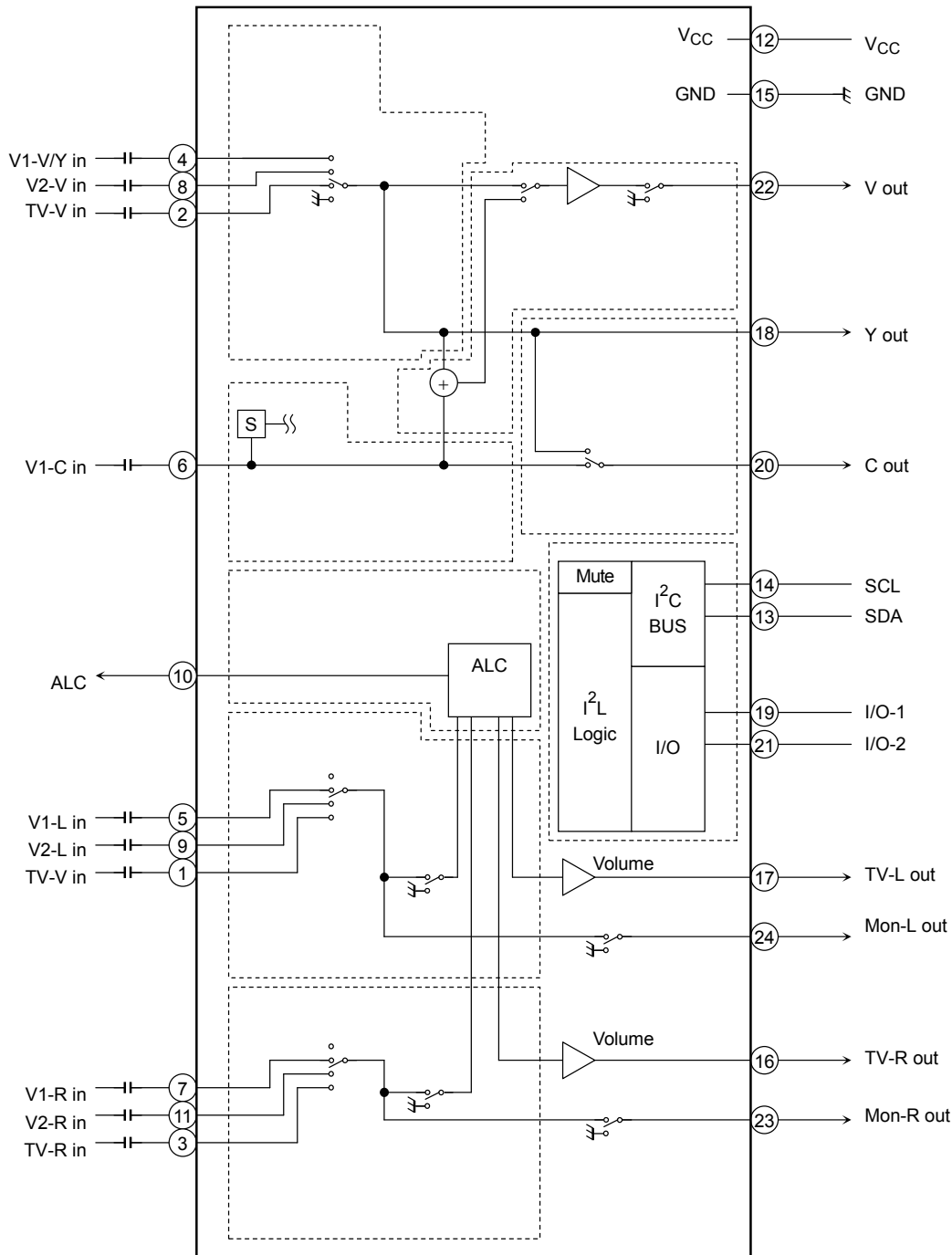

Pin Assignment

TC90L01NG

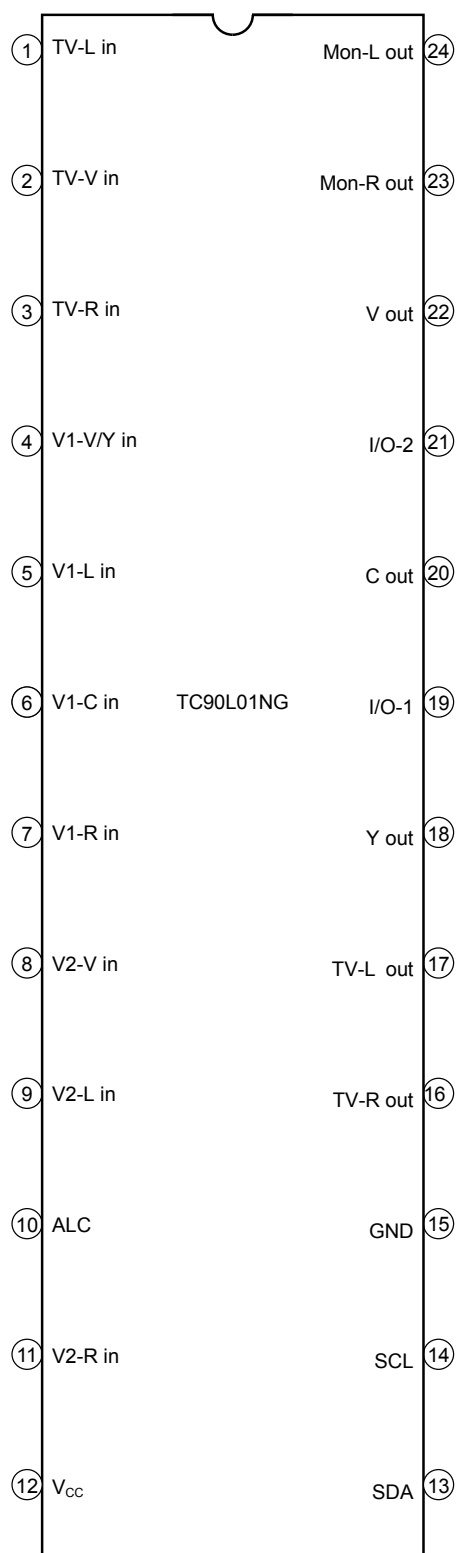

Pin Description

Pin No.	Name	Function	Interface
1	TV-L in	<p>This pin is for input a left audio signal from the main demodulator in the TV set. The signal fed into this pin is presented to TV-L out, and Mon-L out.</p> <p>The input dynamic range of this pin is $5.0 V_{p-p}$ and the input resistance is $120 k\Omega$.</p>	
2	TV-V in	<p>This pin is for input a composite audio signal from the main demodulator in the TV set. The signal fed into this pin is presented to V out, Y out, and C out.</p> <p>The input dynamic range of this pin is $2.0 V_{p-p}$ and the input resistance is $30 k\Omega$.</p>	
3	TV-R in	<p>This pin is for input a right audio signal from the main demodulator in the TV set. The signal fed into this pin is presented to TV-R out, and Mon-R out.</p> <p>The input dynamic range of this pin is $5.0 V_{p-p}$ and the input resistance is $120 k\Omega$.</p>	
4	V1-V/Y in	<p>This pin is for input a luminance signal or composite video signal from an external source (V1 channel). The signal fed into this pin is presented to V out, Y out, and C out.</p> <p>The input dynamic range of this pin is $2.0 V_{p-p}$ and the input resistance is $30 k\Omega$.</p>	

Pin No.	Name	Function	Interface
5	V1-L in	<p>This pin is for input a left audio signal from an external source (V1 channel). The signal fed into this pin is presented to TV-L out, and Mon-L out.</p> <p>The input dynamic range of this pin is 5.0 V_{p-p} and the input resistance is 120kΩ.</p>	
6	V1-C in	<p>This pin is for input a chroma signal from an external source (S1 channel). The signal fed into this pin is presented to C out directly and to V out after being combined with the V1-Y in signal.</p> <p>The input dynamic range of this pin is 2.0 V_{p-p} and the input resistance is 30 kΩ.</p>	
7	V1-R in	<p>This pin is for input a right audio signal from an external source (V1 channel). The signal fed into this pin is presented to TV-R out, and Mon-R out.</p> <p>The input dynamic range of this pin is 5.0 V_{p-p} and the input resistance is 120 kΩ.</p>	
8	V2-V in	<p>This pin is for input a composite video signal from an external source (V2 channel). The signal fed into this pin is presented to V out, Y out, and C out.</p> <p>The input dynamic range of this pin is 2.0 V_{p-p} and the input resistance is 30 kΩ.</p>	

Pin No.	Name	Function	Interface
9	V2-L in	<p>This pin is for input a left audio signal from an external source (V2 channel). The signal fed into this pin is presented to TV-L out and Mon-L out.</p> <p>The input dynamic range of this pin is 5.0 V_{p-p} and the input resistance is 120Ω.</p>	
10	ALC	<p>This is an detect output pin of ALC[Auto Level Control]. It controls ALC.</p>	
11	V2-R in	<p>This pin is for input a right audio signal from an external source (V2 channel). The signal fed into this pin is presented to TV-R out and Mon-R out.</p> <p>The input dynamic range of this pin is 5.0 V_{p-p} and the input resistance is 120 kΩ.</p>	
12	V _{CC}	<p>This is the power supply pin. Apply 9 V to this pin. The current consumption of this pin is 34 mA.</p>	—
13	SDA	<p>This is an I²C bus data input/output pin. The input threshold level of this pin is 3.0 V.</p> <p>Make sure that the current flowing into this pin is 3.0 mA or less.</p>	

Pin No.	Name	Function	Interface
14	SCL	This is an I ² C bus data input/output pin. The input threshold level of this pin is 3.0 V.	<p>The diagram shows the SCL pin connected to a 5.0V supply through a pull-up resistor. A 3.0V threshold level is indicated by a downward arrow. The pin is connected to a logic block.</p>
15	GND	This is the GND pin.	—
16	TV-R out	This pin is for output right audio signal. The signal fed into TV-R in, V1-R in, or V2-R in is outputted from this pin. This outputted can be muted independently of TV-L out by bus control.	<p>The diagram shows a differential audio output stage. It consists of two transistors in a common-emitter configuration, with their emitters connected to a common point. The outputs are taken from the collectors through load resistors. The signal is labeled 'Audio Out'.</p>
17	TV-L out	This pin is for output left audio signal. The signal fed into TV-L in, V1-L in, or V2-L in is outputted from this pin. This output can be muted independently of TV-R out by bus control.	<p>The diagram shows a differential audio output stage, identical in structure to the TV-R out pin. It consists of two transistors in a common-emitter configuration, with their emitters connected to a common point. The outputs are taken from the collectors through load resistors. The signal is labeled 'Audio Out'.</p>
18	Y out	This pin is for output a luminance signal. The signal fed into V1-V/Y in, V2-V in, or TV-V in is outputted from this pin.	<p>The diagram shows a differential video output stage, identical in structure to the audio output pins. It consists of two transistors in a common-emitter configuration, with their emitters connected to a common point. The outputs are taken from the collectors through load resistors. The signal is labeled 'Video Out'.</p>

Pin No.	Name	Function	Interface
19	I/O-1	<p>This is an ADC input/DAC output pin.</p> <p>The ADC is a 2-level detection type (1 bits). The threshold level is 3.0 V.</p> <p>The DAC (1 bit) is an open-drain output. Make sure that the current flowing into this pin is 2.0 mA or less.</p>	
20	C out	<p>This pin is for output a chroma signal. The signal fed into V1-C in, V1-V in, V2-V in, or TV-V in is outputted from this pin.</p>	
21	I/O-2	<p>This is an ADC input/DAC output pin.</p> <p>The ADC is a 2-level detection type (1 bits). The threshold level is 3.0 V.</p> <p>The DAC (1 bit) is an open-drain output. Make sure that the current flowing into this pin is 2.0 mA or less.</p>	
22	V out	<p>This pin is for output the main channel composite video signal. The signal fed into TV-V in, V1-V in, V2-V in, or V1-Y in +V1-C in is outputted from this pin.</p> <p>This output can be muted by bus control.</p>	

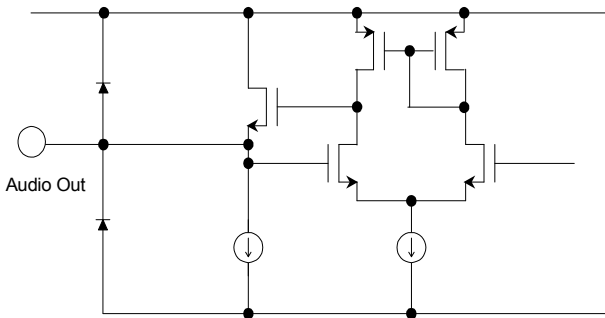
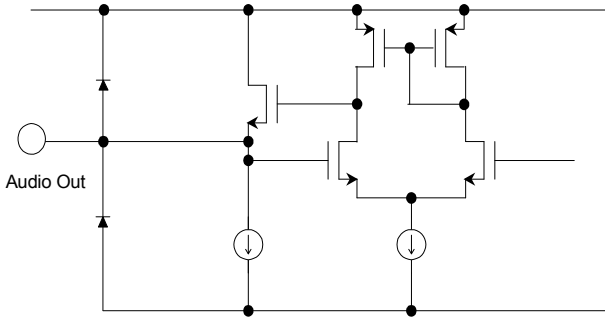
Pin No.	Name	Function	Interface
23	Mon-R out	<p>This pin is for monitor-output right audio signal. The signals fed into the chip via V1-R in, V2-R in, or TV-R in is output from this pin.</p> <p>This output can be muted in combination with Mon-L out by bus control.</p>	
24	Mon-L out	<p>This pin is for monitor-output left audio signal. The signals fed into the chip via V1-L in, V2-L in, or TV-L in is output from this pin.</p> <p>This output can be muted in combination with Mon-R out by bus control.</p>	

Bus Data Specifications

Contents of Data

Mode	Sub Add.	Data No. [Preset]	Contents of Data							
Write	00	Data 1 [00H]	B07	B06	B05	B04	B03	B02	B01	B00
			*	ALC Gain		Output switching				
					Select-D	Select-C	Select-B	Select-A		
	01	Data 2 [00H]	B17	B16	B15	B14	B13	B12	B11	B10
			Audio Mute	Audio attenuator						
	02	Data 3 [03H]	B27	B26	B25	B24	B23	B22	B21	B20
*			*	*	*	DAC output switching				
						*	*	I/O-2	I/O-1	
Read	-	Data 4	B37	B36	B35	B34	B33	B32	B31	B30
			Power on Reset	*	*	ADC input discrimination				S input discrimination
						*	*	I/O-2	I/O-1	V1-C in

Note1: The data contents marked by a * are an unused bit (data free).

WRITE mode Slave Add.=90H

Item	Bits	Descriptions	Preset
Select-A Sub; 00 h,D0~D1 (Note 2)	2	Select input function 00: T V 01: External 1 10: External 2 11: — (Inhibited)	00
Select-B Sub; 00 h,D2	1	C V B S or S-video switching 0: C V B S 1: S-video	0
Select-C Sub; 00 h,D3	1	Monitor-Video out 0: Normal 1: Mute	0
Select-D Sub; 00 h,D4	1	Monitor-Audio out 0: Normal 1: Mute	0
A L C Level Sub; 00 h,D5~D6	2	Audio Level Control Gain 00: A L C off 01: 1.1Vp-p 10: 1.6Vp-p 11: 2.3Vp-p	10
Audio Vol. Sub; 01h,D0~D6	7	Audio Volume 00: -∞ ~ 7F: 0dB	00
Audio mute on/off Sub; 01h,D7	1	Audio Mute 0: Normal 1: Mute	0
I/O-* High/Low Sub; 02h,D1,D2	1 × 2	DAC output switching 0: Low 1: High	1

Note 2 : Select-A = { 1 1 } not use.

READ mode Slave Add.=91H

Item	Bits	Description
POR	1	Power on Reset 0: Normal 1: Resister Preset
V1-C in	1	S input discrimination 0: GND 1: Open
I/O *	1 × 2	ADC input discrimination 0: Low 1: High

Video Select: Terminal 22 , 18 , 20 Output Signal

Audio Select: Terminal 17 , 16 , 24 , 23 Output Signal

Mode		Video Output Signal			Audio Output Signal		Bus Data		
							Input Select		
Input	S/V	V out	Y out	C out	TV-L out	TV-R out	B02	B01	B00
					Mon-L out	Mon-R out	B	A	
TV	CVBS	TV-V in	TV-V in	TV-V in	TV-L in	TV-R in	0	0	0
V1	CVBS	V1-V in	V1-V in	V1-V in	V1-L in	V1-R in	0	0	1
	S	V1-Y in + V1-C in	V1-Y in	V1-C in	V1-L in	V1-R in	1	0	1
V2	CVBS	V2-V in	V2-V in	V2-V in	V2-L in	V2-R in	0	1	0
V3	-	-	-	-	-	-	0	1	1

DAC Output Switching

Mode		Bus Data			
		DAC Output Switching			
Output	State	B23	B22	B21	B20
I/O-1	Low	*	*	*	0
	Open				1
I/O-2	Low	*	*	0	*
	Open			1	

Read Mode

Power-On Reset Discrimination

Mode		Bus Data	
		Power-On Reset	
		B37	
Reset	On (Preset)	1	
	off (Normal)	0	

S Input Discrimination

Mode		Bus Data	
		S Input Discrimination	
Input	Voltage	B30	
V1-C in	High (open)	1	
	Low	0	

ADC Input Discrimination

Mode		Bus Data			
		ADC Input Discrimination			
Input	Voltage	B34	B33	B32	B31
I/O-1	High	*	*	*	1
	Low	*	*	*	0
I/O-2	High	*	*	1	*
	Low	*	*	0	*

Outline of I²C Bus Control Format

DATA TRANSFER FORMAT VIA I²C BUS

Start and stop condition

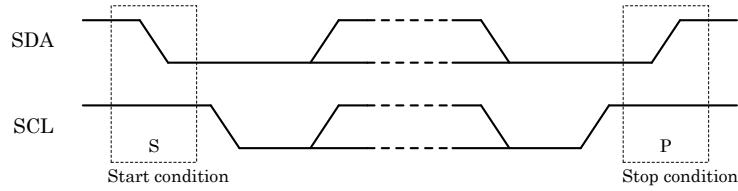

Bit transfer

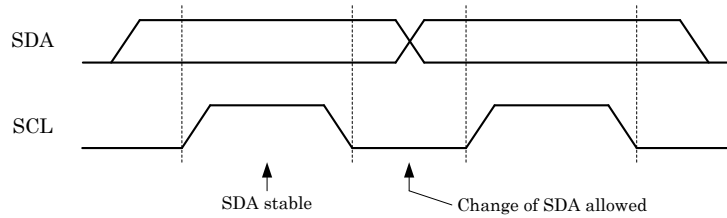

Acknowledge

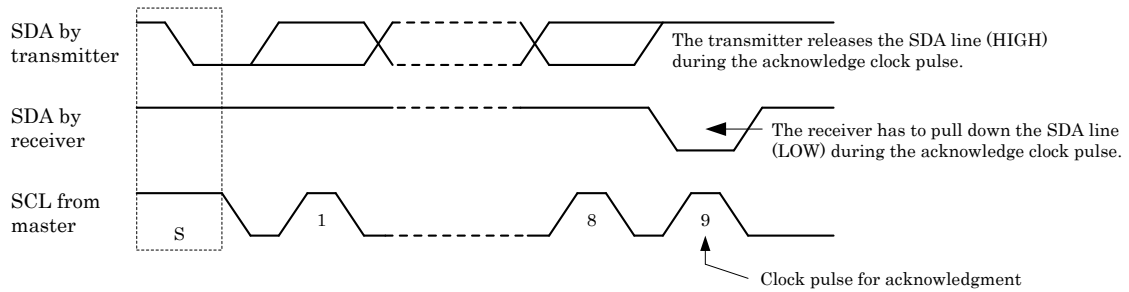

Absolute Maximum Ratings

Characteristics	Symbol	Rating	Unit
Supply voltage	V_{CC}	11	V
Input Pin Voltage	V_{in}	GND - 0.3 to $V_{CC} + 0.3$	V
Power dissipation	P_{DMAX} (Note3)	1250	mW
Operating temperature	T_{opr}	-20~65	°C
Storage temperature	T_{stg}	-55~150	°C

Note3: When using the device at temperatures above $T_a = 25^\circ\text{C}$, reduce the rated power dissipation by 10.0 mW at TC90L01NG per degree of centigrade. (See the diagram below.)

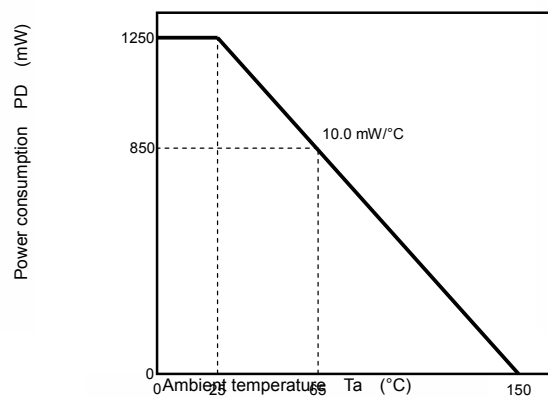

Operating Conditions

Characteristics	Test Condition	Min	Typ.	Max	Unit	Remark
Supply voltage	12	8.1	9.0	9.9	V	—
Composite signal input amplitude	2, 4, 8	—	1.0	—	V _{p-p}	100IRE
Y input amplitude	4, 8	—	1.0	—	V _{p-p}	100IRE
Chroma input amplitude	6	—	286	—	mV _{p-p}	Burst
Audio input amplitude	1, 3, 5, 7, 9, 11	—	—	3.0	V _{p-p}	—

Electrical Characteristics

(referenced to V_{CC} = 9 V at Ta = 25°C unless otherwise specified)

Current Consumption

Pin No.	Pin Name	Symbol	Test Circuit	Min	Typ.	Max	Unit
12	V _{CC}	I _{CC}	—	20	34	48	mA

Pin Voltage

Pin No.	Pin Name	Symbol	Test Circuit	Min	Typ.	Max	Unit
1	TV-L in	V1	—	4.3	4.5	4.7	V
2	TV-V in	V2	—	4.1	4.3	4.5	V
3	TV-R in	V3	—	4.3	4.5	4.7	V
4	V2-V/Y in	V4	—	4.1	4.3	4.5	V
5	V1-L in	V5	—	4.3	4.5	4.7	V
6	V1-C in	V6	—	4.1	4.3	4.5	V
7	V1-R in	V7	—	4.3	4.5	4.7	V
8	V2-V in	V8	—	4.1	4.3	4.5	V
9	V2-L in	V9	—	4.3	4.5	4.7	V
10	ALC	V10	—	—	5.0	—	V
11	V2-R in	V11	—	4.3	4.5	4.7	V
12	V _{CC}	V12	—	—	9.0	—	V
15	GND	V15	—	—	0	—	V
16	TV-R out	V16	—	4.0	4.5	5.0	V
17	TV-L out	V17	—	4.0	4.5	5.0	V
18	Y out	V18	—	4.0	4.3	4.6	V
19	I/O-1	V19	—	—	—	—	V
20	C out	V20	—	4.0	4.3	4.6	V
21	I/O-2	V21	—	—	—	—	V
22	V out	V22	—	4.0	4.3	4.6	V
23	Mon-R out	V23	—	4.2	4.5	4.8	V
24	Mon-L out	V24	—	4.2	4.5	4.8	V

DC Characteristics

Characteristics	Measured Pin	Symbol	Test Circuit	Min.	Typ.	Max.	Unit	Remark
Input pin Input resistance	TV-V in	R2	—	20	30	40	kΩ	Measure a change ΔI in the current flowing into each pin when the voltage is raised by 0.5V. Then calculate the input resistance value R. R = 0.5 V/ΔI [Ω]
	V1-V/Y in	R4	—	20	30	40	kΩ	
	V2-V in	R8	—	20	30	40	kΩ	
	V1-C in	R6	—	20	30	40	kΩ	
	TV-L in	R1	—	80	120	160	kΩ	
	TV-R in	R3	—	80	120	160	kΩ	
	V1-L in	R5	—	80	120	160	kΩ	
	V1-R in	R7	—	80	120	160	kΩ	
	V2-L in	R9	—	80	120	160	kΩ	
	V2-R in	R11	—	80	120	160	kΩ	
Output pin Output resistance	V out	R22	—	30	50	80	Ω	Measure a voltage change ΔV on each pin when a current of 100 μA flows into the pin. Then calculate the output resistance value R. R = ΔV/100 μA [Ω]
	Y out	R18	—	30	50	80	Ω	
	C out	R20	—	30	50	80	Ω	
	TV-L out	R17	—	30	50	80	Ω	
	TV-R out	R16	—	30	50	80	Ω	
	Mon-L out	R24	—	30	50	80	Ω	
	Mon-R out	R23	—	30	50	80	Ω	
S mode discrimination voltage	V1-C in	VthC1	—	2.0	2.5	3.0	V	Voltage on pin 6 at which data B30 changes.
ADC input discrimination voltage	I/O 1	Vth1	—	2.5	3.0	3.5	V	High-Low threshold level of I/O-1 input (pin 19).
	I/O 2	Vth2	—	2.5	3.0	3.5	V	High-Low threshold level of I/O-2 input (pin 21).

AC Characteristics

Characteristics	Select Mode	Symbol	Test Circuit	Min.	Typ.	Max.	Unit	Test Method
V out Input dynamic range	TV-V in	VDR2V1	—	1.5	—	—	V _{p-p}	(1) Apply a 15 kHz sine wave to each input pin. (2) In each select mode, measure an input amplitude at which the output waveform on pin 22 begins to be distorted.
	V1-V/Y in	VDR4V1	—	1.5	—	—	V _{p-p}	
	V2-V in	VDR8V1	—	1.5	—	—	V _{p-p}	
	V2-C in	VDR6V1	—	1.5	—	—	V _{p-p}	
V out Gain	TV-V in	G2V1	—	5.5	6.0	6.5	dB	(1) Apply a 15 kHz, 1.0 V _{p-p} sine wave to each input pin. (2) In each select mode, find the gain between input and output.
	V1-V/Y in	G4V1	—	5.5	6.0	6.5	dB	
	V2-V in	G8V1	—	5.5	6.0	6.5	dB	
	V2-C in	G6V1	—	5.5	6.0	6.5	dB	
V out Frequency response	TV-V in	F2V1	—	15	—	—	MHz	(1) Apply a 1.0 V _{p-p} sine wave to each input pin. (2) In each select mode, measure a frequency at which the output amplitude on pin 22 is 3dB down from the 15 kHz applied level.
	V1-V/Y in	F4V1	—	15	—	—	MHz	
	V2-V in	F8V1	—	15	—	—	MHz	
	V2-C in	F6V1	—	15	—	—	MHz	
V out Crosstalk	TV-V in	CT2V1	—	60	70	—	dB	(1) Apply a 3.58 MHz, 1.0 V _{p-p} sine wave to each input pin. (2) In each select mode, compare signal output from the selected pin with leakage components from nonselected pins to find a crosstalk.
	V1-V/Y in	CT4V1	—	60	70	—	dB	
	V2-V in	CT8V1	—	60	70	—	dB	
	V2-C in	CT6V1	—	60	70	—	dB	

Characteristics	Select Mode	Symbol	Test Circuit	Min.	Typ.	Max.	Unit	Test Method
Y out Input dynamic range	TV-V in	VDR2Y	—	3.0	4.0	—	V _{p-p}	(1) Apply a 15 kHz sine wave to each input pin. (2) In each select mode, measure an input amplitude at which the output waveform on pin 18 begins to be distorted.
	V1-V/Y in	VDR4Y	—	3.0	4.0	—	V _{p-p}	
	V2-V in	VDR8Y	—	3.0	4.0	—	V _{p-p}	
Y out Gain	TV-V in	G2Y	—	-0.5	0	0.5	dB	(1) Apply a 15 kHz, 1.0 V _{p-p} sine wave to each input pin. (2) In each select mode, find the gain between input and output.
	V1-V/Y in	G4Y	—	-0.5	0	0.5	dB	
	V2-V in	G8Y	—	-0.5	0	0.5	dB	
Y out Frequency response	TV-V in	F2Y	—	15	—	—	MHz	(1) Apply a 1.0 V _{p-p} sine wave to each input pin. (2) In each select mode, measure a frequency at which the output amplitude on pin 18 is 3dB down from the 15 kHz applied level.
	V1-V/Y in	F4Y	—	15	—	—	MHz	
	V2-V in	F8Y	—	15	—	—	MHz	
Y out Crosstalk	TV-V in	CT2Y	—	60	70	—	dB	(1) Apply a 3.58 MHz, 1.0 V _{p-p} sine wave to each input pin. (2) In each select mode, compare signal output from the selected pin with leakage components from nonselected pins to find a crosstalk.
	V1-V/Y in	CT4Y	—	60	70	—	dB	
	V2-V in	CT8Y	—	60	70	—	dB	

Characteristics	Select Mode	Symbol	Test Circuit	Min.	Typ.	Max.	Unit	Test Method
C out Input dynamic range	TV-V in	VDR2C	—	1.5	2.0	—	V _{p-p}	(1) Apply a 3.58MHz sine wave to each input pin. (2) In each select mode, measure an input amplitude at which the output waveform on pin 20 begins to be distorted.
	V1-V/Y in	VDR4C	—	1.5	2.0	—	V _{p-p}	
	V2-V in	VDR8C	—	1.5	2.0	—	V _{p-p}	
	V2-C in	VDR6C	—	1.5	2.0	—	V _{p-p}	
C out Gain	TV-V in	G2C	—	-0.5	0	0.5	dB	(1) Apply a 15 kHz, 1.0 V _{p-p} sine wave to each input pin. (2) In each select mode, find the gain between input and output.
	V1-V/Y in	G4C	—	-0.5	0	0.5	dB	
	V2-V in	G8C	—	-0.5	0	0.5	dB	
	V2-C in	G6C	—	-0.5	0	0.5	dB	
C out Frequency response	TV-V in	F2C	—	15	—	—	MHz	(1) Apply a 1.0 V _{p-p} sine wave to each input pin. (2) In each select mode, measure a frequency at which the output amplitude on pin 20 is 3dB down from the 15 kHz applied level.
	V1-V/Y in	F4C	—	15	—	—	MHz	
	V2-V in	F8C	—	15	—	—	MHz	
	V2-C in	F6C	—	15	—	—	MHz	
C out Crosstalk	TV-V in	CT2C	—	60	70	—	dB	(1) Apply a 3.58 MHz, 1.0 V _{p-p} sine wave to each input pin. (2) In each select mode, compare signal output from the selected pin with leakage components from nonselected pins to find a crosstalk.
	V1-V/Y in	CT4C	—	60	70	—	dB	
	V2-V in	CT8C	—	60	70	—	dB	
	V2-C in	CT6C	—	50	55	—	dB	

Characteristics	Select Mode	Symbol	Test Circuit	Min.	Typ.	Max.	Unit	Test Method
TV-L out Input dynamic range	TV-L in	VDR1L1	—	3.0	5.0	—	V _{p-p}	(1) Apply a 1 kHz sine wave to each input pin. (2) In each select mode, measure an input amplitude at which the output waveform on pin 17 begins to be distorted.
	V1-L in	VDR5L1	—	3.0	5.0	—	V _{p-p}	
	V2-L in	VDR9L1	—	3.0	5.0	—	V _{p-p}	
TV-L out Gain	TV-L in	G1L1	—	4.0	6.0	8.0	dB	(1) Apply a 1 kHz, 1.0 V _{p-p} sine wave to each input pin. (2) In each select mode, find the gain between input and output. (3) ALC:Off
	V1-L in	G5L1	—	4.0	6.0	8.0	dB	
	V2-L in	G9L1	—	4.0	6.0	8.0	dB	
TV-L out Output level	TV-L in	VOL1L1	—	1.1	1.6	2.1	V _{p-p}	(1) Apply a 1 kHz, 2.0 V _{p-p} sine wave to each input pin. Vol:7F (2) In each select mode, measure an output amplitude at pin 17. (3) ALC:"1.6Vp-p"
	V1-L in	VOL5L1	—	1.1	1.6	2.1	V _{p-p}	
	V2-L in	VOL9L1	—	1.1	1.6	2.1	V _{p-p}	
TV-L out ALC level Min. ALC level Max.	*	GANL1	—	-4.0	-3.0	-2.0	dB	(1) Set ALC level "1.1Vpp" and measure output level changes. Vol:7F (2) Set ALC level "2.3Vpp" and measure output level changes. Vol:7F
	*	GAXL1	—	2.0	3.0	4.0	dB	
TV-L out Frequency response	TV-L in	F1L1	—	0.1	—	—	MHz	(1) Apply a 1.0 V _{p-p} sine wave to each input pin. (2) In each select mode, measure a frequency at which the output amplitude on pin 17 is 3dB down from the 1 kHz applied level.
	V1-L in	F5L1	—	0.1	—	—	MHz	
	V2-L in	F9L1	—	0.1	—	—	MHz	
TV-L out	TV-L in	CT1L1	—	70	80	—	dB	(1) Apply a 1 kHz, 1.0 V _{p-p} sine wave to each input pin. (2) In each select

Characteristics	Select Mode	Symbol	Test Circuit	Min.	Typ.	Max.	Unit	Test Method
Crosstalk	V1-L in	CT5L1	—	70	80	—	dB	mode, compare signal output from the selected pin with leakage components from nonselected pins to find a crosstalk.
	V2-L in	CT9L1	—	70	80	—	dB	
TV-L out Mute attenuation	TV-L in	M1L1	—	70	90	—	dB	(1) Apply a 1 kHz, 1.0 V _{pp} sine wave to each input pin. (2) In each select mode, compare the output amplitudes on pin 17 when mute is turned on and turned off to find mute attenuation.
	V1-L in	M5L1	—	70	90	—	dB	
	V2-L in	M9L1	—	70	90	—	dB	

Characteristics	Select Mode	Symbol	Test Circuit	Min.	Typ.	Max.	Unit	Test Method
TV-R out Input dynamic range	TV-R in	VDR3R1	—	3.0	5.0	—	V _{p-p}	(1) Apply a 1 kHz sine wave to each input pin. (2) In each select mode, measure an input amplitude at which the output waveform on pin 16 begins to be distorted.
	V1-R in	VDR7R1	—	3.0	5.0	—	V _{p-p}	
	V2-R in	VDR11R1	—	3.0	5.0	—	V _{p-p}	
TV-R out Gain	TV-R in	G3R1	—	4.0	6.0	8.0	dB	(1) Apply a 1 kHz, 1.0 V _{p-p} sine wave to each input pin. (2) In each select mode, find the gain between input and output. (3) ALC:Off
	V1-R in	G7R1	—	4.0	6.0	8.0	dB	
	V2-R in	G11R1	—	4.0	6.0	8.0	dB	
TV-R out Output level	TV-R in	VOL3R1	—	1.1	1.6	2.1	V _{p-p}	(1) Apply a 1 kHz, 2.0 V _{p-p} sine wave to each input pin. Vol:7F (2) In each select mode, measure an output amplitude at pin 16. (3) ALC:"1.6Vp-p"
	V1-R in	VOL7R1	—	1.1	1.6	2.1	V _{p-p}	
	V2-R in	VOL11R1	—	1.1	1.6	2.1	V _{p-p}	
TV-R out ALC level Min. ALC level Max.	*	GANR1	—	-4.0	-3.0	-2.0	dB	(1) Set ALC level "1.1Vpp" and measure output level changes. Vol:7F (2) Set ALC level "2.3Vpp" and measure output level changes. Vol:7F
	*	GAXR1	—	2.0	3.0	4.0	dB	
TV-R out Frequency response	TV-R in	F3R1	—	0.1	—	—	MHz	(1) Apply a 1.0 V _{p-p} sine wave to each input pin. (2) In each select mode, measure a frequency at which the output amplitude on pin 16 is 3dB down from the 1 kHz applied level.
	V1-R in	F7R1	—	0.1	—	—	MHz	
	V2-R in	F11R1	—	0.1	—	—	MHz	
TV-R out Crosstalk	TV-R in	CT3R1	—	70	80	—	dB	(1) Apply a 1 kHz, 1.0 V _{p-p} sine wave to each input pin. (2) In each select

Characteristics	Select Mode	Symbol	Test Circuit	Min.	Typ.	Max.	Unit	Test Method
	V1-R in	CT7R1	—	70	80	—	dB	mode, compare signal output from the selected pin with leakage components from nonselected pins to find a crosstalk.
	V2-R in	CT11R1	—	70	80	—	dB	
TV-R out Mute attenuation	TV-R in	M3R1	—	70	90	—	dB	(1) Apply a 1 kHz, 1.0 V _{p-p} sine wave to each input pin. (2) In each select mode, compare the output amplitudes on pin 16 when mute is turned on and turned off to find mute attenuation.
	V1-R in	M7R1	—	70	90	—	dB	
	V2-R in	M11R1	—	70	90	—	dB	

Characteristics	Select Mode	Symbol	Test Circuit	Min.	Typ.	Max.	Unit	Test Method
Mon-L out Input dynamic range	TV-L in	VDR1L2	—	3.5	5.0	—	V _{p-p}	(1) Apply a 1 kHz sine wave to each input pin. (2) In each select mode, measure an input amplitude at which the output waveform on pin 24 begins to be distorted.
	V1-L in	VDR5L2	—	3.5	5.0	—	V _{p-p}	
	V2-L in	VDR9L2	—	3.5	5.0	—	V _{p-p}	
Mon-L out Gain	TV-L in	G1L2	—	-0.5	0	0.5	dB	(1) Apply a 1 kHz, 1.0 V _{p-p} sine wave to each input pin. (2) In each select mode, find the gain between input and output.
	V1-L in	G5L2	—	-0.5	0	0.5	dB	
	V2-L in	G9L2	—	-0.5	0	0.5	dB	
Mon-L out Frequency response	TV-L in	F1L2	—	0.1	—	—	MHz	(1) Apply a 1.0 V _{p-p} sine wave to each input pin. (2) In each select mode, measure a frequency at which the output amplitude on pin 24 is 3dB down from the 1 kHz applied level.
	V1-L in	F5L2	—	0.1	—	—	MHz	
	V2-L in	F9L2	—	0.1	—	—	MHz	
Mon-L out Crosstalk	TV-L in	CT1L2	—	70	90	—	dB	(1) Apply a 1 kHz, 1.0 V _{p-p} sine wave to each input pin. (2) In each select mode, compare signal output from the selected pin with leakage components from nonselected pins to find a crosstalk.
	V1-L in	CT5L2	—	70	90	—	dB	
	V2-L in	CT9L2	—	70	90	—	dB	
Mon-L out Mute attenuation	TV-L in	M1L2	—	70	80	—	dB	(1) Apply a 1 kHz, 1.0 V _{p-p} sine wave to each input pin. (2) In each select mode, compare the output amplitudes on pin 24 when mute is turned on and turned off to find mute attenuation.
	V1-L in	M5L2	—	70	80	—	dB	
	V2-L in	M9L2	—	70	80	—	dB	

Characteristics	Select Mode	Symbol	Test Circuit	Min.	Typ.	Max.	Unit	Test Method
Mon-R out Input dynamic range	TV-R in	VDR3R2	—	3.5	5.0	—	V _{p-p}	(1) Apply a 1 kHz sine wave to each input pin. (2) In each select mode, measure an input amplitude at which the output waveform on pin 23 begins to be distorted.
	V1-R in	VDR7R2	—	3.5	5.0	—	V _{p-p}	
	V2-R in	VDR11R2	—	3.5	5.0	—	V _{p-p}	
Mon-R out Gain	TV-R in	G3R2	—	-0.5	0	0.5	dB	(1) Apply a 1 kHz, 1.0 V _{p-p} sine wave to each input pin. (2) In each select mode, find the gain between input and output.
	V1-R in	G7R2	—	-0.5	0	0.5	dB	
	V2-R in	G11R2	—	-0.5	0	0.5	dB	
Mon-R out Frequency response	TV-R in	F3R2	—	0.1	—	—	MHz	(1) Apply a 1.0 V _{p-p} sine wave to each input pin. (2) In each select mode, measure a frequency at which the output amplitude on pin 23 is 3dB down from the 1 kHz applied level.
	V1-R in	F7R2	—	0.1	—	—	MHz	
	V2-R in	F11R2	—	0.1	—	—	MHz	
Mon-R out Crosstalk	TV-R in	CT3R2	—	70	90	—	dB	(1) Apply a 1 kHz, 1.0 V _{p-p} sine wave to each input pin. (2) In each select mode, compare signal output from the selected pin with leakage components from nonselected pins to find a crosstalk.
	V1-R in	CT7R2	—	70	90	—	dB	
	V2-R in	CT11R2	—	70	90	—	dB	
Mon-R out Mute attenuation	TV-R in	M3R2	—	70	80	—	dB	(1) Apply a 1 kHz, 1.0 V _{p-p} sine wave to each input pin. (2) In each select mode, compare the output amplitudes on pin 23 when mute is turned on and turned off to find mute attenuation.
	V1-R in	M7R2	—	70	80	—	dB	
	V2-R in	M11R2	—	70	80	—	dB	

Reference data

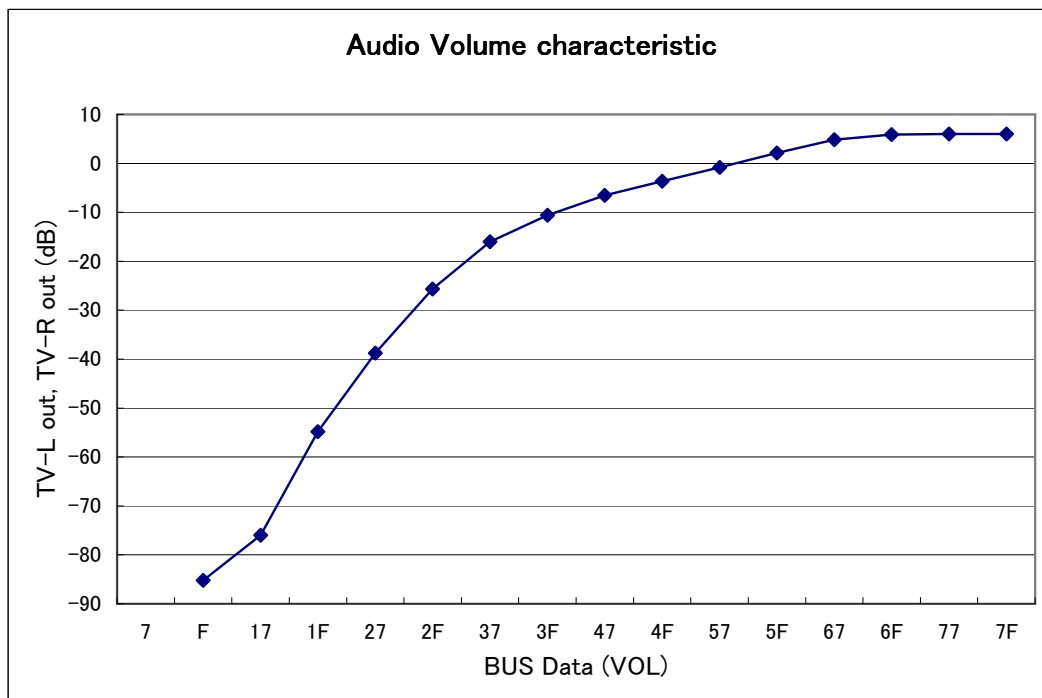
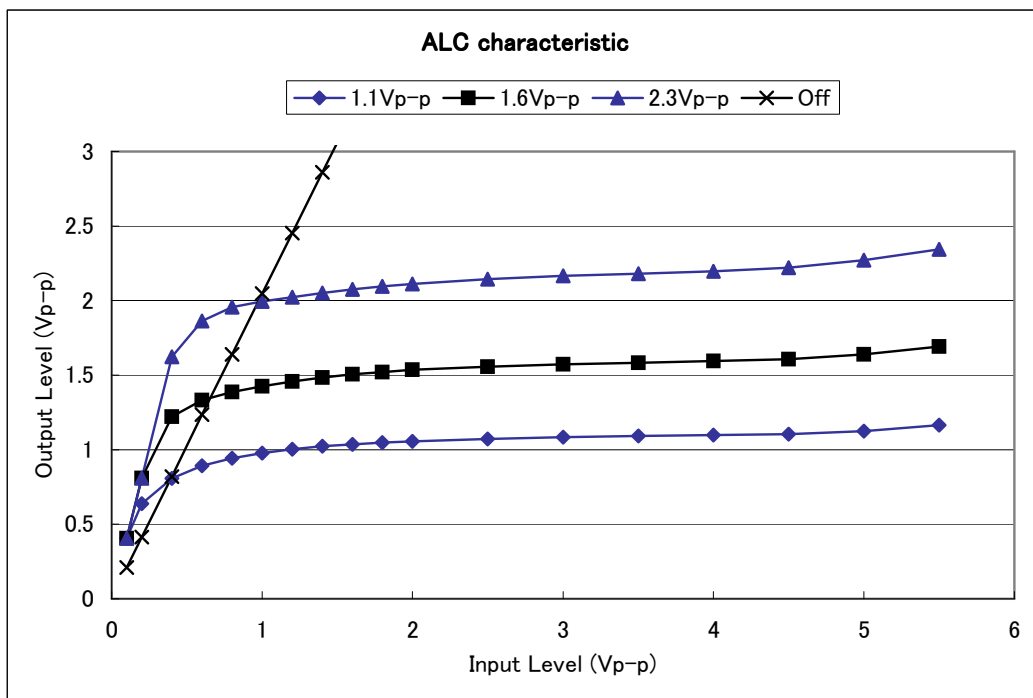

Application Circuit

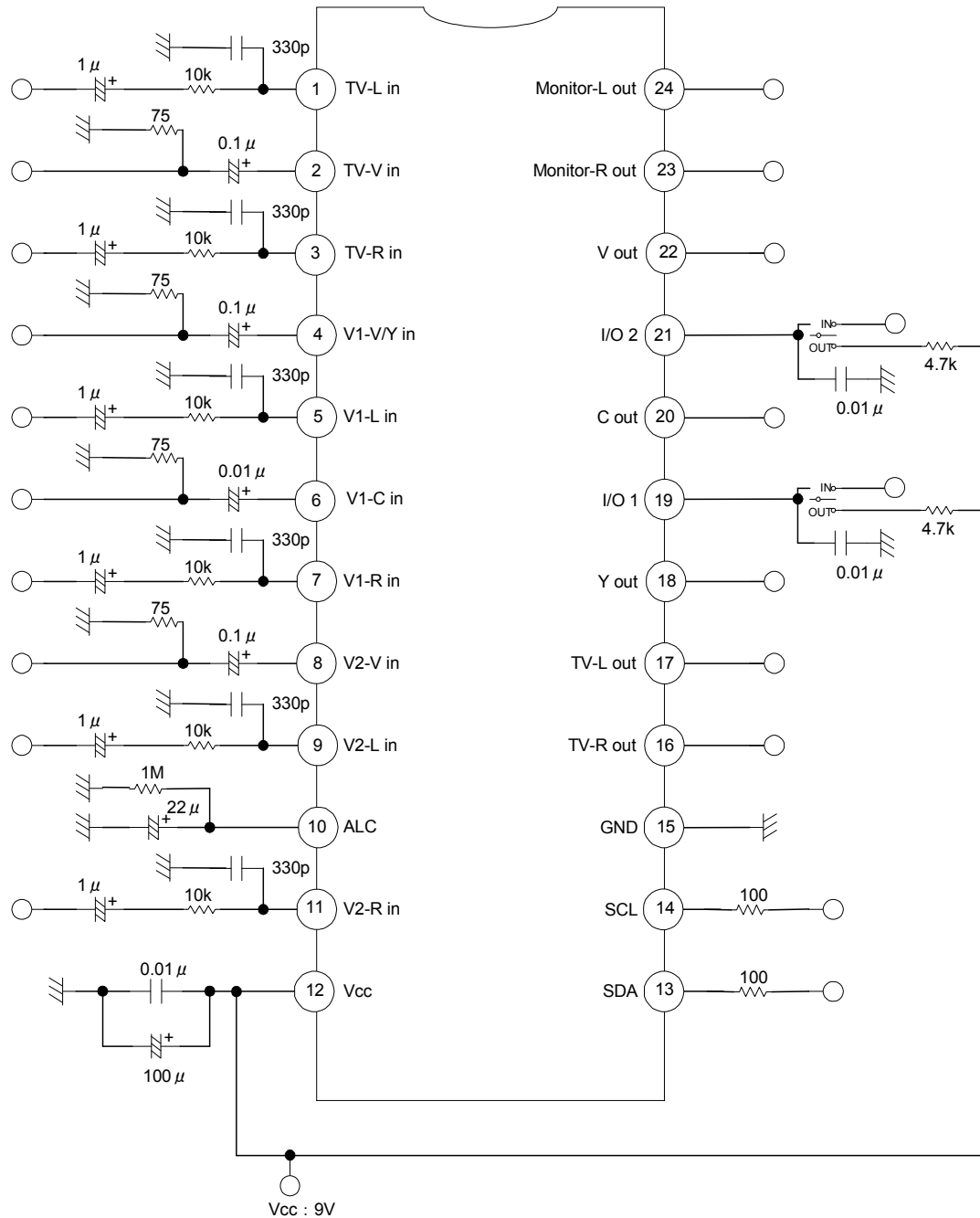

Test Circuit

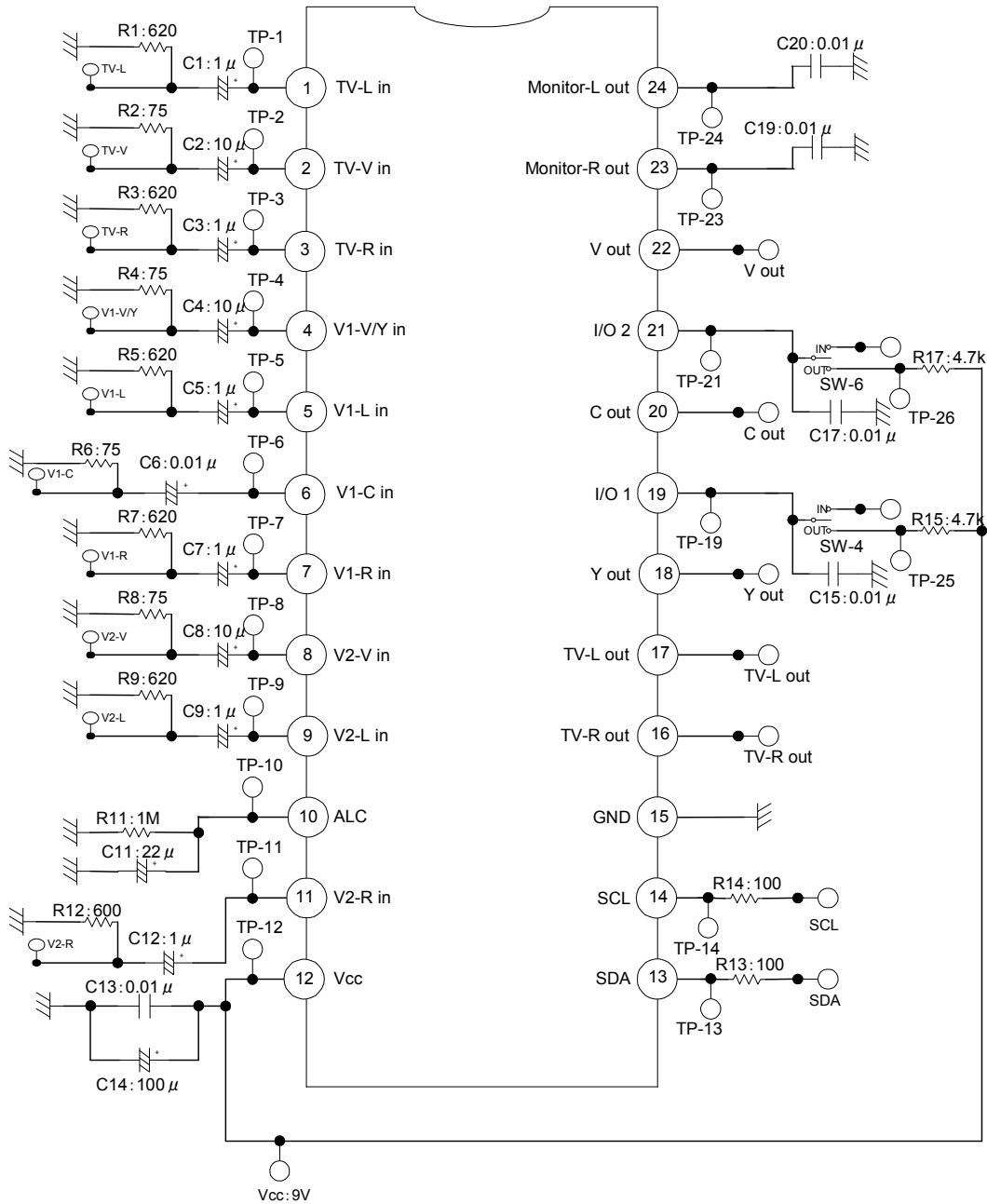

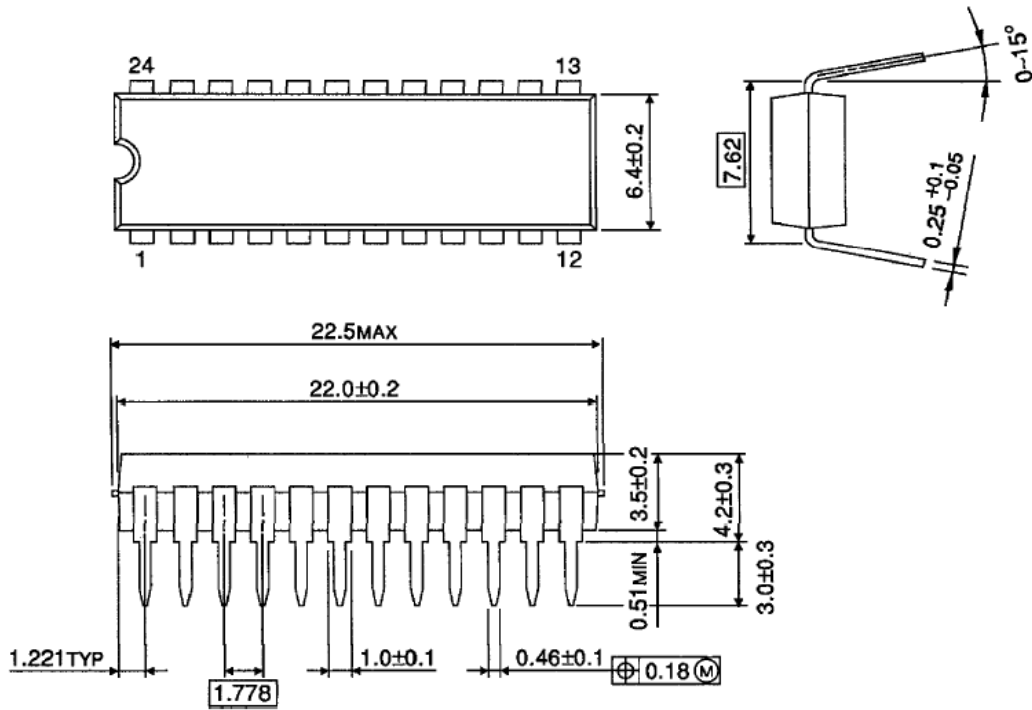
Package Dimensions

Weight: 1.22 g (typ.)

About solderability, following conditions were confirmed.

• Solderability

- (1) Use of Sn-37Pb solder Bath
 - solder bath temperature = 230°C
 - dipping time = 5 seconds
 - the number of times = once
 - use of R-type flux
- (2) Use of Sn-3.0Ag-0.5Cu solder
 - solder bath temperature = 245°C
 - dipping time = 5 seconds
 - the number of times = once

RESTRICTIONS ON PRODUCT USE

030619EBA

The information contained herein is subject to change without notice.

The information contained herein is presented only as a guide for the applications of our products. No responsibility is assumed by TOSHIBA for any infringements of patents or other rights of the third parties which may result from its use. No license is granted by implication or otherwise under any patent or patent rights of TOSHIBA or others.

TOSHIBA is continually working to improve the quality and reliability of its products. Nevertheless, semiconductor devices in general can malfunction or fail due to their inherent electrical sensitivity and vulnerability to physical stress. It is the responsibility of the buyer, when utilizing TOSHIBA products, to comply with the standards of safety in making a safe design for the entire system, and to avoid situations in which a malfunction or failure of such TOSHIBA products could cause loss of human life, bodily injury or damage to property.

In developing your designs, please ensure that TOSHIBA products are used within specified operating ranges as set forth in the most recent TOSHIBA products specifications. Also, please keep in mind the precautions and conditions set forth in the "Handling Guide for Semiconductor Devices," or "TOSHIBA Semiconductor Reliability Handbook" etc..

The TOSHIBA products listed in this document are intended for usage in general electronics applications (computer, personal equipment, office equipment, measuring equipment, industrial robotics, domestic appliances, etc.). These TOSHIBA products are neither intended nor warranted for usage in equipment that requires extraordinarily high quality and/or reliability or a malfunction or failure of which may cause loss of human life or bodily injury ("Unintended Usage"). Unintended Usage include atomic energy control instruments, airplane or spaceship instruments, transportation instruments, traffic signal instruments, combustion control instruments, medical instruments, all types of safety devices, etc.. Unintended Usage of TOSHIBA products listed in this document shall be made at the customer's own risk.

The products described in this document are subject to the foreign exchange and foreign trade laws.

TOSHIBA products should not be embedded to the downstream products which are prohibited to be produced and sold, under any law and regulations.