



PA6021

CMOS IC

2-W STEREO AUDIO POWER AMPLIFIER WITH ADVANCED DC VOLUME CONTROL

DESCRIPTION

The **PA6021** is a stereo audio power amplifier that drives 2 W/channel of continuous RMS power into a 4-Ω load when utilizing a heat sink. Advanced dc volume control minimizes external components and allows BTL (speaker) volume control and SE (headphone) volume control.

The 20-pin DIP package allows for the use of a heatsink which provides higher output power.

To ensure a smooth transition between active and shutdown modes, a fade mode ramps the volume up and down.

FEATURES

- * 2 W Into 4-W speakers with external heatsink
- * DC volume control with 2-dB Steps from -40 dB ~ 20 dB
 - Fade Mode
 - -85-dB Mute Mode
- * Differential Inputs
- * 1-μA Shutdown Current (Typical)
- * Headphone Mode

ORDERING INFORMATION

Ordering Number			Package	Packing
Normal	Lead Free Plating	Halogen Free		
PA6021-D20-T	PA6021L-D20-T	PA6021G-D20-T	DIP-20	Tube

<p>PA6021L-D20-T</p>	<p>(1) Packing Type (2) Package Type (3) Lead Plating</p>	<p>(1) T: Tube (2) D20: DIP-20 (3) G: Halogen Free, L: Lead Free, Blank: Pb/Sn</p>
----------------------	---	--

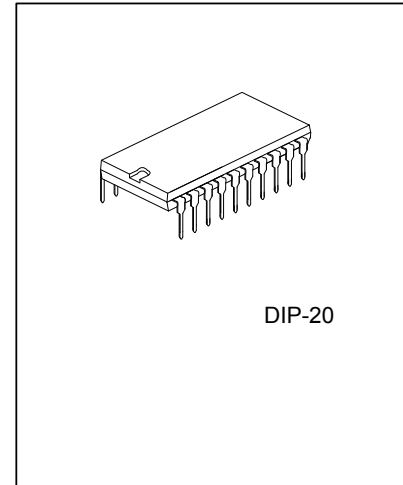

Lead-free: PA6021L
Halogen-free: PA6021G

■ PIN CONFIGURATION

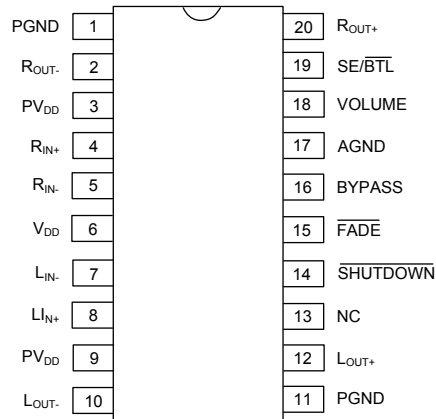

■ PIN DESCRIPTION

PIN #	PIN NAME	I/O	DESCRIPTION
16	BYPASS	I	Tap to voltage divider for internal midsupply bias generator used for analog reference
15	$\overline{\text{FADE}}$	I	Places the amplifier in fade mode if a logic low is placed on this terminal; normal operation if logic high is placed on this terminal.
17	AGND		Analog power supply ground
7	L _{IN-}	I	Left channel negative input for fully differential input.
8	L _{IN+}	I	Left channel positive input for fully differential input.
10	L _{OUT-}	O	Left channel negative audio output
12	L _{OUT+}	O	Left channel positive audio output.
13	NC		No connection
1,11	PGND		Power ground
3,9	PV _{DD}		Supply voltage terminal for power stage
5	R _{IN-}	I	Right channel negative input for fully differential input.
4	R _{IN+}	I	Right channel positive input for fully differential input.
2	R _{OUT-}	O	Right channel negative audio output
20	R _{OUT+}	O	Right channel positive audio output
19	SE/ $\overline{\text{BTL}}$	I	Output control. When this terminal is high, SE outputs are selected. When this terminal is low, BTL outputs are selected.
14	$\overline{\text{SHUTDOWN}}$	I	Places the amplifier in shutdown mode if a TTL logic low is placed on this terminal
6	V _{DD}		Supply voltage terminal
18	VOLUME	I	Terminal for dc volume control. DC voltage range is 0 to V _{DD} .

■ ABSOLUTE MAXIMUM RATING

PARAMETER	SYMBOL	RATINGS	UNIT
Supply Voltage, V_{DD} , PV_{DD}	V_{SS}	-0.3V ~ 6V	V
Input Voltage, R_{IN+} , R_{IN-} , L_{IN+} , L_{IN-}	V_{IN}	-0.3V ~ $V_{DD}+0.3V$	V
Junction Temperature	T_J	-40°C ~ 150°C	°C
Operating Temperature	T_{OPR}	-40°C ~ 85°C	°C
Storage Temperature Range	T_{STG}	-65°C ~ 85°C	°C

Note: Absolute maximum ratings are those values beyond which the device could be permanently damaged.

Absolute maximum ratings are stress ratings only and functional device operation is not implied.

■ ELECTRICAL CHARACTERISTICS ($T_a=25^\circ\text{C}$, unless otherwise specified)

PARAMETER	SYMBOL	CONDITIONS	MIN	TYP	MAX	UNIT
DC CHARACTERISTICS ($V_{DD}=PV_{DD}=5.5V$)						
Supply Voltage, V_{DD} , PV_{DD}	V_{DD}		4		5.5	V
DC Differential Output Voltage	$V_{OUT(DIFF)}$	Gain=0dB, SE/ \overline{BTL} =0V			30	mV
		Gain=20dB, SE/ \overline{BTL} =0V			50	
High-level Input Voltage	V_{IH}	SE/ \overline{BTL} , \overline{FADE}	$0.8xV_{DD}$			V
		SHUTDOWN	2			V
Low-level Input Voltage	V_{IL}	SE/ \overline{BTL} , \overline{FADE}			$0.6xV_{DD}$	V
		SHUTDOWN			0.8	V
High-level Input Current (SE/ \overline{BTL} , \overline{FADE} , SHUTDOWN, VOLUME)	$ I_{IH} $	$V_{IN}=V_{DD}=PV_{DD}$			1	μA
Low-level Input Current (SE/ \overline{BTL} , \overline{FADE} , SHUTDOWN, VOLUME)	$ I_{IL} $	$V_{IN}=0V$			1	μA
Supply Current, No Load	I_{DD}	SE/ \overline{BTL} =0V, SHUTDOWN=2V	6.0	7.5	9.0	mA
		SE/ \overline{BTL} =5.5V, SHUTDOWN=2V	3.0	5	6	
Supply Current, Shutdown Mode	$I_{DD(SD)}$	SHUTDOWN=0V		1	20	μA
AC CHARACTERISTICS ($V_{DD}=PV_{DD}=5V$, $R_L=4\Omega$, Gain=20dB)						
Bypass Voltage (Nominally $V_{DD}/2$)	$V_{(Bypass)}$	Measured at pin 16, No load, $V_{DD}=5.5V$	2.65	2.75	2.85	V
High-Level Output Voltage	V_{OH}	$R_L=8\Omega$, Measured between output and $V_{DD}=5.5V$			700	mV
Low-Level Output Voltage	V_{OL}	$R_L=8\Omega$, Measured between output and GND, $V_{DD}=5.5V$			400	mV
Output Power	P_{OUT}	THD=1%, f=1kHz		1.5		W
		THD=10%, f=1kHz		2		
Total Harmonic Distortion + Noise	THD+N	$P_{OUT}=1W$, $R_L=8\Omega$, f=20Hz~20kHz		<0.8%		
Power Supply Rejection Ratio	PSRR	$V_{DD}=PV_{DD}=4V\sim 5.5V$	-42	-70		dB
Input Impedance	Z_I	VOLUME=5V		14		k Ω
Supply Ripple Rejection Ratio	RR	f=1kHz, Gain=0dB, $C_{(BYP)}=0.47\mu\text{F}$	BTL		-82	dB
			SE		-57	dB
Noise Output Voltage	eN	f=20Hz~20kHz, Gain=0dB, $C_{(BYP)}=0.47\mu\text{F}$		36		μV_{RMS}
Supply Current, Max Power Into a 4- Ω Load	I_{DD}	SHUTDOWN=2V, $R_L=4\Omega$, SE/ \overline{BTL} =0V, $P_{OUT}=2W$		1.3		A_{RMS}

■ TYPICAL APPLICATION CIRCUIT

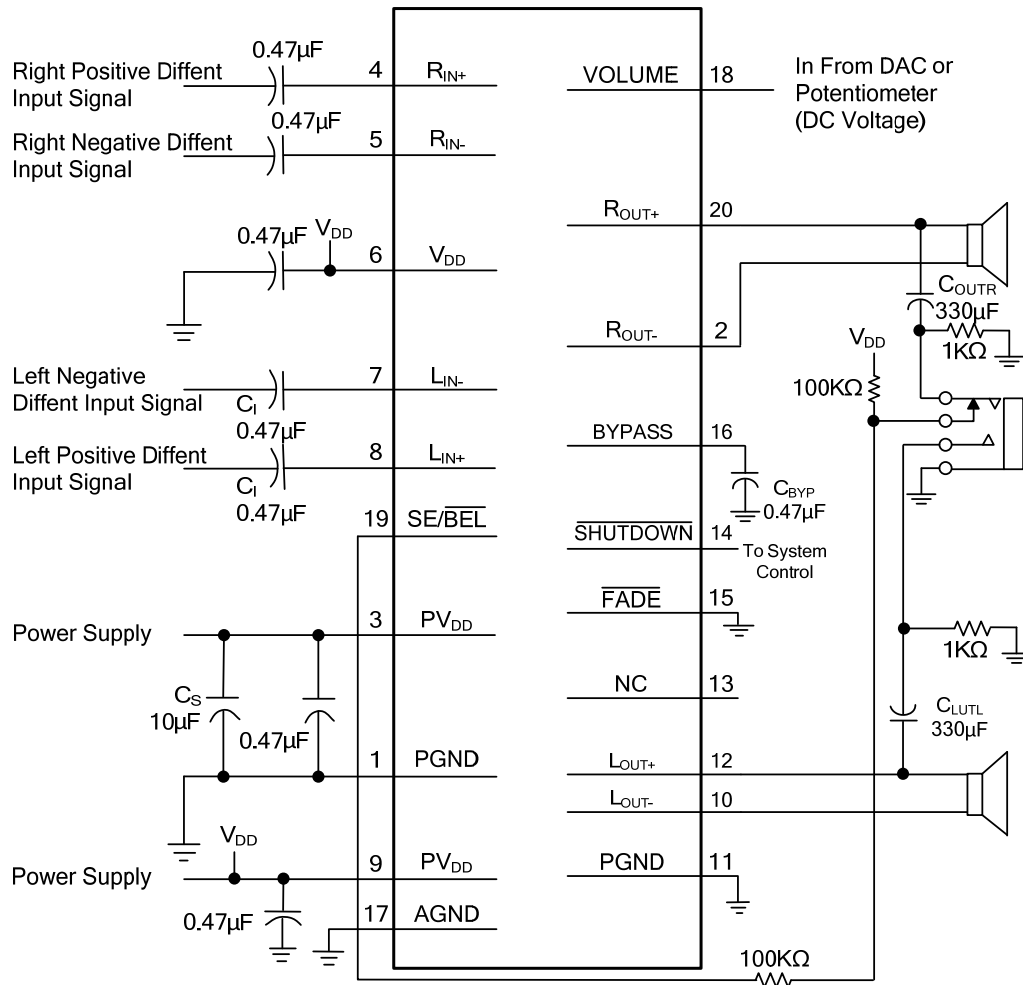

■ BLOCK DIAGRAM

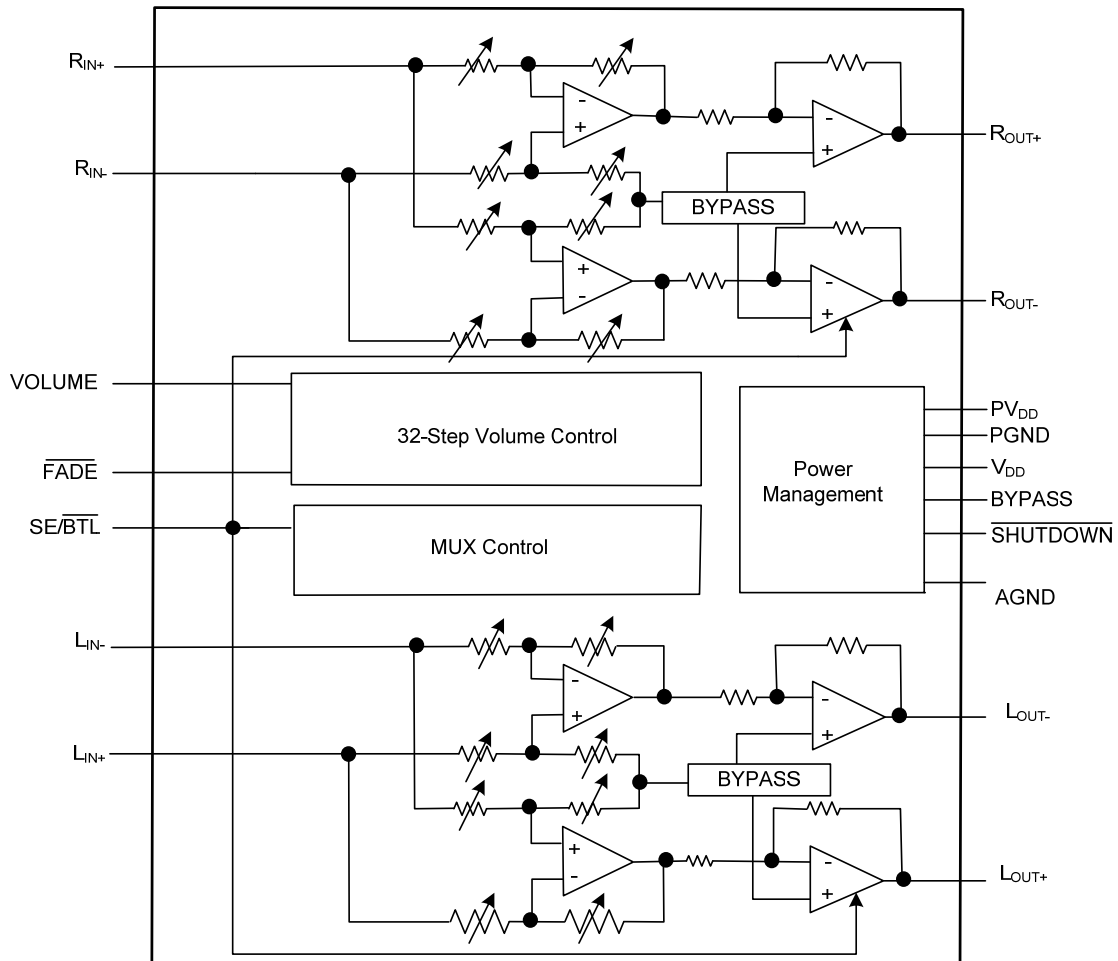

■ TYPICAL CHARACTERISTICS

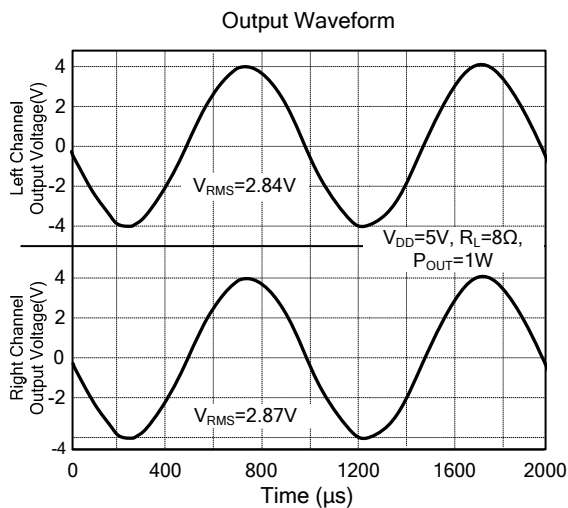
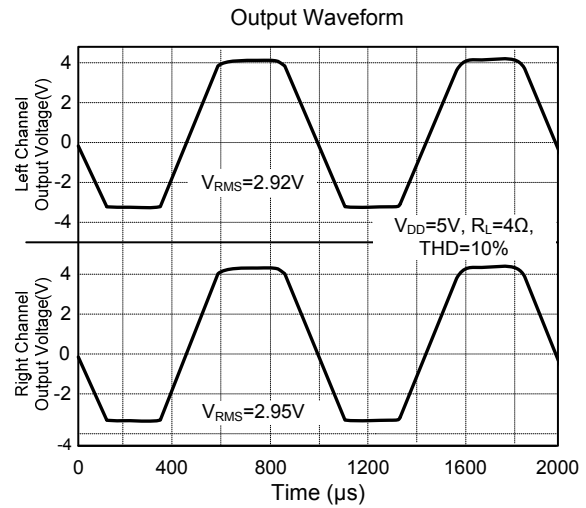
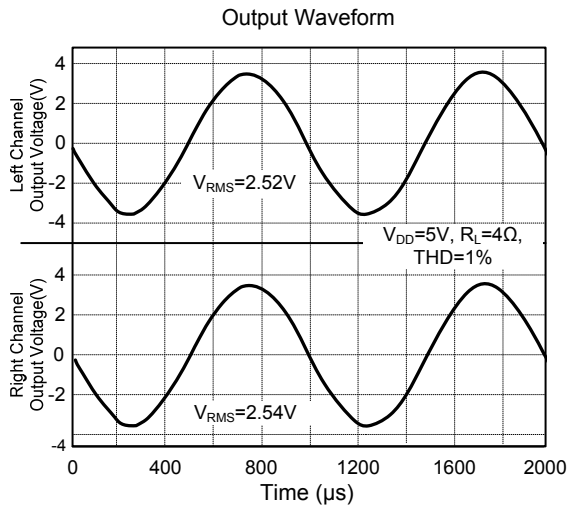

UTC assumes no responsibility for equipment failures that result from using products at values that exceed, even momentarily, rated values (such as maximum ratings, operating condition ranges, or other parameters) listed in products specifications of any and all UTC products described or contained herein. UTC products are not designed for use in life support appliances, devices or systems where malfunction of these products can be reasonably expected to result in personal injury. Reproduction in whole or in part is prohibited without the prior written consent of the copyright owner. The information presented in this document does not form part of any quotation or contract, is believed to be accurate and reliable and may be changed without notice.