

1.5MHz, 800mA, High Efficiency Synchronous

PWM Step-Down DC/DC Convert

General Description

The LP3204 is a constant frequency, current mode, PWM step-down converter. The device integrates a main switch and a synchronous rectifier for high efficiency. The 2.5V to 5.5V input voltage range makes the LP3204 is ideally suited for portable electronic devices that are powered from 1-cell Li-ion battery or from other power sources within the range such as cellular phones, PDAs and handy-terminals.

Internal synchronous rectifier with low RDS(ON) dramatically reduces conduction loss at PWM mode. The internal synchronous switch increases efficiency while eliminate the need for an external Schottky diode. The switching ripple is easily smoothed-out by small package filtering elements due to a fixed operation frequency of 1.5MHz. This along with small SOT-23-5 package provide small PCB area application. Other features include soft start, lower internal reference voltage with 2% accuracy, over temperature protection, and over current protection.

Ordering Information

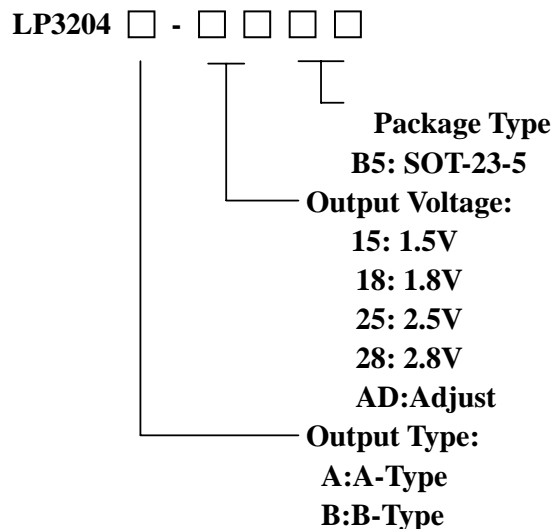

Features

- ◆ High Efficiency: 96%
- ◆ 1.5MHz Fixed-Frequency PWM Operation
- ◆ Adjustable Output From 0.6V to VIN
- ◆ 800mA Output Current, 1.1A Peak Current
- ◆ No Schottky Diode Required
- ◆ 100% Duty Cycle Low Dropout Operation
- ◆ Available in SOT23-5 Package
- ◆ Short Circuit and Thermal Protection
- ◆ Over Voltage Protection
- ◆ Low than 1µA Shutdown Current

Applications

- ✧ Portable Media Players/MP3 players
- ✧ Cellular and Smart mobile phone
- ✧ PDA
- ✧ DSC
- ✧ Wireless Card

Pin Configurations

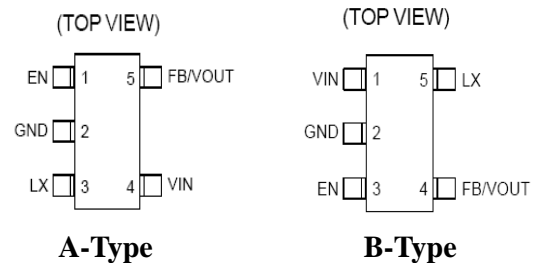

Marking Information

RoHS compliant and compatible with the current requirements of IPC/JEDEC J-STD-0202. Suitable for use in SnPb or Pb-free soldering processes.

Functional Pin Description

Pin Number	Pin Name	Pin Function
1	EN	Chip Enable (Active High).
2	GND	Ground.
3	LX	Pin for Switching.
4	VIN	Power Input.
5	FB/VOUT	Feedback Input Pin.

Function Block Diagram

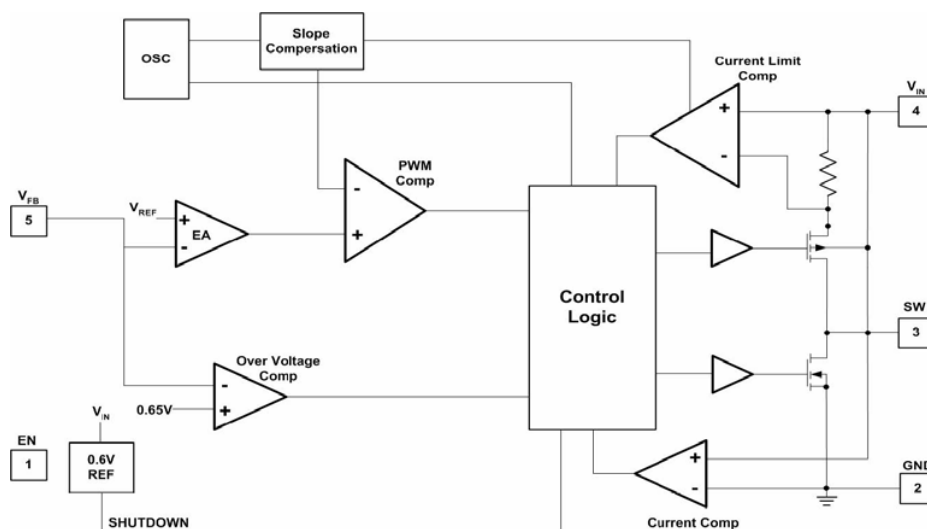

Absolute Maximum Ratings

- Input Supply Voltage ----- -0.3V to 6V
- EN, VFB Voltages ----- -0.3V to V_{IN}
- P-Channel Switch Source Current (DC) ----- 800mA
- N-Channel Switch Sink Current (DC) ----- 800mA
- Peak SW Sink and Source Current ----- 1.4A
- Operating Temperature Range ----- -40°C to 85°C
- Junction Temperature ----- 125°C
- Storage Temperature ----- -65°C to 150°C
- Lead Temp (Soldering, 10sec) ----- 260°C
- ESD Rating (HBM) ----- 2kV

Electrical Characteristics

(VIN = 3.6V, VOUT = 2.5V, VREF = 0.6V, L = 2.2μH, CIN= 4.7μF, COUT= 10μF, TA= 25°C, IMAX = 650mA unless otherwise specified)

Parameter	Symbol	Test Conditions	Min	Typ	Max	Units
Input Voltage Range	VIN		2.5		6	V
Quiescent Current	IQ	IOUT = 0mA, VFB = VREF + 5%		270	370	μA
Shutdown Current	ISHDN	EN = GND		0.1	1	μA
Reference Voltage	VREF	For adjustable output voltage	0.588	0.6	0.612	V
Adjustable Output Range	VOUT		VREF		VIN - 0.2	V
	Δ VOUT	VIN = 2.2 to 5.5V, VOUT = 1.0V 0A < IOUT < 600mA	-3		+3	%
	Δ VOUT	VIN = 2.2 to 5.5V, VOUT = 1.2V 0A < IOUT < 600mA	-3		+3	%
	Fix Δ VOUT	VIN = 2.2 to 5.5V, VOUT = 1.5V 0A < IOUT < 600mA	-3		+3	%
Output Voltage Accuracy	Δ VOUT	VIN = 2.2 to 5.5V, VOUT = 1.8V 0A < IOUT < 600mA	-3		+3	%
		VIN = 2.8 to 5.5V, VOUT = 2.5V 0A < IOUT < 600mA	-3		+3	%
		VIN = 3.5 to 5.5V, VOUT = 3.3V 0A < IOUT < 600mA	-3		+3	%
	Adjustable Δ VOUT	VIN = VOUT + 0.2V to 5.5V, VIN ≧ 3.5V 0A < IOUT < 600mA	-3		+3	%
		VIN = VOUT + 0.4V to 5.5V, VIN ≧ 2.2V 0A < IOUT < 600mA	-3		+3	%
FB Input Current	IFB	VFB = VIN	-30		30	nA
PMOSFET RON	PRDS(ON)	IOUT = 200mA VIN = 3.6V		0.16	0.26	Ω
NMOSFET RON	NRDS(ON)	IOUT = 200mA VIN = 3.6V		0.19		Ω
P-Channel Current Limit	IP(LM)	VIN = 2.2 to 5.5 V	1	1.2	1.4	
EN Threshold	VEN		0.3	1.0	1.5	V
EN Leakage Current	VENL		--	1		uA

Typical Operating Characteristics

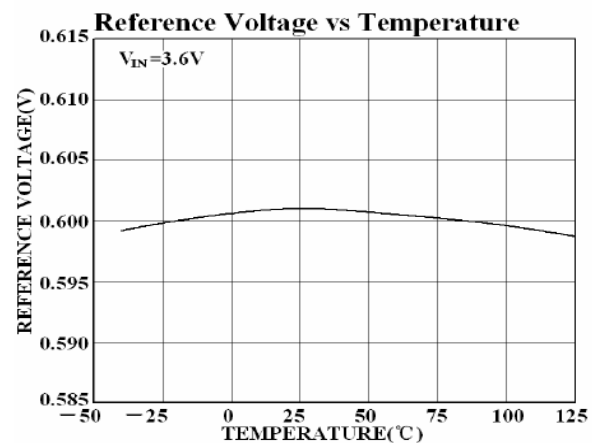
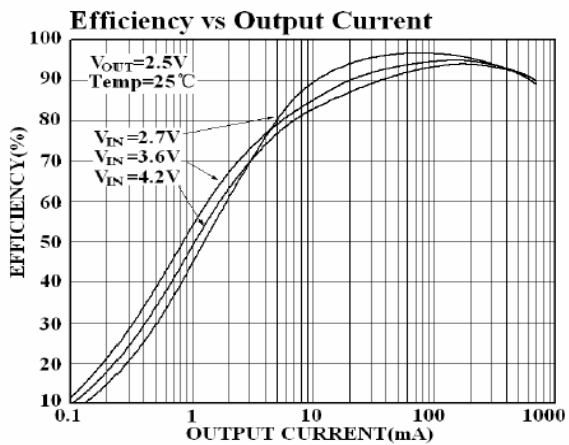
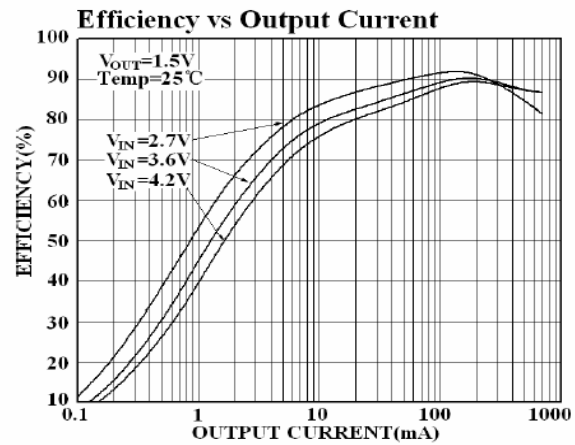
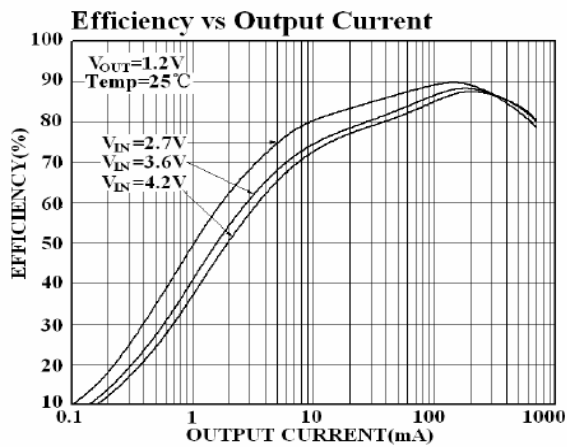
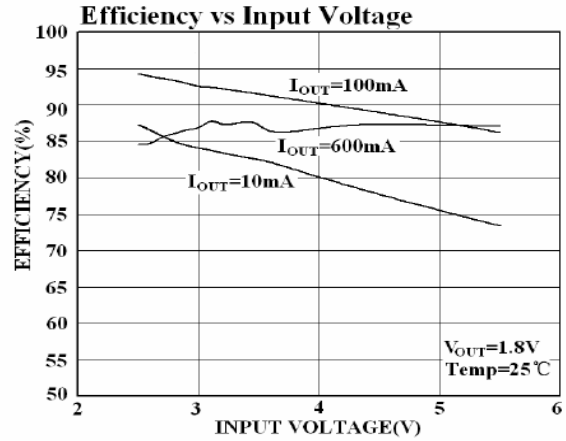
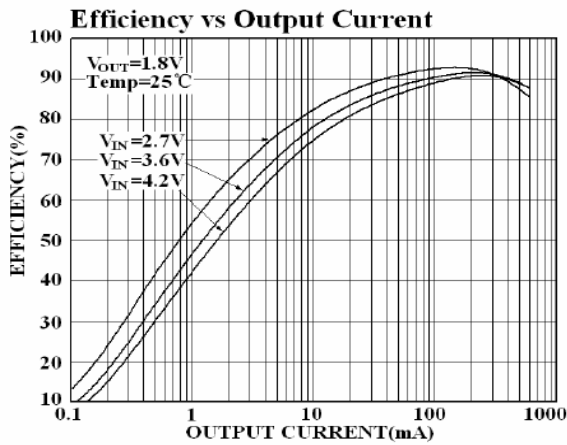

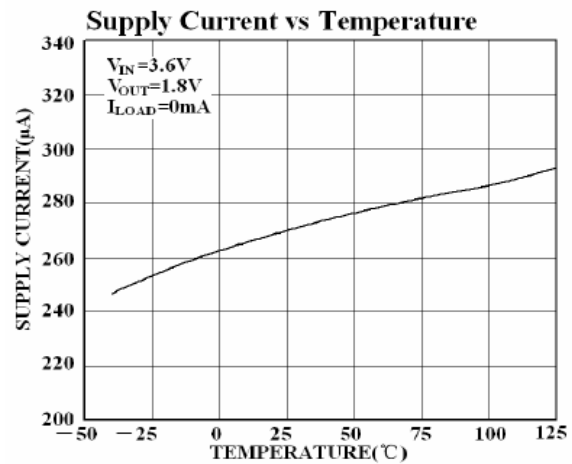
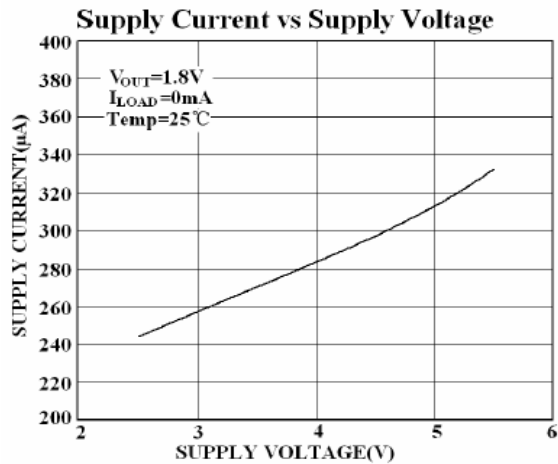
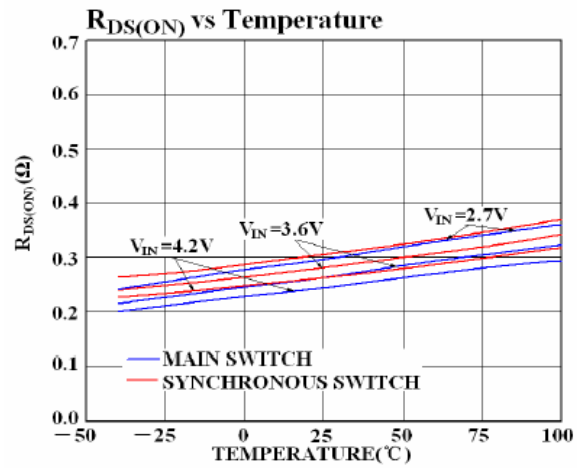
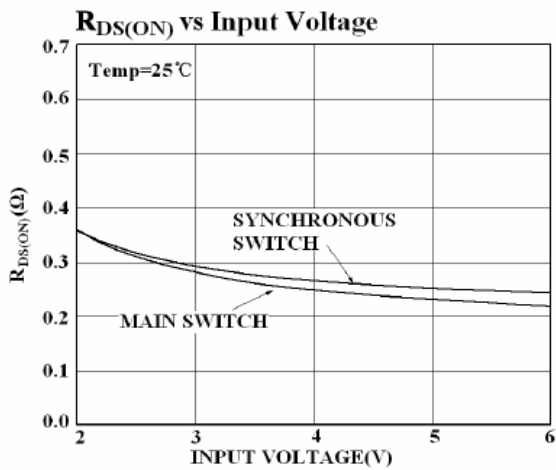
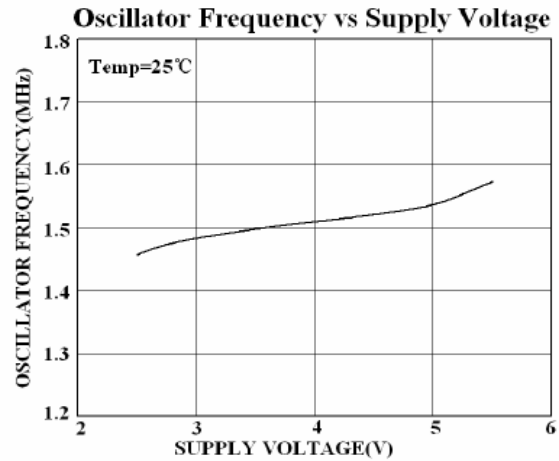
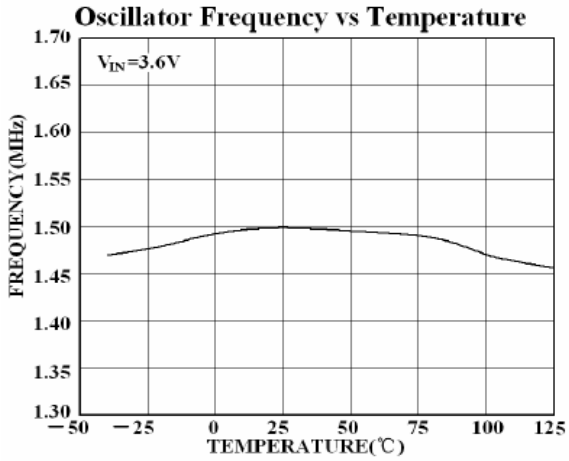

Discontinuous Operation

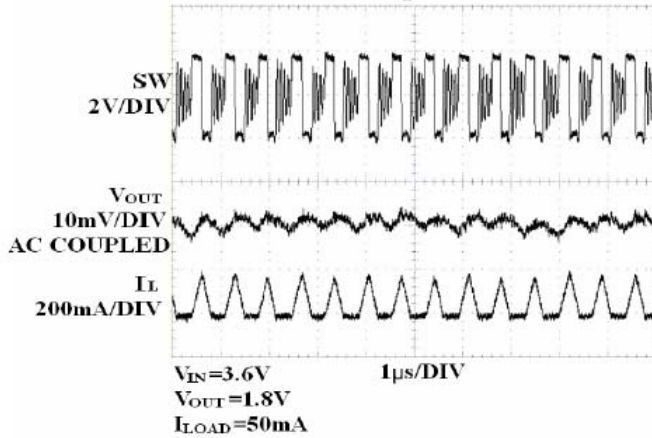

Start-Up from Shutdown

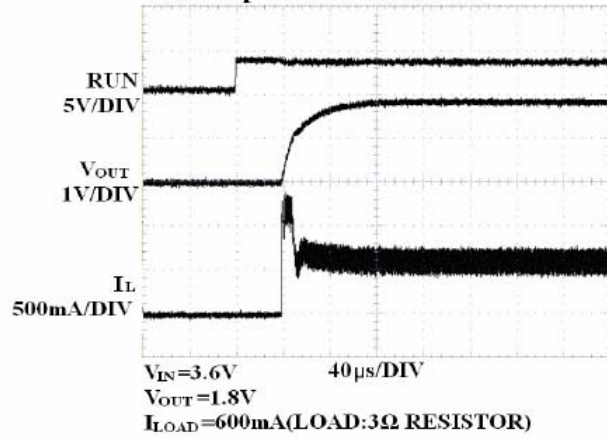

Load Step

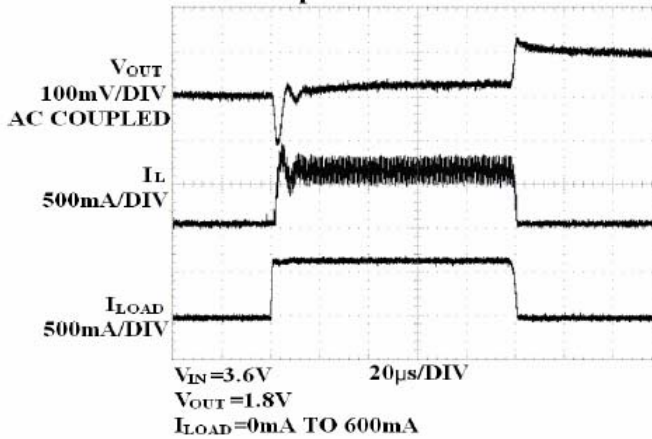

Load Step

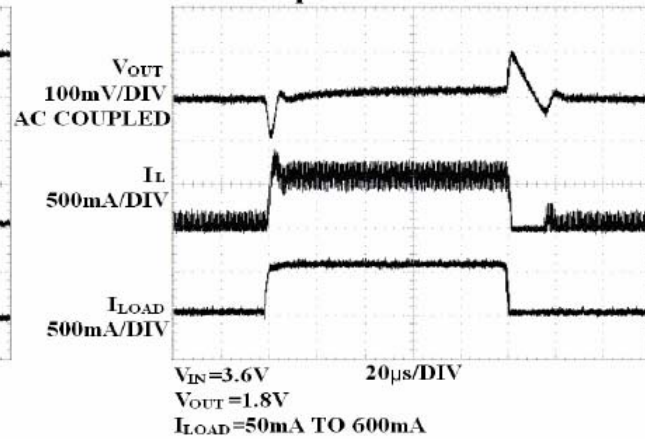

Load Step

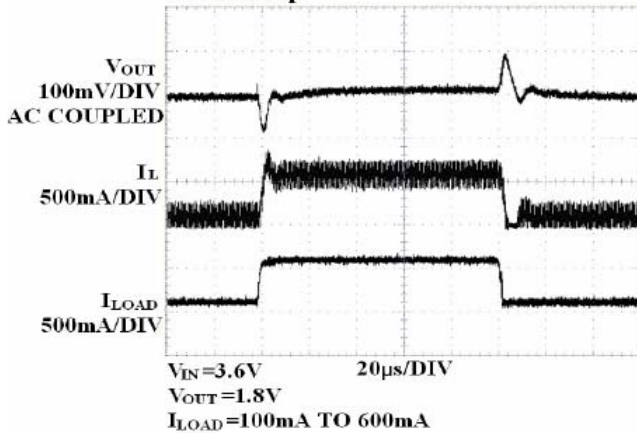

Load Step

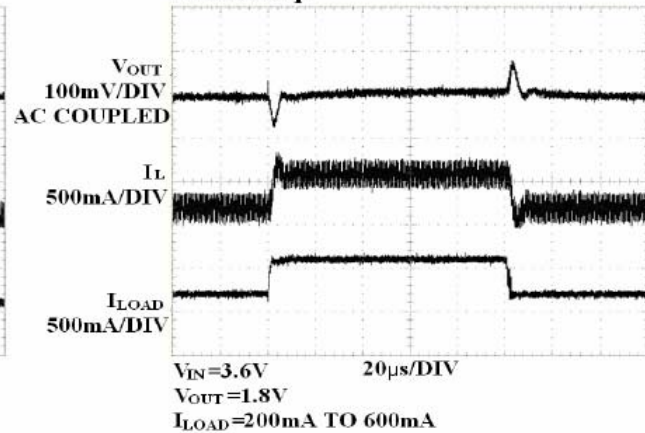

Applications Information

The basic LP3204 application circuit is shown in Typical Application Circuit. External component selection is determined by the maximum load current and begins with the selection of the inductor value and operating frequency followed by C_{IN} and C_{OUT}.

Inductor Selection

The output inductor is selected to limit the ripple current to some predetermined value, typically 20%~40% of the full load current at the maximum input voltage. Large value inductors lower ripple currents. Higher V_{IN} or V_{OUT} also increases the ripple current as shown in equation. A reasonable starting point for setting ripple current is ΔI_L=240mA (40% of 600mA).

$$\Delta I_L = \frac{1}{(f)(L)} V_{OUT} \left(1 - \frac{V_{OUT}}{V_{IN}} \right)$$

The DC current rating of the inductor should be at least equal to the maximum load current plus half the ripple current to prevent core saturation. Thus, a 720mA rated inductor should be enough for most applications (600mA+120mA). For better efficiency, choose a low DC-resistance inductor.

C_{IN} and C_{OUT} Selection

The input capacitance, C_{IN}, is needed to filter the trapezoidal current at the source of the top MOSFET. To prevent large ripple voltage, a low ESR input capacitor sized for the maximum RMS current should be used. RMS current is given by :

$$I_{RMS} = I_{OUT(MAX)} \frac{V_{OUT}}{V_{IN}} \sqrt{\frac{V_{IN}}{V_{OUT}} - 1}$$

This formula has a maximum at V_{IN} = 2V_{OUT}, where I_{RMS} = I_{OUT}/2. This simple worst-case condition is commonly used for design because even significant deviations do not offer much relief. Note that ripple current ratings from

capacitor manufacturers are often based on only 2000 hours of life which makes it advisable to further derate the capacitor, or choose a capacitor rated at a higher temperature than required. Several capacitors may also be paralleled to meet size or height requirements in the design.

The selection of C_{OUT} is determined by the effective series resistance (ESR) that is required to minimize voltage ripple and load step transients, as well as the amount of bulk capacitance that is necessary to ensure that the control loop is stable. Loop stability can be checked by viewing the load transient response as described in a later section. The output ripple, ΔV_{OUT}, is determined by :

$$\Delta V_{OUT} \leq \Delta I_L \left[ESR + \frac{1}{8fC_{OUT}} \right]$$

Using Ceramic Input and Output Capacitors

Higher values, lower cost ceramic capacitors are now becoming available in smaller case sizes. Their high ripple current, high voltage rating and low ESR make them ideal for switching regulator applications. However, care must be taken when these capacitors are used at the input and output. When a ceramic capacitor is used at the input and the power is supplied by a wall adapter through long wires, a load step at the output can induce ringing at the input, V_{IN}. At best, this ringing can couple to the output and be mistaken as loop instability. At worst, a sudden inrush of current through the long wires can potentially cause a voltage spike at V_{IN} large enough to damage the part.

Output Voltage Programming

The output voltage is set by a resistive divider according to the following formula:

$$V_{OUT} = 0.6V \left(1 + \frac{R2}{R1} \right)$$

The external resistive divider is connected to the output, allowing remote voltage sensing as shown in Figure3.

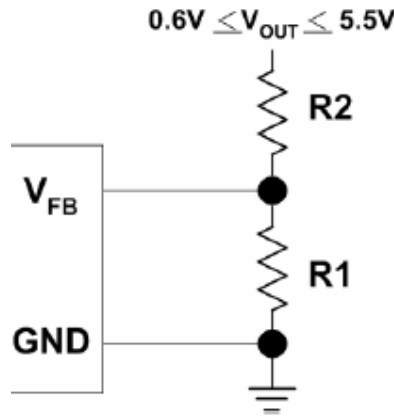

Figure3.

Efficiency Considerations

The efficiency of a switching regulator is equal to the output power divided by the input power times 100%. It is often useful to analyze individual losses to determine what is limiting the efficiency and which change would produce the most improvement. Efficiency can be expressed as :

$$\text{Efficiency} = 100\% - (L1 + L2 + L3 + \dots)$$

where L1, L2, etc. are the individual losses as a percentage of input power. Although all dissipative elements in the circuit produce losses, two main sources usually account for most of the losses : V_{IN} quiescent current and I^2R losses. The V_{IN} quiescent current loss dominates the efficiency loss at very low load currents whereas the I^2R loss dominates the efficiency loss at medium to high load currents. In a typical efficiency plot, the efficiency curve at very low load currents can be misleading since the actual power lost is of no consequence.

1. The V_{IN} quiescent current is due to two components : the DC bias current as given in the electrical characteristics and the internal main switch and synchronous switch gate charge currents. The gate charge current results from switching the gate capacitance of the internal power MOSFET switches. Each time the gate is switched from high to low to high again, a packet of charge ΔQ moves from V_{IN} to ground.

The resulting $\Delta Q/\Delta t$ is the current out of V_{IN} that is typically larger than the DC bias current. In continuous mode,

$$I_{\text{GATECHG}} = f(Q_T + Q_B)$$

where Q_T and Q_B are the gate charges of the internal top and bottom switches. Both the DC bias and gate charge losses are proportional to V_{IN} and thus their effects will be more pronounced at higher supply voltages.

2. I^2R losses are calculated from the resistances of the internal switches, R_{SW} and external inductor R_L . In continuous mode the average output current flowing through inductor L is "chopped" between the main switch and the synchronous switch. Thus, the series resistance looking into the LX pin is a function of both top and bottom MOSFET $R_{DS(ON)}$ and the duty cycle (DC) as follows :

$$R_{SW} = R_{DS(ON)TOP} \times DC + R_{DS(ON)BOT} \times (1 - DC)$$

The $R_{DS(ON)}$ for both the top and bottom MOSFETs can be obtained from the Typical Performance Characteristics curves. Thus, to obtain I^2R losses, simply add R_{SW} to R_L and multiply the result by the square of the average output current.

Other losses including C_{IN} and C_{OUT} ESR dissipative losses and inductor core losses generally account for less than 2% of the total loss.

Checking Transient Response

The regulator loop response can be checked by looking at the load transient response. Switching regulators take several cycles to respond to a step in load current. When a load step occurs, VOUT immediately shifts by an amount equal to ΔI_{LOAD} (ESR), where ESR is the effective series resistance of COUT. ΔI_{LOAD} also begins to charge or discharge COUT generating a feedback error signal used by the regulator to return VOUT to its steady-state value. During this recovery time, VOUT can be monitored for overshoot or ringing that would indicate a stability problem.

Layout Considerations

- Follow the PCB layout guidelines for optimal performance of LP3204.
- For the main current paths as indicated in bold lines, keep their traces short and wide.
- Put the input capacitor as close as possible to the device pins (VIN and GND).
- LX node is with high frequency voltage swing and should be kept small area. Keep analog components away from LX node to prevent stray capacitive noise pick-up.
- Connect feedback network behind the output capacitors. Keep the loop area small. Place the feedback components near the LP3204.
- Connect all analog grounds to a command node and then connect the command node to the power ground behind the output capacitors.

Packaging Information

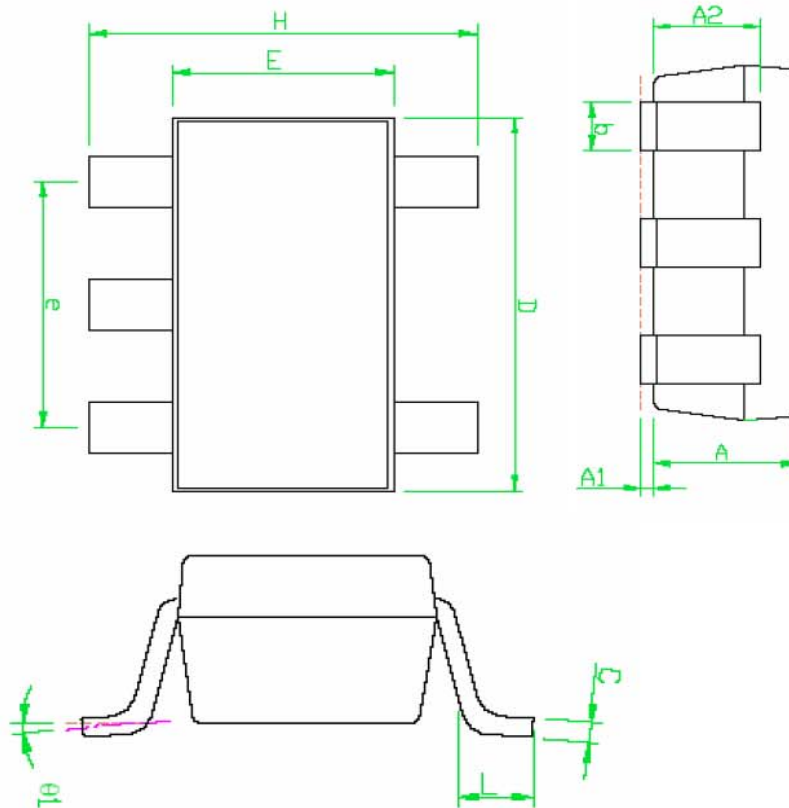

Note:

1. Package body sizes exclude mold flash protrusions or gate burrs.
2. Tolerance $\pm 0.1000\text{mm}$ (4 mil) unless otherwise specified.
3. Coplanarity: 0.1000mm
4. Dimension L is measured in gage plane.

Symbols	Dimension in Millimeters		
	Min.	Nom	Max.
A	1.00	1.10	1.30
A1	0.00	-----	0.10
A2	0.70	0.80	0.90
b	0.35	0.40	0.50
C	0.12	0.15	0.20
D	2.70	2.90	3.10
E	1.50	1.60	1.70
e	-----	1.90(Typ.)	-----
H	2.6	2.8	3.00
L	0.37	-----	-----
θ	14	5	9