

HIGH SPEED PRECISION QUAD OPERATIONAL AMPLIFIERS

- LOW OFFSET VOLTAGE : 500 μ V max.
- LOW POWER CONSUMPTION
- SHORT CIRCUIT PROTECTION
- LOW DISTORTION, LOW NOISE
- HIGH GAIN-BANDWIDTH PRODUCT
- HIGH CHANNEL SEPARATION
- ESD INTERNAL PROTECTION

- **MACROMODEL** INCLUDED IN THIS SPECIFICATION

DESCRIPTION

The TS514 is a high performance quad operational amplifier with frequency and phase compensation built into the chip. The internal phase compensation allows stable operation as voltage follower in spite of its high gain-bandwidth products.

The circuit presents very stable electrical characteristics over the entire supply voltage range, and it particularly intended for professional and telecom applications (active filters, etc).

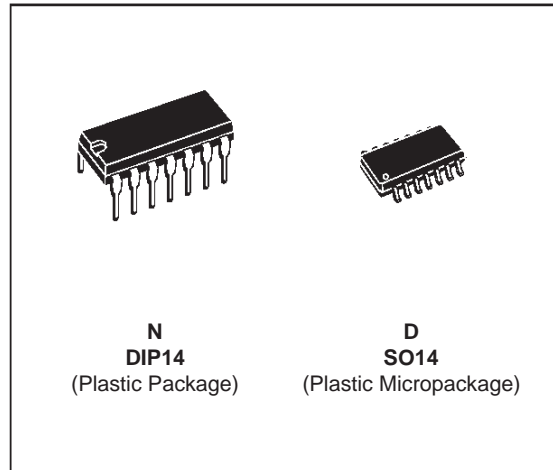

ORDER CODES

| Part Number | Temperature Range | Package | |
|-------------|-------------------|---------|---|
| | | N | D |
| TS514I | -40°C, +125°C | • | • |
| TS514AI | -40°C, +125°C | • | • |

PIN CONNECTIONS (top view)

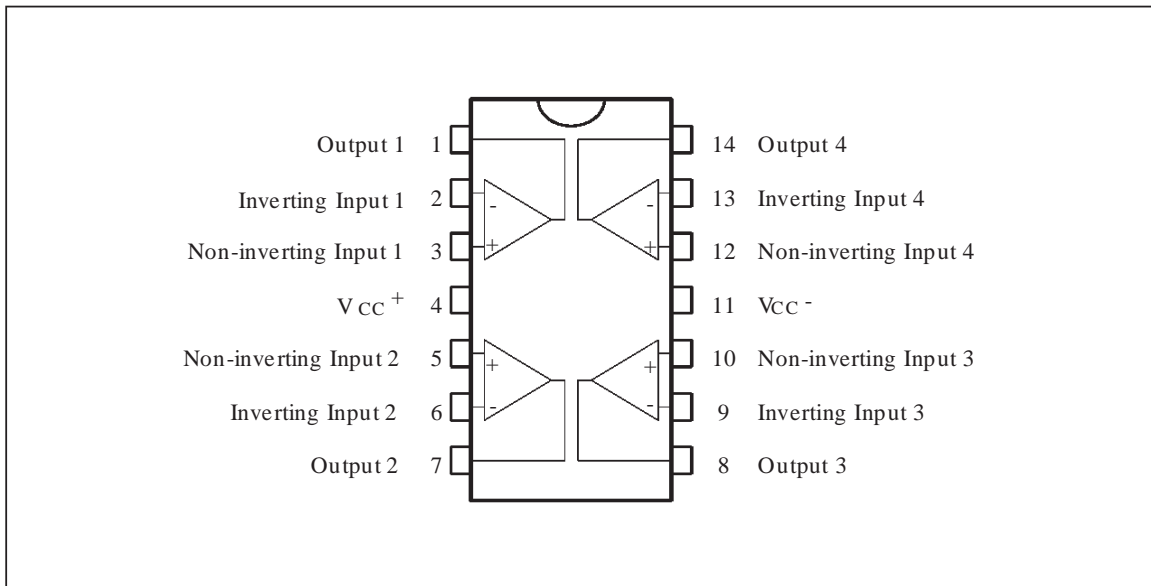

SCHEMATIC DIAGRAM (1/2 TS514)

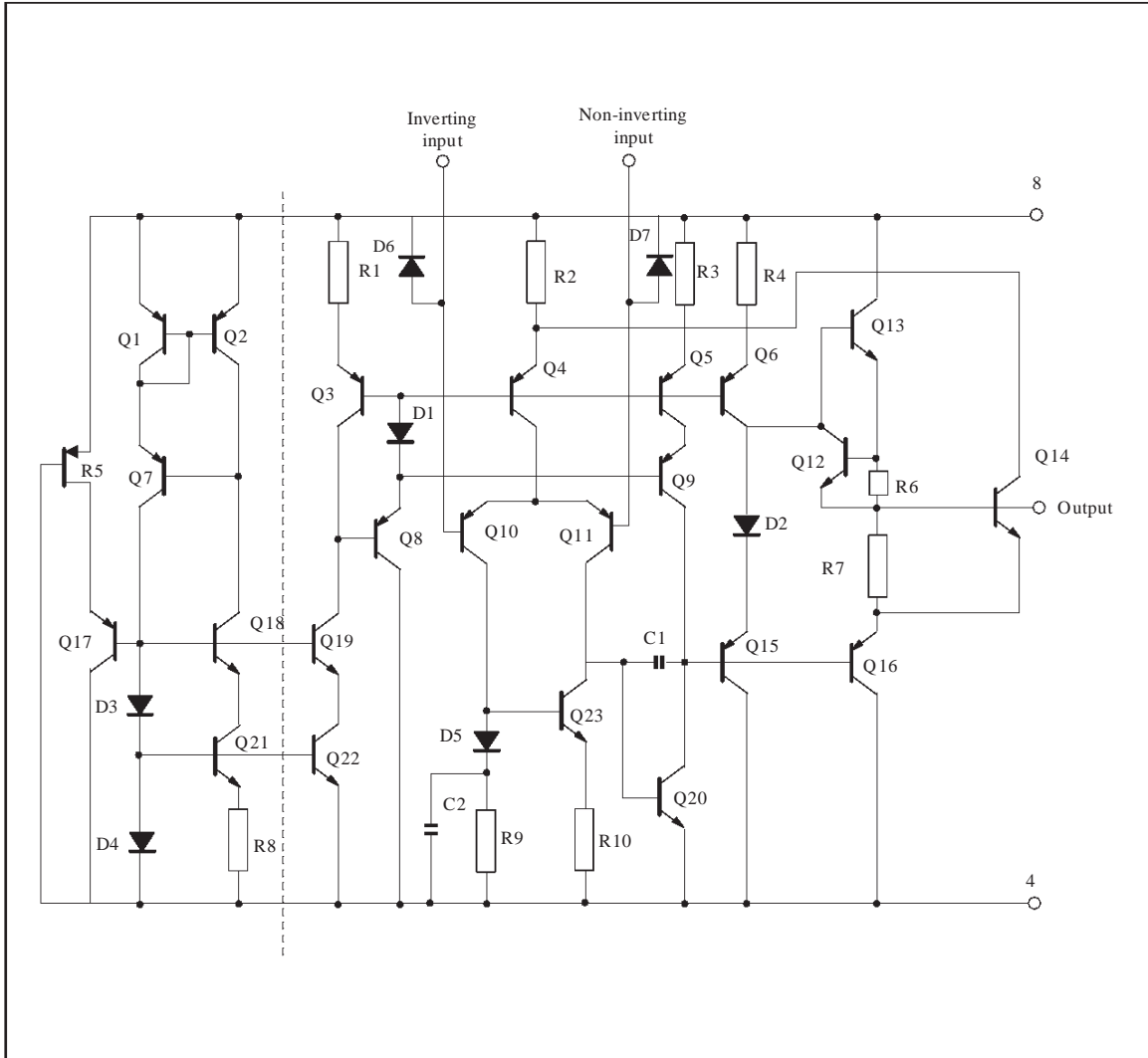

ABSOLUTE MAXIMUM RATINGS

| Symbol | Parameter | Value | Unit |
|-------------------|----------------------------------------------|--------------------------------------------|------|
| V _{CC} | Supply Voltage | ±18 | V |
| V _i | Input Voltage (positive) (negative) | +V _{CC} -V _{CC} - 0.5 | V |
| V _{id} | Differential Input Voltage | ±(V _{CC} - 1) | |
| T _{oper} | Operating Temperature Range | -40 to +125 | °C |
| P _{tot} | Power Dissipation at T _{amb} = 70°C | 400 | mW |
| T _{stg} | Storage Temperature | -65 to 150 | °C |

ELECTRICAL CHARACTERISTICS ($V_{CC} = \pm 15V$, $T_{amb} = 25^{\circ}C$, unless otherwise specified)

| Symbol | Parameter | Test Conditions | Min. | Typ. | Max. | Unit |
|-----------------|--------------------------------|-------------------------------------------------------------------------|----------|---------------|------------|------------------------|
| I_{CC} | Supply Current | | | 1.4 | 2.4 | mA |
| I_{ib} | Input Bias Current | | | 50 | 150 | nA |
| | | $T_{min.} < T_{op} < T_{max.}$ | | | 300 | nA |
| R_i | Input Resistance | $f = 1kHz$ | | 1 | | M Ω |
| V_{io} | Input Offset Voltage | TS514 TS514A | | 0.5 | 2.5 0.5 | mV |
| | | $T_{min.} < T_{op} < T_{max.}$ TS514 TS514A | | | 4 1.5 | mV |
| DV_{io} | Input Offset Voltage Drift | $T_{min.} < T_{op} < T_{max.}$ | | 5 | | $\mu V/^{\circ}C$ |
| I_{io} | Input Offset Current | | | 5 | 20 | nA |
| | | $T_{min.} < T_{op} < T_{max.}$ | | | 40 | nA |
| DI_{io} | Input Offset Current Drift | $T_{min.} < T_{op} < T_{max.}$ | | 0.08 | | $\frac{nA}{^{\circ}C}$ |
| I_{os} | Output Short Circuit Current | | | 23 | | mA |
| A_{vd} | Large Signal Voltage Gain | $R_L = 2k\Omega$ $V_{CC} = \pm 15V$ $V_{CC} = \pm 4V$ | 90 | 100 95 | | dB |
| GBP | Gain-bandwidth Product | $f = 100kHz$ | 1.8 | 3 | | MHz |
| e_n | Equivalent Input Noise Voltage | $f = 1kHz$ $R_S = 50\Omega$ $R_S = 1k\Omega$ $R_S = 10k\Omega$ | | 8 10 18 | 15 | $\frac{nV}{\sqrt{Hz}}$ |
| THD | Total Harmonic Distortion | $A_V = 20dB$ $R_L = 2k\Omega$ $V_O = 2V_{PP}$ $f = 1kHz$ | | 0.03 | 0.1 | % |
| $\pm V_{opp}$ | Output Voltage Swing | $R_L = 2k\Omega$ $V_{CC} = \pm 15V$ $V_{CC} = \pm 4V$ | ± 13 | ± 3 | | V |
| V_{opp} | Large Signal Voltage Swing | $R_L = 10k\Omega$ $f = 10kHz$ | | 28 | | V_{PP} |
| SR | Slew Rate | Unity Gain, $R_L = 2k\Omega$ | 0.8 | 1.5 | | V/ μs |
| CMR | Common Mode Rejection Ratio | $V_{ic} = 10V$ | 90 | | | dB |
| SVR | Supply Voltage Rejection Ratio | $V_{ic} = 1V$ $f = 100Hz$ | 90 | | | dB |
| V_{O1}/V_{O2} | Channel Separation | $f = 1kHz$ | 100 | 120 | | dB |

TS514,A

- SINGLE OR SPLIT SUPPLY OPERATION
- LOW POWER CONSUMPTION
- SHORT CIRCUIT PROTECTION
- LOW DISTORTION, LOW NOISE
- HIGH GAIN-BANDWIDTH PRODUCT
- HIGH CHANNEL SEPARATION

Applies to : TS514i,AI

** Standard Linear Ics Macromodels, 1993.

** CONNECTIONS :

* 1 INVERTING INPUT

* 2 NON-INVERTING INPUT

* 3 OUTPUT

* 4 POSITIVE POWER SUPPLY

* 5 NEGATIVE POWER SUPPLY

.SUBCKT TS514 1 3 2 4 5 (analog)

.MODEL MDTH D IS=1E-8 KF=6.647807E-16 CJO=10F

* INPUT STAGE

CIP 2 5 1.000000E-12

CIN 1 5 1.000000E-12

EIP 10 5 2 5 1

EIN 16 5 1 5 1

RIP 10 11 1.300000E+01

RIN 15 16 1.300000E+01

RIS 11 15 6.437882E+01

DIP 11 12 MDTH 400E-12

DIN 15 14 MDTH 400E-12

VOFP 12 13 DC 0

VOFN 13 14 DC 0

IPOL 13 5 2.000000E-05

CPS 11 15 9.75E-10

DINN 17 13 MDTH 400E-12

VIN 17 5 0.000000E+00

DINR 15 18 MDTH 400E-12

VIP 4 18 1.500000E+00

FCP 4 5 VOFP 1.525000E+01

FCN 5 4 VOFN 1.525000E+01

FIBP 2 5 VOFN 5.000000E-03

FIBN 5 1 VOFP 5.000000E-03

* AMPLIFYING STAGE

FIP 5 19 VOFP 1.125000E+03

FIN 5 19 VOFN 1.125000E+03

RG1 19 5 6.512062E+05

RG2 19 4 6.512062E+05

CC 19 29 1.500000E-08

HZTP 30 29 VOFP 8.944787E+02

HZTN 5 30 VOFN 8.944787E+02

DOPM 19 22 MDTH 400E-12

DONM 21 19 MDTH 400E-12

HOPM 22 28 VOUT 6.521739E+03

VIPM 28 4 1.500000E+02

HONM 21 27 VOUT 6.521739E+03

VINM 5 27 1.500000E+02

GCOMP 5 4 4 5 7.485029E-04

RPM1 5 80 1E+09

RPM2 4 80 1E+09

GAVPH 5 82 19 80 2.99E-03

RAVPHGH 82 4 668

RAVPHGB 82 5 668

RAVPHDH 82 83 1000

RAVPHDB 82 84 1000

CAVPHH 4 83 0.352E-09

CAVPHB 5 84 0.352E-09

EOUT 26 23 82 5 1

VOUT 23 5 0

ROUT 26 3 150

COUT 3 5 1.000000E-12

DOP 19 25 MDTH 400E-12

VOP 4 25 1.785252E+00

DON 24 19 MDTH 400E-12

VON 24 5 1.785252E+00

.ENDS

ELECTRICAL CHARACTERISTICS

$V_{CC} = \pm 15V$, $T_{amb} = 25^{\circ}C$ (unless otherwise specified)

| Symbol | Conditions | Value | Unit |
|-----------------|----------------------------------|-------------|------------|
| V_{io} | | 0 | mV |
| A_{vd} | $R_L = 2k\Omega$ | 94 | V/mV |
| I_{CC} | No load, per operator | 325 | μA |
| V_{icm} | | -15 to 13.5 | V |
| V_{OH} | $R_L = 2k\Omega$ | +13 | V |
| V_{OL} | $R_L = 2k\Omega$ | -13 | V |
| I_{sink} | $V_O = 0V$ | 24 | mA |
| I_{source} | $V_O = 0V$ | 24 | mA |
| GBP | $R_L = 2k\Omega$, $C_L = 100pF$ | 3 | MHz |
| SR | $R_L = 2k\Omega$, $C_L = 100pF$ | 1.4 | V/ μs |
| $\varnothing m$ | $R_L = 2k\Omega$, $C_L = 100pF$ | 55 | Degrees |

PACKAGE MECHANICAL DATA
14 PINS - PLASTIC DIP

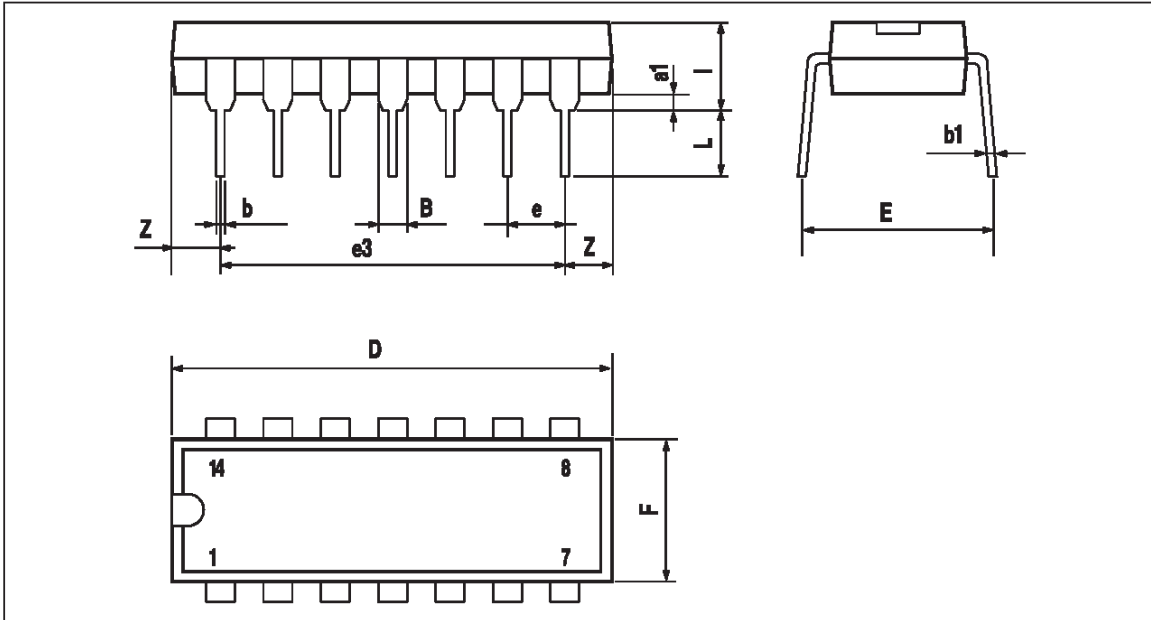

| Dim. | Millimeters | | | Inches | | |
|------|-------------|-------|------|--------|-------|-------|
| | Min. | Typ. | Max. | Min. | Typ. | Max. |
| a1 | 0.51 | | | 0.020 | | |
| B | 1.39 | | 1.65 | 0.055 | | 0.065 |
| b | | 0.5 | | | 0.020 | |
| b1 | | 0.25 | | | 0.010 | |
| D | | | 20 | | | 0.787 |
| E | | 8.5 | | | 0.335 | |
| e | | 2.54 | | | 0.100 | |
| e3 | | 15.24 | | | 0.600 | |
| F | | | 7.1 | | | 0.280 |
| i | | | 5.1 | | | 0.201 |
| L | | 3.3 | | | 0.130 | |
| Z | 1.27 | | 2.54 | 0.050 | | 0.100 |

PACKAGE MECHANICAL DATA
14 PINS - PLASTIC MICROPACKAGE (SO)

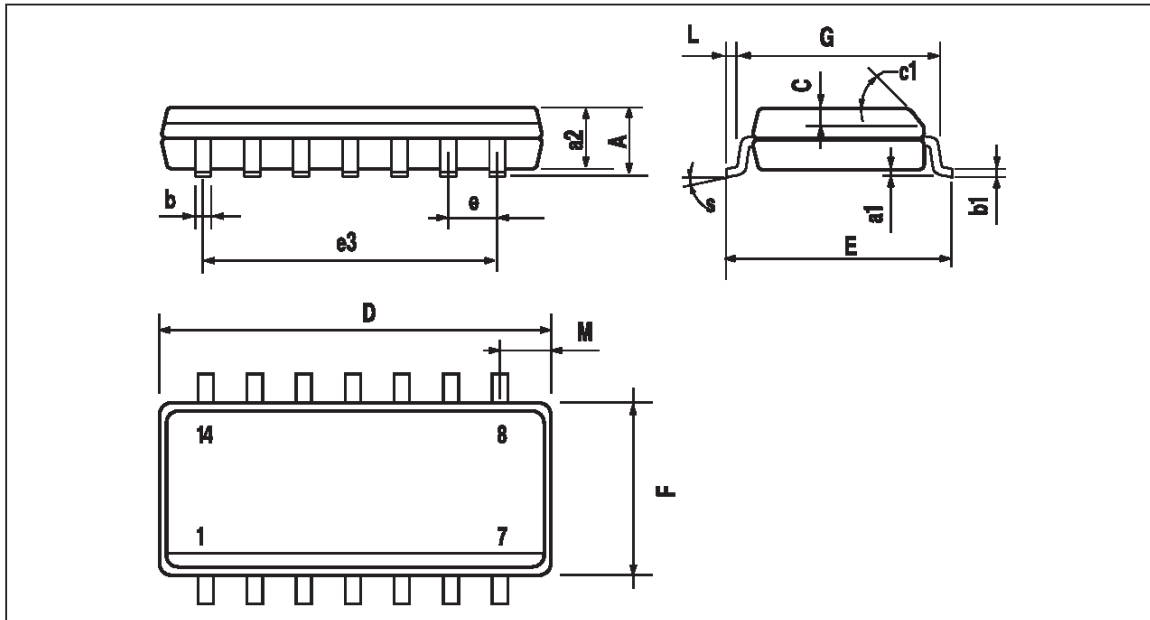

| Dim. | Millimeters | | | Inches | | |
|------|-------------|------|------|--------|-------|-------|
| | Min. | Typ. | Max. | Min. | Typ. | Max. |
| A | | | 1.75 | | | 0.069 |
| a1 | 0.1 | | 0.2 | 0.004 | | 0.008 |
| a2 | | | 1.6 | | | 0.063 |
| b | 0.35 | | 0.46 | 0.014 | | 0.018 |
| b1 | 0.19 | | 0.25 | 0.007 | | 0.010 |
| C | | 0.5 | | | 0.020 | |
| c1 | 45° (typ.) | | | | | |
| D | 8.55 | | 8.75 | 0.336 | | 0.334 |
| E | 5.8 | | 6.2 | 0.228 | | 0.244 |
| e | | 1.27 | | | 0.050 | |
| e3 | | 7.62 | | | 0.300 | |
| F | 3.8 | | 4.0 | 0.150 | | 0.157 |
| G | 4.6 | | 5.3 | 0.181 | | 0.208 |
| L | 0.5 | | 1.27 | 0.020 | | 0.050 |
| M | | | 0.68 | | | 0.027 |
| S | 8° (max.) | | | | | |

Information furnished is believed to be accurate and reliable. However, SGS-THOMSON Microelectronics assumes no responsibility for the consequences of use of such information nor for any infringement of patents or other rights of third parties which may result from its use. No license is granted by implication or otherwise under any patent or patent rights of SGS-THOMSON Microelectronics. Specifications mentioned in this publication are subject to change without notice. This publication supersedes and replaces all information previously supplied. SGS-THOMSON Microelectronics products are not authorized for use as critical components in life support devices or systems without express written approval of SGS-THOMSON Microelectronics.

© 1997 SGS-THOMSON Microelectronics – Printed in Italy – All Rights Reserved

SGS-THOMSON Microelectronics GROUP OF COMPANIES

Australia - Brazil - Canada - China - France - Germany - Italy - Japan - Korea - Malaysia - Malta - Morocco
The Netherlands - Singapore - Spain - Sweden - Switzerland - Taiwan - Thailand - United Kingdom - U.S.A.