



## PA1517

### LINEAR INTEGRATED CIRCUIT

## 2 × 6 W STEREO POWER AMPLIFIER

### DESCRIPTION

The UTC **PA1517** is an integrated class-B dual output amplifier. It is mainly using for multi-media applications.

### FEATURES

- \* Needs very few external components
- \* High output power
- \* Fixed gain
- \* Very good ripple rejection
- \* Mute/standby switch
- \* AC and DC short-circuit safe to ground and  $V_{CC}$
- \* Thermally protected
- \* Reverse polarity safe
- \* Can handle high energy on outputs ( $V_{CC} = 0V$ )
- \* Have no switch-on/switch-off plop
- \* Electrostatic discharge protection.

### ORDERING INFORMATION

Ordering Number		Package	Packing
Normal	Lead Free Plating		
PA1517-D18-T	PA1517L-D18-T	DIP-18	Tube
PA1517-D20-T	PA1517L-D20-T	DIP-20	Tube

<p>PA1517L-D18-T</p> <p>(1) Packing Type (2) Package Type (3) Lead Plating</p>	<p>(1) T: Tube (2) D18: DIP-18, D20: DIP-20 (3) L: Lead Free Plating, Blank: Pb/Sn</p>
--	--

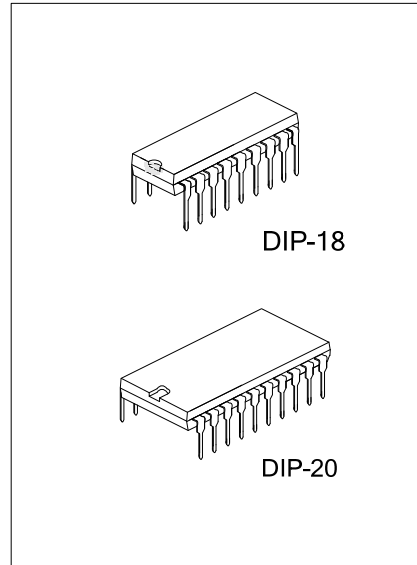

\*Pb-free plating product number: PA1517L

## ■ PIN CONFIGURATION

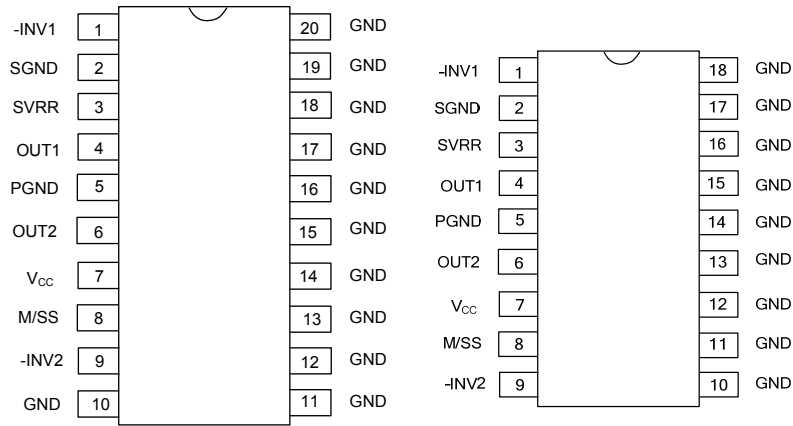

## ■ PIN DESCRIPTIONS

PIN NO.	PIN NAME	PIN FUNCTION
1	-INV1	Non-inverting input 1
2	SGND	Signal ground
3	SVRR	Output of supply voltage ripple rejection
4	OUT1	Output 1
5	PGND	Power ground
6	OUT2	Output 2
7	V <sub>CC</sub>	Supply voltage input
8	M/SS	Input of mute/standby switch
9	-INV2	Non-inverting input 2
10	GND	GND
11	GND	GND
12	GND	GND
13	GND	GND
14	GND	GND
15	GND	GND
16	GND	GND
17	GND	GND
18	GND	GND
19	GND	GND
20	GND	GND

# PA1517

## LINEAR INTEGRATED CIRCUIT

### ■ BLOCK DIAGRAM

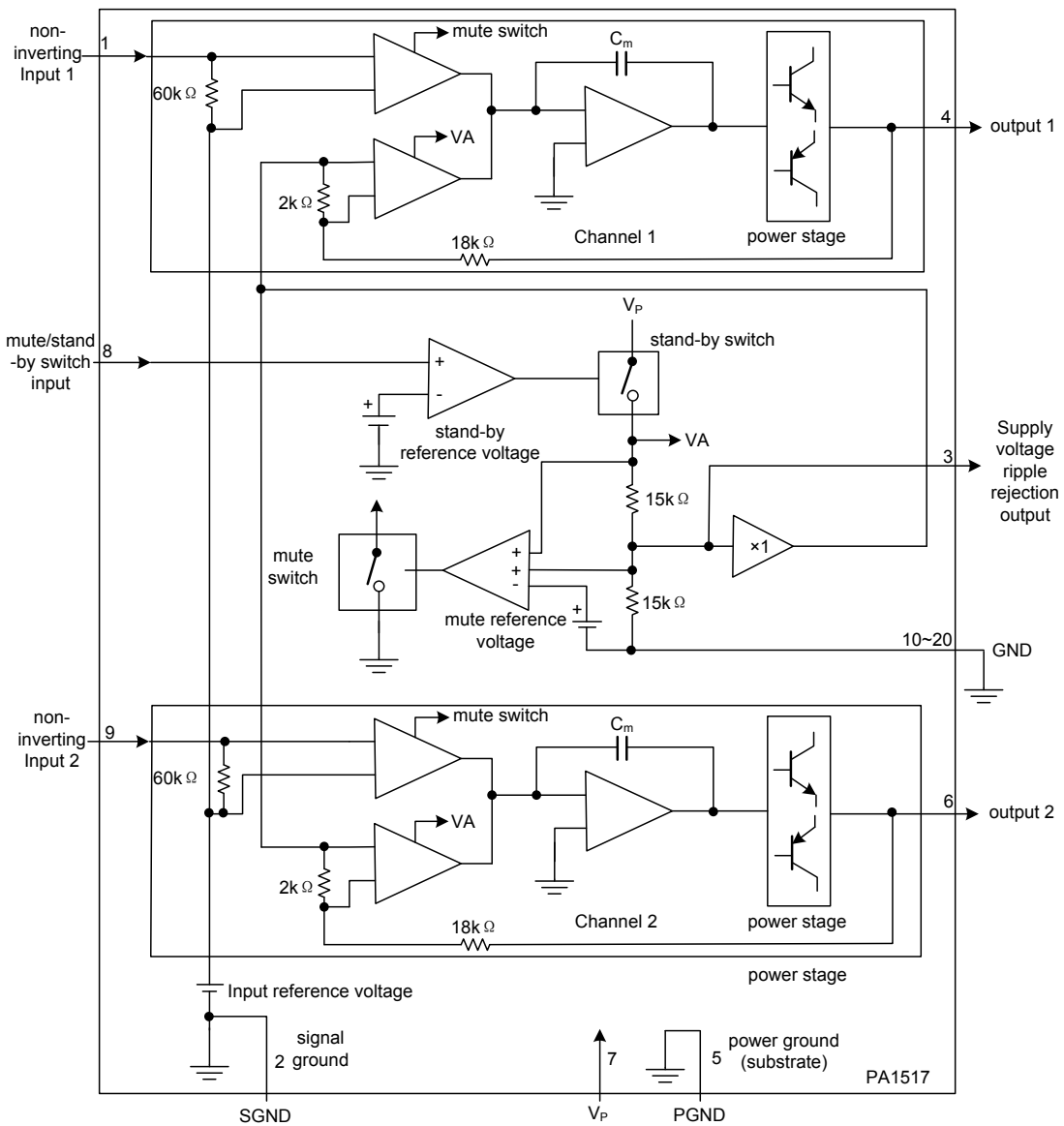

### ■ ABSOLUTE MAXIMUM RATINGS

PARAMETER		SYMBOL	RATINGS	UNIT
Supply Voltage	Operating	$V_{CC}$	18	V
	No Signal		20	
AC and DC Short-Circuit Safe Voltage		$V_{CC(SC)}$	18	V
Reverse Polarity		$V_{CC(R)}$	6	V
Energy Handling Capability at Outputs ( $V_{CC}=0V$ )		$ERG_O$	200	mJ
Peak Output Current	Non-Repetitive	$I_{OSM}$	4	A
	Repetitive		2.5	
Total Power Dissipation		$P_D$	15	W
Junction Temperature		$T_J$	150	$^{\circ}C$
Operating Temperature		$T_{OPR}$	-40 ~ +85	$^{\circ}C$
Storage Temperature		$T_{STG}$	-55 ~ +150	$^{\circ}C$

Note: Absolute maximum ratings are those values beyond which the device could be permanently damaged. Absolute maximum ratings are stress ratings only and functional device operation is not implied.

### ■ THERMAL DATA

PARAMETER	SYMBOL	MIN	TYP	MAX	UNIT
Thermal Resistance from Junction to Ambient	$\theta_{JA}$		50		$^{\circ}C/W$

### ■ RECOMMENDED OPERATING CONDITIONS

PARAMETER	SYMBOL	TEST CONDITIONS	MIN	TYP	MAX	UNIT
Supply Voltage	$V_{CC}$		6.0	14.4	18.0	V
Repetitive Peak Output Current	$I_{ORM}$				2.5	A
Total Quiescent Current	$I_Q$			40	80	mA
Standby Current	$I_{SB}$			0.1	100	$\mu A$
Switch-on Current	$I_{SW}$				40	$\mu A$
Input Impedance	$ Z_i $		50			k $\Omega$
Output Power	$P_{OUT}$	$R_L = 4 \Omega$ ; THD = 0.5%		5		W
		$R_L = 4 \Omega$ ; THD = 10%		6		W
Supply Voltage Ripple Rejection	SVRR	$f_i = 100 \text{ Hz to } 10 \text{ kHz}$	48			dB
Channel Separation	$\alpha_{CS}$		40			dB
Closed Loop Voltage Gain	$G_V$		19	20	21	dB
Noise Output Voltage (RMS Value)	$V_{NO(RMS)}$			50		$\mu V$

### ■ ELECTRICAL CHARACTERISTICS ( $T_a = 25^{\circ}C$ ; unless otherwise specified)

PARAMETER	SYMBOL	TEST CONDITIONS	MIN	TYP	MAX	UNIT
<b>DC ELECTRICAL CHARACTERISTICS (<math>V_{CC} = 14.4 \text{ V}</math>)</b>						
<b>SUPPLY</b>						
Supply Voltage	$V_{CC}$	Note 1	6.0	14.4	18.0	V
Total Quiescent Current	$I_{Q(TOT)}$			40	80	mA
DC Output Voltage	$V_{OUT}$			6.95		V
<b>MUTE/STAND-BY SWITCH</b>						
Switch-on Voltage Level	$V_{\delta}$		8.5			V
<b>MUTE CONDITION</b>						
Output Signal in Mute Position	$V_{OUT}$	$V_{I(MAX)} = 1V; f_i = 20\text{Hz to } 15\text{kHz}$			2	mV
<b>STAND-BY CONDITION</b>						
DC Current in Standby Condition	$I_{SB}$				100	$\mu A$
Switch-on Current	$I_{SW}$			12	40	$\mu A$

■ ELECTRICAL CHARACTERISTICS

PARAMETER	SYMBOL	TEST CONDITIONS	MIN	TYP	MAX	UNIT	
<b>AC ELECTRICAL CHARACTERISTICS</b> ( $V_{CC} = 14.4\text{ V}$ ; $R_L = 4\Omega$ ; $f = 1\text{ kHz}$ )							
Output Power	$P_{OUT}$	THD = 0.5%; Note 1	4	5		W	
		THD = 10%; Note 1	5.5	6.0		W	
Total Harmonic Distortion	THD	$P_{OUT} = 1\text{ W}$		0.1		%	
Low Frequency Roll-Off	$f_{LR}$	at -3 dB; Note 2		45		Hz	
High Frequency Roll-Off	$f_{HR}$	at -1dB	20			kHz	
Closed Loop Voltage Gain	$G_V$	Untrimmed	19	20	21		
Supply Voltage Ripple Rejection	On	SVRR	Note 3	48		dB	
	Mute			48		dB	
	Stand-by			80		dB	
Input Impedance	$ Z_{IN} $		50	60	75	k $\Omega$	
Noise Output Voltage	On	$V_{NO}$	$R_S = 0\Omega$ ; Note 4	50		$\mu\text{V}$	
	On			$R_S = 10\Omega$ ; Note 4	70	100	$\mu\text{V}$
	Mute			Note 5	50		$\mu\text{V}$
Channel Separation	$\alpha_{CS}$	$R_S = 10\Omega$	40			dB	
Channel Unbalance	$ \Delta G_V $			0.1	1	dB	

Notes: 1. Output power is measured at the output pins of the IC.

2. Frequency response externally fixed.

3. Ripple rejection measured at the output with a source impedance of  $0\Omega$ , maximum ripple amplitude of 2 V(p-p) and a frequency between 100 Hz and 10 kHz.

4. Noise voltage measured in a bandwidth of 20 Hz to 20 kHz.

5. Noise output voltage independent of  $R_S$  ( $V_{IN} = 0\text{ V}$ ).

# PA1517

## LINEAR INTEGRATED CIRCUIT

### ■ TYPICAL APPLICATION

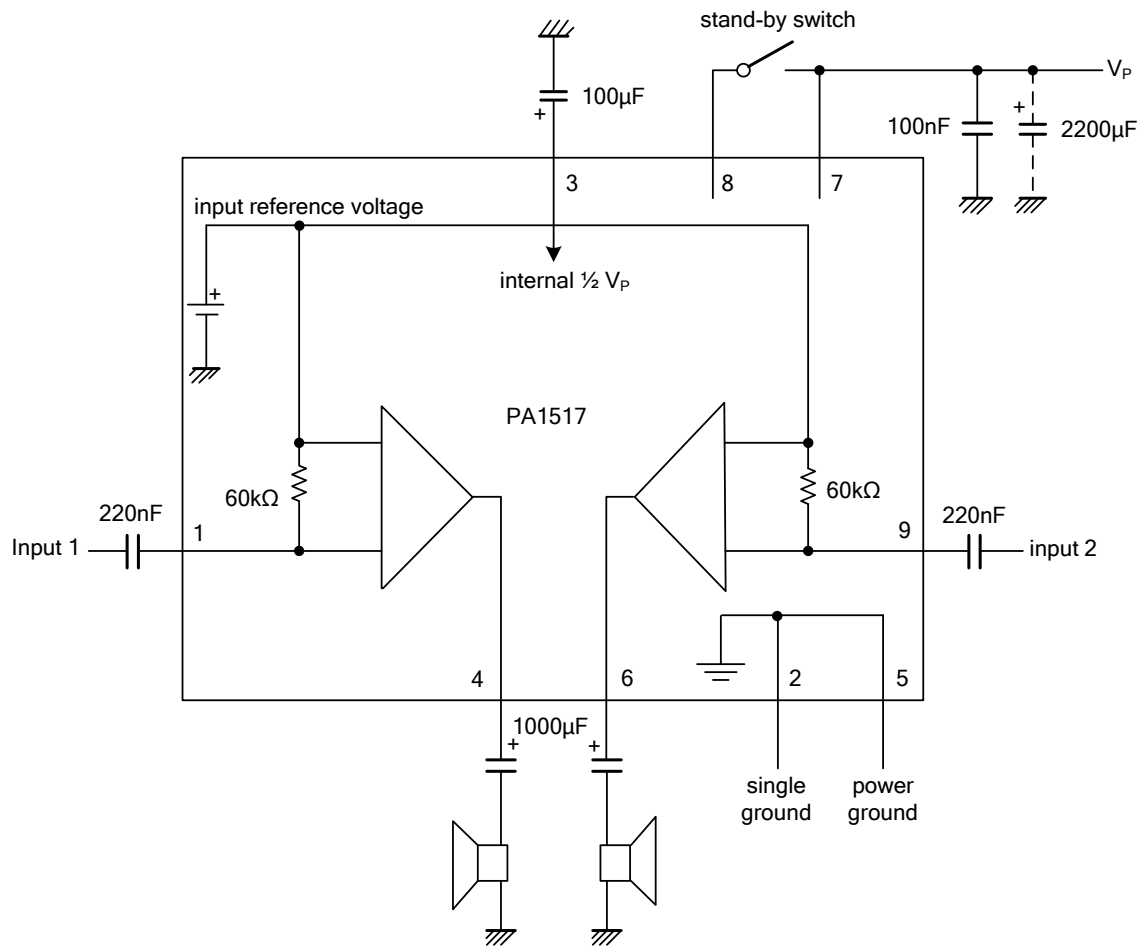

UTC assumes no responsibility for equipment failures that result from using products at values that exceed, even momentarily, rated values (such as maximum ratings, operating condition ranges, or other parameters) listed in products specifications of any and all UTC products described or contained herein. UTC products are not designed for use in life support appliances, devices or systems where malfunction of these products can be reasonably expected to result in personal injury. Reproduction in whole or in part is prohibited without the prior written consent of the copyright owner. The information presented in this document does not form part of any quotation or contract, is believed to be accurate and reliable and may be changed without notice.

