

OP292/OP492

FEATURES

Single-Supply Operation: 4.5 V to 33 V
Input Common-Mode Includes Ground
Output Swings to Ground
High Slew Rate: 3 V/ μ s
High Gain Bandwidth: 4 MHz
Low Input Offset Voltage
High Open-Loop Gain
No Phase Inversion
Low Cost

APPLICATIONS

Disk Drives
Mobile Phones
Servo Controls
Modems and Fax Machines
Pagers
Power Supply Monitors and Controls
Battery-Operated Instrumentation

GENERAL DESCRIPTION

The OP292/OP492 are low cost, general purpose dual and quad operational amplifiers designed for single-supply applications and are ideal for 5 volt systems.

Fabricated on Analog Devices' CBCMOS process, the OP292/OP492 series has a PNP input stage that allows the input voltage range to include ground. A BiCMOS output stage enables the output to swing to ground while sinking current.

The OP292/OP492 series is unity-gain stable and features an outstanding combination of speed and performance for single- or dual-supply operation. The OP292/OP492 provide high slew rate, high bandwidth, with open-loop gain exceeding 40,000 and offset voltage under 800 Ω (OP292) and 1 mV (OP492). With these combinations of features and low supply current, the OP292/OP492 series is an excellent choice for battery-operated applications.

The OP292/OP492 series performance is specified for single- or dual-supply voltage operation over the extended industrial temperature range (-40°C to $+125^{\circ}\text{C}$).

Package options for the OP292 and OP492 include plastic DIP, SO-8 (OP292) and SO-14.

REV. B

Information furnished by Analog Devices is believed to be accurate and reliable. However, no responsibility is assumed by Analog Devices for its use, nor for any infringements of patents or other rights of third parties that may result from its use. No license is granted by implication or otherwise under any patent or patent rights of Analog Devices.

PIN CONNECTIONS

8-Lead Narrow-Body SOIC
(S-Suffix)

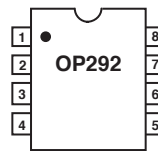

8-Lead Epoxy DIP
(P-Suffix)

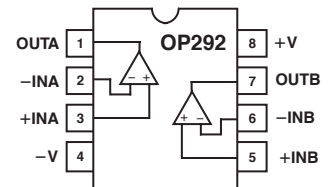

14-Lead Narrow-Body SOIC
(S-Suffix)

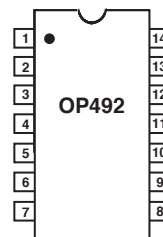

14-Lead Epoxy DIP
(P-Suffix)

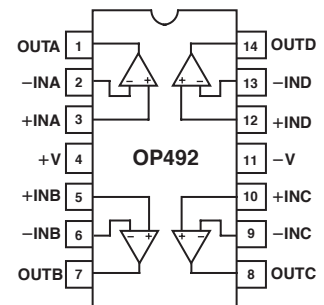

OP292/OP492—SPECIFICATIONS

ELECTRICAL CHARACTERISTICS (@ $V_S = 5\text{ V}$, $V_{CM} = 0\text{ V}$, $V_O = 2\text{ V}$, $T_A = 25^\circ\text{C}$ unless otherwise noted.)

| Parameter | Symbol | Conditions | Min | Typ | Max | Unit |
|--|--------------------------|---|-----|------|-----|------------------------------|
| INPUT CHARACTERISTICS | | | | | | |
| Offset Voltage OP292 | V_{OS} | $-40^\circ\text{C} \leq T_A \leq +85^\circ\text{C}$ | | 0.1 | 0.8 | mV |
| | | $-40^\circ\text{C} \leq T_A \leq +125^\circ\text{C}$ | | 0.3 | 1.2 | mV |
| Offset Voltage OP492 | V_{OS} | $-40^\circ\text{C} \leq T_A \leq +85^\circ\text{C}$ | | 0.5 | 2.5 | mV |
| | | $-40^\circ\text{C} \leq T_A \leq +125^\circ\text{C}$ | | 0.1 | 1 | mV |
| Input Bias Current | I_B | $-40^\circ\text{C} \leq T_A \leq +85^\circ\text{C}$ | | 0.3 | 1.5 | mV |
| | | $-40^\circ\text{C} \leq T_A \leq +125^\circ\text{C}$ | | 0.5 | 2.5 | mV |
| Input Offset Current | I_{OS} | $-40^\circ\text{C} \leq T_A \leq +85^\circ\text{C}$ | | 450 | 700 | nA |
| | | $-40^\circ\text{C} \leq T_A \leq +125^\circ\text{C}$ | | 0.75 | 2.5 | μA |
| Input Voltage Range Common-Mode Rejection Ratio | CMRR | $-40^\circ\text{C} \leq T_A \leq +125^\circ\text{C}$ | | 3.0 | 5.0 | μA |
| | | $-40^\circ\text{C} \leq T_A \leq +85^\circ\text{C}$ | | 7 | 50 | nA |
| Input Voltage Range Common-Mode Rejection Ratio | CMRR | $-40^\circ\text{C} \leq T_A \leq +85^\circ\text{C}$ | | 100 | 700 | nA |
| | | $-40^\circ\text{C} \leq T_A \leq +125^\circ\text{C}$ | | 0.4 | 1.2 | μA |
| Large-Signal Voltage Gain | A_{VO} | $V_{CM} = 0\text{ V to } 4.0\text{ V}$ | 0 | | 4.0 | V |
| | | $-40^\circ\text{C} \leq T_A \leq +85^\circ\text{C}$ | 75 | 95 | | dB |
| Large-Signal Voltage Gain | A_{VO} | $-40^\circ\text{C} \leq T_A \leq +125^\circ\text{C}$ | 70 | 93 | | dB |
| | | $R_L = 10\text{ k}\Omega$, $V_O = 0.1\text{ V to } 4\text{ V}$ | 65 | 90 | | dB |
| Offset Voltage Drift Long-Term V_{OS} Drift | $\Delta V_{OS}/\Delta T$ | $-40^\circ\text{C} \leq T_A \leq +85^\circ\text{C}$ | 25 | 200 | | V/mV |
| | | $-40^\circ\text{C} \leq T_A \leq +125^\circ\text{C}$ | 10 | 100 | | V/mV |
| Bias Current Drift | $\Delta I_B/\Delta T$ | $-40^\circ\text{C} \leq T_A \leq +125^\circ\text{C}$ | 5 | 50 | | V/mV |
| | | Note 1 | | 2 | 10 | $\mu\text{V}/^\circ\text{C}$ |
| Offset Current Drift | $\Delta I_{OS}/\Delta T$ | $-40^\circ\text{C} \leq T_A \leq +85^\circ\text{C}$ | | 1 | | $\mu\text{V}/\text{Month}$ |
| | | $-40^\circ\text{C} \leq T_A \leq +125^\circ\text{C}$ | | 6 | | $\text{pA}/^\circ\text{C}$ |
| Offset Current Drift | $\Delta I_{OS}/\Delta T$ | $-40^\circ\text{C} \leq T_A \leq +85^\circ\text{C}$ | | 400 | | $\text{pA}/^\circ\text{C}$ |
| | | $-40^\circ\text{C} \leq T_A \leq +125^\circ\text{C}$ | | 1.5 | | $\text{pA}/^\circ\text{C}$ |
| Offset Current Drift | $\Delta I_{OS}/\Delta T$ | $-40^\circ\text{C} \leq T_A \leq +85^\circ\text{C}$ | | 2 | | $\text{pA}/^\circ\text{C}$ |
| | | $-40^\circ\text{C} \leq T_A \leq +125^\circ\text{C}$ | | 2 | | $\text{pA}/^\circ\text{C}$ |
| OUTPUT CHARACTERISTICS | | | | | | |
| Output Voltage Swing High | V_{OUT} | $R_L = 100\text{ k}\Omega$ to GND | | | | |
| | | $-40^\circ\text{C} \leq T_A \leq +125^\circ\text{C}$ | 4.0 | 4.3 | | V |
| Output Voltage Swing Low | V_{OUT} | $R_L = 2\text{ k}\Omega$ to GND | | | | |
| | | $-40^\circ\text{C} \leq T_A \leq +125^\circ\text{C}$ | 3.8 | 4.1 | | V |
| Short-Circuit Current Limit | I_{SC} | $R_L = 100\text{ k}\Omega$ to V+ | | | | |
| | | $-40^\circ\text{C} \leq T_A \leq +125^\circ\text{C}$ | 3.7 | 3.9 | | V |
| Short-Circuit Current Limit | I_{SC} | $R_L = 2\text{ k}\Omega$ to V+ | | | | |
| | | $-40^\circ\text{C} \leq T_A \leq +125^\circ\text{C}$ | | 8 | 20 | mV |
| Short-Circuit Current Limit | I_{SC} | $R_L = 100\text{ k}\Omega$ to V+ | | | | |
| | | $-40^\circ\text{C} \leq T_A \leq +125^\circ\text{C}$ | | 12 | 20 | mV |
| Short-Circuit Current Limit | I_{SC} | $R_L = 2\text{ k}\Omega$ to V+ | | | | |
| | | $-40^\circ\text{C} \leq T_A \leq +125^\circ\text{C}$ | | 280 | 450 | mV |
| Short-Circuit Current Limit | I_{SC} | $R_L = 100\text{ k}\Omega$ to GND | | | | |
| | | $-40^\circ\text{C} \leq T_A \leq +125^\circ\text{C}$ | 5 | 8 | 550 | mV |
| Short-Circuit Current Limit | I_{SC} | $R_L = 2\text{ k}\Omega$ to GND | | | | |
| | | $-40^\circ\text{C} \leq T_A \leq +125^\circ\text{C}$ | | 8 | | mA |
| POWER SUPPLY | | | | | | |
| Power Supply Rejection Ratio | PSRR | $V_S = 4.5\text{ V to } 30\text{ V}$, $V_O = 2\text{ V}$ | 75 | 95 | | dB |
| | | $-40^\circ\text{C} \leq T_A \leq +125^\circ\text{C}$ | 70 | 90 | | dB |
| Supply Current Per Amp OP292, OP492 | I_{SY} | $V_O = 2\text{ V}$ | | 0.8 | 1.2 | mA |
| DYNAMIC PERFORMANCE | | | | | | |
| Slew Rate | SR | $R_L = 10\text{ k}\Omega$ | | | | |
| | | $-40^\circ\text{C} \leq T_A \leq +125^\circ\text{C}$ | 1 | 3 | | V/ μs |
| Gain Bandwidth Product | GBP | | | 2 | | V/ μs |
| Phase Margin | ϕ_m | | | 4 | | MHz |
| Channel Separation | CS | $f_0 = 1\text{ kHz}$ | | 75 | | Degrees |
| Channel Separation | CS | $f_0 = 1\text{ kHz}$ | | 100 | | dB |
| NOISE PERFORMANCE | | | | | | |
| Voltage Noise | e_n p-p | 0.1 Hz to 10 Hz | | 25 | | $\mu\text{V p-p}$ |
| Voltage Noise Density | e_n | $f = 1\text{ kHz}$ | | 15 | | $\text{nV}/\sqrt{\text{Hz}}$ |
| Current Noise Density | i_n | | | 0.7 | | $\text{pA}/\sqrt{\text{Hz}}$ |

NOTES

¹Long-term offset voltage drift is guaranteed by 1,000 hours life test performed on three independent wafer lots at 125°C with LTPD of 1.3.

Specifications subject to change without notice.

ELECTRICAL CHARACTERISTICS (@ $V_S = 5\text{ V}$, $V_{CM} = 0\text{ V}$, $V_O = 2\text{ V}$, $T_A = 25^\circ\text{C}$ unless otherwise noted.)

| Parameter | Symbol | Conditions | Min | Typ | Max | Unit |
|--|---|--|------------|------------|-----|------------------------------|
| INPUT CHARACTERISTICS | | | | | | |
| Offset Voltage OP292 | V_{OS} | $-40^\circ\text{C} \leq T_A \leq +85^\circ\text{C}$ | | 1.0 | 2.0 | mV |
| | | $-40^\circ\text{C} \leq T_A \leq +125^\circ\text{C}$ | | 1.2 | 2.5 | mV |
| Offset Voltage OP492 | V_{OS} | $-40^\circ\text{C} \leq T_A \leq +85^\circ\text{C}$ | | 1.5 | 3 | mV |
| | | $-40^\circ\text{C} \leq T_A \leq +125^\circ\text{C}$ | | 1.4 | 2.5 | mV |
| Input Bias Current | I_B | $-40^\circ\text{C} \leq T_A \leq +85^\circ\text{C}$ | | 1.7 | 2.8 | mV |
| | | $-40^\circ\text{C} \leq T_A \leq +125^\circ\text{C}$ | | 2 | 3 | mV |
| Input Offset Current | I_{OS} | $-40^\circ\text{C} \leq T_A \leq +85^\circ\text{C}$ | | 375 | 700 | nA |
| | | $-40^\circ\text{C} \leq T_A \leq +125^\circ\text{C}$ | | 0.5 | 1 | μA |
| Input Voltage Range Common-Mode Rejection Ratio | CMRR | $-40^\circ\text{C} \leq T_A \leq +85^\circ\text{C}$ | | 7 | 50 | nA |
| | | $-40^\circ\text{C} \leq T_A \leq +125^\circ\text{C}$ | | 20 | 100 | nA |
| Large-Signal Voltage Gain | A_{VO} | Note 1 | -11 | | 11 | V |
| | | $V_{CM} = \pm 11\text{ V}$ | 78 | 100 | | dB |
| Offset Voltage Drift Bias Current Drift | $\Delta V_{OS}/\Delta T$ $\Delta I_B/\Delta T$ | $-40^\circ\text{C} \leq T_A \leq +85^\circ\text{C}$ | | 75 | 95 | dB |
| | | $-40^\circ\text{C} \leq T_A \leq +125^\circ\text{C}$ | | 25 | 120 | V/mV |
| Offset Voltage Drift Bias Current Drift | $\Delta V_{OS}/\Delta T$ $\Delta I_B/\Delta T$ | $-40^\circ\text{C} \leq T_A \leq +85^\circ\text{C}$ | | 10 | 75 | V/mV |
| | | $-40^\circ\text{C} \leq T_A \leq +125^\circ\text{C}$ | | 5 | 60 | V/mV |
| Offset Voltage Drift Bias Current Drift | $\Delta V_{OS}/\Delta T$ $\Delta I_B/\Delta T$ | $-40^\circ\text{C} \leq T_A \leq +125^\circ\text{C}$ | | 4 | 10 | $\mu\text{V}/^\circ\text{C}$ |
| | | $-40^\circ\text{C} \leq T_A \leq +125^\circ\text{C}$ | | 3 | | $\text{pA}/^\circ\text{C}$ |
| OUTPUT CHARACTERISTICS | | | | | | |
| Output Voltage Swing | V_O | $R_L = 2\text{ k}\Omega$ to GND | ± 11 | ± 12.2 | | V |
| | | $-40^\circ\text{C} \leq T_A \leq +125^\circ\text{C}$ | ± 10 | ± 11 | | V |
| Short-Circuit Current Limit | I_{SC} | $R_L = 100\text{ k}\Omega$ to GND | ± 13.8 | ± 14.3 | | V |
| | | $-40^\circ\text{C} \leq T_A \leq +125^\circ\text{C}$ | ± 13.5 | ± 14.0 | | mV |
| Short-Circuit Current Limit | I_{SC} | Short Circuit to GND | 8 | 10.5 | | mA |
| | | | | | | |
| POWER SUPPLY | | | | | | |
| Power Supply Rejection Ratio | PSRR | $V_S = \pm 2.25\text{ V}$ to $\pm 15\text{ V}$ | 75 | 86 | | dB |
| | | $40^\circ\text{C} \leq T_A \leq +125^\circ\text{C}$ | 70 | 83 | | dB |
| Supply Current Per Amp OP292, OP492 | I_{SY} | $V_O = 0\text{ V}$ | | 1 | 1.4 | mA |
| DYNAMIC PERFORMANCE | | | | | | |
| Slew Rate | | SR $R_L = 10\text{ k}\Omega$ | 2.5 | 4 | | V/ μs |
| | | $-40^\circ\text{C} \leq T_A \leq +125^\circ\text{C}$ | 2 | 3 | | V/ μs |
| Gain Bandwidth Product | GBP | | | 4 | | MHz |
| Phase Margin | ϕ_m | | | 75 | | Degrees |
| Channel Separation | CS | $f_O = 1\text{ k Hz}$ | | 100 | | dB |
| NOISE PERFORMANCE | | | | | | |
| Voltage Noise | e_n p-p | 0.1 Hz to 10 Hz | | 25 | | $\mu\text{V p-p}$ |
| Voltage Noise Density | e_n | $f = 1\text{ k Hz}$ | | 15 | | $\text{nV}/\sqrt{\text{Hz}}$ |
| Current Noise Density | i_n | | | 0.7 | | $\text{pA}/\sqrt{\text{Hz}}$ |

NOTES

¹Input voltage range is guaranteed by CMRR tests.

Specifications subject to change without notice.

OP292/OP492

ABSOLUTE MAXIMUM RATINGS¹

| | |
|--|-----------------|
| Supply Voltage | 33 V |
| Input Voltage ² | -15 V to +14 V |
| Differential Input Voltage ² | V |
| Output Short-Circuit Duration | UNLIMITED |
| Storage Temperature Range | |
| P, S Package | -65°C to +150°C |
| Operating Temperature Range | |
| OP292/OP492 P, S | -40°C to +125°C |
| Junction Temperature Range | |
| P, S Package | -65°C to +125°C |
| Lead Temperature Range (Soldering, 60 sec) | 300°C |

| Package Type | θ_{JA} ³ | θ_{JC} | Unit |
|------------------------|----------------------------|---------------|------|
| 8-Pin Plastic DIP (P) | 103 | 43 | °C/W |
| 14-Pin Plastic DIP (P) | 83 | 39 | °C/W |
| 8-Pin SOIC (S) | 158 | 43 | °C/W |
| 14-Pin SOIC (S) | 120 | 36 | °C/W |

NOTES

¹Absolute maximum ratings apply to both DICE and packaged parts, unless otherwise noted.

²For supply voltages less than 36 V, the absolute maximum input voltage is equal to the supply voltage.

³ θ_{JA} is specified for the worst-case conditions, i.e., θ_{JA} is specified for device in socket for P-DIP package; θ_{JA} is specified for device soldered in circuit board for SOIC package.

ORDERING GUIDE

| Model | Temperature Range | Package Option |
|----------|-------------------|----------------|
| OP292GP* | -40°C to +125°C | N-8 |
| OP292GS | -40°C to +125°C | RN-8 |
| OP492GP* | -40°C to +125°C | N-14 |
| OP492GS | -40°C to +125°C | RN-14 |

*Not for new design, obsolete April 2002.

Typical Performance Characteristics—OP292/OP492

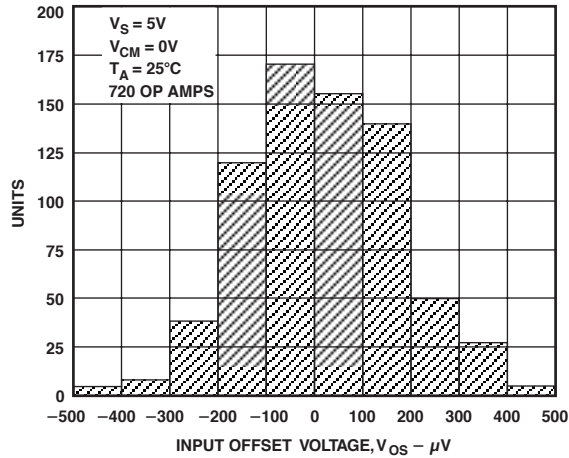

TPC 1. OP292 Input Offset Voltage Distribution @ 5 V

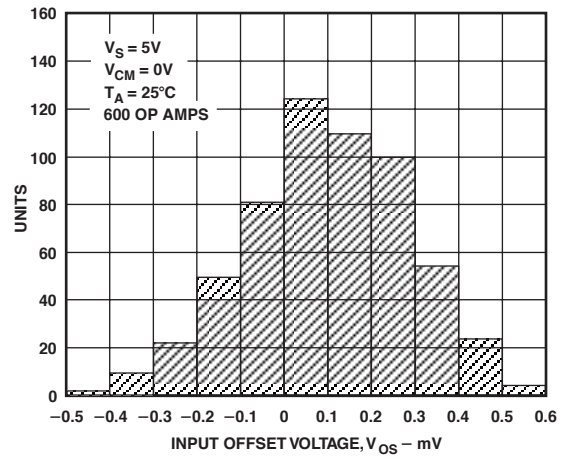

TPC 4. OP492 Input Offset Voltage Distribution @ 5 V

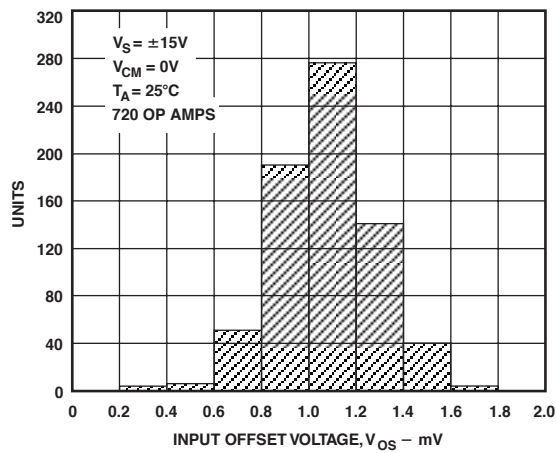

TPC 2. OP292 Input Offset Voltage Distribution @ ±15 V

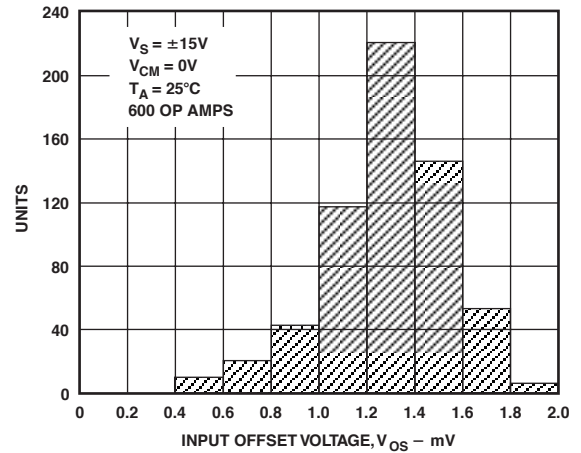

TPC 5. OP492 Input Offset Voltage Distribution @ ±15 V

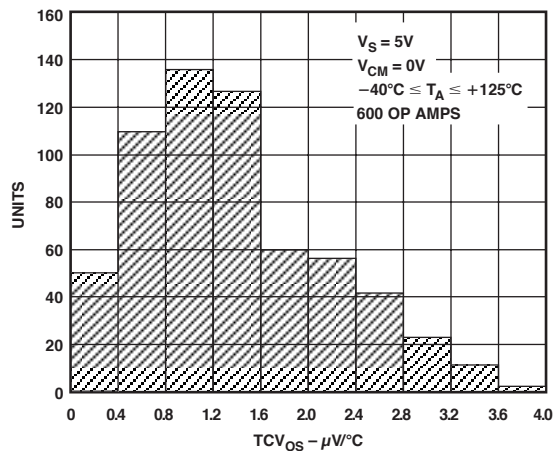

TPC 3. OP292 Temperature Drift (TCV_{OS}) Distribution @ 5 V

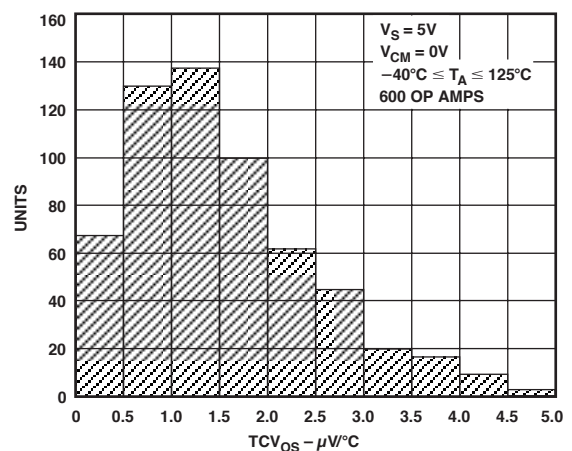

TPC 6. OP492 Temperature Drift (TCV_{OS}) Distribution @ 5 V

OP292/OP492

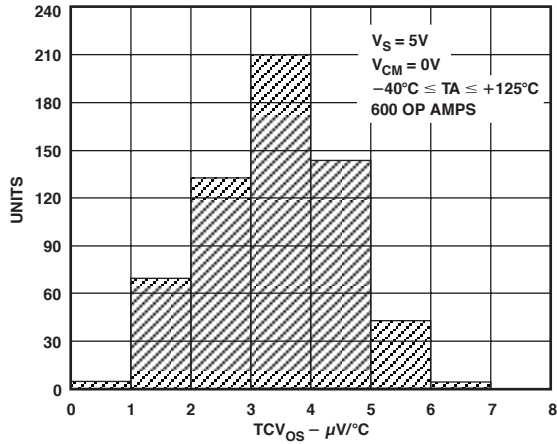

TPC 7. OP292 Temperature Drift (TCV_{OS}) Distribution @ $\pm 15V$

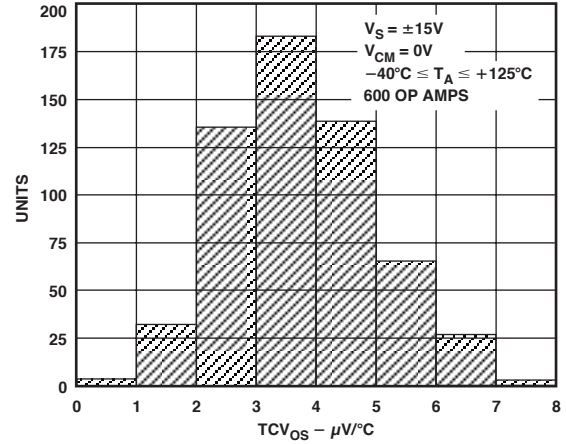

TPC 10. OP492 Temperature Drift (TCV_{OS}) Distribution @ $\pm 15V$

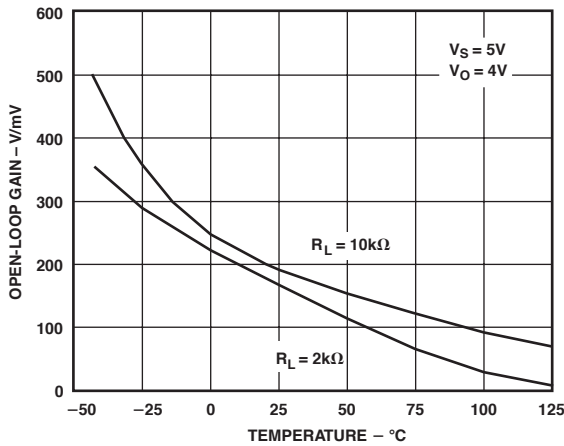

TPC 8. OP292 Open-Loop Gain vs. Temperature @ 5V

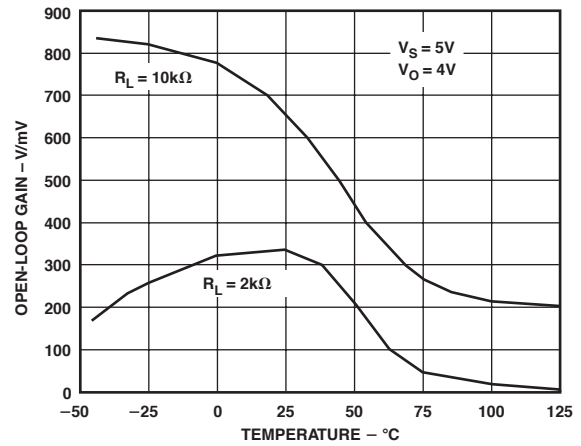

TPC 11. OP492 Open-Loop Gain vs. Temperature @ 5V

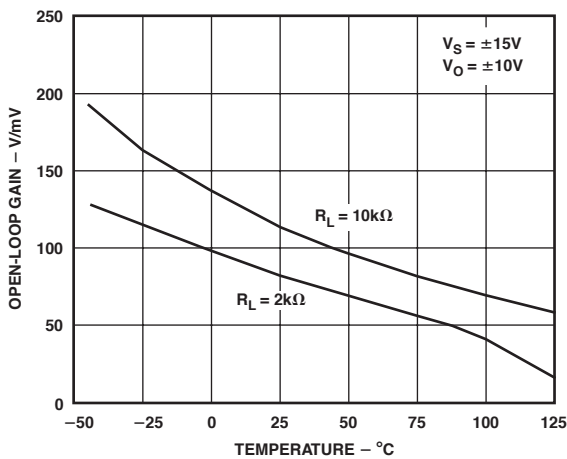

TPC 9. OP292 Open-Loop Gain vs. Temperature @ $\pm 15V$

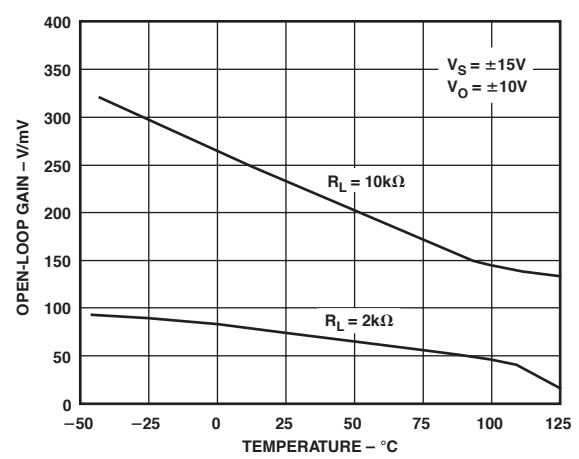

TPC 12. OP492 Open-Loop Gain vs. Temperature @ $\pm 15V$

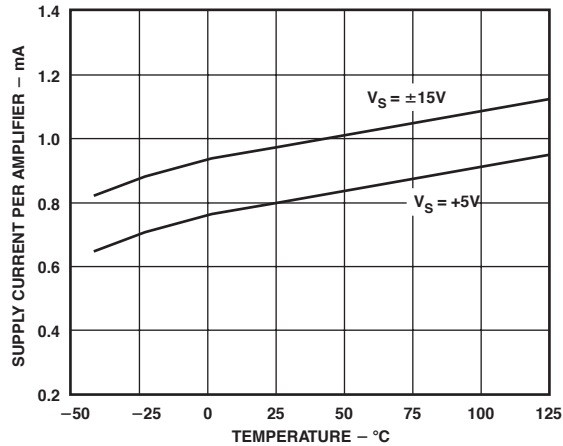

TPC 13. OP292 Supply Current per Amplifier vs. Temperature

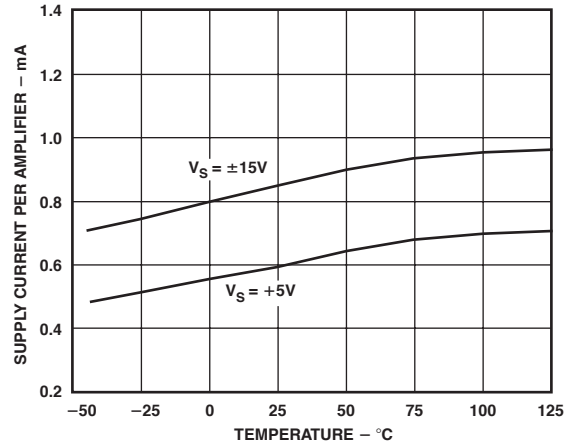

TPC 16. OP492 Supply Current per Amplifier vs. Temperature

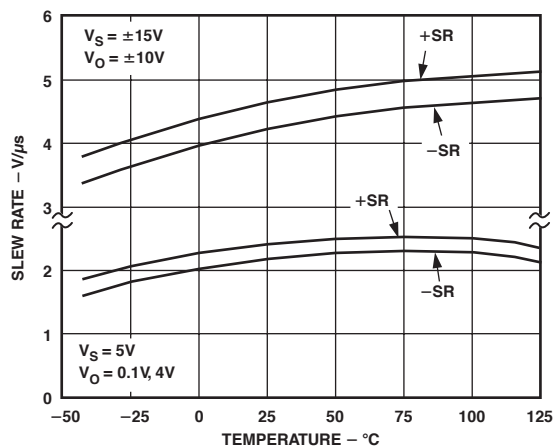

TPC 14. OP292 Slew Rate vs. Temperature

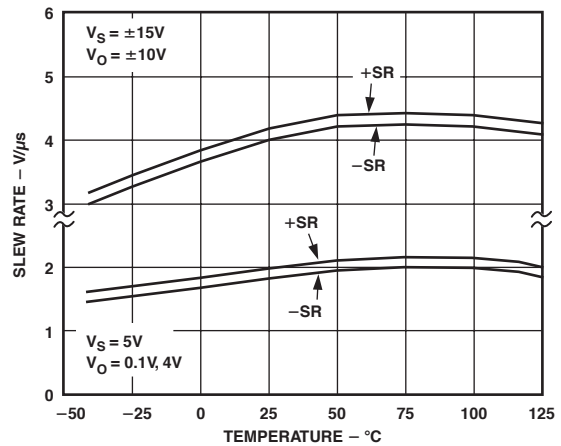

TPC 17. OP492 Slew Rate vs. Temperature

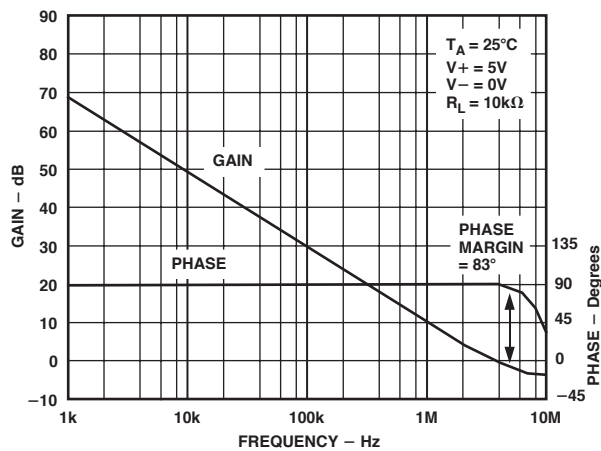

TPC 15. OP292/OP492 Open-Loop Gain and Phase vs. Frequency @ 5 V

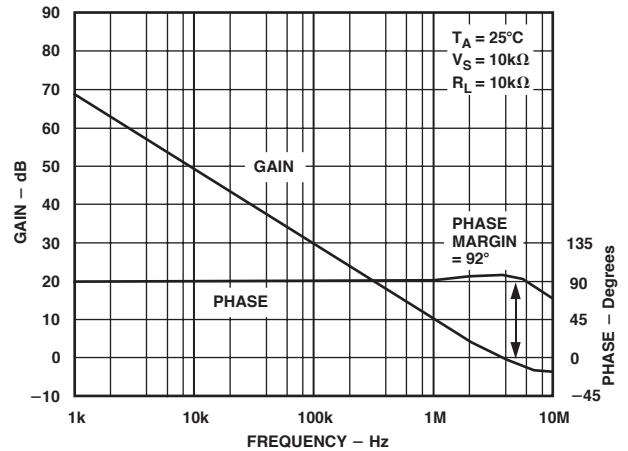

TPC 18. OP292/OP492 Open-Loop Gain/Phase vs. Frequency @ ±15 V

OP292/OP492

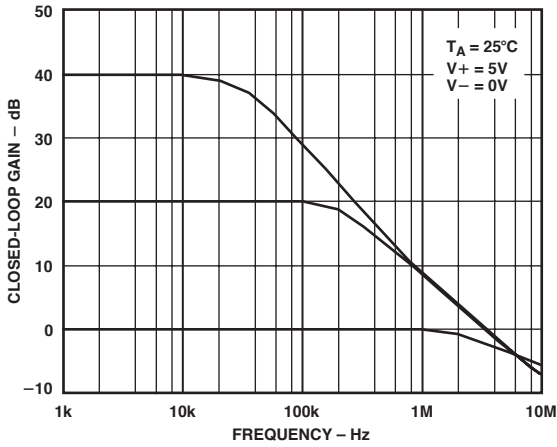

TPC 19. OP292/OP492 Closed-Loop Gain/Phase vs. Frequency @ 5 V

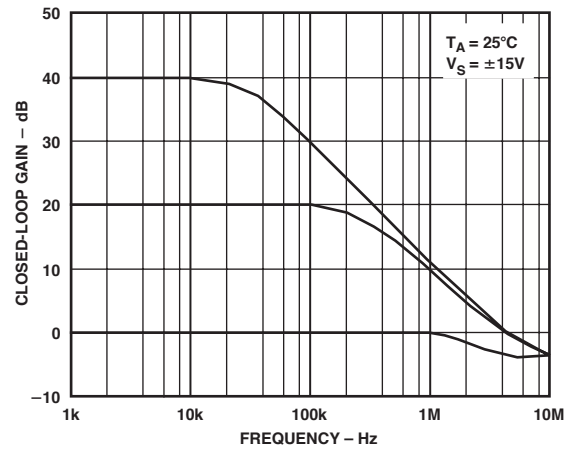

TPC 22. OP292/OP492 Closed-Loop Gain/Phase vs. Frequency @ $\pm 15\text{V}$

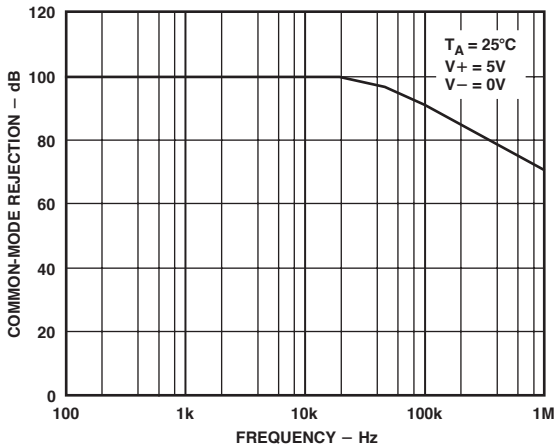

TPC 20. OP292/OP492 CMR vs. Frequency @ 5 V

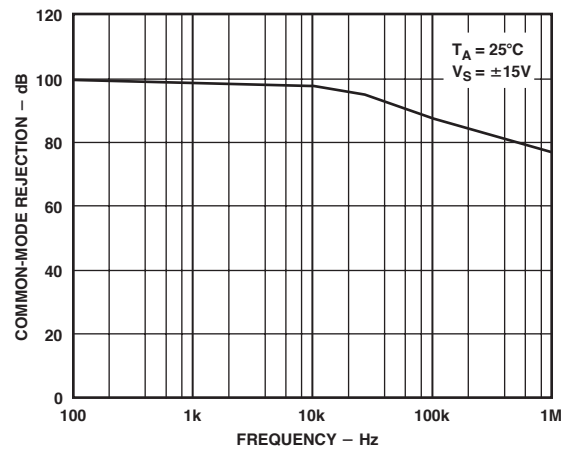

TPC 23. OP292/OP492 CMR vs. Frequency @ $\pm 15\text{V}$

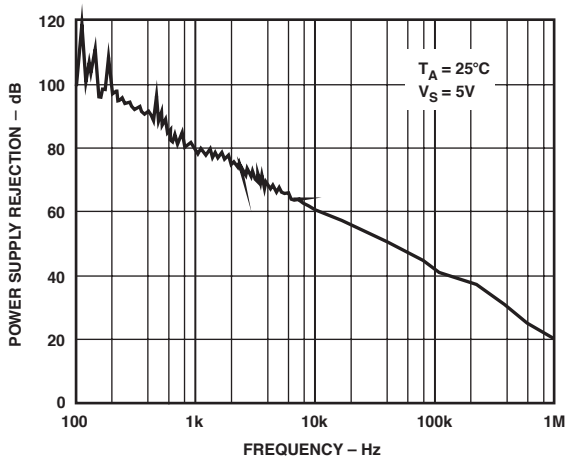

TPC 21. OP292/OP492 PSR vs. Frequency @ 5 V

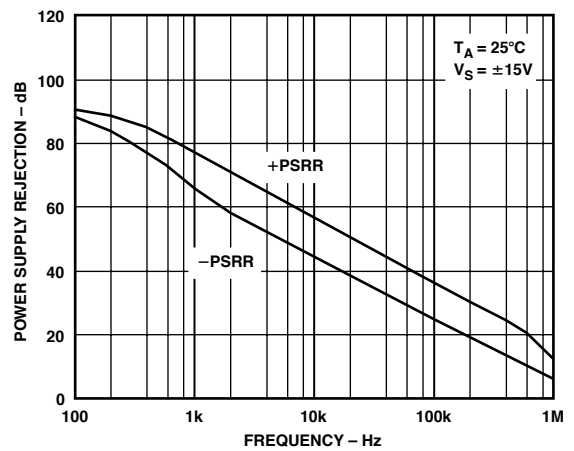

TPC 24. OP292/OP492 PSR vs. Frequency @ $\pm 15\text{V}$

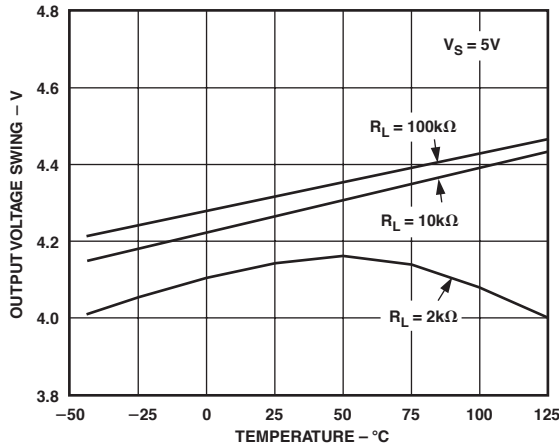

TPC 25. OP292/OP492 V_{OUT} Swing vs. Temperature @ 5 V

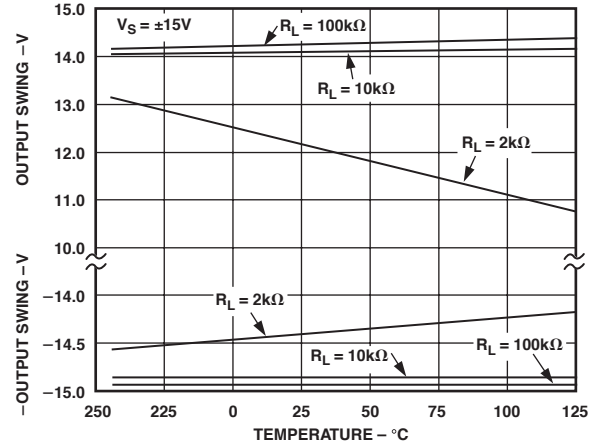

TPC 28. OP292/OP492 V_{OUT} Swing vs. Temperature @ $\pm 15 V$

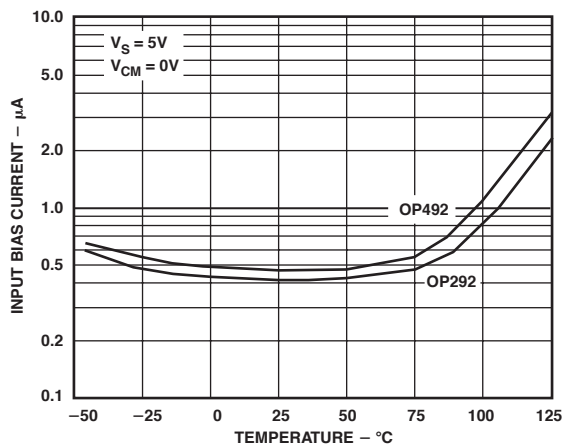

TPC 26. OP292/OP492 Input Bias Current vs. Temperature @ 5 V

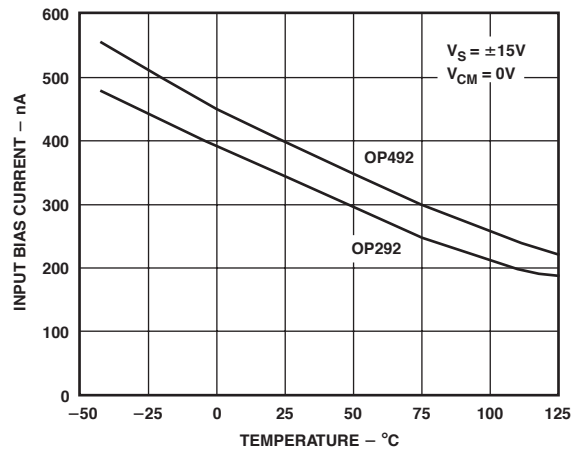

TPC 29. OP292/OP492 Input Bias Current vs. Temperature @ $\pm 15 V$

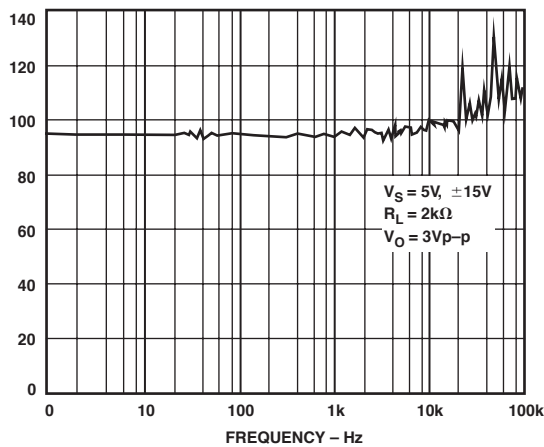

TPC 27. OP292/OP492 Channel Separation

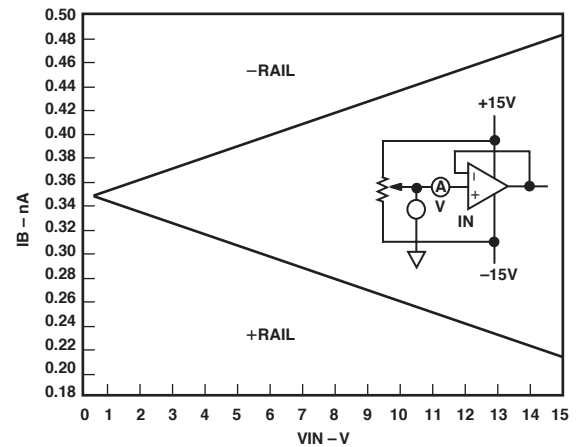

TPC 30. OP292/OP492 I_B Current vs. Common-Mode Voltage

OP292/OP492

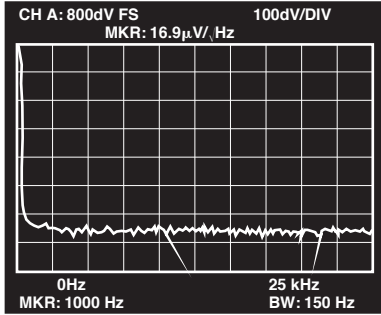

TPC 31. Voltage Noise Density

APPLICATION INFORMATION

Phase Reversal

The OP492 has built-in protection against phase reversal when the input voltage goes to either supply rail. In fact, it is safe for the input to exceed either supply rail by up to 0.6 V with no risk of phase reversal. However, the input should not go beyond the positive supply rail by more than 0.9 V, otherwise the output will reverse phase. If this condition can occur, the problem can be fixed by adding a 5 kΩ current limiting resistor in series with the input pin. With this addition, the input can go to more than 5 V beyond the positive rail without phase reversal.

An input voltage that is as much as 5 V below the negative rail will not result in phase reversal.

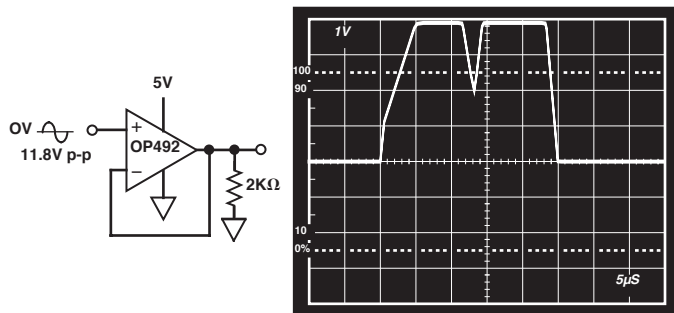

Figure 1. Output Phase Reverse If Input Exceeds the Positive Supply (V+) by More Than 0.9 V

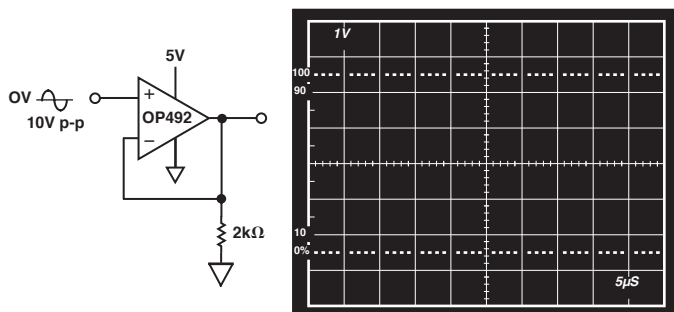

Figure 2. No Negative Rail Phase Reversal, Even with Input Signal at 5 V Below Ground

Power Supply Considerations

The OP292/OP492 are designed to operate equally well at single 5 V or ± 15 V supplies. The lowest supply voltage recommended is 4.5 V.

It is a good design practice to bypass the supply pins with a 0.1 μ F ceramic capacitor. It helps improve filtering of high frequency noise.

For dual supply operation, the negative supply (V-) must be applied at the same time, or before V+. If V+ is applied before V-, or in the case of a loss of V- supply, while either input is connected to ground or other low impedance source, excessive input current may result. Potentially damaging levels of input current can destroy the amplifier. If this condition can exist, simply add a 1 kΩ or larger resistor in series with the input to eliminate the problem.

TYPICAL APPLICATIONS

Direct Access Arrangement for Telephone Line Interface

Figure 3 shows a 5 V- only transmit/receive telephone line interface for a modem circuit. It allows full duplex transmission of modem signals on a transformer-coupled 600 V line in a differential manner. The transmit section gain can be set for the specific modem device output. Similarly the receive amplifier gain can be appropriately selected based on the modem device input requirements. The circuit operates on a single 5 V supply. The standard value resistors allow the use of a SIP-packaged resistor array; coupled with a quad op amp in a single package, this offers a compact, low part-count solution.

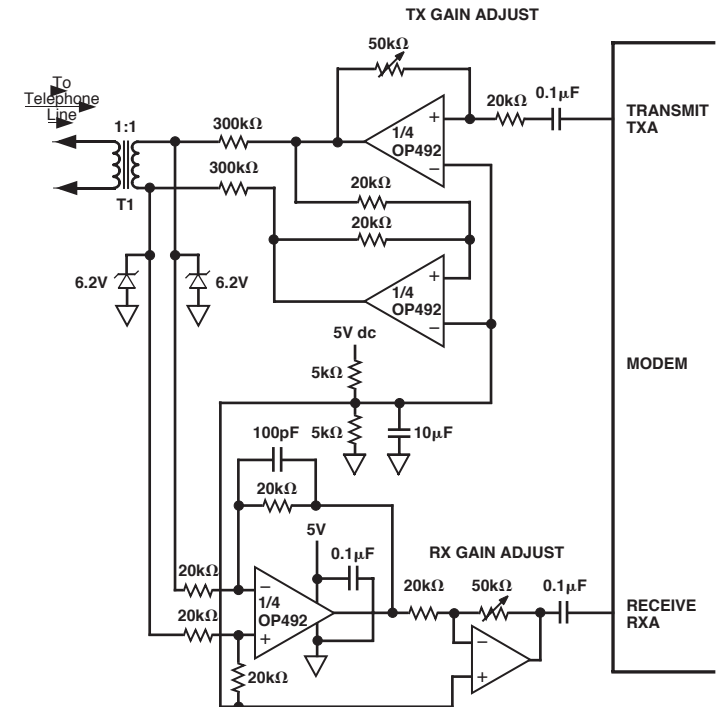

Figure 3. A Universal Direct Access Arrangement for Telephone Line Interface

A Single-Supply Instrumentation Amplifier

A low-cost, single-supply instrumentation amplifier can be built as shown in Figure 4. The circuit utilizes two op amps to form a high-input impedance differential amplifier. Gain can be set by selecting resistor R_G which can be calculated using the transfer function equation. Normally, $V_{REFERENCE}$ is set to 0 V. Then the output voltage is a function of the gain times the differential input

voltage. However, the output can be offset by setting $V_{\text{REFERENCE}}$ from 0 V to 4 V, as long as the input common-mode voltage of the amplifier is not exceeded.

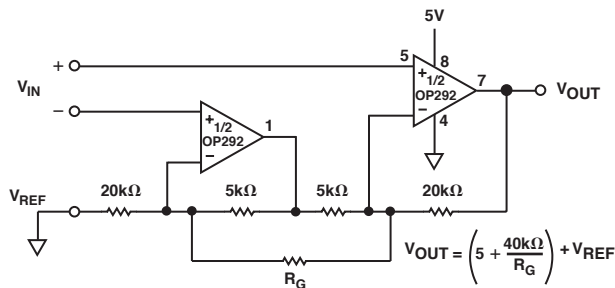

Figure 4. A Single-Supply Instrumentation Amplifier

In this configuration, while the output can swing to near zero volts, one needs to be careful because the input's common-mode voltage range cannot operate to zero volts. This is because of the limitation of the circuit configuration where the first amplifier must be able to swing below ground in order to attain a 0 V common-mode voltage, which it cannot do. Depending on the gain of the instrumentation amplifier, the input common-mode extends to within about 0.3 V of zero. One can easily calculate the worst-case common-mode limit for a given gain.

DAC Output Amplifier

The OP292/OP492 are ideal for buffering the output of single-supply D/A converters. Figure 5 shows a typical amplifier used to buffer the output of a CMOS DAC that is connected for single-supply operation. To do that, the normally current output 12-bit CMOS DAC (R-2R ladder type) is connected backward to produce a voltage output. This operating configuration necessitates a low voltage reference. In this case, a 1.235 V low-power reference is used. The relatively high output impedance (10 kΩ) is buffered by the OP292 and at the same time gained up to a much more usable level. The potentiometer provides an accurate gain trim for a 4.095 V full-scale, allowing 1mV increment per LSB of control resolution.

The DAC8043 device comes in an 8-pin DIP package providing a cost-effective, compact solution to a 12-bit analog channel.

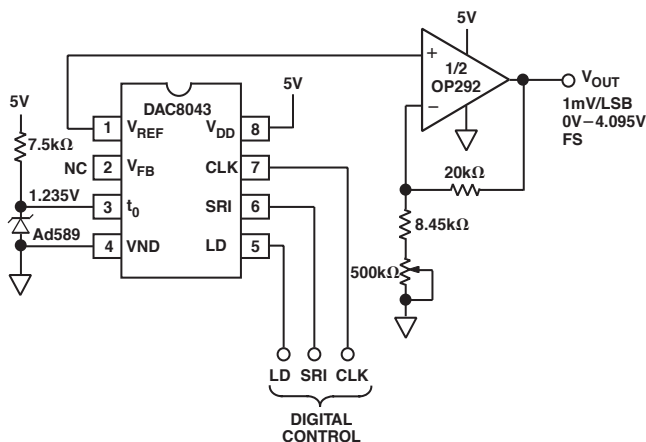
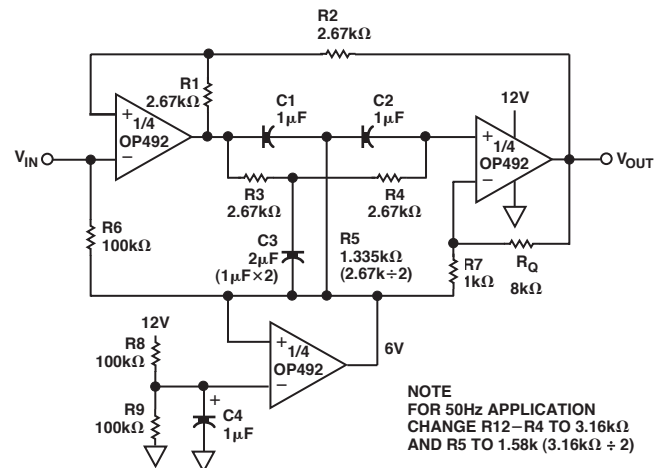

Figure 5. A 12-Bit Single-Supply DAC with Serial Bus Control

A 50 Hz/60 Hz Single-Supply Notch Filter

Figure 6 shows a notch filter that achieves nearly 30 dB of 60 Hz rejection while powered by only a single 12 V supply. The circuit also works well on 5 V systems. The filter utilizes a twin-T configuration whose frequency selectivity depends heavily on the relative matching of the capacitors and resistors in the twin-T section. Mylar is a good choice for the twin-T's capacitors, and the relative matching of the capacitors and resistors determines the filter's passband symmetry. Using 1% resistors and 5% capacitors produces satisfactory results.

The amount of rejection and the Q of the filter is solely determined by one resistor, and is shown in the table. The bottom amplifier is used to split the supply to bias the amplifier to midlevel. The circuit can be modified to reject 50 Hz by simply changing the resistors in the twin-T section (R1 through R4) from 2.67 kΩ to 3.16 kΩ, and changing R5 to 1/2 of 3.16 kΩ. For best results, the common value resistors can be from a resistor array for optimum matching characteristics.



| FILTER Q | R _Q (kΩ) | REJECTION (dB) | VOLTAGE GAIN |
|----------|---------------------|----------------|--------------|
| 0.75 | 1.0 | 40 | 1.33 |
| 1.00 | 2.0 | 35 | 1.50 |
| 1.25 | 3.0 | 30 | 1.60 |
| 2.50 | 8.0 | 25 | 1.80 |
| 5.00 | 18 | 20 | 1.90 |
| 10.00 | 38 | 15 | 1.95 |

Figure 6. A Single-Supply 50 Hz/60 Hz Notch Filter

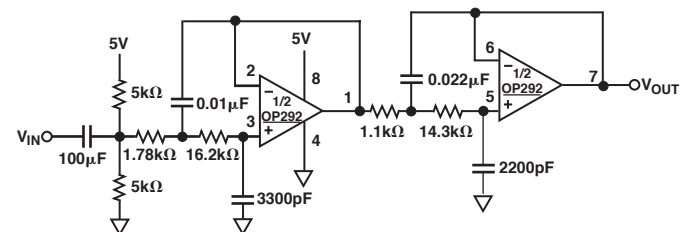

Figure 7. A 4-Pole Bessel Low-Pass Filter Using Sallen-Key Topology

A 4-Pole Bessel Low-Pass Filter

The linear phase filter in Figure 7 is designed to roll off at a voiceband cutoff frequency of 3.6 kHz. The 4 poles are formed by two cascading stages of two-pole Sallen-Key filters.

OP292/OP492

A Low-Cost, Linearized Thermistor Amplifier

An inexpensive thermometer amplifier circuit can be implemented using low-cost thermistors. One such implementation is shown in Figure 8. The circuit measures temperature over the range of 0°C to 70°C to an accuracy of ±0.3°C as the linearization circuit works well within a narrow temperature range. However, it can measure higher temperature but at a slightly reduced accuracy. To achieve the aforementioned accuracy, the thermistor's nonlinearity must be corrected. This is done by connecting the thermistor in parallel with the 10 kΩ in the feedback loop of the first stage amplifier. A constant operating current of 281 μA is supplied by the resistor R1 with the 5 V reference from the REF-195 such that the thermistor's self-heating error is kept below 0.1°C.

In many cases, the thermistor is placed some distance from the signal conditioning circuit. Under this condition, a 0.1 μF capacitor placed across R2 will help to suppress noise pickup.

This linearization network creates an offset voltage that is corrected by summing a compensating current with potentiometer P1. The temperature dependent signal is amplified by the second stage, producing a transfer coefficient of -10 mV/°C at the output.

To calibrate, a precision decade box can be used in place of the thermistor. For 0°C trim, the decade box is set to 32.650 kΩ, and P1 is adjusted until the circuit's output reads 0 V. To trim the circuit at the full-scale temperature of 70°C, the decade box is then set to 1.752 kΩ and P2 is adjusted until the circuit reads -0.70 V.

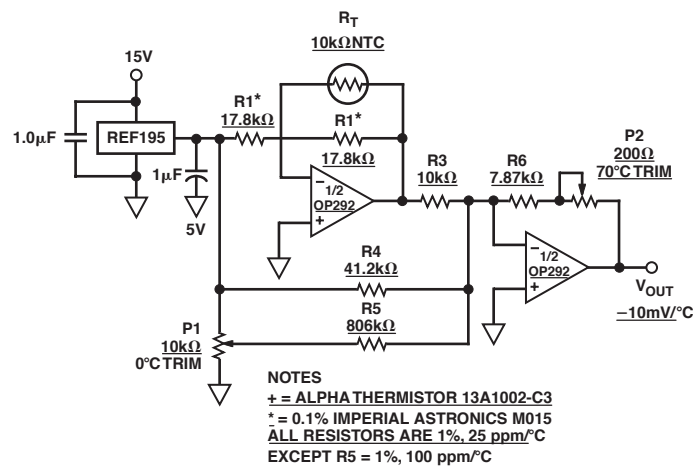

Figure 8. A Low Cost Linearized Thermistor Amplifier

A Single-Supply Ultrasonic Clamping/Limiting Receiver Amplifier

Figure 9 shows an ultrasonic receiver amplifier using the non-linear impedance of low-cost diodes to effectively control the gain for wide dynamic range. This circuit amplifies a 40 kHz ultrasonic signal through a pair of low-cost clamping amplifiers before feeding a band-pass filter to extract a clean 40 kHz signal for processing.

The signal is ac-coupled into the false-ground bias node by virtue of the capacitive piezoelectric sensing element. Rather than using an amplifier to generate a supply splitting bias, the false ground voltage is generated by a low-cost resistive voltage divider.

Each amplifier stage provides ac gain while passing on the dc self-bias. As long as the output signal at each stage is less than a diode's forward voltage, each amplifier has unrestricted gain to amplify low level signals. However, as the signal strength increases, the

feedback diodes begin to conduct, shunting the feedback current, and thus reducing the gain. Although distorting the waveform, the diodes effectively maintain a relatively constant amplitude even with large signals that otherwise would saturate the amplifier. In addition, this design is considerably more stable than the feedback type AGC.

The overall circuit has a gain range from -2 to -400, where the inversion comes from the band-pass filter stage. Operating with a Q of 5, the filter restores a clean, undistorted signal to the output. The circuit also works well with 5 V supply systems.

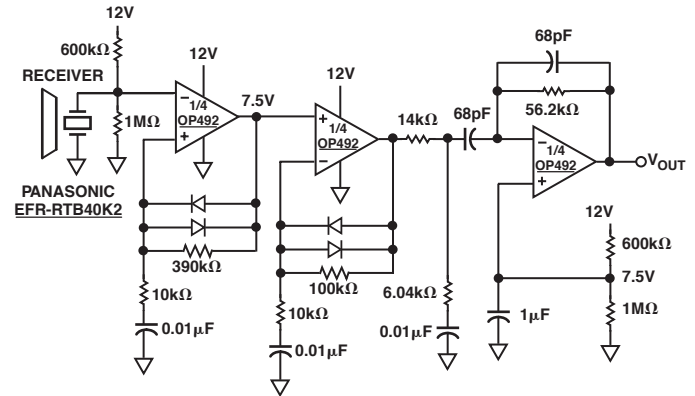

Figure 9. A 40 kHz Ultrasonic Clamping/Limiting Receiver Amplifier

Precision Single-Supply Voltage Comparator

The OP292/OP492 have excellent overload recovery characteristics, making them suitable for precision comparator applications. Figure 10 shows the saturation recovery characteristics of the OP492. The amplifier exhibits very little propagation delay. The amplifier compares a signal precisely to less than 0.5 mV offset error.

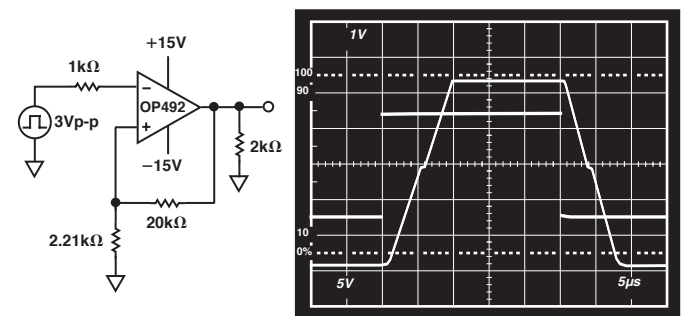

Figure 10. The OP492 Has Fast Overload Recovery for Comparator Applications

Programmable Precision Window Comparator

The OP292/OP492 can be used for precise level detection such as in test equipment where a signal is measured within a range. Figure 11 shows such an implementation. The threshold voltage level is set by a pair of 12-bit DIA converters. The DACs have serial interface thus minimizing interconnection requirements. The DAC85 12 has a control resolution of 1 mV/bit. Thus for 5 V supply operation, maximum DAC output is 4.095 V. However, the OP292 will accept a maximum input of 4.0 V.

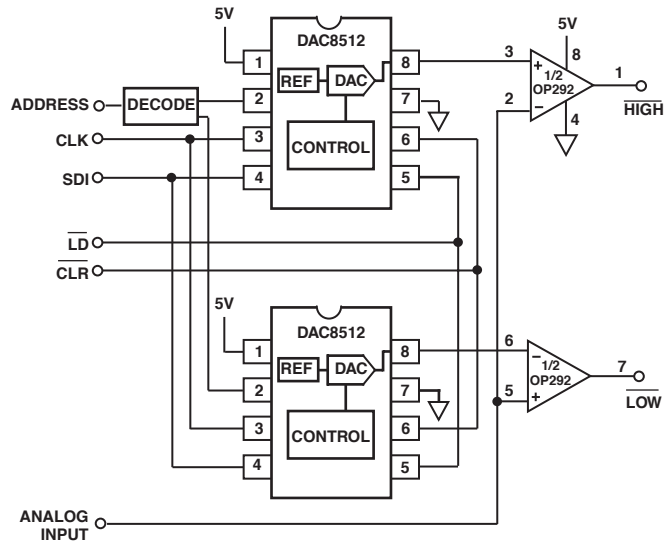

Figure 11. Programmable Window Comparator with 12-Bit Threshold Level Control

OP292/OP492

* OP292 SPICE Macro-model REV. B, 6/93
* ARG / PMI

* Copyright 1993 by Analog Devices

* Refer to "README.DOC" file for License Statement. Use of
* this model indicates your acceptance of the terms and provisions
* in the License Statement.

* Node assignments

| | | | | | |
|--|--------------------|-----------------|-----------------|-----------------|--------|
| | 2 | 1 | 99 | 50 | 34 |
| | noninverting input | inverting input | positive supply | negative supply | output |

.SUBCKT OP292 2 1 99 50 34

* INPUT STAGE AND POLE AT 40 MHz

| | | | |
|-----|----|----|---------------------------|
| Il | 99 | 4 | 5OE-6 |
| IOS | 2 | 1 | 10E-9 |
| EOS | 2 | 3 | POLY(1) (21,30) 1.5E-3 75 |
| CIN | 1 | 2 | 3E-12 |
| Q1 | 5 | 1 | 7 QP |
| Q2 | 6 | 3 | 8 QP |
| R3 | 5 | 50 | 2E3 |
| R4 | 6 | 50 | 2E3 |
| R5 | 4 | 7 | 966 |
| R6 | 4 | 8 | 966 |
| C1 | 5 | 6 | .995E12 |

* GAIN STAGE

| | | | |
|------|----|----|--------------|
| EREF | 98 | 0 | (30,0) 1 |
| G1 | 98 | 9 | (5,6) 50OE-6 |
| R7 | 9 | 98 | 210.819E3 |
| D1 | 9 | 10 | DX |
| D2 | 11 | 9 | DX |
| V1 | 99 | 10 | .6 |
| V2 | 11 | 50 | .6 |

* ZERO/POLE AT 6 MHz/12 MHz

| | | | |
|----|----|----|-----------|
| E1 | 12 | 98 | (9,30) 2 |
| R8 | 12 | 13 | 1 |
| R9 | 13 | 98 | 1 |
| C3 | 12 | 13 | 26.526E-9 |

* ZERO AT 15 MHz

| | | | |
|-----|----|----|-------------|
| E2 | 14 | 98 | (13,30) 1E6 |
| R10 | 14 | 15 | 1E6 |
| R11 | 15 | 98 | 1 |
| C4 | 14 | 15 | 10.610E-15 |

* COMMON-MODE STAGE WITH ZERO AT 40 kHz

| | | | |
|-----|----|----|---------------------------------|
| ECM | 20 | 98 | POLY(2) (1,30) (2,30) 0 0.5 0.5 |
| R20 | 20 | 21 | 1E6 |
| R21 | 21 | 98 | 1 |
| C5 | 20 | 21 | 3.979E-12 |

* POLE AT 100 MHz

*
G2 98 16 (15,30) 1
R12 16 98 1
C6 16 98 1.592E-9
*

* OUTPUT STAGE

*
RS1 99 30 1E6
RS2 30 50 1E6
ISY 99 50 .44E-3
G3 31 50 POLY(1) (16,30) -1.635E-6 4E-6
R16 31 50 1E6
DCL 50 31 DZ
I2 99 32 250E-6
RCL 33 50 56
M1 32 31 50 50 MN L=9E-6 W=1000E-6 AD=15E-9 AS=15E-9
M2 34 31 50 50 MN L=9E-6 W=1000E-6 AD=15E-9 AS=15E-9
CC 31 32 14E-12
Q3 99 32 34 QNA
Q4 33 32 34 QPA
Q5 31 33 50 QNA

.MODEL QNA NPN(IS=1.19E-16 BF=253 NF=0.99 VAF=193 IKF=2.76E-3
+ ISE=2.57E-13 NE=5 BR=0.4 NR=0.988 VAR=15 IKR=1.465E-4
+ ISC=6.9E-16 NC=0.99 RB=2.0E3 IRB=7.73E-6 RBM= 132.8 RE=4 RC=209
+ CJE=2.1E-13 VJE=0.573 MJE=0.364 FC=0.5 CJC=1.64E-13 VJC=0.534 MJC=0.5
+ CJS=1.37E-12 VJS=0.59 MJS=0.5 TF=0.43E-9 PTF=30)
.MODEL QPA PNP(IS=5.21E-17 BF=131 NF=0.99 VAF=62 IKF=8.35E-4
+ ISE= 1.09E-14 NE=2.61 BR=0.5 NR=0.984 VAR= 15 IKR=3.96E-5
+ ISC=7.58E-16 NC=0.985 RB=1.52E3 IRB=1.67E-5 RBM=368.5 RE=6.31 RC=354.4
+ CJE=1.1E-13 VJE=0.745 MJE=0.33 FC=0.5 CJC=2.37E-13 VJC=0.762 MJC=0.4
+ CJS=7.11E-13 VJS=0.45 MJS=0.412 TF=1.0E-9 PTF=30)
.MODEL MN NMOS(LEVEL=3 VTO=1.3 RS=0.3 RD=0.3
+ TOX=8.5E-8 LD=1.48E-6 WD=1E-6 NSUB=1.53E16 UO=650 DELTA=10 VMAX=2E5
+ XJ=1.75E-6 KAPPA=0.8 ETA=0.066 THETA=0.01 TPG=1 CJ=2.9E-4 PB=0.837
+ MJ=0.407 CJSW=0.5E-9 MJSW=0.33)
.MODEL QP PNP(BF=61.5)
.MODEL DX D
.MODEL DZ D(BV=3.6)
.ENDS OP292

OP292/OP492

* OP492 SPICE Macro-model REV. B, 6/93
* ARG / PMI
*
* Copyright 1993 by Analog Devices
*

* Refer to "README.DOC" file for License Statement. Use of
* this model indicates your acceptance of the terms and pro-
* visions in the License Statement.

* Node assignments

* noninverting input
* inverting input
* positive supply
* negative supply
* output

.SUBCKT OP492 2 1 99 50 34

* INPUT STAGE AND POLE AT 40 MHz

I1 99 4 50E-6
IOS 2 1 10E-9
EOS 2 3 POLY(1) (21,30) 1.5E-3 75
CIN 1 2 3E-12
Q1 5 1 7 QP
Q2 6 3 8 QP
R3 5 50 2E3
R4 6 50 2E3
R5 4 7 966
R6 4 8 966
C1 5 6 .995E-12

* GAIN STAGE

* EREF 98 0 (30,0) 1
G1 98 9 (5,6) 500E-6
R7 9 98 210.819E3
D1 9 10 DX
D2 11 9 DX
V1 99 10 .6
V2 11 50 .6

* ZERO/POLE AT 6 MHz/12 MHz

E1 12 98 (9,30) 2
R8 12 13 1
R9 13 98 1
C3 12 13 26.526E-9

* ZERO AT 15 MHz

E2 14 98 (13,30) 1E6
R10 14 15 1E6
R11 15 98 1
C4 14 15 10.610E-15

* COMMON-MODE STAGE WITH ZERO AT 40 kHz

ECM 20 98 POLY(2) (1,30) (2,30) 0 0.5 0.5
R20 20 21 1E6
R21 21 98 1
C5 20 21 3.979E-12

* POLE AT 100 MHz

*
G2 98 16 (15,30) 1
R12 16 98 1
C6 16 98 1.592E-9
*

* OUTPUT STAGE

*
RS1 99 30 1 E6
RS2 30 50 1E6
ISY 99 50 .44E-3
G3 31 50 POLY(1) (16,30) -1.635E-6 4E-6
R16 31 50 1E6
DCL 50 31 DZ
I2 99 32 250E-6
RCL 33 50 56
M1 32 31 50 50 MN L=9E-6 W=1000E-6 AD=15E-9 AS=15E-9
M2 34 31 50 50 MN L=9E-6 W=1000E-6 AD=15E-9 AS=15E-9
CC 31 32 14E-12
Q3 99 32 34 QNA
Q4 33 32 34 QPA
Q5 31 33 50 QNA

.MODEL QNA NPN(IS=1.19E-16 BF=253 NF=0.99 VAF=193 IKF=2.76E-3
+ ISE=2.57E-13 NE=5 BR=0.4 NR=0.988 VAR=15 IKR=1.465E-4
+ ISC=6.9E-16 NC=0.99 RB=2.0E3 IRB=7.73E-6 RBM=132.8 RE=4 RC=209
+ CJE=2.1E-13 VJE=0.573 MJE=0.364 FC=0.5 CJC=1.64E-13 VJC=0.534 MJC=0.5
+ CJS=1.37E-12 VJS=0.59 MJS=0.5 TF=0.43E-9 PTF=30)
.MODEL QPA PNP(IS=5.21E-17 BF=131 NF=0.99 VAF=62 IKF=8.35E-4
+ ISE=1.09E-14 NE=2.61 BR=0.5 NR=0.984 VAR=15 IKR=3.96E-5
+ ISC=7.58E-16 NC=0.985 RB=1.52E3 IRB=1.67E-5 RBM=368.5 RE=6.31 RC=354.4
+ CJE=1.1E-13 VJE=0.745 MJE=0.33 FC=0.5 CJC=2.37E-13 VJC=0.762 MJC=0.4
+ CJS=7.11E-13 VJS=0.45 MJS=0.412 TF=1.0E-9 PTF=30)
.MODEL MN NMOS(LEVEL=3 VTO=1.3 RS=0.3 RD=0.3
+ TOX=8.5E-8 LD=1.48E-6 WD=1E-6 NSUB=1.53E16 UO=650 DELTA=10 VMAX=2E5
+ XJ=1.75E-6 KAPPA=0.8 ETA=0.066 THETA=0.01 TPG=1 CJ=2.9E-4 PB=0.837
+ MJ=0.407 CJSW=0.5E-9 MJSW=0.33)
.MODEL QP PNP(BF=61.5)
.MODEL DX D
.MODEL DZ D(BV=3.6)
.ENDS OP492

OUTLINE DIMENSIONS

8-Lead Standard Small Outline Package [SOIC]
Narrow Body
(RN-8)

Dimensions shown in millimeters and (inches)

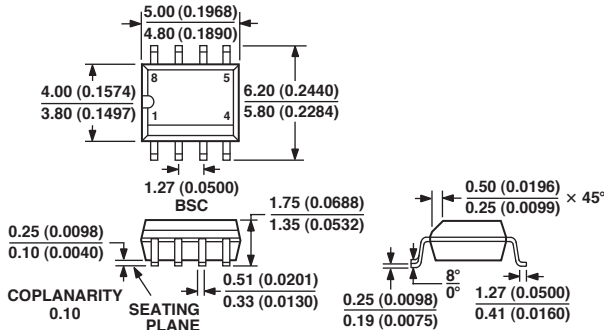

COMPLIANT TO JEDEC STANDARDS MS-012AA
CONTROLLING DIMENSIONS ARE IN MILLIMETERS; INCH DIMENSIONS (IN PARENTHESES) ARE ROUNDED-OFF MILLIMETER EQUIVALENTS FOR REFERENCE ONLY AND ARE NOT APPROPRIATE FOR USE IN DESIGN

8-Lead Plastic Dual-in-Line Package [PDIP]
(N-8)

Dimensions shown in inches and (millimeters)

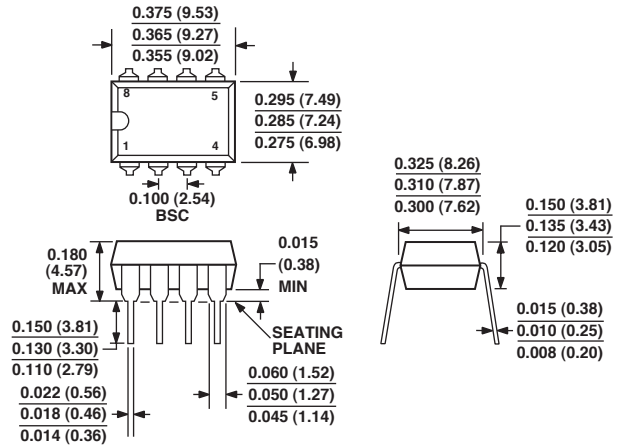

COMPLIANT TO JEDEC STANDARDS MO-095AA
CONTROLLING DIMENSIONS ARE IN INCHES; MILLIMETERS DIMENSIONS (IN PARENTHESES)

14-Lead Plastic Dual-in-Line Package [PDIP]
(N-14)

Dimensions shown in inches and (millimeters)

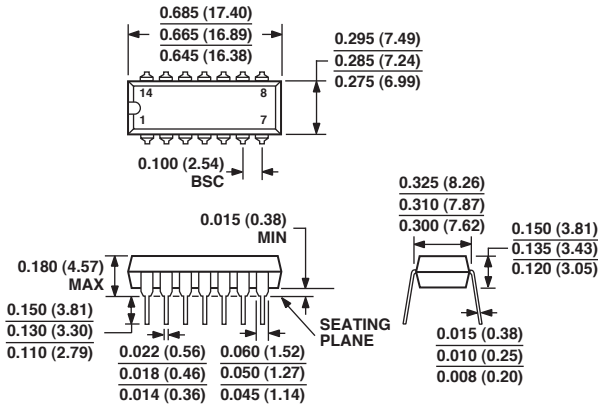

COMPLIANT TO JEDEC STANDARDS MO-095-AB
CONTROLLING DIMENSIONS ARE IN INCH; MILLIMETERS DIMENSIONS (IN PARENTHESES) ARE ROUNDED-OFF MILLIMETER EQUIVALENTS FOR REFERENCE ONLY AND ARE NOT APPROPRIATE FOR USE IN DESIGN

14-Lead Standard Small Outline Package [SOIC]
Narrow Body
(RN-14)

Dimensions shown in millimeters and (inches)

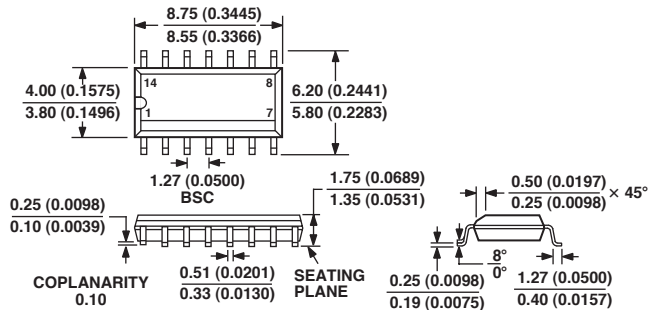

CONTROLLING DIMENSIONS ARE IN MILLIMETERS; INCH DIMENSIONS (IN PARENTHESES) ARE ROUNDED-OFF MILLIMETER EQUIVALENTS FOR REFERENCE ONLY AND ARE NOT APPROPRIATE FOR USE IN DESIGN

Revision History

| Location | Page |
|--------------------------------------|------|
| 10/02 - Change from Rev. A to REV. B | |
| Edits to OUTLINE DIMENSIONS | 18 |
| 1/02 - Change from Rev. 0 to REV. A | |
| Deleted Wafer Test Limits | 4 |
| Deleted DICE CHARACTERISTICS | 4 |
| Edits to ORDERING GUIDE | 4 |

