

TC9185P, TC9195P

T-77-21

Unit in mm

ELECTRONIC VOLUME CONTROLLER.

TC9185P and TC9195P are the controller exclusively developed for electronic volume IC TC9176P, TC9177P and TC9154P.

They are capable of making control of volume and balance, and indication of volume and balance by LED.

- TC9185P is used in combination with TC9176P or TC9177P, and is capable of making volume control of 40 steps, by 2dB step between 0dB ~ -76dB and $-\infty$, and balance control of up to -30dB, right and left.
- When combined with TC9177P, TC9185P is capable of ON/OFF control and indication of loudness.
- When combined with TC9154P, TC9195P is capable of making volume control of 35 steps, by 2dB step from 0dB to -66dB and $-\infty$, and balance control of up to -30dB right and left.
- The controller is capable of making bar type indication of LED 14 points for volume, and dot type indication of LED 13 points for balance, and has their built-in driver circuit.
- Because of C-MOS construction, memory back up of volume value and balance value at low consumption current is possible.

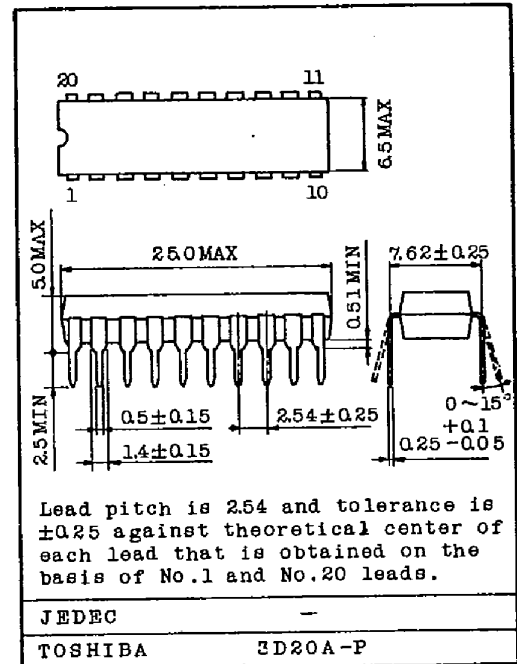

Weight : 1.4g

MAXIMUM RATINGS (Ta=25°C)

CHARACTERISTIC	SYMBOL	RATING	UNIT
Supply Voltage	V _{DD}	-0.3 ~ 7.0	V
Input Voltage	V _{IN}	-0.3 ~ V _{DD} +0.3	V
Output Current	I _{OH}	50	mA
Power Dissipation	P _D	350	mW
Operating Temperature	T _{opr}	-30 ~ 75	°C
Storage Temperature	T _{stg}	-55 ~ 125	°C

TERMINAL CONNECTION

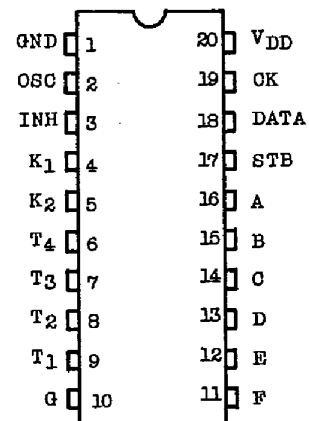

TC9185P, TC9195P

T-77-21

BLOCK DIAGRAM

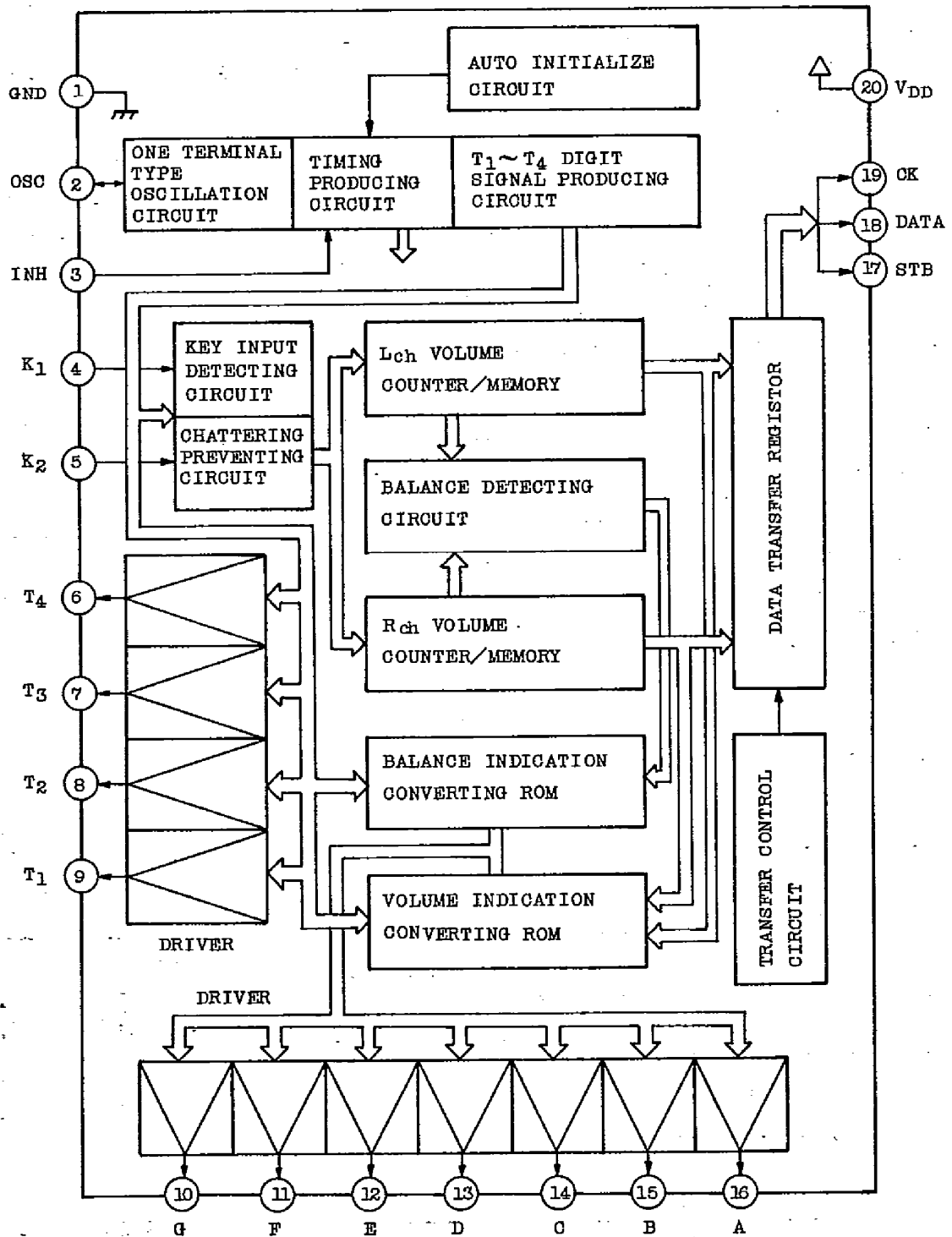

TC9185P, TC9195P

T-77-21

ELECTRICAL CHARACTERISTICS (Unless otherwise specified, $V_{DD}=5V$, $T_a=25^\circ C$)

CHARACTERISTIC	SYMBOL	TEST CIRCUIT	TEST CONDITION	MIN.	TYP.	MAX.	UNIT		
Operating Supply Voltage	V_{DD}	-	($T_a=-30 \sim 75^\circ C$)	4.0	5.0	6.0	V		
Operating Supply Current	I_{DD}	-	$f_{OSC}=100kHz$ No Load	-	0.5	1.2	mA		
Memory Backup Voltage	V_{DB}	-	INH=0V	2.5	~	6.0	V		
Inhibit Mode Supply Current	I_{DS}	-		-	-	-	10	μA	
Input Voltage	"H" Level	V_{IH}	INH, K_1 , K_2	$V_{DD} \times 0.7$	-	V_{DD}	V		
	"L" Level	V_{IL}		0	-	$V_{DD} \times 0.3$			
Input Current	"H" Level	I_{IH}	INH	$V_{IH}=5V$	-	-	± 1	μA	
	"L" Level	I_{IL}		$V_{IL}=0V$	-	-	± 1		
Pull Down Resistance	R_p	-	K_1 , K_2	-	22	-	k Ω		
Output Current (C-MOS)	"H" Level	I_{OH}	1	CK, DATA STB	$V_{OH}=4V$	1.0	2.0	-	mA
	"L" Level	I_{OL}			$V_{OL}=1V$	1.0	2.0	-	
Output Current (Bipolar)	"H" Level	I_{OH}	2	$T_1 \sim T_4$	$V_{OH}=4V$	20	30	-	mA
	"L" Level	I_{OL}		A ~ G	$V_{OL}=1V$	-	1.0	-	
OSC Oscillating Frequency	f_{OSC}	-	$R_x=47k\Omega$, $C_x=220pF$	-	100	-	kHz		
Operating Frequency	f_{OP}	-	$V_{DD}=4 \sim 6V$	-	100	500	kHz		
Auto Initialize Voltage	V_{INT}	-	Automatic Initialize Voltage	-	2.0	2.5	V		

MEASURING CIRCUIT

1. Output Current (C-MOS)

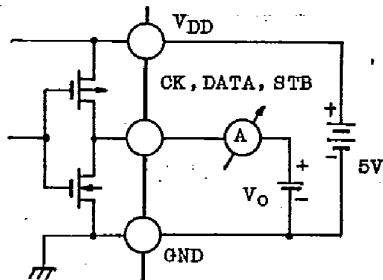

2. Output Current (Bipolar)

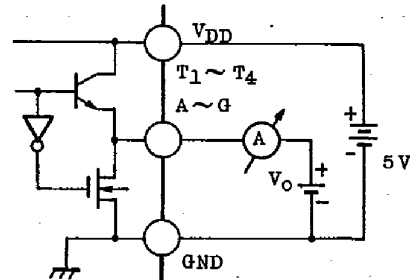

* I_{OH} : Output current when $V_O=V_{OH}$, with output terminal fixed at "H" level.

* I_{OL} : Output current when $V_O=V_{OL}$, with output terminal fixed at "L" level.

TC9185P, TC9195P

T-77-21

EXPLANATION OF FUNCTION OF EACH TERMINAL

TERMINAL NUMBER	NAME	EXPLANATION OF FUNCTION	REMARKS
1	GND	Supply voltage impressing terminal and grounding terminal	
20	VDD		
2	OSC	(Oscillating Terminal) One terminal type oscillating circuit is constituted by external C:R. Clock ($\approx 100\text{kHz}$) required for the system is produced.	I/O terminal
3	INH	(Inhibit Terminal) Normal operation at INH="H", and inhibit operation at INH="L". Volume/balance data with low consumption current is preserved. When INH="L" \rightarrow "H", the built-in supply voltage detecting circuit operates, and when $V_{DD} \leq V_{INT}$, volume/balance data is initialized.	C-MOS input terminal
4	K ₁	(Key Input Terminal) K ₁ and K ₂ constitute matrix with the digit output of T ₁ ~T ₄ , and can be connected with eight key switches at the maximum.	Input terminal with pull-down resistance
5	K ₂		
6	T ₄	(Digit Drive Output Terminal) It drives common terminal of indicating LED. Also used as scan signal of key matrix.	Bipolar output terminal
7	T ₃		
8	T ₂		
9	T ₁		
10	G	(Segment Drive Output Terminal) It drives segment terminal of indicating LED. Volume indication of 14 points can be made by matrix with T ₁ and T ₂ , while balance indication of 13 points is possible by matrix with T ₃ and T ₄ .	
11	F		
12	E		
13	D		
14	C		
15	B		
16	A		
17	STB	(Serial Control Output Terminal) This is serial data output terminal for transferring data to electronic volume IC.	C-MOS output terminal
18	DATA		
19	CK		

TC9185P, TC9195P

T-77-21

FUNCTION DESCRIPTION

TC9185P and TC9195P have the following function.

CONTROLLER	ELECTRONIC VOLUME	ATTENUATION AMOUNT	BALANCE	LOUDNESS	VOLUME INDICATION	BALANCE INDICATION
TC9185P	TC9176P	0~-76dB,-∞	±30dB	Without	14 points	13 points
	TC9177P			With		
TC9195P	TC9154P	0~-66dB,-∞		Without	13 points	

1. Volume Control Function

- . Step control of 2dB/1 push by UP, DOWN key.
- . Quick sending control with key continuous pressed.

2. Balance Control Function

- . Step control of 2dB/1 push by R,L key.
- . Quick sending control with key pressed. (Temporarily stopped during balance center time).

3. Indication Function

- . Volume indication is bar type indication of LED 14 points or 8 points(TC9185P).
Volume indication is bar type indication of LED 13 points or 7 points(TC9195P).
- . Balance indication is dot type indication of LED 13 points or 7 points.
- . Brightness of LED can be controlled by dimmer switch.

4. Loudness Control Function (TC9185P+TC9177P).

- . By loudness key, ON/OFF control and indication by LED is possible.

5. Inhibit Function

- . Inhibit circuit prohibits all inputs and outputs, and completely stops the operation of LSI, including oscillation of OSC. By this function, it is possible to back up volume/balance condition for a long time with capacitor or battery during power off time of the set.
- . Back up voltage is checked during the releasing of inhibit, and when it is below a certain voltage (V_{INT}), volume/balance data is judged to be indefinite and the initialization is made forcibly.

6. Initializing Function

- . Volume/balance value can be initialized by connecting initializing key or diode on the key matrix.
- . Initial value (volume-46dB/balance center).

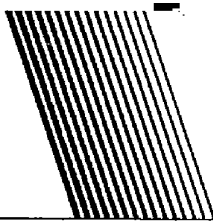

OPERATION EXPLANATION

1. Timing Producing Circuit

All timings required for the system can be produced by externally attaching C.R to OSC terminal (2 PIN).

Assuming the oscillation frequency as f_{OSC} , the timing will be decided as follows:

(In the case of $f_{OSC}=100kHz$)

- . Serial data transfer clock : $f_{CK}=f_{OSC}/4$ ($f_{CK}=25kHz$)
- . $T_1 \sim T_4$ digit signal output : $f_T=f_{OSC}/128$ ($f_T \approx 780Hz$)
- . Key input chattering preventing time: $t=7 \sim 8/f_T$ ($t \approx 9 \sim 10ms$)
- . Quick transfer time } : $T_A=320/f_T$ ($T_A \approx 0.4sec$)
- . Balance center stop time }
- . Quick scanning speed : $T_S=64/f_T$ ($T_S \approx 82ms$)

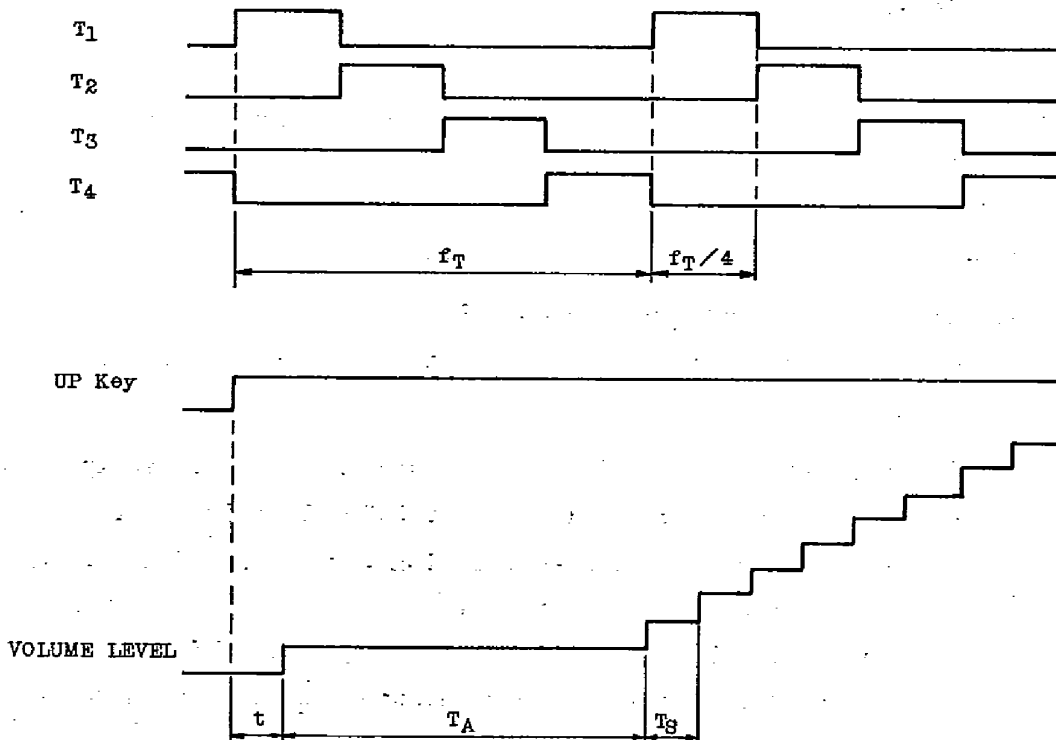

(Note) Oscillation frequency f_{OSC} sometimes fluctuates depending upon the fluctuation of IC and the change of supply voltage. (Refer to graph)

TC9185P, TC9195P

T-77-21

2. Digit Signal of T₁~T₄ and Input/Output Timing

In TC9185P and TC9195P, input/output signal operates in synchronism with the digit signal of T₁~T₄.

Segment output of A~G undergoes a change at each timing of T₁~T₄, and is sent out as dynamic data. In the case of K₁~K₂ key signal input, data reading is conducted in synchronism with T₁~T₄ inside LSI, and the meaning of instruction differs depending upon each timing.

SYMBOL	T ₁	T ₂	T ₃	T ₄
K ₁	VOLUME DOWN	BALANCE L	LOUDNESS ON/OFF	INITIALIZE
K ₂	" UP	" R	INDICATION DIMMER	—

A	0~-66dB	0~-18dB	R-30dB	L-4 ~ 2dB
B	0~-56dB	0~-14dB	R-28 ~ 22dB	L-8 ~ 6dB
C	0~-48dB	0~-10dB	R-20 ~ 16dB	L-14 ~ 10dB
D	0~-40dB	0 ~ -6dB	R-14 ~ 10dB	L-20 ~ 16dB
E	0~-32dB	0 ~ -4dB	R-8 ~ 6dB	L-28 ~ 22dB
F	0~-24dB	0 ~ -2dB	R-4 ~ 2dB	L-30dB
G	0~-76dB	0dB	CENTER (0dB)	LOUDNESS ON

Volume Indication

Balance Indication

- * Balance L key attenuates the volume on Rch side against on Lch side.
- * Balance R Key attenuates the volume on Lch side against on Rch side.
- * R-ndB of balance indication means that the volume attenuated ndB on Rch side against on Lch side.
- * Volume indication is made in semi-log unit.
- * When indication dimmer key is inputted the brightness of LED is half reduced.
- * When initializing key is inputted, the volume value is set at the initial point volume, -46dB, balance center, and loudness OFF.

(Note) The maximum attenuation rate of TC9195P is -66dB, so the indication of T₁-G (0~-76dB) becomes needless.

In the case of volume-up, DOWN and balance L,R, loudness key, double pressing is prohibited, and key input is not accepted then.

3. Volume Counter Circuit and Balance Detecting Circuit

TC9185P and TC9195P are provided with a couple of volume counters for the right and left channel use.

In the case of volume-up, the volume is increased by simultaneous up of the two volume counters.

In the case of volume-down, on the contrary, the volume is attenuated by simultaneous down of the two volume counters.

In the case of balance adjustment, after balance L key is inputted, the volume counter on R channel side is attenuated, and the sound field moves to L channel side. On the contrary when balance R key inputted, the volume counter on L channel side is attenuated, and the sound field moves to R channel side.

As the maximum value of balance is $-30\text{dB}/2\text{dB STEP}$, sound volume of single channel does not become "0" when the volume level exceeds -48dB (-38dB is the case of TC9195P), even at the maximum balance. The volume indication is always made with the value of greater volume level channel except the point of balance center.

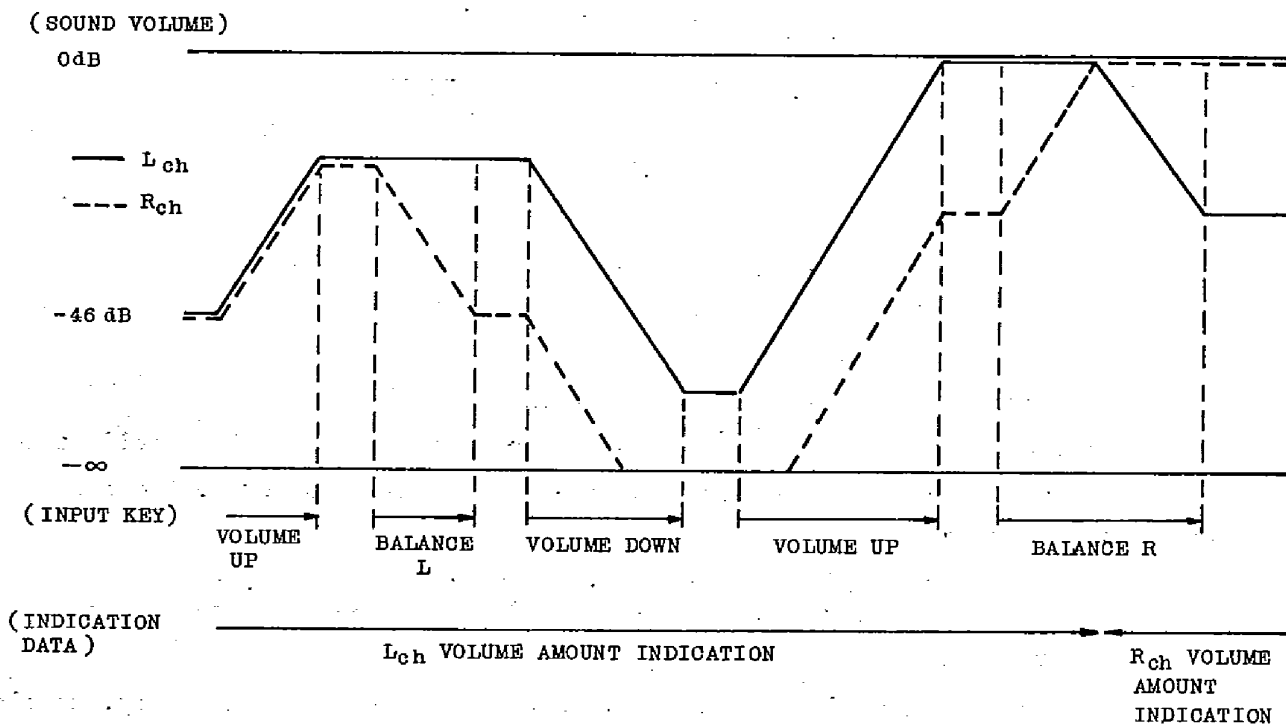

* When $L_{ch}=R_{ch}$ (balance center), Lch volume amount is indicated.

TC9185P, TC9195P

T-77-21

4. Serial Data Transfer Circuit

Serial data transfer circuit converts the value of a couple of volume counters to serial data, and when the value of volume counter has changed, the serial data is transferred to electronic volume IC in the sequence of L channel data and R channel two times.

. Serial Data Format

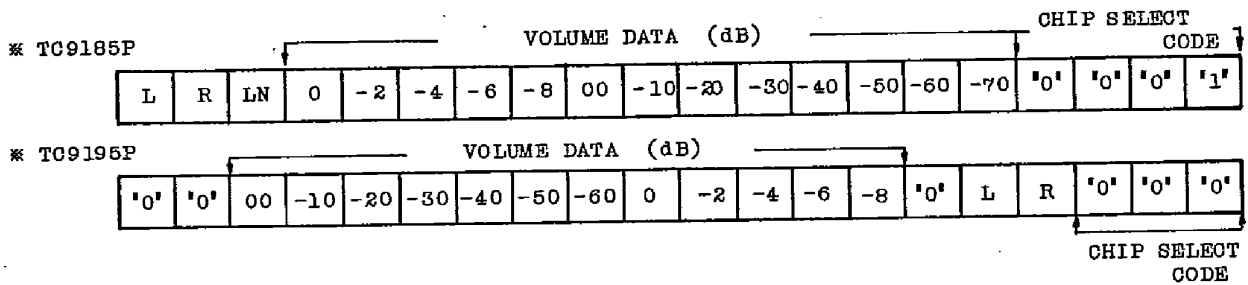
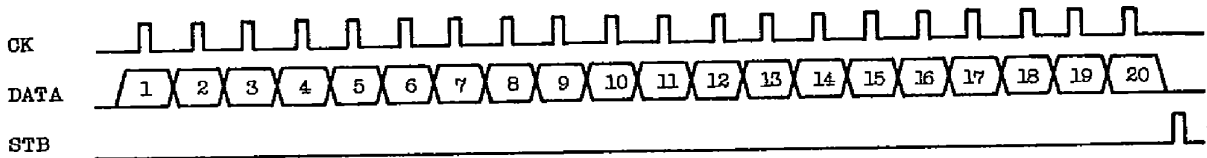

. Serial Data Timing

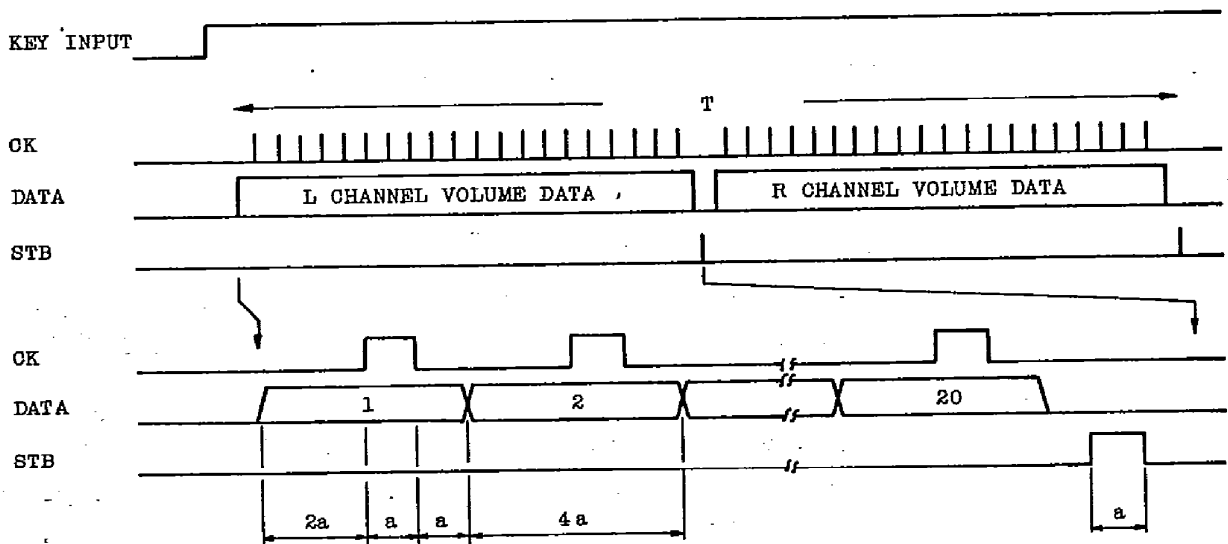

$a = 1/f_{OSC}$ (f_{OSC} : OSC terminal oscillating frequency.)

$T(\text{data transfer time}) = 168a$.

When $f_{OSC} = 100\text{kHz}$, $a = 10\mu\text{s}$

When $f_{OSC} = 100\text{kHz}$, $T = 1.68\text{ms}$

5. Key Input Circuit

Key input circuit is composed of matrix circuit by K₁, K₂ and T₁~T₄ digit signals.

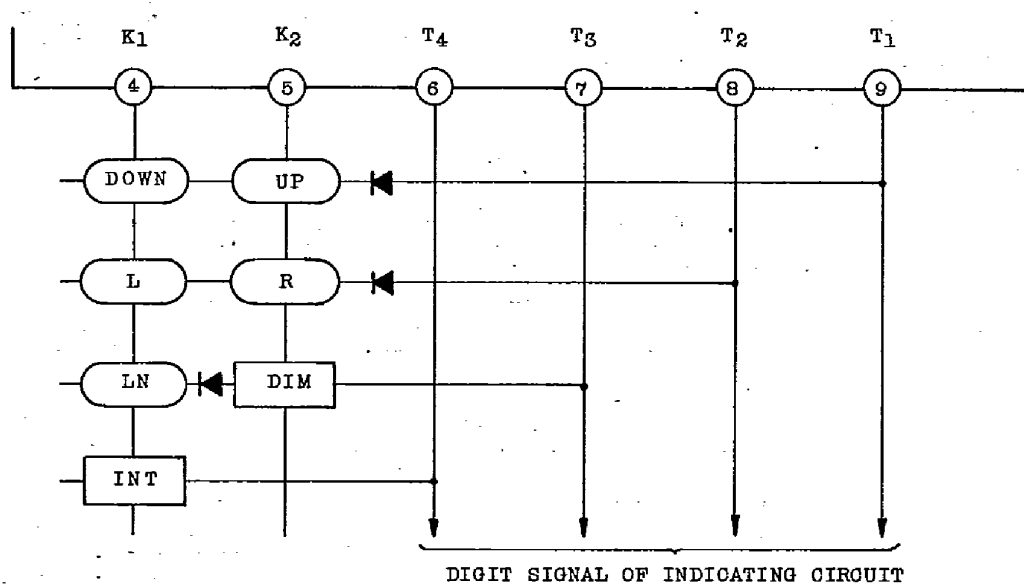

- . DOWN : Volume down key
- . UP : Volume up key
- . L : Left balance key
- . R : Right balance key
- . LN : Loudness ON/OFF key
- . DIM : Indicating dimmer switch
- . INT : Initialize switch

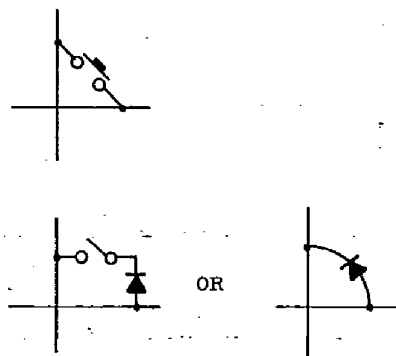

6. Inhibit Function

Inhibit function is to back up the volume balance condition during power off time. Inhibit condition is realized by setting the INH terminal at "L" level.

- . In the inhibit condition, oscillation of OSC circuit is stopped, no input can be accepted, and the indicating outputs (T₁~T₄, A~G) are all fixed at "L" level. By the above operation, consumption current during the inhibit condition is remarkably reduced. This makes possible the back-up with battery or capacitor.

TC9185P, TC9195P

T-77-21

. When releasing the inhibit (INH="H" level), at that time the supply voltage is checked, and if $V_{DD} > V_{INT}$, the memorized volume data is transferred to electronic volume IC, and the all operations are returned. If $V_{DD} \leq V_{INT}$, the back up data is judged to be undefined.

In this case, initialize circuit is operated, and after setting the initial point, the volume value with -46dB, balance center, loudness off, this data is transferred to electronic volume IC.

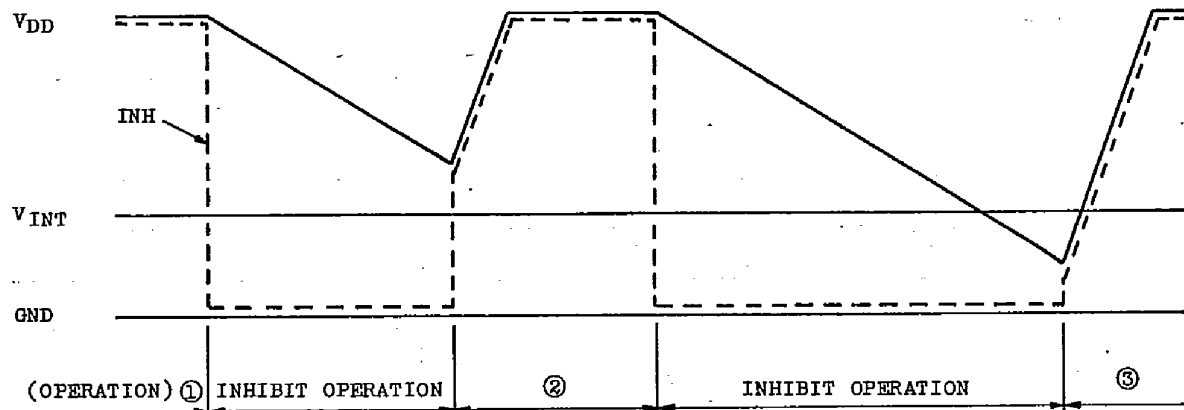

1. In the case of ②, the final volume balance data of ① is saved.
2. In the case of ③, the volume balance value is initialized.

Example of Back-up Circuit

Backup by battery or special power source.

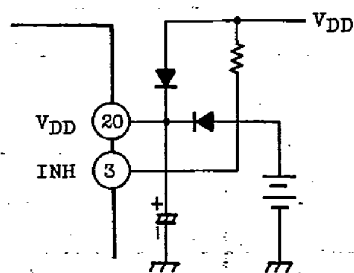

Backup by capacitor

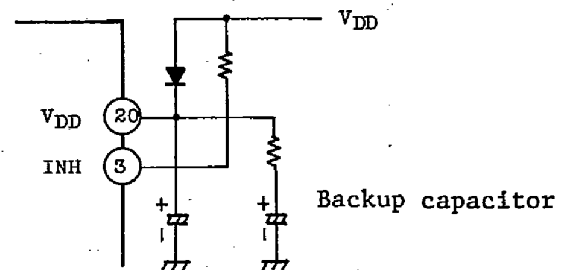

(Note) As data is transferred to the electronic volume IC during releasing time of inhibit, the power source of electronic volume IC must be rising at this point.

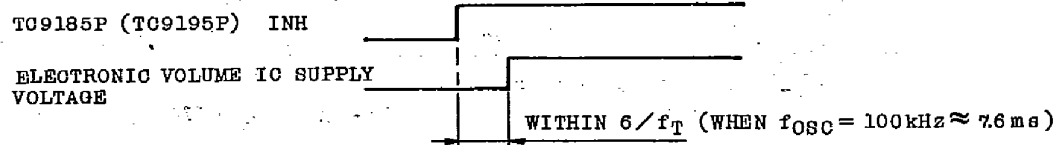

7. Volume Balance Indicating Circuit

In the case of TC9185P and TC9195P, indication of volume balance level by LED is possible.

Volume is bar type indication of LED 14 points (13 points in the case of T9195P), and balance is point type indication by LED 13 points. Owing to built-in bipolar transistor, LED can be directly driven.

. Connection of LED

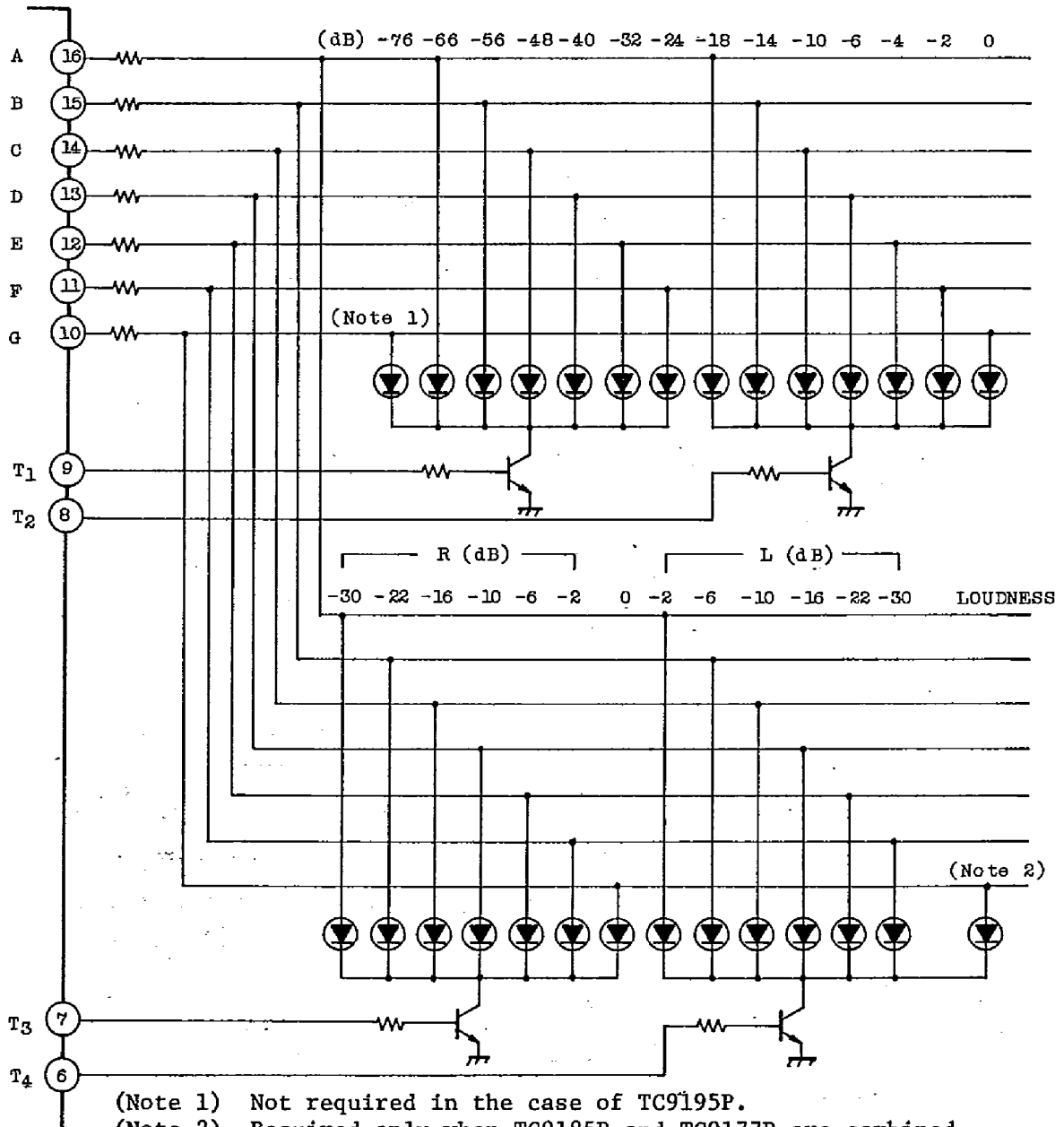

(Note 1) Not required in the case of TC9195P.

(Note 2) Required only when TC9185P and TC9177P are combined.

TC9185P, TC9195P

T-77-21

. Volume and Balance Amount and Indication

(VOLUME INDICATION)

dB	T ₁							T ₂						
	G	A	B	C	D	E	F	A	B	C	D	E	F	G
0	○	○	○	○	○	○	○	○	○	○	○	○	○	○
-2	○	○	○	○	○	○	○	○	○	○	○	○	○	
-4	○	○	○	○	○	○	○	○	○	○	○	○		
-6	○	○	○	○	○	○	○	○	○	○	○			
-8	○	○	○	○	○	○	○	○	○	○				
-10	○	○	○	○	○	○	○	○	○					
-12	○	○	○	○	○	○	○	○						
-14	○	○	○	○	○	○	○	○						
-16	○	○	○	○	○	○	○							
-18	○	○	○	○	○	○	○							
-20	○	○	○	○	○	○								
-22	○	○	○	○	○	○								
-24	○	○	○	○	○	○								
-26	○	○	○	○	○									
-28	○	○	○	○	○									
-30	○	○	○	○	○									
-32	○	○	○	○	○									
-34	○	○	○	○										
-36	○	○	○	○										
-38	○	○	○	○										
-40	○	○	○	○										
-42	○	○	○	○										
-44	○	○	○	○										
* -46	○	○	○	○										
-48	○	○	○	○										
-50	○	○	○											
-52	○	○	○											
-54	○	○	○											
-56	○	○	○											
-58	○	○												
-60	○	○												
-62	○	○												
-64	○	○												
-66	○	○												
-68	○													
-70	○													
-72	○													
-74	○													
-76	○													
-∞														

(BALANCE INDICATION)

dB	T ₃							T ₄							
	A	B	C	D	E	F	G	A	B	C	D	E	F		
-30	○														
-28		○													
-26			○												
-24				○											
-22					○										
-20						○									
-18							○								
-16								○							
-14									○						
-12										○					
-10											○				
-8												○			
-6													○		
-4														○	
-2															○
* CENTER															○
-2															○
-4															○
-6															○
-8															○
-10															○
-12															○
-14															○
-16															○
-18															○
-20															○
-22															○
-24															○
-26															○
-28															○
-30															○

○ : LED LIGHTS

* : INITIAL VALUE

TC9185P, TC9195P

T-77-21

. When Using Indication LED with 8 Points + 7 Points

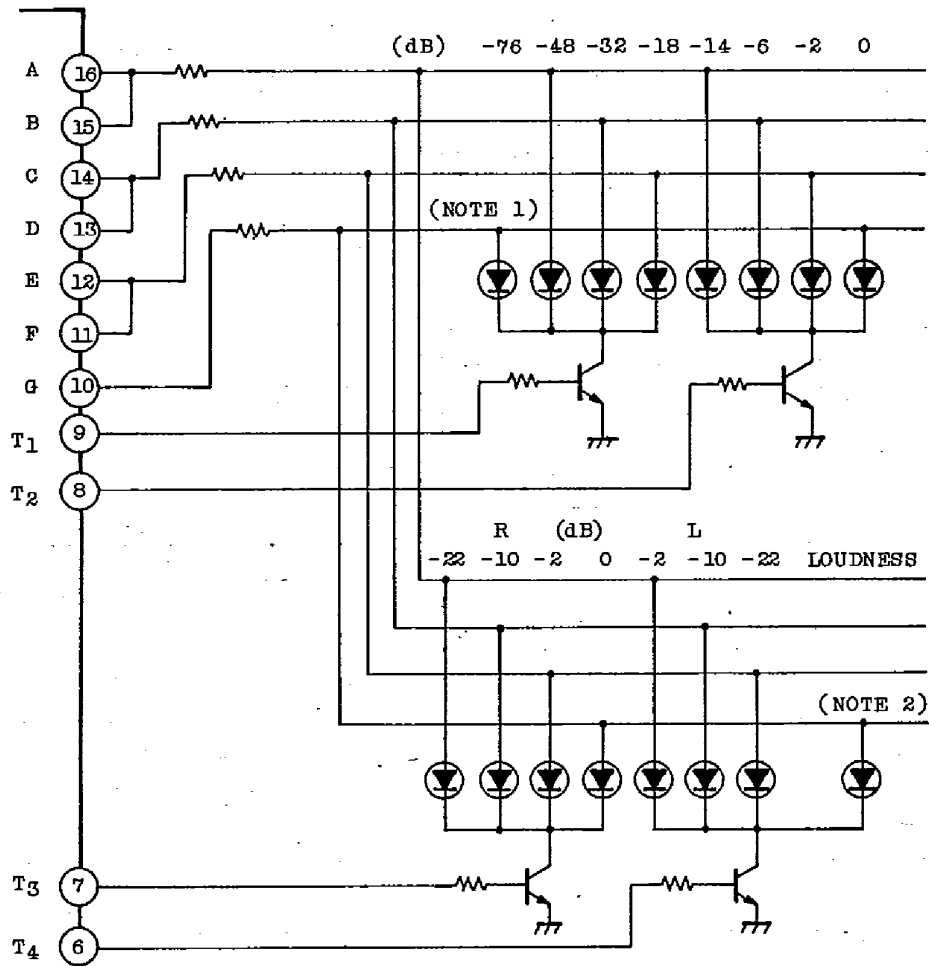

(Note 1) Not required in the case of TC9195P.

(Note 2) Required only when TC9185P and TC9177P are combined.

8. Others:

When back up operation is not required, K₁ through T₄ are connected with diode. At the power on time, the initialize circuit operates and initializes the volume balance value.

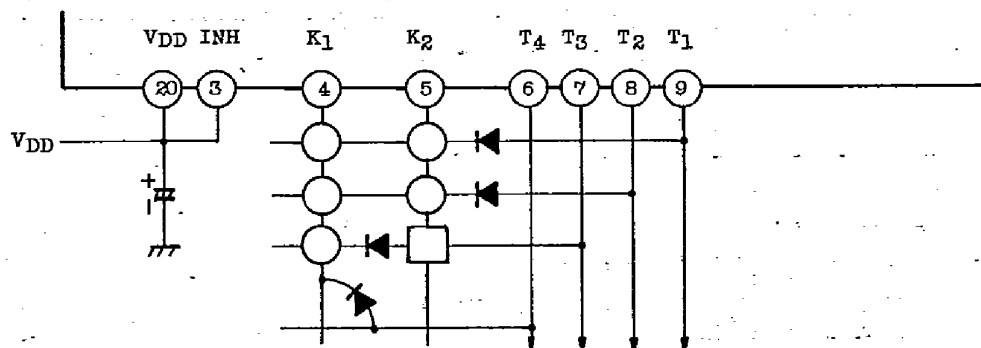

TC9185P, TC9195P

T-77-21

TC9185P, TC9195P APPLICATION CIRCUIT EXAMPLE

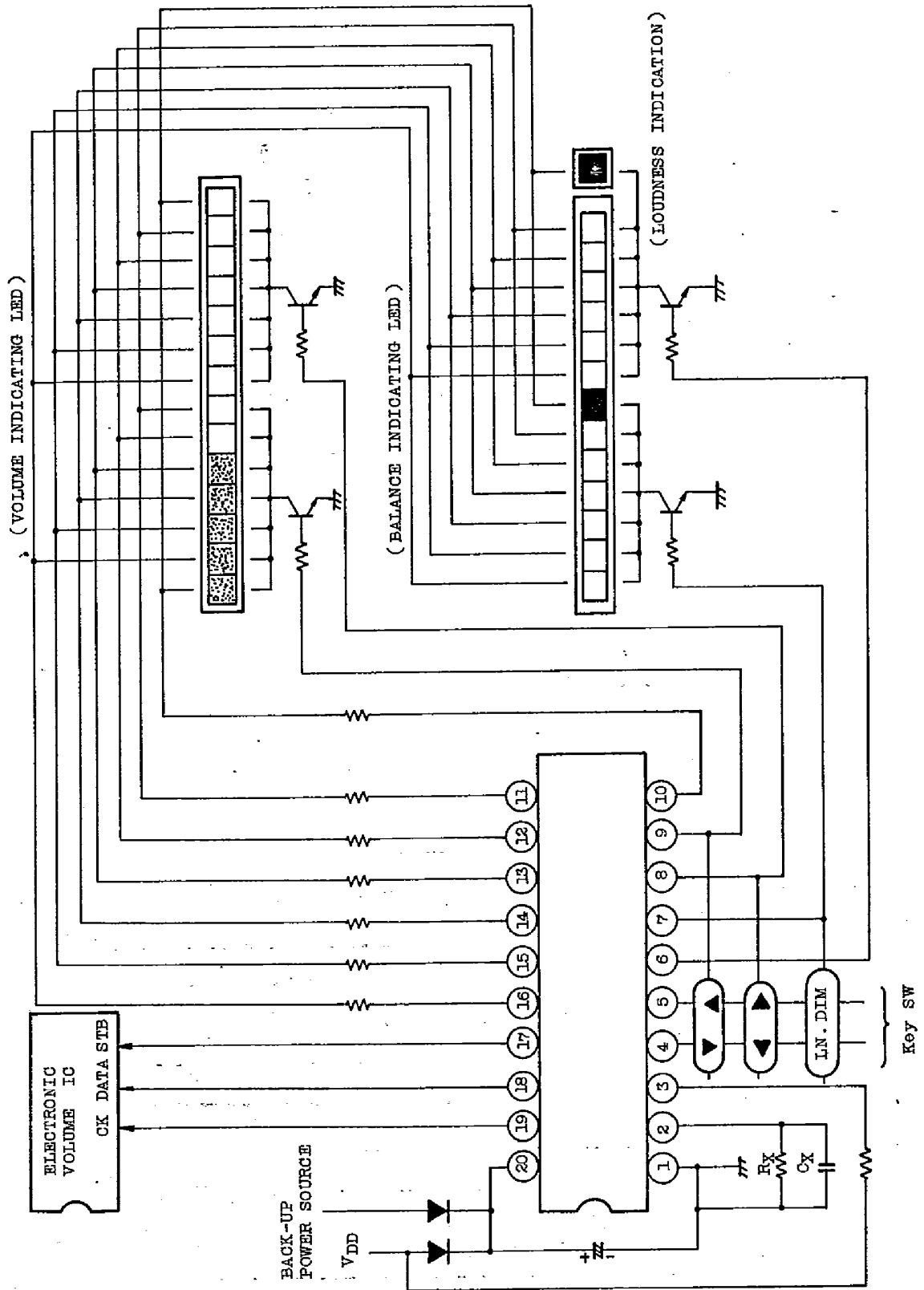

TC9185P, TC9195P

T-77-21

TC9154P APPLICATION CIRCUIT EXAMPLE

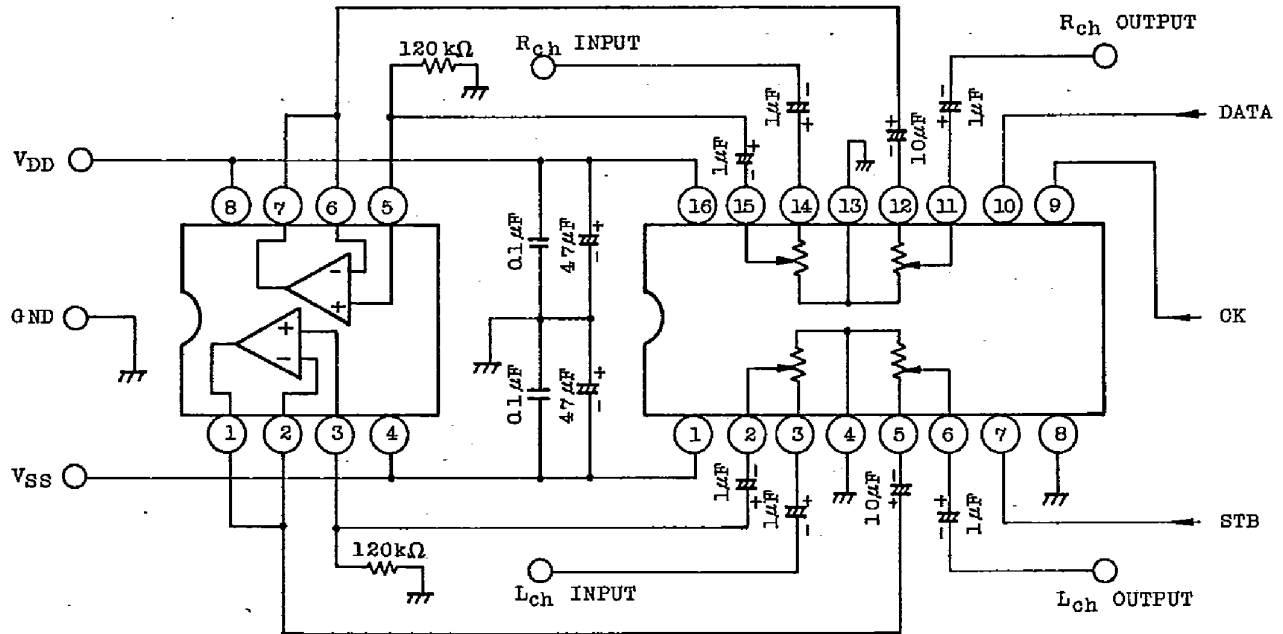

TC9176P APPLICATION CIRCUIT EXAMPLE

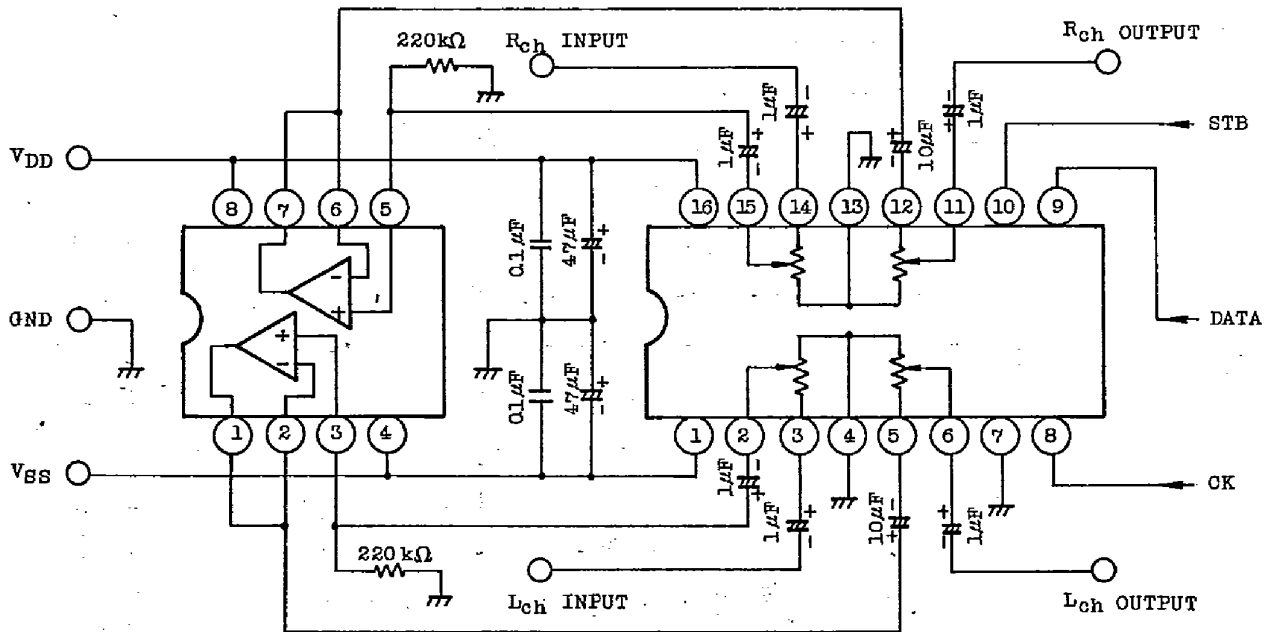

OP AMP : TA75558P, TA75559P or equivalent

TC9185P, TC9195P

T-77-21

TC9177P APPLICATION CIRCUIT EXAMPLE

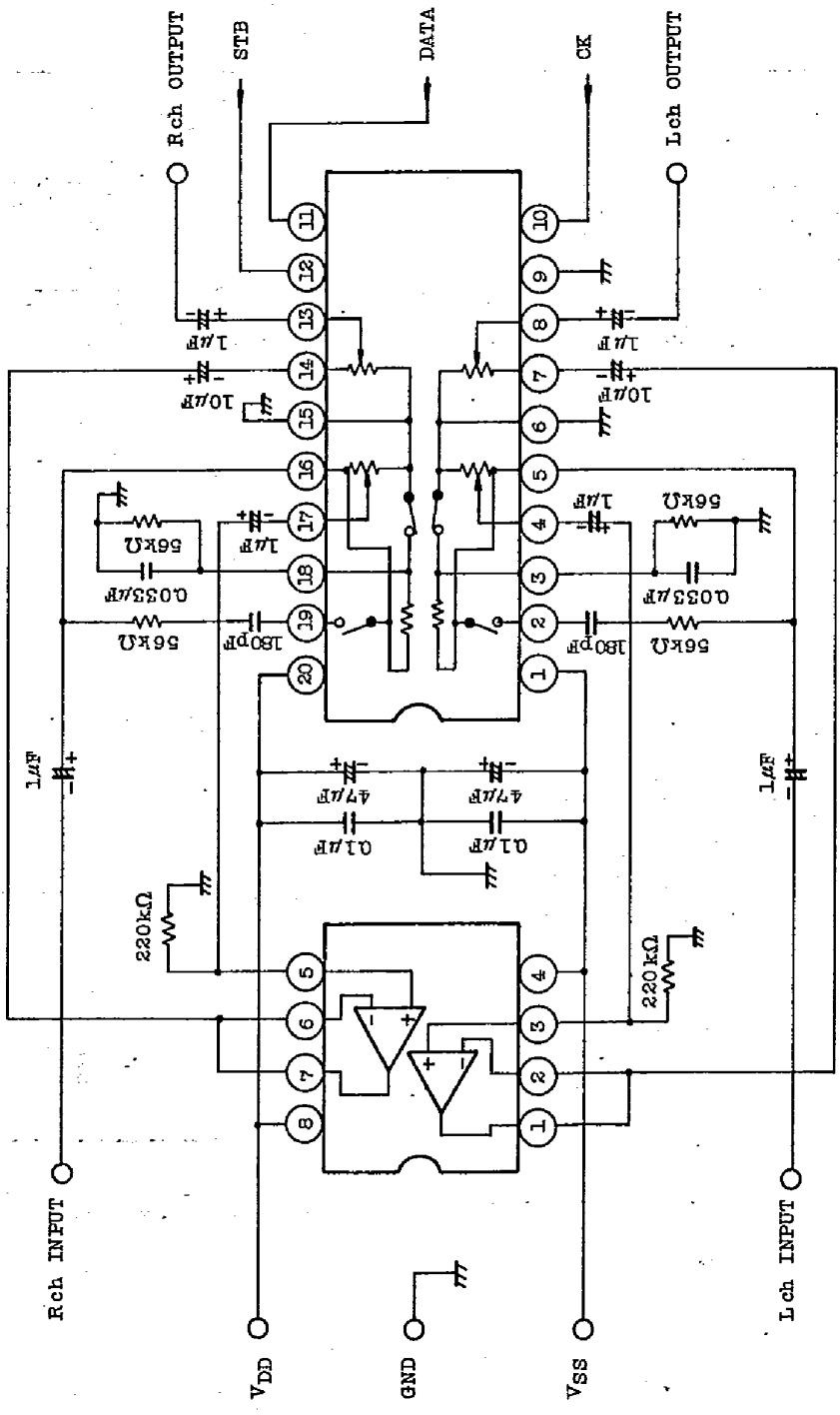

OPAMP : TA75558P, TA75559P or equivalent

TC9185P, TC9195P

T-77-21

GRAPH OSCILLATION FREQUENCY (f_{OSC}) CHARACTERISTICS

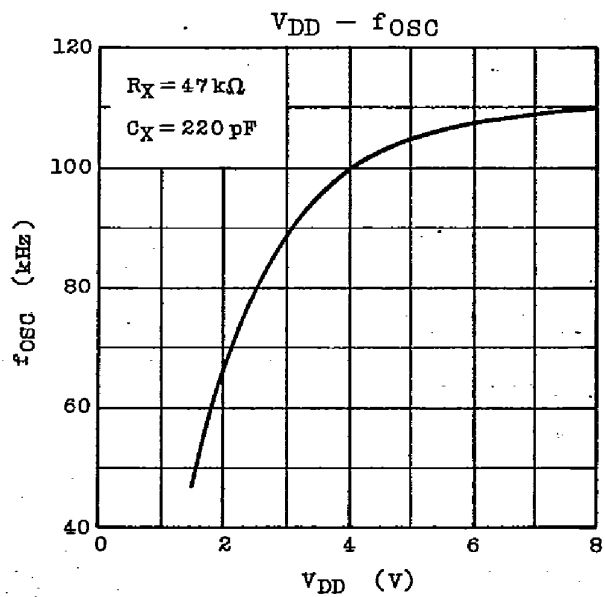
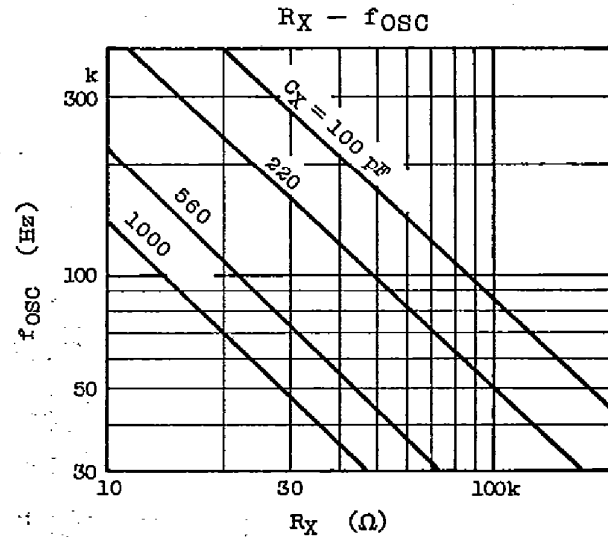
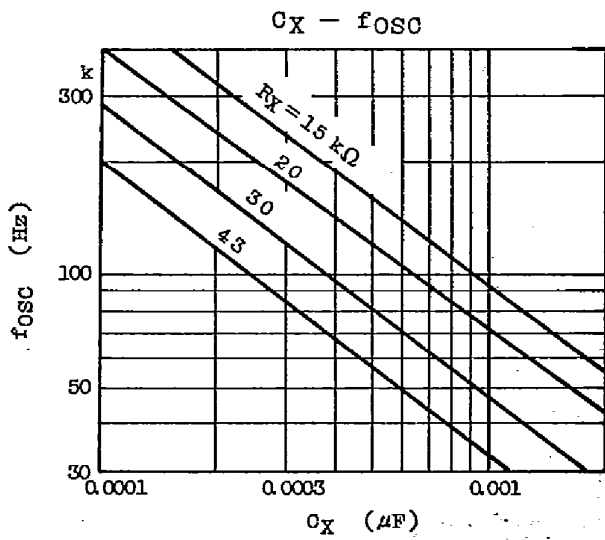

MEASURING CIRCUIT

