

# High Side Current Sense Amplifier with Reference and Comparators

## FEATURES

- Current Sense Amplifier
  - Fast Step Response: 500ns
  - Low Offset Voltage: 350 $\mu$ V Maximum
  - Low Input Bias Current: 300nA Maximum
- Internal 400mV Precision Reference
- Internal Latching Comparators with Reset
  - Fast Response Time: 700ns
  - Total Threshold Error:  $\pm 2\%$  Maximum
  - Two Comparator Polarity Options
- Wide Supply Range: 2.7V to 60V
- Supply Current: 550 $\mu$ A
- Low Shutdown Current: 5 $\mu$ A
- Specified for  $-40^{\circ}\text{C}$  to  $125^{\circ}\text{C}$  Temperature Range
- Available in 10-Lead MSOP Package

## APPLICATIONS

- Overcurrent, Undercurrent and Fault Detection
- Current Shunt Measurement
- Battery Monitoring
- Motor Control
- Automotive Monitoring and Control
- Remote Sensing
- Industrial Control

## DESCRIPTION

The LT<sup>®</sup>6109 is a complete high side current sense device that incorporates a precision current sense amplifier, an integrated voltage reference and two comparators. Two versions of the LT6109 are available. The LT6109-1 has the comparators connected in opposing polarity and the LT6109-2 has the comparators connected in the same polarity. In addition, the current sense amplifier and comparator outputs are directly accessible. The amplifier gain and comparator trip points are configured by external resistors. The open-drain comparator outputs allows for easy interface to other system components.

The combined system propagation delay of the LT6109 is typically only 1.4 $\mu$ s, allowing for quick reaction to overcurrent and undercurrent conditions. The 1MHz bandwidth allows the LT6109 to be used for error detection in critical applications such as motor control. The high threshold accuracy of the comparators, combined with the ability to latch both comparators, ensures the LT6109 can capture high speed events.

The LT6109 is fully specified for operation from  $-40^{\circ}\text{C}$  to  $125^{\circ}\text{C}$ , making it suitable for industrial and automotive applications. The LT6109 is available in a small 10-lead MSOP.

LT, LT, LTC, LTM, TimerBlox, Linear Technology and the Linear logo are registered trademarks of Linear Technology Corporation. All other trademarks are the property of their respective owners.

## TYPICAL APPLICATION

Circuit Fault Protection with Latching Load Disconnect and Early Warning Indication

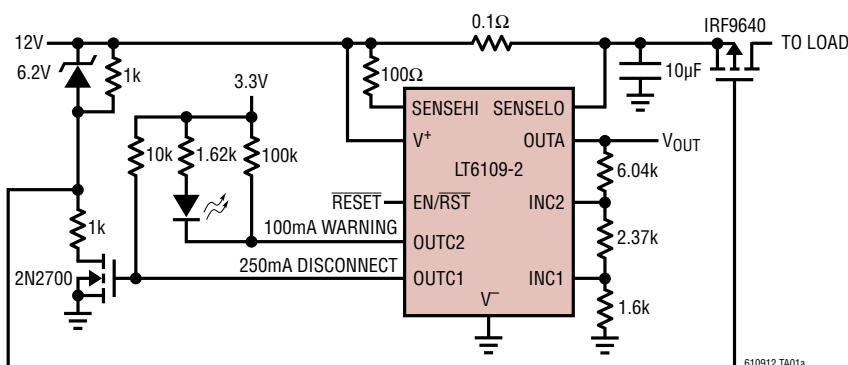

Response to Overcurrent Event

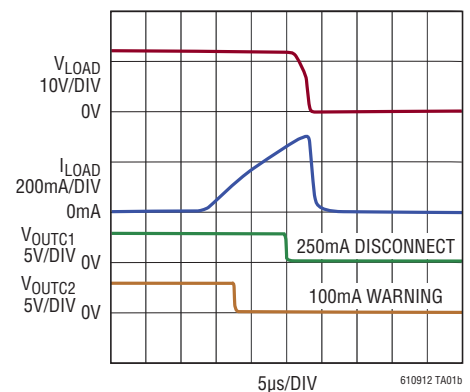

# LT6109-1/LT6109-2

## ABSOLUTE MAXIMUM RATINGS

(Note 1)

|   |                |
|---|----------------|
| Total Supply Voltage ( $V^+$ to $V^-$ )     | 60V            |
| Maximum Voltage<br>(SENSELO, SENSEHI, OUTA) | $V^+ + 1V$     |
| Maximum $V^+ -$ (SENSELO or SENSEHI)        | 33V            |
| Maximum $EN/\overline{RST}$ Voltage         | 60V            |
| Maximum Comparator Input Voltage            | 60V            |
| Maximum Comparator Output Voltage           | 60V            |
| Amplifier Input Current (Note 2)            | -10mA          |
| SENSEHI or SENSELO Input Current            | $\pm 10mA$     |
| Differential SENSEHI, SENSELO Input Current | $\pm 2.5mA$    |
| Amplifier Output Short-Circuit Duration     | Indefinite     |
| Operating Temperature Range (Note 3)        |                |
| LT6109I                                     | -40°C to 85°C  |
| LT6109H                                     | -40°C to 125°C |
| Specified Temperature Range (Note 3)        |                |
| LT6109I                                     | -40°C to 85°C  |
| LT6109H                                     | -40°C to 125°C |
| Maximum Junction Temperature                | 150°C          |
| Storage Temperature Range                   | -65°C to 150°C |
| Lead Temperature (Soldering, 10 sec)        | 300°C          |

## PIN CONFIGURATION

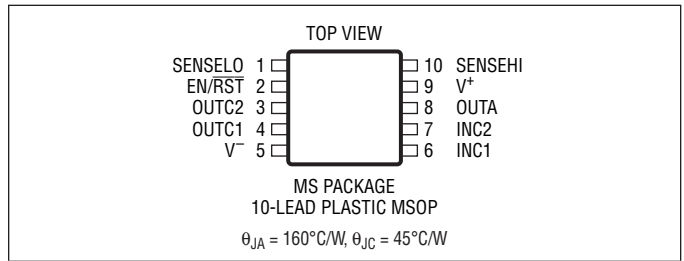

## ORDER INFORMATION

| LEAD FREE FINISH | TAPE AND REEL     | PART MARKING* | PACKAGE DESCRIPTION  | SPECIFIED TEMPERATURE RANGE |
|------------------|-------------------|---------------|----------------------|-----------------------------|
| LT6109IMS-1#PBF  | LT6109IMS-1#TRPBF | LTFNJ         | 10-Lead Plastic MSOP | -40°C to 85°C               |
| LT6109HMS-1#PBF  | LT6109HMS-1#TRPBF | LTFNJ         | 10-Lead Plastic MSOP | -40°C to 125°C              |
| LT6109IMS-2#PBF  | LT6109IMS-2#TRPBF | LTFWY         | 10-Lead Plastic MSOP | -40°C to 85°C               |
| LT6109HMS-2#PBF  | LT6109HMS-2#TRPBF | LTFWY         | 10-Lead Plastic MSOP | -40°C to 125°C              |

Consult LTC Marketing for parts specified with wider operating temperature ranges. \*The temperature grade is identified by a label on the shipping container. Consult LTC Marketing for information on non-standard lead based finish parts.

For more information on lead free part marking, go to: <http://www.linear.com/leadfree/>

For more information on tape and reel specifications, go to: <http://www.linear.com/tapeandreel/>

**ELECTRICAL CHARACTERISTICS** The ● denotes the specifications which apply over the full operating temperature range, otherwise specifications are at  $T_A = 25^\circ\text{C}$ .  $V^+ = 12\text{V}$ ,  $V_{\text{PULLUP}} = V^+$ ,  $V_{\text{EN/RST}} = 2.7\text{V}$ ,  $R_{\text{IN}} = 100\Omega$ ,  $R_{\text{OUT}} = R1 + R2 + R3 = 10\text{k}$ , gain = 100,  $R_C = 25.5\text{k}$ ,  $C_L = C_{\text{LC}} = 2\text{pF}$ , unless otherwise noted. (See Figure 3)

| SYMBOL | PARAMETER                  | CONDITIONS   | MIN   | TYP  | MAX         | UNITS                          |
|--------|----------------------------|--|-------|------|-------------|--------------------------------|
| $V^+$  | Supply Voltage Range       |  | ● 2.7 |      | 60          | V                              |
| $I_S$  | Supply Current (Note 4)    | $V^+ = 2.7\text{V}$ , $R_{\text{IN}} = 1\text{k}$ , $V_{\text{SENSE}} = 5\text{mV}$                                    |       | 475  |             | $\mu\text{A}$                  |
|        |                            | $V^+ = 60\text{V}$ , $R_{\text{IN}} = 1\text{k}$ , $V_{\text{SENSE}} = 5\text{mV}$                                     | ●     | 600  | 700<br>1000 | $\mu\text{A}$<br>$\mu\text{A}$ |
|        | Supply Current in Shutdown | $V^+ = 2.7\text{V}$ , $V_{\text{EN/RST}} = 0\text{V}$ , $R_{\text{IN}} = 1\text{k}$ , $V_{\text{SENSE}} = 0.5\text{V}$ | ●     | 3    | 5<br>7      | $\mu\text{A}$<br>$\mu\text{A}$ |
|        |                            | $V^+ = 60\text{V}$ , $V_{\text{EN/RST}} = 0\text{V}$ , $R_{\text{IN}} = 1\text{k}$ , $V_{\text{SENSE}} = 0.5\text{V}$  | ●     | 7    | 11<br>13    | $\mu\text{A}$<br>$\mu\text{A}$ |
|        | EN/RST Pin Current         | $V_{\text{EN/RST}} = 0\text{V}$ , $V^+ = 60\text{V}$   |       | -200 |             | nA                             |
|        | EN/RST Pin Threshold       | $V^+ = 2.7\text{V}$ to $60\text{V}$  | ●     | 0.8  | 1.9         | V                              |

**Current Sense Amplifier**

|                                 |  |   |   |              |            |                                |
|---------------------------------|--|---|---|--------------|------------|--------------------------------|
| $V_{\text{OS}}$                 | Input Offset Voltage                                 | $V_{\text{SENSE}} = 5\text{mV}$   | ● | -350<br>-450 | 350<br>450 | $\mu\text{V}$<br>$\mu\text{V}$ |
| $\Delta V_{\text{OS}}/\Delta T$ | Input Offset Voltage Drift                           | $V_{\text{SENSE}} = 5\text{mV}$   | ● | $\pm 0.8$    |            | $\mu\text{V}/^\circ\text{C}$   |
| $I_B$                           | Input Bias Current (SENSELO, SENSEHI) (Note 5)       | $V^+ = 2.7\text{V}$ to $60\text{V}$   | ● | 60           | 300<br>350 | nA<br>nA                       |
| $I_{\text{OS}}$                 | Input Offset Current                                 | $V^+ = 2.7\text{V}$ to $60\text{V}$   |   | $\pm 5$      |            | nA                             |
| $I_{\text{OUTA}}$               | Maximum Output Current (Note 6)                      |   | ● | 1            |            | mA                             |
| PSRR                            | Power Supply Rejection Ratio (Note 7)                | $V^+ = 2.7\text{V}$ to $60\text{V}$ , $V_{\text{SENSE}} = 5\text{mV}$                                 | ● | 120          | 127        | dB                             |
|                                 |  |   | ● | 114          |            | dB                             |
| CMRR                            | Common Mode Rejection Ratio                          | $V^+ = 36\text{V}$ , $V_{\text{SENSE}} = 5\text{mV}$ , $V_{\text{ICM}} = 2.7\text{V}$ to $36\text{V}$ |   | 125          |            | dB                             |
|                                 |  | $V^+ = 60\text{V}$ , $V_{\text{SENSE}} = 5\text{mV}$ , $V_{\text{ICM}} = 27\text{V}$ to $60\text{V}$  | ● | 110<br>103   | 125        | dB<br>dB                       |
| $V_{\text{SENSE(MAX)}}$         | Full-Scale Input Sense Voltage (Note 6)              | $R_{\text{IN}} = 500\Omega$   | ● | 500          |            | mV                             |
|                                 | Gain Error (Note 8)                                  | $V^+ = 2.7\text{V}$ , $V_{\text{SENSE}} = 5\text{mV}$ to $24\text{mV}$                                | ● | -0.2         | -0.08      | %                              |
|                                 |  | $V^+ = 12\text{V}$ to $60\text{V}$ , $V_{\text{SENSE}} = 5\text{mV}$ to $100\text{mV}$                | ● |              | 0          | %                              |
|                                 | SENSELO Voltage (Note 9)                             | $V^+ = 2.7\text{V}$ , $V_{\text{SENSE}} = 100\text{mV}$ , $R_{\text{OUT}} = 2\text{k}$                | ● | 2.5          |            | V                              |
|                                 |  | $V^+ = 60\text{V}$ , $V_{\text{SENSE}} = 100\text{mV}$  | ● | 27           |            | V                              |
|                                 | Output Swing High ( $V^+$ to $V_{\text{OUTA}}$ )     | $V^+ = 2.7\text{V}$ , $V_{\text{SENSE}} = 27\text{mV}$  | ● |              | 0.2        | V                              |
|                                 |  | $V^+ = 12\text{V}$ , $V_{\text{SENSE}} = 120\text{mV}$  | ● |              | 0.5        | V                              |
| BW                              | Signal Bandwidth                                     | $I_{\text{OUT}} = 1\text{mA}$   |   | 1            |            | MHz                            |
|                                 |  | $I_{\text{OUT}} = 100\mu\text{A}$   |   | 140          |            | kHz                            |
| $t_r$                           | Input Step Response (to 50% of Final Output Voltage) | $V^+ = 2.7\text{V}$ , $V_{\text{SENSE}} = 24\text{mV}$ Step, Output Rising Edge                       |   | 500          |            | ns                             |
|                                 |  | $V^+ = 12\text{V}$ to $60\text{V}$ , $V_{\text{SENSE}} = 100\text{mV}$ Step, Output Rising Edge       |   | 500          |            | ns                             |
| $t_{\text{SETTLE}}$             | Settling Time to 1%                                  | $V_{\text{SENSE}} = 10\text{mV}$ to $100\text{mV}$ , $R_{\text{OUT}} = 2\text{k}$                     |   | 2            |            | $\mu\text{s}$                  |

# LT6109-1/LT6109-2

**ELECTRICAL CHARACTERISTICS** The ● denotes the specifications which apply over the full operating temperature range, otherwise specifications are at  $T_A = 25^\circ\text{C}$ .  $V^+ = 12\text{V}$ ,  $V_{\text{PULLUP}} = V^+$ ,  $V_{\text{EN/RST}} = 2.7\text{V}$ ,  $R_{\text{IN}} = 100\Omega$ ,  $R_{\text{OUT}} = R_1 + R_2 + R_3 = 10\text{k}$ , gain = 100,  $R_C = 25.5\text{k}$ ,  $C_L = C_{\text{LC}} = 2\text{pF}$ , unless otherwise noted. (See Figure 3)

| SYMBOL                          | PARAMETER  | CONDITIONS   | MIN   | TYP      | MAX        | UNITS                          |    |
|---------------------------------|--|--|-------|----------|------------|--------------------------------|----|
| <b>Reference and Comparator</b> |  |  |       |          |            |                                |    |
| $V_{\text{TH(R)}}$<br>(Note 10) | Rising Input Threshold Voltage<br>(LT6109-1 Comparator 1<br>LT6109-2 Both Comparators) | $V^+ = 2.7\text{V}$ to 60V                                   | ● 392 | 400      | 408        | mV                             |    |
| $V_{\text{TH(F)}}$<br>(Note 10) | Falling Input Threshold Voltage<br>(LT6109-1 Comparator 2)                             | $V^+ = 2.7\text{V}$ to 60V                                   | ● 392 | 400      | 408        | mV                             |    |
| $V_{\text{HYS}}$                | $V_{\text{HYS}} = V_{\text{TH(R)}} - V_{\text{TH(F)}}$ (Note 5)                        | $V^+ = 2.7\text{V}$ to 60V                                   |       | 3        | 10         | 15                             | mV |
|                                 | Comparator Input Bias Current  | $V_{\text{INC1,2}} = 0\text{V}$ , $V^+ = 60\text{V}$         | ● -50 |          |            | nA                             |    |
| $V_{\text{OL}}$                 | Output Low Voltage   | $I_{\text{OUTC1,C2}} = 500\mu\text{A}$ , $V^+ = 2.7\text{V}$ | ●     | 60       | 150<br>220 | mV<br>mV                       |    |
|                                 | High to Low Propagation Delay  | 5mV Overdrive<br>100mV Overdrive                             |       | 3<br>0.5 |            | $\mu\text{s}$<br>$\mu\text{s}$ |    |
|                                 | Output Fall Time   |  |       | 0.08     |            | $\mu\text{s}$                  |    |
| $t_{\text{RESET}}$              | Reset Time   |  |       | 0.5      |            | $\mu\text{s}$                  |    |
| $t_{\text{RPW}}$                | Valid $\overline{\text{RST}}$ Pulse Width  |  | ● 2   |          | 15         | $\mu\text{s}$                  |    |

**Note 1:** Stresses beyond those listed under Absolute Maximum Ratings may cause permanent damage to the device. Exposure to any Absolute Maximum Rating condition for extended periods may affect device reliability and lifetime.

**Note 2:** Input and output pins have ESD diodes connected to ground.

**Note 3:** The LT6109I is guaranteed to meet specified performance from  $-40^\circ\text{C}$  to  $85^\circ\text{C}$ . LT6109H is guaranteed to meet specified performance from  $-40^\circ\text{C}$  to  $125^\circ\text{C}$ .

**Note 4:** Supply current is specified with the comparator outputs high. When the comparator outputs go low the supply current will increase by  $75\mu\text{A}$  typically per comparator.

**Note 5:** This specification is limited by the accuracy of automated testing.

**Note 6:** The full-scale input sense voltage and the maximum output current must be considered to achieve the specified performance.

**Note 7:** Supply voltage and input common mode voltage are varied while amplifier input offset voltage is monitored.

**Note 8:** Specified gain error does not include the effects of external resistors  $R_{\text{IN}}$  and  $R_{\text{OUT}}$ .

**Note 9:** Refer to SENSELO, SENSEHI Range in the Applications Information section for more information.

**Note 10:** The input threshold voltage which causes the output voltage of the comparator to transition from high to low is specified. The input voltage which causes the comparator output to transition from low to high is the magnitude of the difference between the specified threshold and the hysteresis.

**TYPICAL PERFORMANCE CHARACTERISTICS** Performance characteristics taken at  $T_A = 25^\circ\text{C}$ ,  $V^+ = 12\text{V}$ ,  $V_{\text{PULLUP}} = V^+$ ,  $V_{\text{EN/RST}} = 2.7\text{V}$ ,  $R_{\text{IN}} = 100\Omega$ ,  $R_{\text{OUT}} = R1 + R2 + R3 = 10\text{k}$ , gain = 100,  $R_C = 25.5\text{k}$ ,  $C_L = C_{\text{LC}} = 2\text{pF}$ , unless otherwise noted. (See Figure 3)

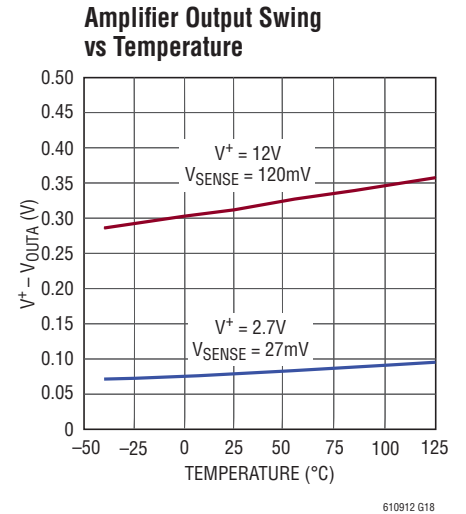
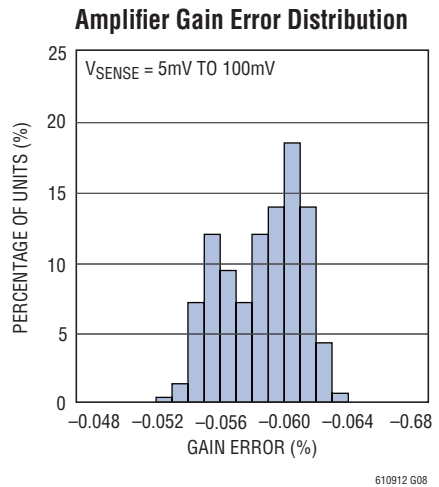
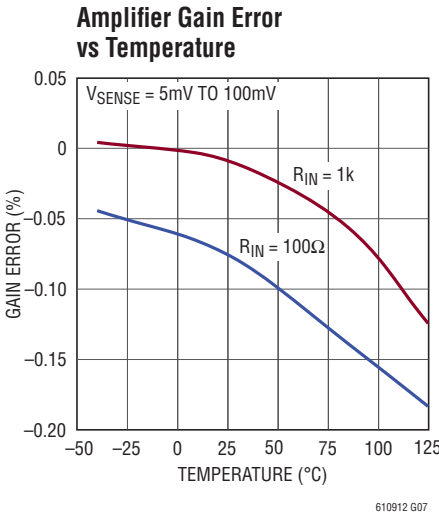
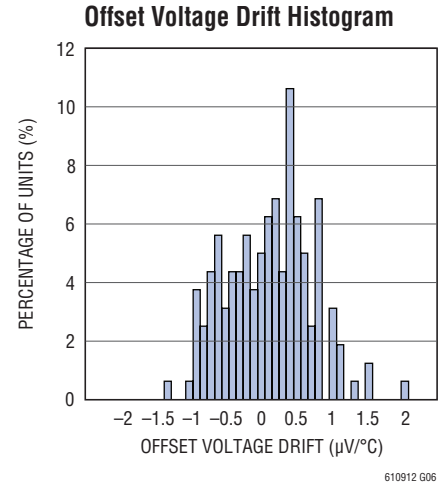
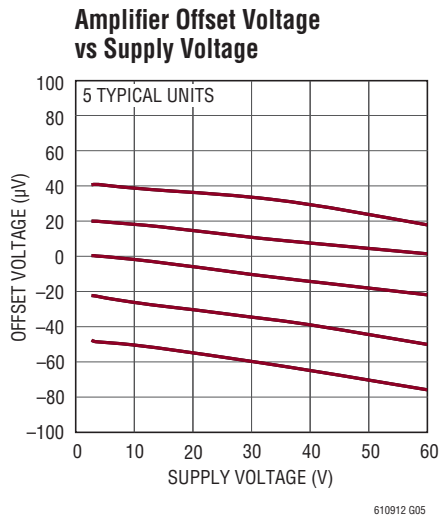
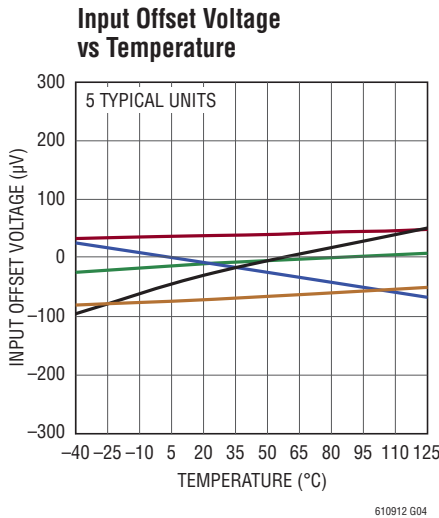
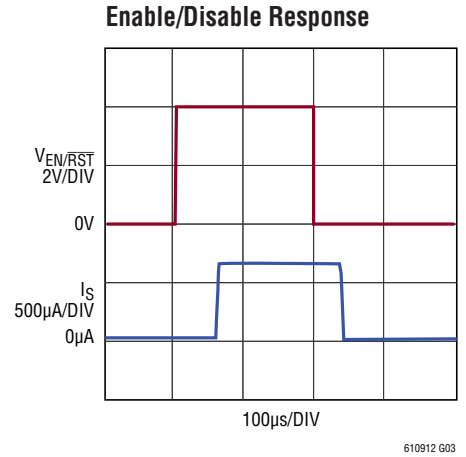
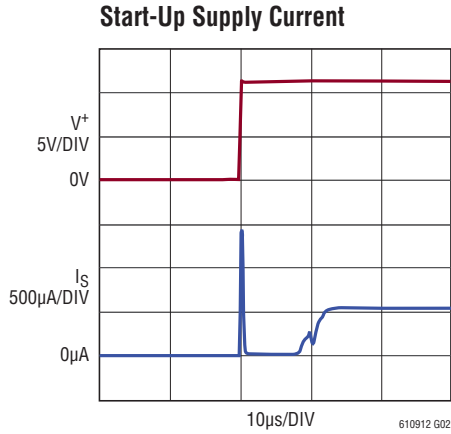
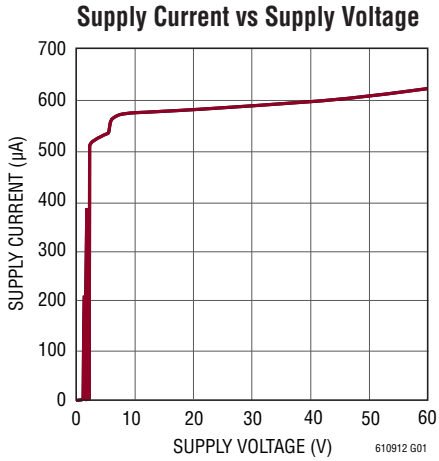

# LT6109-1/LT6109-2

**TYPICAL PERFORMANCE CHARACTERISTICS** Performance characteristics taken at  $T_A = 25^\circ\text{C}$ ,  $V^+ = 12\text{V}$ ,  $V_{\text{PULLUP}} = V^+$ ,  $V_{\text{EN/RST}} = 2.7\text{V}$ ,  $R_{\text{IN}} = 100\Omega$ ,  $R_{\text{OUT}} = R_1 + R_2 + R_3 = 10\text{k}$ , gain = 100,  $R_C = 25.5\text{k}$ ,  $C_L = C_{\text{LC}} = 2\text{pF}$ , unless otherwise noted. (See Figure 3)

**Power Supply Rejection Ratio vs Frequency**

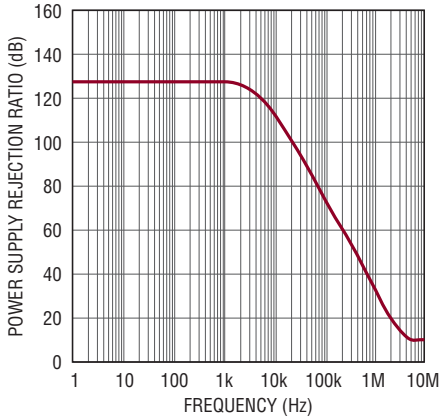

610912 G09

**Common Mode Rejection Ratio vs Frequency**

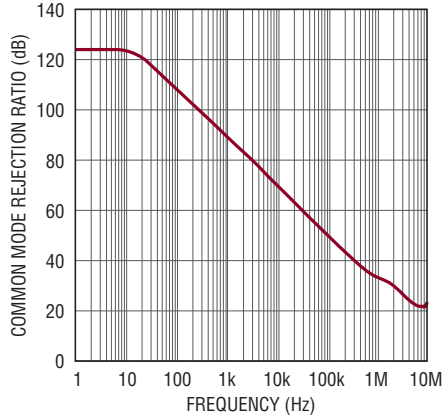

610912 G10

**Amplifier Gain vs Frequency**

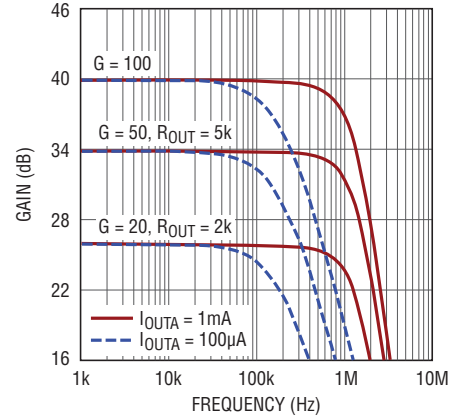

610912 G11

**System Step Response**

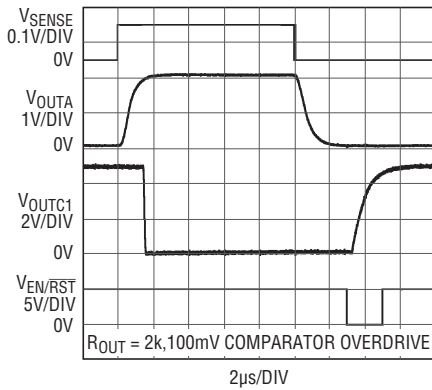

610912 G12

**Amplifier Input Bias Current vs Temperature**

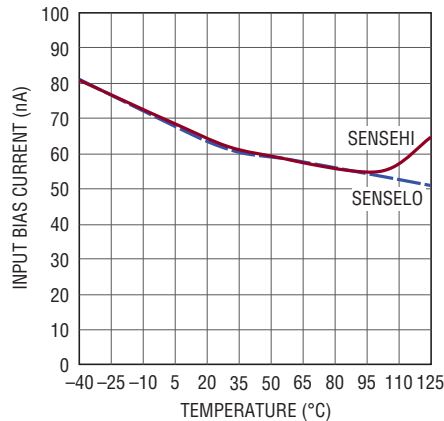

610912 G13

**Amplifier Step Response ( $V_{\text{SENSE}} = 0\text{mV}$  to  $100\text{mV}$ )**

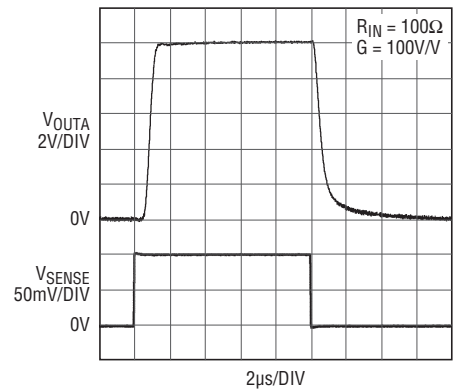

610912 G14

**Amplifier Step Response ( $V_{\text{SENSE}} = 10\text{mV}$  to  $100\text{mV}$ )**

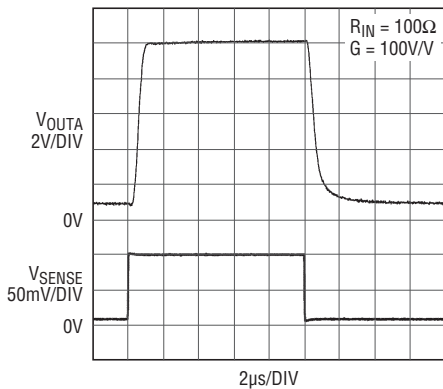

610912 G15

**Amplifier Step Response ( $V_{\text{SENSE}} = 0\text{mV}$  to  $100\text{mV}$ )**

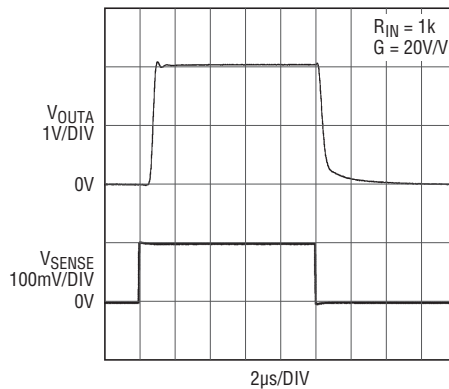

610912 G16

**Amplifier Step Response ( $V_{\text{SENSE}} = 10\text{mV}$  to  $100\text{mV}$ )**

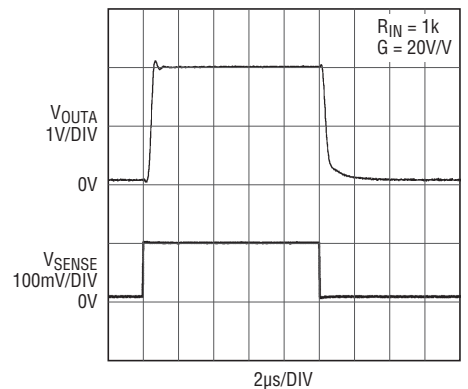

610912 G17

610912f

**TYPICAL PERFORMANCE CHARACTERISTICS** Performance characteristics taken at  $T_A = 25^\circ\text{C}$ ,  $V^+ = 12\text{V}$ ,  $V_{\text{PULLUP}} = V^+$ ,  $V_{\text{EN/RST}} = 2.7\text{V}$ ,  $R_{\text{IN}} = 100\Omega$ ,  $R_{\text{OUT}} = R1 + R2 + R3 = 10\text{k}$ , gain = 100,  $R_C = 25.5\text{k}$ ,  $C_L = C_{\text{LC}} = 2\text{pF}$ , unless otherwise noted. (See Figure 3)

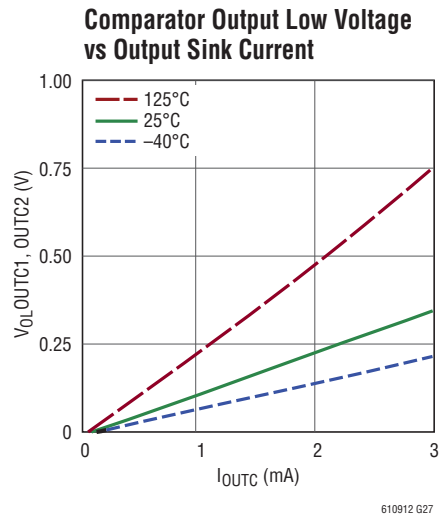
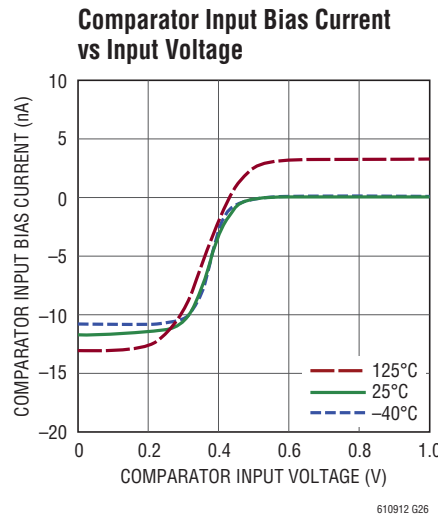
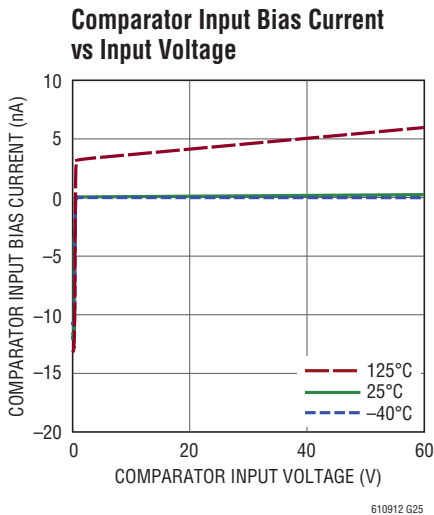
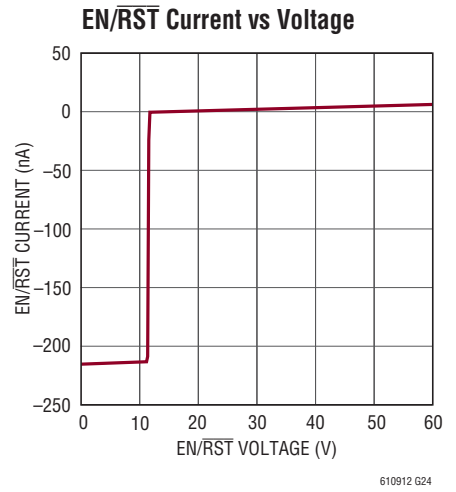
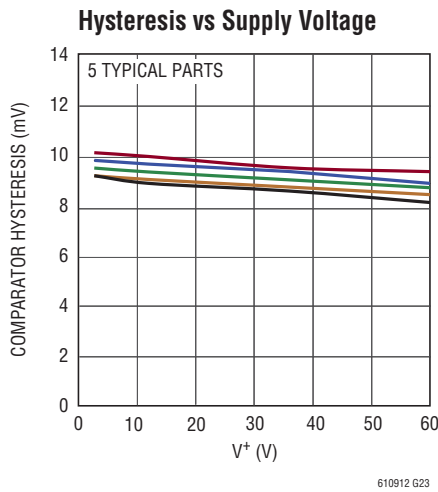
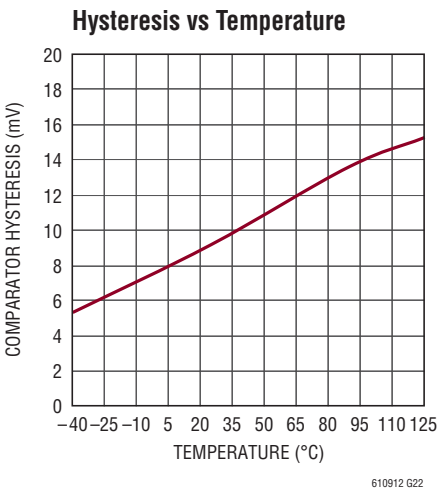
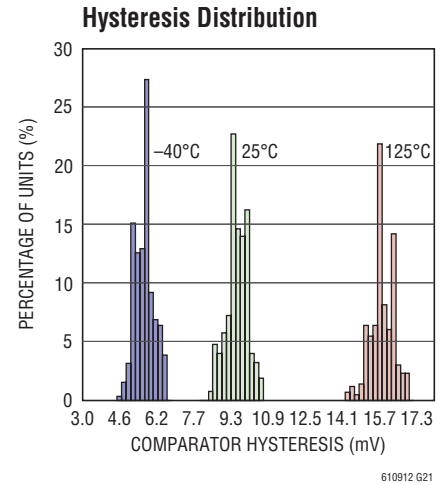
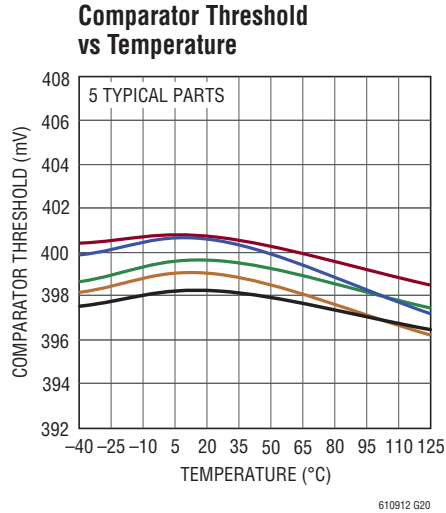
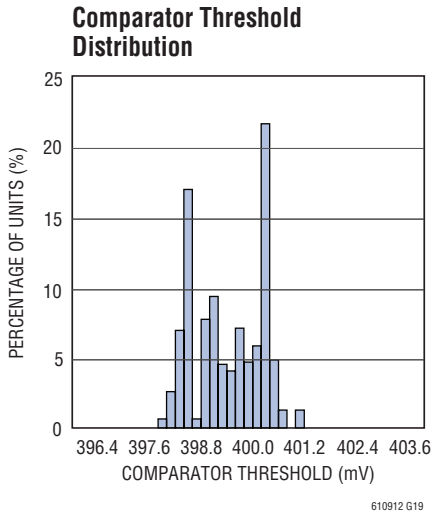

# LT6109-1/LT6109-2

**TYPICAL PERFORMANCE CHARACTERISTICS** Performance characteristics taken at  $T_A = 25^\circ\text{C}$ ,  $V^+ = 12\text{V}$ ,  $V_{\text{PULLUP}} = V^+$ ,  $V_{\text{EN/RST}} = 2.7\text{V}$ ,  $R_{\text{IN}} = 100\Omega$ ,  $R_{\text{OUT}} = R1 + R2 + R3 = 10\text{k}$ , gain = 100,  $R_C = 25.5\text{k}$ ,  $C_L = C_{LC} = 2\text{pF}$ , unless otherwise noted. (See Figure 3)

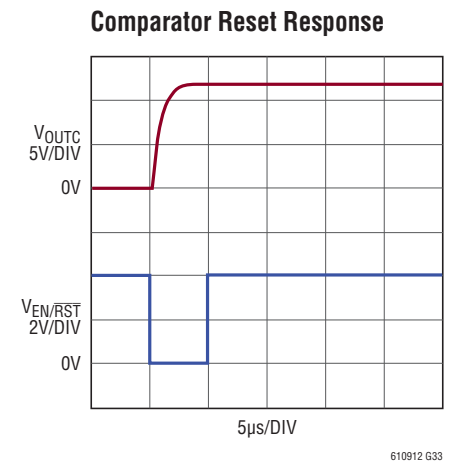
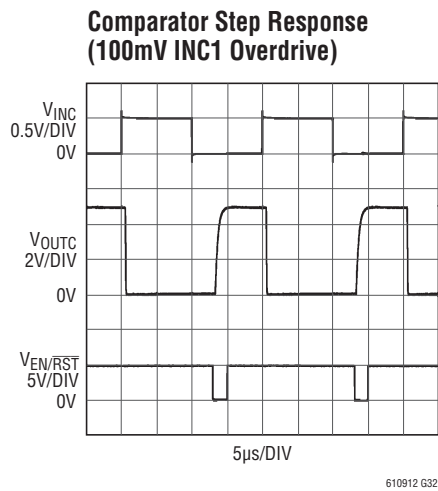
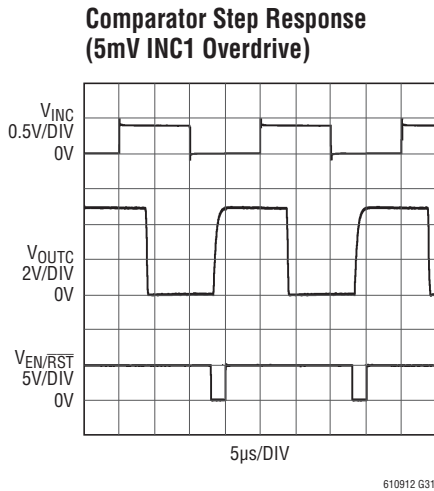
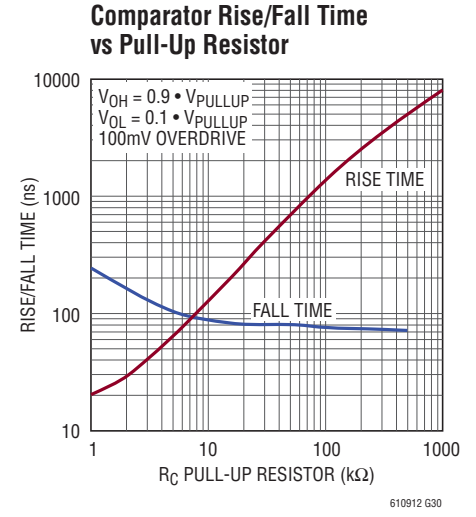
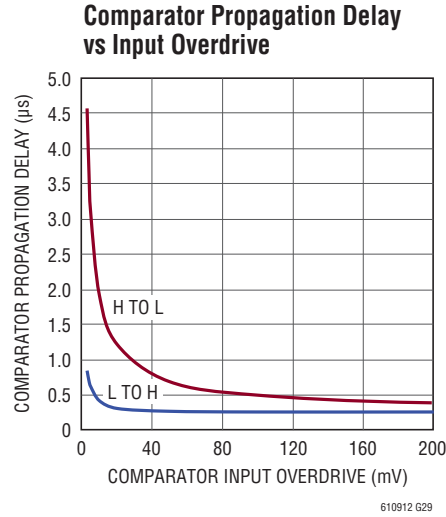
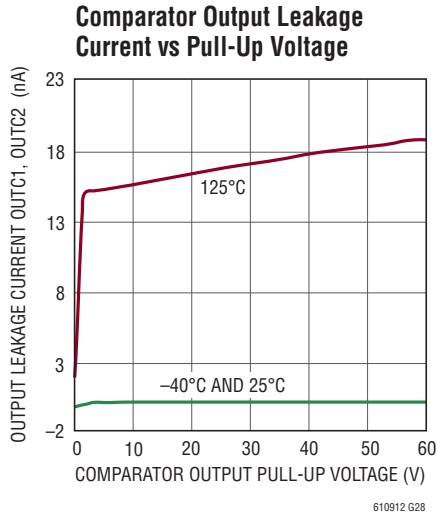

## PIN FUNCTIONS

**SENSELO (Pin 1):** Sense Amplifier Input. This pin must be tied to the load end of the sense resistor.

**EN/RST (Pin 2):** Enable/Comparator Reset Input. When low for longer than 150µs typically, the LT6109 will enter shutdown mode. Pulsing this pin low for between 2µs and 15µs will reset the comparators of the LT6109.

**OUTC2 (Pin 3):** Open-Drain Output for Comparator 2. Off-state voltage may be as high as 60V above ground, regardless of  $V^+$  used.

**OUTC1 (Pin 4):** Open-Drain Output for Comparator 1. Off-state voltage may be as high as 60V above ground, regardless of  $V^+$  used.

**$V^-$  (Pin 5):** Negative Supply Pin. This pin is normally connected to ground.

**INC1 (Pin 6):** Inverting Input of Comparator 1. The noninverting input is internally connected to the 400mV reference.



## PIN FUNCTIONS

**INC2 (Pin 7):** Input of Comparator 2. For the LT6109-1 this is the noninverting input of comparator 2. For the LT6109-2 this is the inverting input of comparator 2. The other comparator input is internally connected to the 400mV reference.

**OUTA (Pin 8):** Current Output of the Sense Amplifier. This pin will source a current that is equal to the sense voltage divided by the external gain setting resistor,  $R_{IN}$ .

**V<sup>+</sup> (Pin 9):** Positive Supply Pin. The V<sup>+</sup> pin can be connected directly to either side of the sense resistor,  $R_{SENSE}$ . When V<sup>+</sup> is tied to the load end of the sense resistor, the SENSEHI pin can go up to 0.2V above V<sup>+</sup>. Supply current is drawn through this pin.

**SENSEHI (Pin 10):** Sense Amplifier Input. The internal sense amplifier will drive SENSEHI to the same potential as SENSELO. A resistor (typically  $R_{IN}$ ) tied from V<sup>+</sup> to SENSEHI sets the output current,  $I_{OUT} = V_{SENSE}/R_{IN}$ , where  $V_{SENSE}$  is the voltage developed across  $R_{SENSE}$ .

## BLOCK DIAGRAMS

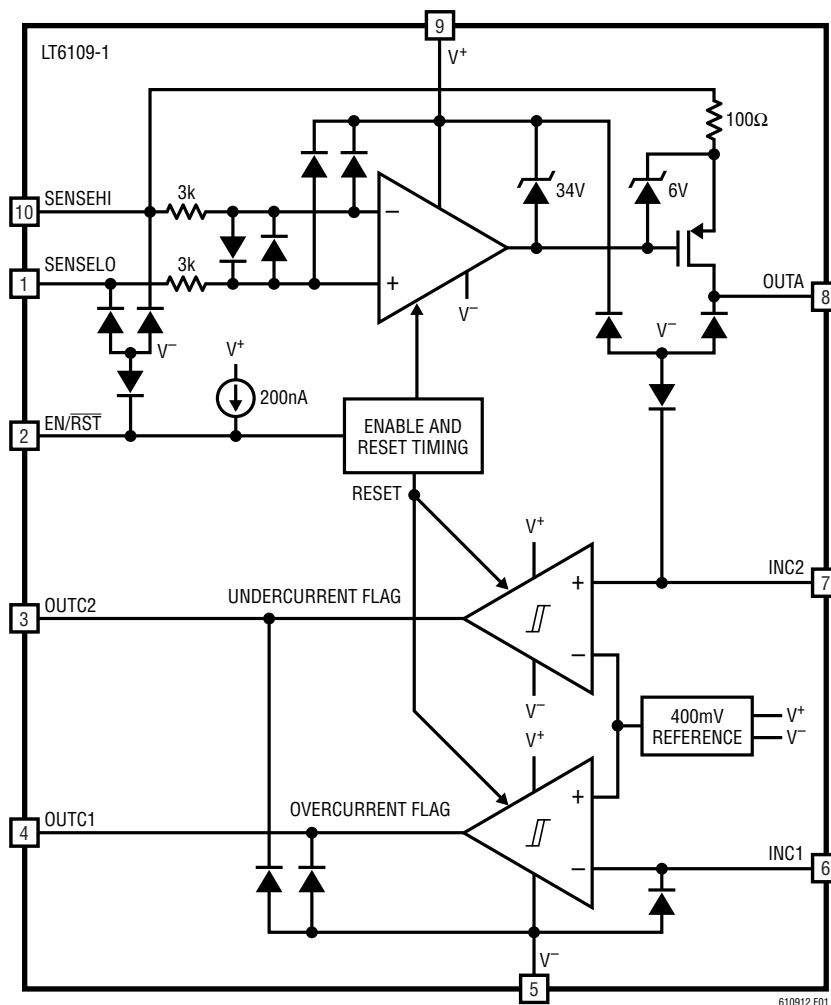

Figure 1. LT6109-1 Block Diagram (Comparators with Opposing Polarity)

**BLOCK DIAGRAMS**

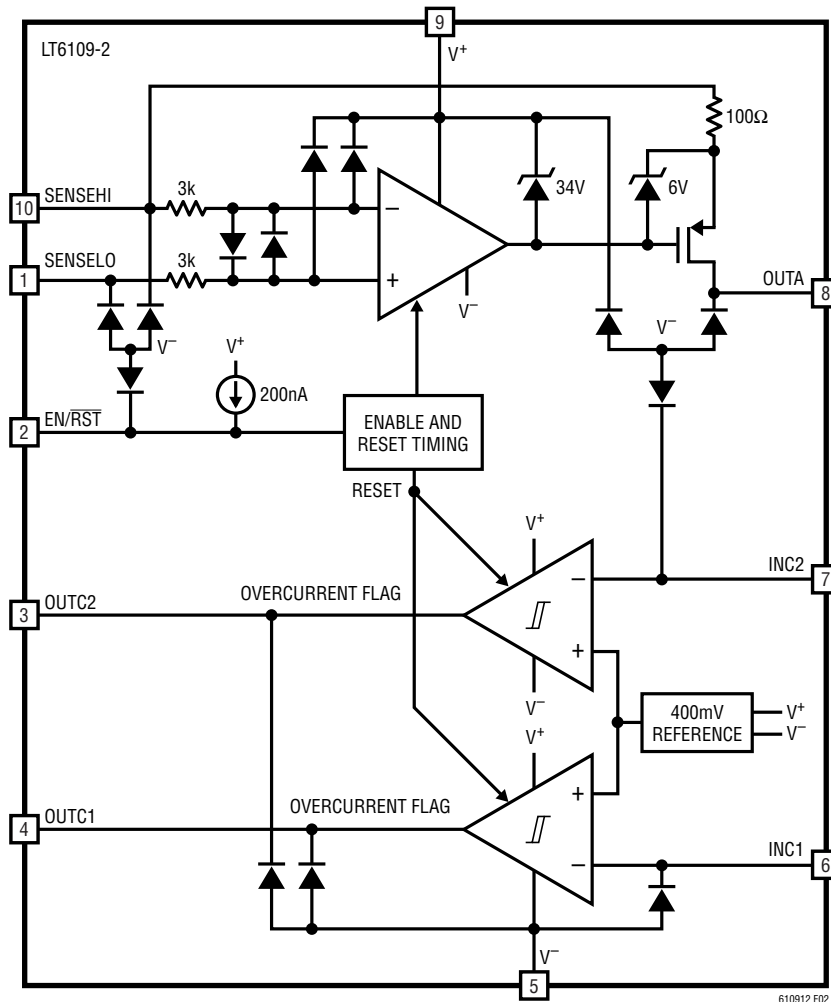

Figure 2. LT6109-2 Block Diagram (Comparators with the Same Polarity)

**APPLICATIONS INFORMATION**

The LT6109 high side current sense amplifier provides accurate monitoring of currents through an external sense resistor. The sensed voltage is amplified by an external resistor-set gain and level shifted from the positive power supply to a ground-referred output.

The LT6109 comparators have a threshold set with a built-in 400mV precision reference and have 10mV of hysteresis. The open-drain outputs can be easily used to level shift to digital supplies.

**Amplifier Theory of Operation**

An internal sense amplifier loop forces SENSEHI to have the same potential as SENSELO. Connecting an external resistor,  $R_{IN}$ , between SENSEHI and  $V^+$  forces a potential,  $V_{SENSE}$ , across  $R_{IN}$  that is the voltage appearing across  $R_{SENSE}$ . A corresponding current,  $I_{OUTA}$ , equal to  $V_{SENSE}/R_{IN}$ , will flow through  $R_{IN}$ . The high impedance inputs of the sense amplifier do not load this current, so it will flow through an internal MOSFET to the output pin, OUTA.

## APPLICATIONS INFORMATION

The output current can be transformed back into a voltage by adding a resistor from OUTA to V<sup>-</sup> (typically ground). The output voltage is then:

$$V_{OUT} = V^- + I_{OUTA} \cdot R_{OUT}$$

where  $R_{OUT} = R_1 + R_2 + R_3$  as shown in Figure 3.

**Table 1. Example Gain Configurations**

| GAIN | R <sub>IN</sub> | R <sub>OUT</sub> | V <sub>SENSE</sub> FOR V <sub>OUT</sub> = 5V | I <sub>OUTA</sub> AT V <sub>OUT</sub> = 5V |
|------|-----------------|------------------|--|--|
| 20   | 499Ω            | 10k              | 250mV  | 500μA                                      |
| 50   | 200Ω            | 10k              | 100mV  | 500μA                                      |
| 100  | 100Ω            | 10k              | 50mV   | 500μA                                      |

### Useful Equations

Input Voltage:  $V_{SENSE} = I_{SENSE} \cdot R_{SENSE}$

Voltage Gain:  $\frac{V_{OUT}}{V_{SENSE}} = \frac{R_{OUT}}{R_{IN}}$

Current Gain:  $\frac{I_{OUTA}}{I_{SENSE}} = \frac{R_{SENSE}}{R_{IN}}$

Note that  $V_{SENSE(MAX)}$  can be exceeded without damaging the amplifier, however, output accuracy will degrade as  $V_{SENSE}$  goes beyond  $V_{SENSE(MAX)}$ .

### Selection of External Current Sense Resistor

The external sense resistor,  $R_{SENSE}$ , has a significant effect on the function of a current sensing system and must be chosen with care.

First, the power dissipation in the resistor should be considered. The measured load current will cause power dissipation as well as a voltage drop in  $R_{SENSE}$ . As a result, the sense resistor should be as small as possible while still providing the input dynamic range required by the measurement. Note that the input dynamic range is the difference between the maximum input signal and the minimum accurately reproduced signal, and is limited primarily by input DC offset of the internal sense amplifier of the LT6109. To ensure the specified performance,  $R_{SENSE}$  should be small enough that  $V_{SENSE}$  does not exceed  $V_{SENSE(MAX)}$  under peak load conditions. As an example, an application may require the maximum sense voltage be 100mV. If this application is expected to draw 2A at peak load,  $R_{SENSE}$  should be set to 50mΩ.

Once the maximum  $R_{SENSE}$  value is determined, the minimum sense resistor value will be set by the resolution or dynamic range required. The minimum signal that can be accurately represented by this sense amplifier is limited by the input offset. As an example, the LT6109 has a maximum input offset of 350μV. If the minimum current is 20mA, a sense resistor of 17.5mΩ will set  $V_{SENSE}$  to 350μV. This is the same value as the input offset. A larger sense resistor will reduce the error due to offset by increasing the sense voltage for a given load current. Choosing a 50mΩ  $R_{SENSE}$  will maximize the dynamic range and provide a system that has 100mV across the sense resistor at peak load (2A), while input offset causes an error equivalent to only 7mA of load current.

In the previous example, the peak dissipation in  $R_{SENSE}$  is 200mW. If a 5mΩ sense resistor is employed, then the effective current error is 70mA, while the peak sense voltage is reduced to 10mV at 2A, dissipating only 20mW.

The low offset and corresponding large dynamic range of the LT6109 make it more flexible than other solutions in this respect. The 350μV maximum offset gives 63dB of dynamic range for a sense voltage that is limited to 500mV max.

### Sense Resistor Connection

Kelvin connection of the SENSEHI and SENSELO inputs to the sense resistor should be used in all but the lowest power applications. Solder connections and PC board interconnections that carry high current can cause significant error in measurement due to their relatively large resistances. One 10mm × 10mm square trace of 1oz copper is approximately 0.5mΩ. A 1mV error can be caused by as little as 2A flowing through this small interconnect. This will cause a 1% error for a full-scale  $V_{SENSE}$  of 100mV. A 10A load current in the same interconnect will cause a 5% error for the same 100mV signal. By isolating the sense traces from the high current paths, this error can be reduced by orders of magnitude. A sense resistor with integrated Kelvin sense terminals will give the best results. Figure 3 illustrates the recommended method for connecting the SENSEHI and SENSELO pins to the sense resistor.

APPLICATIONS INFORMATION

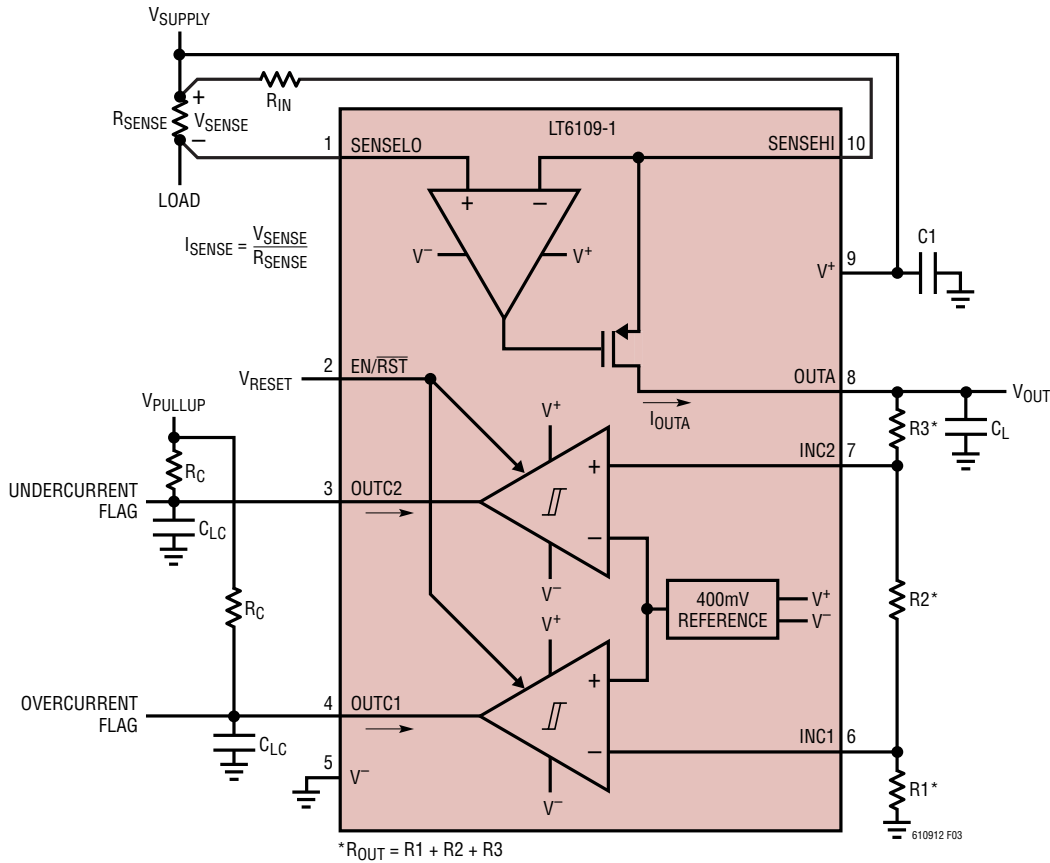

Figure 3. LT6109-1 Typical Connection

Selection of External Input Resistor, R<sub>IN</sub>

R<sub>IN</sub> should be chosen to allow the required speed and resolution while limiting the output current to 1mA. The maximum value for R<sub>IN</sub> is 1k to maintain good loop stability. For a given V<sub>SENSE</sub>, larger values of R<sub>IN</sub> will lower power dissipation in the LT6109 due to the reduction in I<sub>OUT</sub> while smaller values of R<sub>IN</sub> will result in faster response time due to the increase in I<sub>OUT</sub>. If low sense currents must be resolved accurately in a system that has a very wide dynamic range, a smaller R<sub>IN</sub> may be used if the maximum I<sub>OUTA</sub> current is limited in another way, such as with a Schottky diode across R<sub>SENSE</sub> (Figure 4). This will reduce the high current measurement accuracy by limiting the result, while increasing the low current measurement resolution.

This approach can be helpful in cases where occasional bursts of high currents can be ignored.

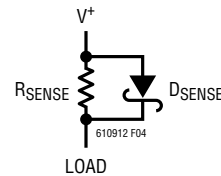

Figure 4. Shunt Diode Limits Maximum Input Voltage to Allow Better Low Input Resolution Without Overranging

Care should be taken when designing the board layout for R<sub>IN</sub>, especially for small R<sub>IN</sub> values. All trace and interconnect resistances will increase the effective R<sub>IN</sub> value, causing a gain error.

The power dissipated in the sense resistor can cause a significant thermal gradient and consequently a gain error if R<sub>IN</sub> and R<sub>OUT</sub> are placed such that they can operate at different temperatures. If significant power is being dissipated in the sense resistor then care should be taken

## APPLICATIONS INFORMATION

to place  $R_{IN}$  and  $R_{OUT}$  such that the gain error due to the thermal gradient is minimized.

### Selection of External Output Resistor, $R_{OUT}$

The output resistor,  $R_{OUT}$ , determines how the output current is converted to voltage.  $V_{OUT}$  is simply  $I_{OUTA} \cdot R_{OUT}$ . Typically,  $R_{OUT}$  is a combination of resistors configured as a resistor divider which has voltage taps going to the comparator inputs to set the comparator thresholds.

In choosing an output resistor, the maximum output voltage must first be considered. If the subsequent circuit is a buffer or ADC with limited input range, then  $R_{OUT}$  must be chosen so that  $I_{OUTA(MAX)} \cdot R_{OUT}$  is less than the allowed maximum input range of this circuit.

In addition, the output impedance is determined by  $R_{OUT}$ . If another circuit is being driven, then the input impedance of that circuit must be considered. If the subsequent circuit has high enough input impedance, then almost any useful output impedance will be acceptable. However, if the subsequent circuit has relatively low input impedance, or draws spikes of current such as an ADC load, then a lower output impedance may be required to preserve the accuracy of the output. More information can be found in the Output Filtering section. As an example, if the input impedance of the driven circuit,  $R_{IN(DRIVEN)}$ , is 100 times  $R_{OUT}$ , then the accuracy of  $V_{OUT}$  will be reduced by 1% since:

$$\begin{aligned} V_{OUT} &= I_{OUTA} \cdot \frac{R_{OUT} \cdot R_{IN(DRIVEN)}}{R_{OUT} + R_{IN(DRIVEN)}} \\ &= I_{OUTA} \cdot R_{OUT} \cdot \frac{100}{101} = 0.99 \cdot I_{OUTA} \cdot R_{OUT} \end{aligned}$$

### Amplifier Error Sources

The current sense system uses an amplifier and resistors to apply gain and level-shift the result. Consequently, the output is dependent on the characteristics of the amplifier, such as gain error and input offset, as well as the matching of the external resistors.

Ideally, the circuit output is:

$$V_{OUT} = V_{SENSE} \cdot \frac{R_{OUT}}{R_{IN}}; \quad V_{SENSE} = R_{SENSE} \cdot I_{SENSE}$$

In this case, the only error is due to external resistor mismatch, which provides an error in gain only. However, offset voltage, input bias current and finite gain in the amplifier can cause additional errors:

### Output Voltage Error, $\Delta V_{OUT(VOS)}$ , Due to the Amplifier DC Offset Voltage, $V_{OS}$

$$\Delta V_{OUT(VOS)} = V_{OS} \cdot \frac{R_{OUT}}{R_{IN}}$$

The DC offset voltage of the amplifier adds directly to the value of the sense voltage,  $V_{SENSE}$ . As  $V_{SENSE}$  is increased, accuracy also improves. This is the dominant error of the system and it limits the available dynamic range.

### Output Voltage Error, $\Delta V_{OUT(IBIAS)}$ , Due to the Bias Currents $I_{B^+}$ and $I_{B^-}$

The amplifier bias current  $I_{B^+}$  flows into the SENSELO pin while  $I_{B^-}$  flows into the SENSEHI pin. The error due to  $I_B$  is the following:

$$\Delta V_{OUT(IBIAS)} = R_{OUT} \left( I_{B^+} \cdot \frac{R_{SENSE}}{R_{IN}} - I_{B^-} \right)$$

Since  $I_{B^+} \approx I_{B^-} = I_{BIAS}$ , if  $R_{SENSE} \ll R_{IN}$  then,

$$\Delta V_{OUT(IBIAS)} = -R_{OUT} (I_{BIAS})$$

It is useful to refer the error to the input:

$$\Delta V_{IN(IBIAS)} = -R_{IN} (I_{BIAS})$$

For instance, if  $I_{BIAS}$  is 100nA and  $R_{IN}$  is 1k, the input referred error is 100 $\mu$ V. This error becomes less significant as the value of  $R_{IN}$  decreases. The bias current error can be reduced if an external resistor,  $R_{IN^+}$ , is connected as shown in Figure 5, the error is then reduced to:

$$V_{OUT(IBIAS)} = \pm R_{OUT} \cdot I_{OS}; \quad I_{OS} = I_{B^+} - I_{B^-}$$

Adding  $R_{IN^+}$  as described will maximize the dynamic range of the circuit as shown in Figure 5.

**APPLICATIONS INFORMATION**

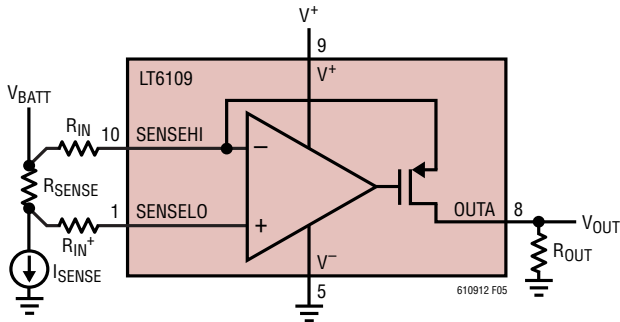

Figure 5.  $R_{IN+}$  Reduces Error Due to  $I_B$

**Output Voltage Error,  $\Delta V_{OUT(GAIN ERROR)}$ , Due to External Resistors**

The LT6109 exhibits a very low gain error. As a result, the gain error is determined primarily by the accuracy of the external resistors used to set the gain. For instance, if 0.1% resistors are used for  $R_{IN}$  and  $R_{OUT}$  then the resulting worst-case gain error is 0.4% with  $R_{IN} = 100\Omega$ . Figure 6 is a graph of the maximum gain error which can be expected versus the external resistor tolerance.

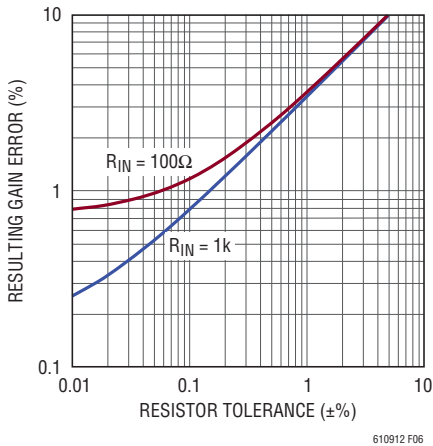

Figure 6. Gain Error vs Resistor Tolerance

**Output Current Limitations Due to Power Dissipation**

The LT6109 can deliver a continuous current of 1mA to the OUTA pin. This current flows through  $R_{IN}$  and enters the current sense amplifier via the SENSEHI pin. The power dissipated in the LT6109 due to the output signal is:

$$P_{OUT} = (V_{SENSEHI} - V_{OUTA}) \cdot I_{OUTA}$$

$$\text{Since } V_{SENSEHI} \approx V^+, P_{OUTA} \approx (V^+ - V_{OUTA}) \cdot I_{OUTA}$$

There is also power dissipated due to the quiescent power supply current:

$$P_S = I_S \cdot V^+$$

The comparator output current flows into the comparator output pin and out of the  $V^-$  pin. The power dissipated in the LT6109 due to each comparator is often insignificant and can be calculated as follows:

$$P_{OUTC1,C2} = (V_{OUTC1,C2} - V^-) \cdot I_{OUTC1,C2}$$

The total power dissipated is the sum of these dissipations:

$$P_{TOTAL} = P_{OUTA} + P_{OUTC1} + P_{OUTC2} + P_S$$

At maximum supply and maximum output currents, the total power dissipation can exceed 100mW. This will cause significant heating of the LT6109 die. In order to prevent damage to the LT6109, the maximum expected dissipation in each application should be calculated. This number can be multiplied by the  $\theta_{JA}$  value, 160°C/W, to find the maximum expected die temperature. Proper heat sinking and thermal relief should be used to ensure that the die temperature does not become excessive.

**Output Filtering**

The AC output voltage,  $V_{OUT}$ , is simply  $I_{OUTA} \cdot Z_{OUT}$ . This makes filtering straightforward. Any circuit may be used which generates the required  $Z_{OUT}$  to get the desired filter response. For example, a capacitor in parallel with  $R_{OUT}$  will give a lowpass response. This will reduce unwanted noise from the output, and may also be useful as a charge reservoir to keep the output steady while driving a switching circuit such as a MUX or ADC. This output capacitor in parallel with  $R_{OUT}$  will create an output pole at:

$$f_{-3dB} = \frac{1}{2 \cdot \pi \cdot R_{OUT} \cdot C_L}$$

**SENSELO, SENSEHI Range**

The difference between  $V_{BATT}$  (see Figure 7) and  $V^+$ , as well as the maximum value of  $V_{SENSE}$ , must be considered to ensure that the SENSELO pin doesn't exceed the range listed in the Electrical Characteristics table. The SENSELO and SENSEHI pins of the LT6109 can function from 0.2V

## APPLICATIONS INFORMATION

above the positive supply to 33V below it. These operating voltages are limited by internal diode clamps shown in Figures 1 and 2. On supplies less than 35.5V, the lower range is limited by  $V^- + 2.5V$ . This allows the monitored supply,  $V_{BATT}$ , to be separate from the LT6109 positive supply as shown in Figure 7. Figure 8 shows the range of operating voltages for the SENSELO and SENSEHI inputs, for different supply voltage inputs ( $V^+$ ). The SENSELO and SENSEHI range has been designed to allow the LT6109 to monitor its own supply current (in addition to the load), as long as  $V_{SENSE}$  is less than 200mV. This is shown in Figure 9.

### Minimum Output Voltage

The output of the LT6109 current sense amplifier can produce a non-zero output voltage when the sense voltage is zero. This is a result of the sense amplifier  $V_{OS}$  being forced across  $R_{IN}$  as discussed previously in the Output Voltage Error,  $\Delta V_{OUT(VOS)}$  section. Figure 10 shows the effect of the input offset voltage on the transfer function for parts at the  $V_{OS}$  limits. With a negative offset voltage, zero input sense voltage produces an output voltage. With a positive offset voltage, the output voltage is zero until the input sense voltage exceeds the input offset voltage. Neglecting  $V_{OS}$ , the output circuit is not limited by saturation of pull-down circuitry and can reach 0V.

### Response Time

The LT6109 amplifier is designed to exhibit fast response to inputs for the purpose of circuit protection or current monitoring. This response time will be affected by the external components in two ways, delay and speed.

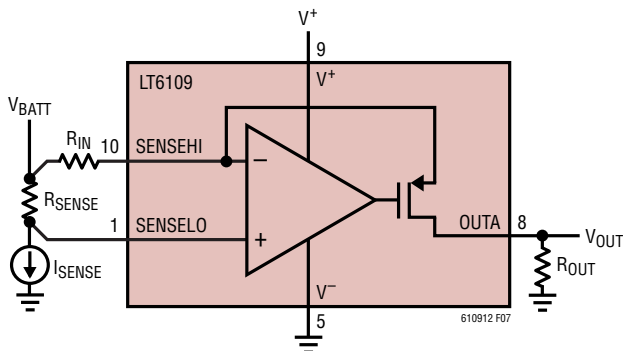

Figure 7.  $V^+$  Powered Separately from Load Supply ( $V_{BATT}$ )

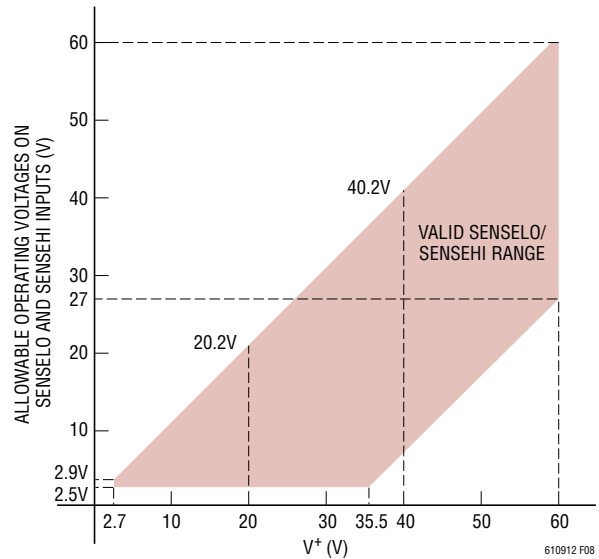

Figure 8. Allowable SENSELO, SENSEHI Voltage Range

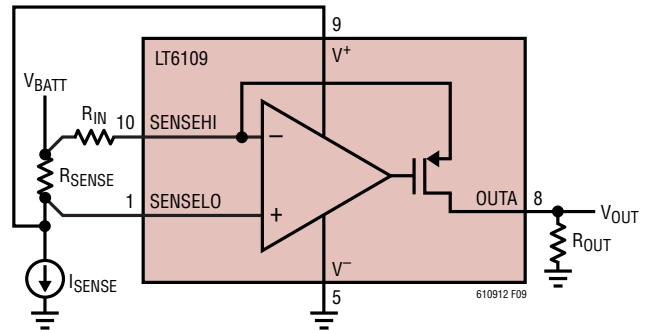

Figure 9. LT6109 Supply Current Monitored with Load

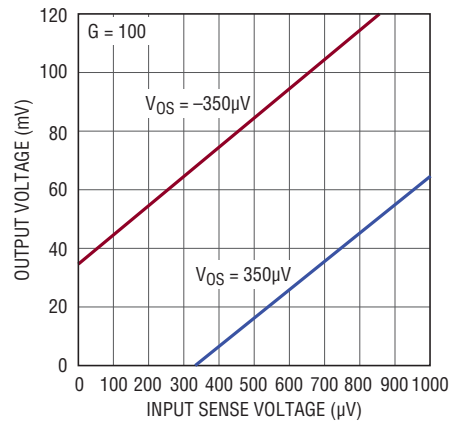

Figure 10. Amplifier Output Voltage vs Input Sense Voltage

## APPLICATIONS INFORMATION

If the output current is very low and an input transient occurs, there may be an increased delay before the output voltage begins to change. The Typical Performance Characteristics show that this delay is short and it can be improved by increasing the minimum output current, either by increasing  $R_{SENSE}$  or decreasing  $R_{IN}$ . Note that the Typical Performance Characteristics are labeled with respect to the initial sense voltage.

The speed is also affected by the external components. Using a larger  $R_{OUT}$  will decrease the response time, since  $V_{OUT} = I_{OUTA} \cdot Z_{OUT}$  where  $Z_{OUT}$  is the parallel combination of  $R_{OUT}$  and any parasitic and/or load capacitance. Note that reducing  $R_{IN}$  or increasing  $R_{OUT}$  will both have the effect of increasing the voltage gain of the circuit. If the output capacitance is limiting the speed of the system,  $R_{IN}$  and  $R_{OUT}$  can be decreased together in order to maintain the desired gain and provide more current to charge the output capacitance.

The response time of the comparators is the sum of the propagation delay and the fall time. The propagation delay is a function of the overdrive voltage on the input of the comparators. A larger overdrive will result in a lower propagation delay. This helps achieve a fast system response time to fault events. The fall time is affected by the load on the output of the comparator as well as the pull-up voltage.

The LT6109 amplifier has a typical response time of 500ns and the comparators have a typical response time of 700ns. When configured as a system, the amplifier output drives the comparator input causing a total system response time which is typically greater than that implied by the individually specified response times. This is due to the overdrive on the comparator input being determined by the speed of the amplifier output.

### Internal Reference and Comparators

The integrated precision reference and comparators combined with the high precision current sense allow for rapid and easy detection of abnormal load currents. This is often critical in systems that require high levels of safety and reliability. The LT6109 comparators are optimized for fault detection and are designed with latching outputs. Latching outputs prevent faults from clearing themselves and

require a separate system or user to reset the outputs. In applications where the comparator output can intervene and disconnect loads from the supply, latched outputs are required to avoid oscillation. Latching outputs are also useful for detecting problems that are intermittent. The comparator outputs on the LT6109 are always latching and there is no way to disable this feature.

Each of the comparators has one input available externally, with the two versions of the part differing by the polarity of those available inputs. The other comparator inputs are connected internally to the 400mV precision reference. The input threshold (the voltage which causes the output to transition from high to low) is designed to be equal to that of the reference. The reference voltage is established with respect to the device  $V^-$  connection.

### Comparator Inputs

The comparator inputs can swing from  $V^-$  to 60V regardless of the supply voltage used. The input current for inputs well above the threshold is just a few pAs. With decreasing input voltage, a small bias current begins to be drawn out of the input near the threshold, reaching 50nA max when at ground potential. Note that this change in input bias current can cause a small nonlinearity in the OUTA transfer function if the comparator inputs are coupled to the amplifier output with a voltage divider. For example, if the maximum comparator input current is 50nA, and the resistance seen looking out of the comparator input is 1k, then a change in output voltage of 50 $\mu$ V will be seen on the analog output when the comparator input voltage passes through its threshold. If both comparator inputs are connected to the output then they must both be considered.

### Setting Comparator Thresholds

The comparators have an internal precision 400mV reference. In order to set the trip points of the LT6109-1 comparators, the output currents,  $I_{OVER}$  and  $I_{UNDER}$ , as well as the maximum output current,  $I_{MAX}$ , must be calculated:

$$I_{OVER} = \frac{V_{SENSE(OVER)}}{R_{IN}}, \quad I_{UNDER} = \frac{V_{SENSE(UNDER)}}{R_{IN}},$$

$$I_{MAX} = \frac{V_{SENSE(MAX)}}{R_{IN}}$$



## APPLICATIONS INFORMATION

where  $I_{OVER}$  and  $I_{UNDER}$  are the over and under currents through the sense resistor which cause the comparators to trip.  $I_{MAX}$  is the maximum current through the sense resistor.

Depending on the desired maximum amplifier output voltage ( $V_{MAX}$ ) the three output resistors, R1, R2 and R3, can be configured in two ways. If:

$$V_{MAX} > \left[ \frac{400mV}{I_{OVER}} + \frac{400mV - I_{UNDER}(R1)}{I_{UNDER}} \right] I_{MAX}$$

then use the configuration shown in Figure 3. The desired trip points and full-scale analog output voltage for the circuit in Figure 3 can then be achieved using the following equations:

$$R1 = \frac{400mV}{I_{OVER}}$$

$$R2 = \frac{400mV - I_{UNDER}(R1)}{I_{UNDER}}$$

$$R3 = \frac{V_{MAX} - I_{MAX}(R1 + R2)}{I_{MAX}}$$

If:

$$V_{MAX} < \left[ \frac{400mV}{I_{OVER}} + \frac{400mV - I_{UNDER}(R1)}{I_{UNDER}} \right] I_{MAX}$$

then use the configuration shown in Figure 11.

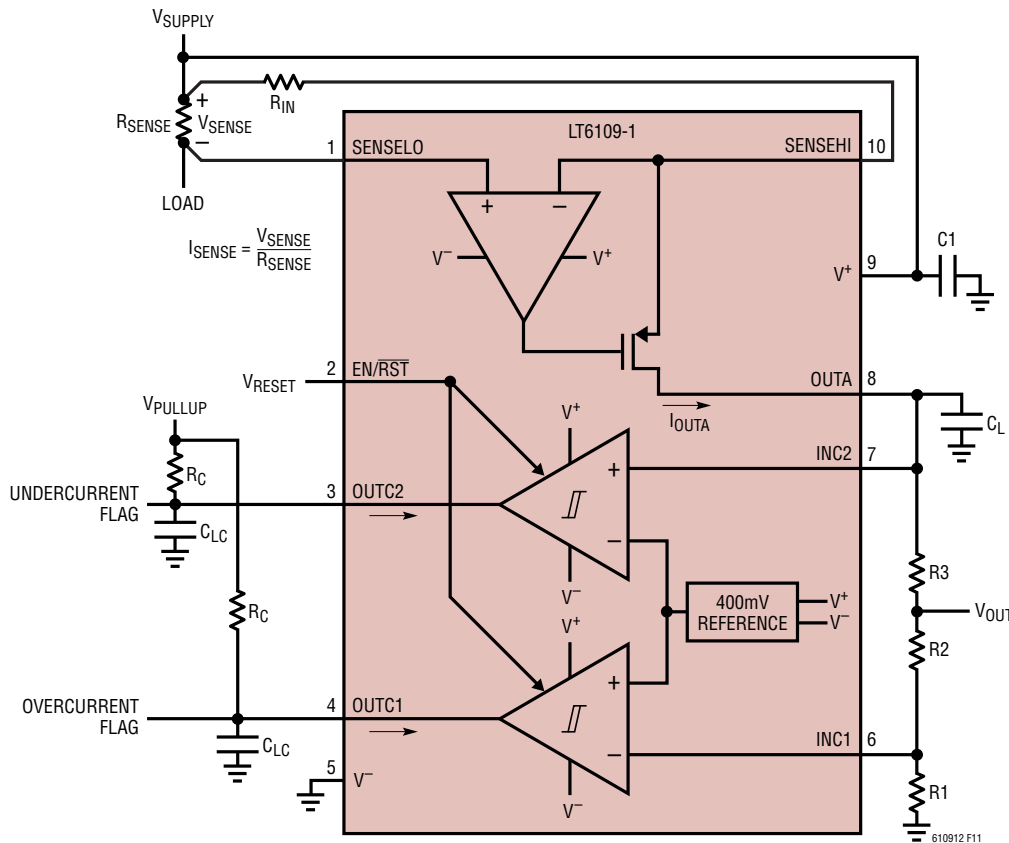

Figure 11. Typical Configuration with Alternative  $R_{OUT}$  Configuration

## APPLICATIONS INFORMATION

The desired trip points and full-scale analog output voltage for the circuit in Figure 13 can be achieved as follows:

$$R1 = \frac{400\text{mV}}{I_{\text{OVER}}}$$

$$R2 = \frac{V_{\text{MAX}} - I_{\text{MAX}}(R1)}{I_{\text{MAX}}}$$

$$R3 = \frac{400\text{mV} - I_{\text{UNDER}}(R1 + R2)}{I_{\text{UNDER}}}$$

Trip points for the LT6109-2 can be set by replacing  $I_{\text{UNDER}}$  with a second overcurrent,  $I_{\text{OVER}2}$ .

### Hysteresis

Each comparator has a built-in hysteresis of 10mV typically to simplify design, ensure stable operation in the presence of noise at the inputs, and to reject supply noise that might be induced by state change load transients. The hysteresis is designed such that the threshold voltage is altered when the output is transitioning from low to high as is shown in Figure 12.

External positive feedback circuitry can be employed to increase the effective hysteresis if desired, but such circuitry will have an effect on both the rising and fall-

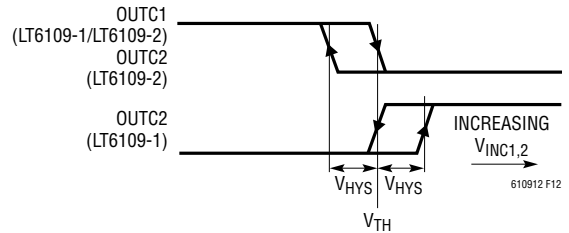

Figure 12. Comparator Output Transfer Characteristics

ing input thresholds,  $V_{\text{TH}}$  (the actual internal threshold remains unaffected).

Figure 13 shows how to add additional hysteresis to a noninverting comparator.

$R6$  can be calculated from the extra hysteresis being added,  $V_{\text{HYS(EXTA)}}$  and the amplifier output current which you want to cause the comparator output to trip,  $I_{\text{UNDER}}$ . Note that the hysteresis being added,  $V_{\text{HYS(EXTA)}}$ , is in addition to the typical 10mV of built-in hysteresis.

$$R6 = \frac{400\text{mV} - V_{\text{HYS(EXTA)}}}{I_{\text{UNDER}}}$$

$R1$  should be chosen such that  $R1 \gg R6$  so that  $V_{\text{OUTA}}$  does not change significantly when the comparator trips.

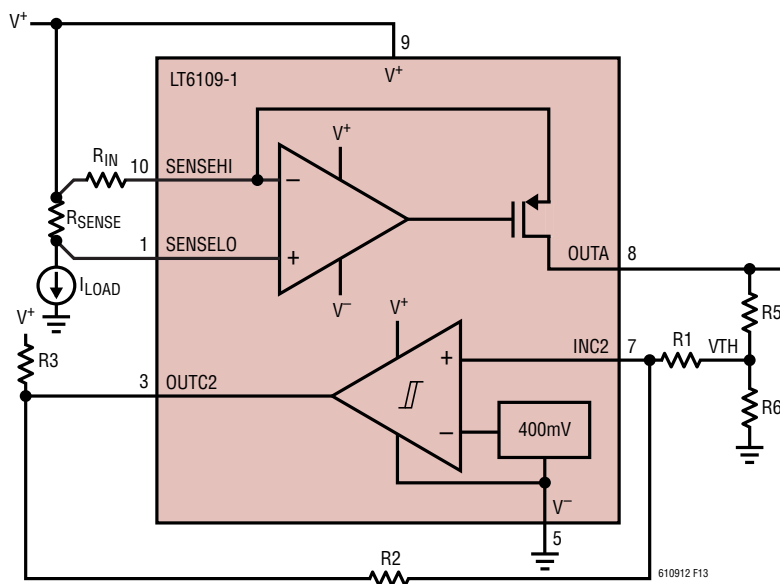

Figure 13. Noninverting Comparator with Added Hysteresis

## APPLICATIONS INFORMATION

R3 should be chosen to allow sufficient  $V_{OL}$  and comparator output rise time due to capacitive loading.

R2 can be calculated:

$$R2 = \frac{R1 \cdot (V^+ - 400mV) - (V_{HYS(EXTRA)} \cdot R3)}{V_{HYS(EXTRA)}}$$

For very large values of R2 PCB related leakage may become an issue. A tee network can be implemented to reduce the required resistor values.

The approximate total hysteresis will be:

$$V_{HYS} = 10mV + R1 \cdot \left( \frac{V^+ - 400mV}{R2 + R3} \right)$$

For example, to achieve  $I_{UNDER} = 100\mu A$  with 50mV of total hysteresis,  $R6 = 3.57k$ . Choosing  $R1 = 35.7k$ ,  $R3 = 10k$  and  $V^+ = 5V$  results in  $R2 = 4.12M$ .

The analog output voltage will also be affected when the comparator trips due to the current injected into R6 by the positive feedback. Because of this, it is desirable to have  $(R1 + R2 + R3) \gg R6$ . The maximum  $V_{OUTA}$  error caused by this can be calculated as:

$$\Delta V_{OUTA} = V^+ \cdot \left( \frac{R6}{R1 + R2 + R3 + R6} \right)$$

In the previous example, this is an error of 4.3mV at the output of the amplifier or 43μV at the input of the amplifier assuming a gain of 100.

When using the comparators with their inputs decoupled from the output of the amplifier, they may be driven directly by a voltage source. It is useful to know the threshold voltage equations with the additional hysteresis. The input falling edge threshold which causes the output to transition from high to low is:

$$V_{TH(F)} = 400mV \cdot R1 \cdot \left( \frac{1}{R1} + \frac{1}{R2 + R3} \right) - \left( \frac{V^+ \cdot R1}{R2 + R3} \right)$$

The input rising edge threshold which causes the output to transition from low to high is:

$$V_{TH(R)} = 410mV \cdot R1 \cdot \left( \frac{1}{R1} + \frac{1}{R2} \right)$$

Figure 14 shows how to add additional hysteresis to an inverting comparator.

R7 can be calculated from the amplifier output current which is required to cause the comparator output to trip,  $I_{OVER}$ .

$$R7 = \frac{400mV}{I_{OVER}}, \text{ Assuming } (R1 + R2) \gg R7$$

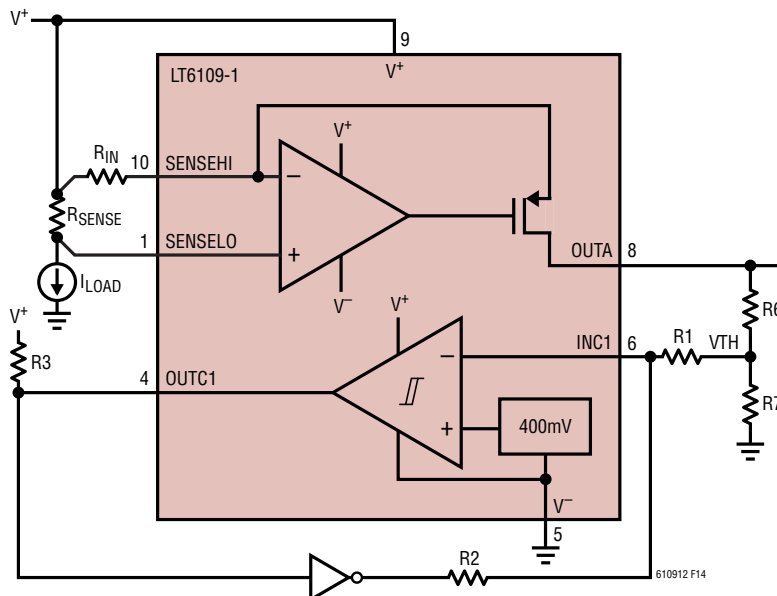

Figure 14. Inverting Comparator with Added Hysteresis

## APPLICATIONS INFORMATION

R1 should be chosen such that  $R1 \gg R7$  so that  $V_{OUTA}$  does not change significantly when the comparator trips.

R3 should be chosen to allow sufficient  $V_{OL}$  and comparator output rise time due to capacitive loading.

R2 can be calculated:

$$R2 = R1 \cdot \left( \frac{V^+ - 390\text{mV}}{V_{\text{HYS(EXTRA)}}} \right)$$

Note that the hysteresis being added,  $V_{\text{HYS(EXTRA)}}$ , is in addition to the typical 10mV of built-in hysteresis. For very large values of R2 PCB related leakage may become an issue. A tee network can be implemented to reduce the required resistor values.

The approximate total hysteresis is:

$$V_{\text{HYS}} = 10\text{mV} + R1 \cdot \left( \frac{V^+ - 390\text{mV}}{R2} \right)$$

For example, to achieve  $I_{\text{OVER}} = 900\mu\text{A}$  with 50mV of total hysteresis,  $R7 = 442\Omega$ . Choosing  $R1 = 4.42\text{k}$ ,  $R3 = 10\text{k}$  and  $V^+ = 5\text{V}$  results in  $R2 = 513\text{k}$ .

The analog output voltage will also be affected when the comparator trips due to the current injected into R7 by the positive feedback. Because of this, it is desirable to have  $(R1 + R2) \gg R7$ . The maximum  $V_{\text{OUTA}}$  error caused by this can be calculated as:

$$\Delta V_{\text{OUTA}} = V^+ \cdot \left( \frac{R7}{R1 + R2 + R7} \right)$$

In the previous example, this is an error of 4.3mV at the output of the amplifier or  $43\mu\text{V}$  at the input of the amplifier assuming a gain of 100.

When using the comparators with their inputs decoupled from the output of the amplifier they may be driven directly by a voltage source. It is useful to know the threshold voltage equations with additional hysteresis. The input rising edge threshold which causes the output to transition from high to low is:

$$V_{\text{TH(R)}} = 400\text{mV} \cdot R1 \cdot \left( \frac{1}{R1} + \frac{1}{R2} \right)$$

The input falling edge threshold which causes the output to transition from low to high is:

$$V_{\text{TH(F)}} = 390\text{mV} \cdot R1 \cdot \left( \frac{1}{R1} + \frac{1}{R2} \right) - \left( \frac{V^+ \cdot R1}{R2} \right)$$

### Comparator Outputs

The comparator outputs can maintain a logic low level of 150mV while sinking 500 $\mu\text{A}$ . The outputs can supply higher currents at elevated  $V_{\text{OL}}$  levels as shown in the Typical Performance Characteristics. Load currents are conducted to the  $V^-$  pin. The output off-state voltage may range between 0V and 60V with respect to  $V^-$ , regardless of the supply voltage used. As with any open-drain device, the outputs may be tied together to implement wire-OR logic functions. The LT6109-1 can be used as a single-output window comparator in this way.

### EN/ $\overline{\text{RST}}$ Pin

The EN/ $\overline{\text{RST}}$  pin performs the two functions of resetting the latch on the comparators as well as shutting down the LT6109.

Applying a pulse to the EN/ $\overline{\text{RST}}$  pin will reset the comparators from their tripped state as long as the input on the comparator is below the threshold and hysteresis for an inverting comparator or above the threshold and hysteresis for a noninverting comparator. For example, if  $V_{\text{INC1}}$  is pulled higher than 400mV and latches the comparator, a reset pulse will not reset that comparator unless its input is held below the threshold by a voltage greater than the 10mV typical hysteresis.

Figure 15 shows the reset functionality of the EN/ $\overline{\text{RST}}$  pin. The width of the pulse applied to reset the comparators must be greater than  $t_{\text{RPW(MIN)}}$  (2 $\mu\text{s}$ ) but less than  $t_{\text{RPW(MAX)}}$  (15 $\mu\text{s}$ ). Applying a pulse that is longer than 40 $\mu\text{s}$  typically (or tying the pin low) will cause the part to enter shutdown. Once the part has entered shutdown, the supply current will be reduced to 6 $\mu\text{A}$  typically and the amplifier, comparators and reference will cease to function until the EN/ $\overline{\text{RST}}$  pin is transitioned high. When the part is disabled, both the amplifier and comparator outputs are high impedance.

## APPLICATIONS INFORMATION

When the EN/RST pin is transitioned from low to high to enable the part, the amplifier output PMOS can turn on momentarily causing current to flow into the SENSEHI pin and out of the OUTA pin. Once the amplifier is entirely turned on, the output will go to the correct current. Figure 16 shows this behavior and the impact it has on  $V_{OUTA}$ . Circuitry connected to OUTA can be protected from these transients by using an external diode to clamp  $V_{OUTA}$  or a capacitor to filter  $V_{OUTA}$ .

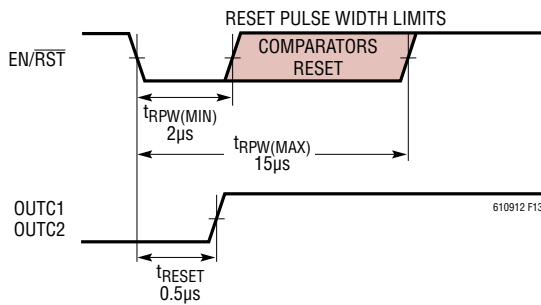

Figure 15. Comparator Reset Functionality

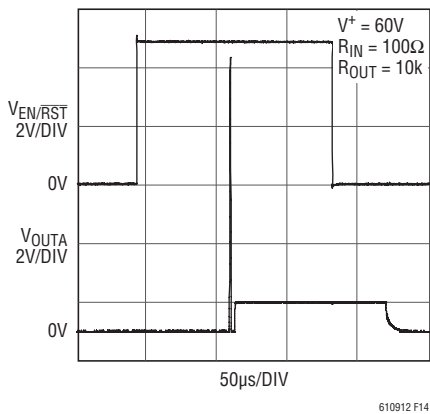

Figure 16. Amplifier Enable Response

### Power Up

After powering on the LT6109, the comparators must be reset in order to guarantee a valid state at their outputs. Fast supply ramps may cause a supply current transient during start-up as shown in the Typical Performance Characteristics. This current can be lowered by reducing the edge speed of the supply.

### Reverse-Supply Protection

Some applications may encounter reverse-polarity supplies. The LT6109 is not protected from a reversal of supply polarity.

### Error Budget

This current sense amplifier (Figure 17) operates by using an amplifier to replicate the sense voltage across an external resistor,  $R_{IN}$ . The resulting current through  $R_{IN}$  is conveyed through an output FET to an external resistor,  $R_{OUT}$ , to produce an output voltage. The gain is set by the ratio of  $R_{OUT}/R_{IN}$ . This section will describe how various error sources contribute to the system accuracy of the circuit shown in Figure 17. Note the second comparator has been neglected to simplify analysis.

A summary of the worst-case errors over a 100°C temperature range is shown in Table 2 and discussed below. Note that the amplifier and comparator are very accurate and the accuracy of most systems is limited by external components.

**Input Offset Voltage:** The input offset voltage of the amplifier appears as an error in the voltage across  $R_{IN}$ . The resulting system error for a 100mV max  $V_{SENSE}$  is:

$$\frac{450\mu\text{V}}{100\text{mV}} = 0.45\%$$

**Input Bias Current:** The input bias current of the amplifier subtracts from the current being fed from  $R_{IN}$  to the output FET. The resulting error is:

$$350\text{nA} \cdot \frac{100\Omega}{100\text{mV}} = 0.035\%$$

$I_{B^+}$  is neglected since it produces very small voltage across  $R_{SENSE}$ .

**Gain Error:** The gain error of the internal amplifier is a measure of how accurately the sense voltage is forced across  $R_{IN}$ . Since this is specified as a percentage the resulting error is 0.2%

APPLICATIONS INFORMATION

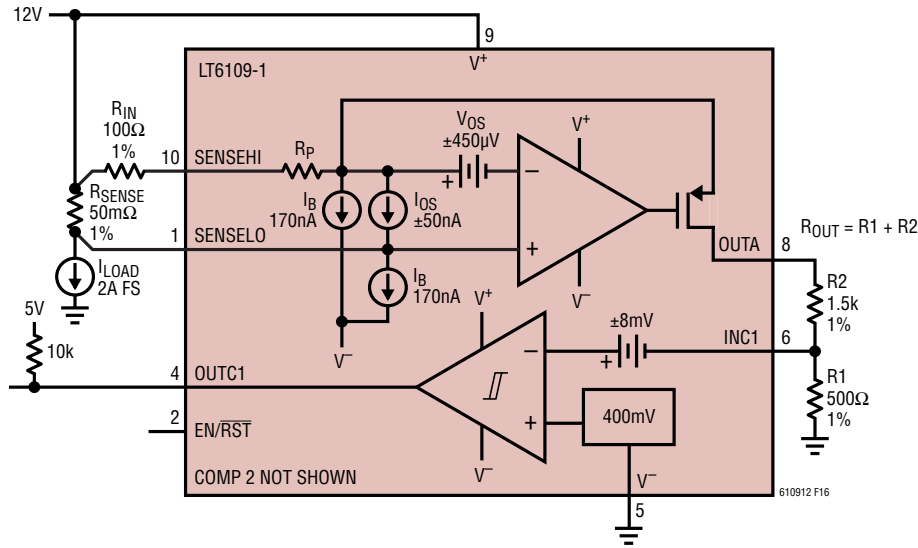

Figure 17. LT6109-1 Error Budget Configuration

Note that since the amplifier gain error is specified with an  $R_{IN} = 100\Omega$  it can be represented as a series resistance,  $R_P$ , with value  $200m\Omega$ . Using a larger value of  $R_{IN}$  can reduce the gain error since  $R_P$  will be less as a percentage as shown in Figure 6.

Supply Rejection: The amplifier supply rejection is a measure of how the input offset voltage changes with a change in supply and input common mode voltage. With 114dB, a 10V supply that varies by  $\pm 10\%$  will cause the following error:

$$\frac{2\mu V}{V} \cdot 1.2V = 0.0024\%$$

Common Mode Rejection: The amplifier common mode rejection is a measure of how the input offset voltage changes as the SENSEHI and SENSELO pins move common mode. If the inputs are tied to  $V^+$  then this error does not need to be considered because of the way PSRR is specified (see Note 7). With 103dB, the resulting change in offset voltage due to a  $\pm 10\%$  variation in a 12V battery connected to SENSEHI, SENSELO voltage creates the following error:

$$\frac{7\mu V}{V} \cdot 1.2V = 0.0084\%$$

Accuracy of External Gain Set Resistors: The gain is set by external resistors  $R_{IN}$  and  $R_{OUT}$ . The precision of these external resistors contributes directly to the system error. Using 0.1% resistors results in the following error:

$$2 \cdot 0.1\% = 0.2\%$$

Drift of Gain Set Resistors: The drift of the external gain set resistors also contributes directly to the system error. Using resistors with a maximum drift specification of 50ppm/°C results in the following error:

$$2 \cdot 50 \frac{\text{ppm}}{^\circ\text{C}} \cdot 100^\circ\text{C} = 1\%$$

Threshold Accuracy: The total error of the comparators and reference result in the following error:

$$\frac{8mV}{400mV} = 2\%$$

Accuracy of External Resistors: The comparator trip point is set by external resistors  $R_1$  and  $R_{IN}$ . The precision of these external resistors contribute directly to the system error. Using 0.1% resistors results in the following error:

$$2 \cdot 0.1\% = 0.2\%$$

## APPLICATIONS INFORMATION

Drift of External Resistors: The drift of R1 and R<sub>IN</sub> also affects the accuracy of the trip point. Using resistors with a drift of 50ppm/°C results in the following error:

$$2 \cdot 50 \frac{\text{ppm}}{^{\circ}\text{C}} \cdot 100^{\circ}\text{C} = 1\%$$

Accuracy of External Sense Resistor: The load current is converted to the sense voltage by R<sub>SENSE</sub>. The tolerance of R<sub>SENSE</sub> contributes directly to the system error. Using a 1% sense resistor results in a 1% error.

Drift of External Sense Resistor: The drift of R<sub>SENSE</sub> also affects accuracy. Using a sense resistor with a drift of 50ppm/°C results in the following error:

$$50\text{ppm}/^{\circ}\text{C} \cdot 100^{\circ}\text{C} = 0.5\%$$

**Table 2. Error Budget (Worst Case Over Temperature)**

| ERROR SOURCE   | LT6109 CIRCUIT CALCULATION   | % ERROR    |
|--|--|------------|
| <b>Amplifier Accuracy</b>                                |  |            |
| Input Offset Voltage                                     | 450μV/100mV • 100  | 0.45       |
| Input Bias Current                                       | 350nA • 100Ω/100mV • 100   | 0.035      |
| Gain Error   | 0.20%  | 0.2        |
| Supply Rejection   | (2μV/V • 1.2V)/100mV • 100   | 0.002      |
| Common Mode Rejection                                    | (7μV/V • 1.2V)/100mV • 100   | 0.008      |
|  | <b>Total Amplifier Accuracy</b>  | <b>0.7</b> |
| Accuracy of R <sub>IN</sub> , R <sub>OUT</sub> Resistors | 2 • 0.1%   | 0.2        |
| Drift of R <sub>IN</sub> , R <sub>OUT</sub> Resistors    | 2 • 50ppm/°C • 100°C • 100   | 1          |
| Accuracy of External Sense Resistor                      | 1 • 1%   | 1          |
| Drift of External Sense Resistor                         | 1 • 50ppm/°C • 100°C • 100   | 0.5        |
|  | <b>Total Amplifier Accuracy With External Resistors</b>                | <b>3.4</b> |
| <b>Comparator/Reference Accuracy</b>                     |  |            |
| Threshold Accuracy                                       | 2%   | 2          |
|  | <b>Total Comparator And Reference Accuracy</b>                         | <b>2</b>   |
| Accuracy of R <sub>IN</sub> , R <sub>OUT</sub> Resistors | 2 • 0.1%   | 0.2        |
| Drift of R <sub>IN</sub> , R <sub>OUT</sub> Resistors    | 2 • 50ppm/°C • 100°C • 100   | 1          |
| Accuracy of External Sense Resistor                      | 1 • 1%   | 1          |
| Drift of External Sense Resistor                         | 1 • 50ppm/°C • 100°C • 100   | 0.5        |
|  | <b>Total Comparator And Reference Accuracy with External Resistors</b> | <b>4.7</b> |

## TYPICAL APPLICATIONS

### Overcurrent and Undervoltage Battery Fault Protection

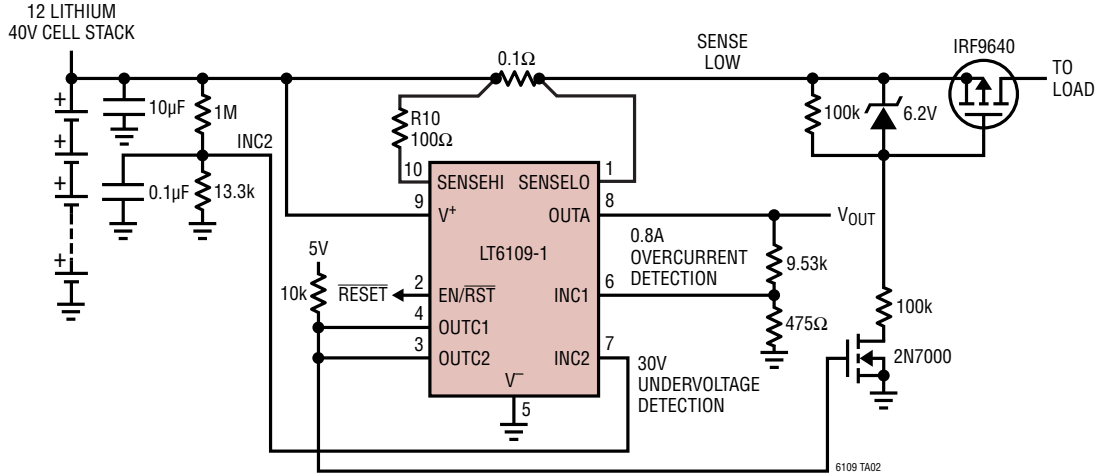

The comparators monitor for overcurrent and undervoltage conditions. If either fault condition is detected the battery will immediately be disconnected from the load.

The latching comparator outputs ensure the battery stays disconnected from the load until an outside source resets the LT6109 comparator outputs.

### MCU Interfacing with Hardware Interrupts

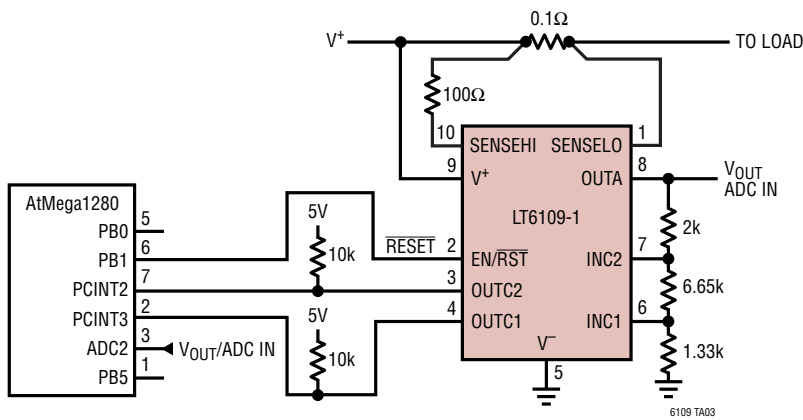

#### Example:

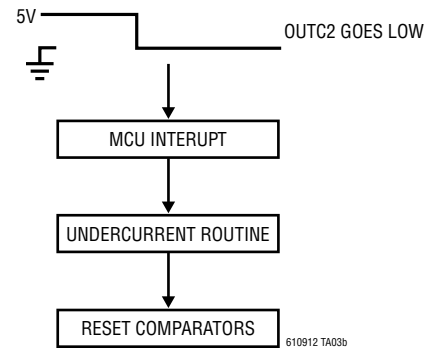

The comparators are set to have a 50mA undercurrent threshold and a 300mA overcurrent threshold. The MCU

will receive the comparator outputs as hardware interrupts and immediately run an appropriate fault routine.



# TYPICAL APPLICATIONS

## Simplified DC Motor Torque Control

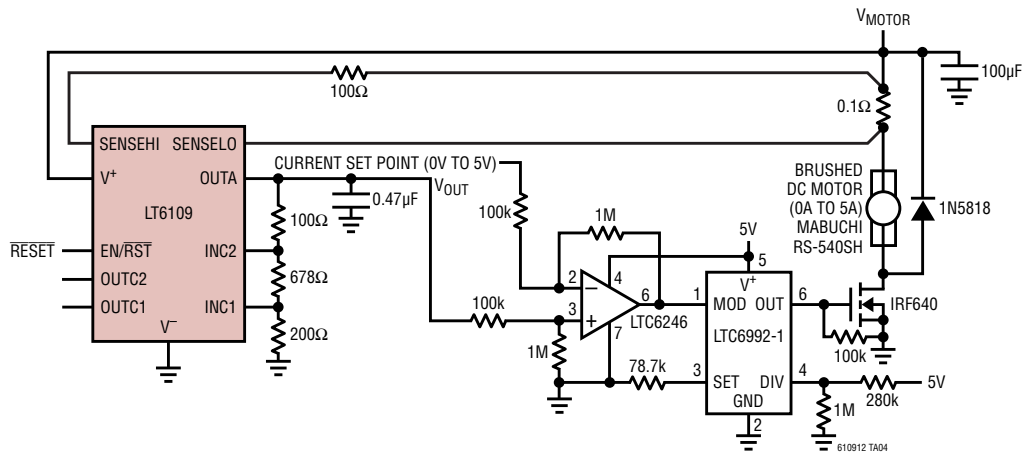

The figure shows a simplified DC motor control circuit. The circuit controls motor current, which is proportional to motor torque; the LT6109 is used to provide current

feedback to a difference amplifier that controls the current in the motor. The LTC<sup>®</sup>6992 is used to convert the output of the difference amp to the motors PWM control signal.

## Power-On Reset or Disconnect Using a TimerBlox<sup>®</sup> Circuit

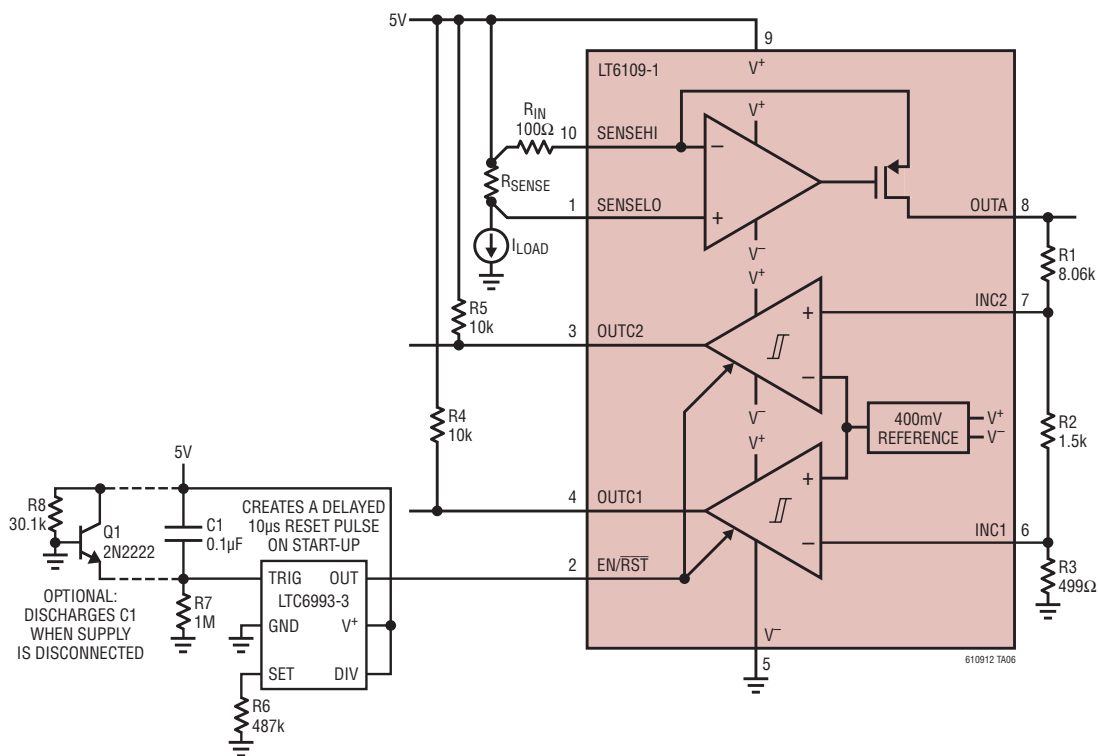

The LTC6993-1 provides a 10μs reset pulse to the LT6109-1. The reset pulse is delayed by R7 and C1 whose time constant must be greater than 10ms and longer than the supply turn-on time. Optional components R8 and Q1

discharge capacitor C1 if the supply and/or ground are disconnected. When power is restored C1 must recharge and the LT6109-1 is issued another reset pulse.



**PACKAGE DESCRIPTION**

**MS Package**  
**10-Lead Plastic MSOP**  
 (Reference LTC DWG # 05-08-1661 Rev E)

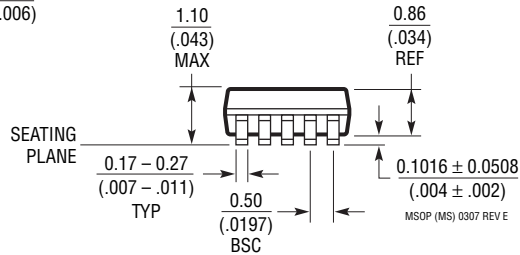
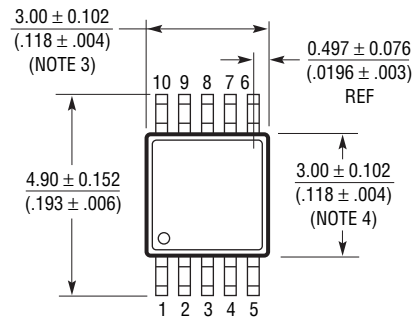
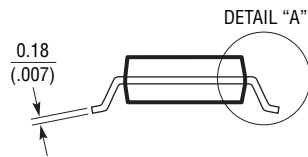
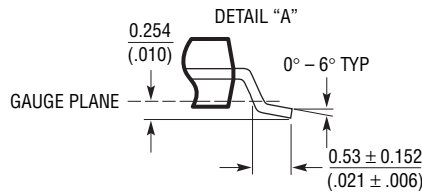
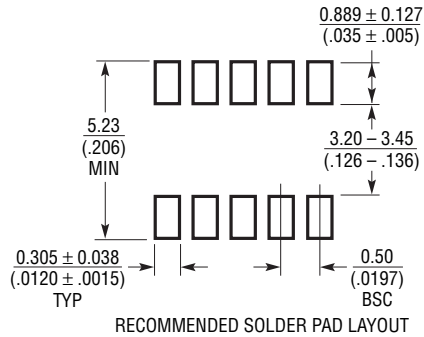

**NOTE:**

1. DIMENSIONS IN MILLIMETER/(INCH)
2. DRAWING NOT TO SCALE
3. DIMENSION DOES NOT INCLUDE MOLD FLASH, PROTRUSIONS OR GATE BURRS.  
 MOLD FLASH, PROTRUSIONS OR GATE BURRS SHALL NOT EXCEED 0.152mm (.006") PER SIDE
4. DIMENSION DOES NOT INCLUDE INTERLEAD FLASH OR PROTRUSIONS.  
 INTERLEAD FLASH OR PROTRUSIONS SHALL NOT EXCEED 0.152mm (.006") PER SIDE
5. LEAD COPLANARITY (BOTTOM OF LEADS AFTER FORMING) SHALL BE 0.102mm (.004") MAX

## TYPICAL APPLICATION

ADC Driving Application

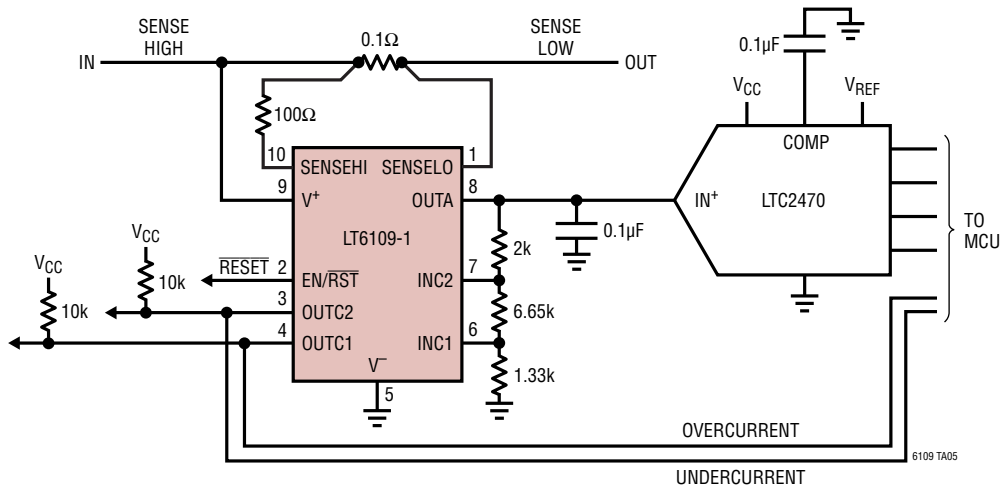

The low sampling current of the LTC2470 16-bit delta sigma ADC is ideal for the LT6109.

## RELATED PARTS

| PART NUMBER | DESCRIPTION  | COMMENTS  |
|-------------|--|---|
| LT1787      | Bidirectional High Side Current Sense Amplifier      | 2.7V to 60V, 75μV Offset, 60μA Quiescent, 8V/V Gain           |
| LTC4150     | Coulomb Counter/Battery Gas Gauge                    | Indicates Charge Quantity and Polarity                        |
| LT6100      | Gain-Selectable High Side Current Sense Amplifier    | 4.1V to 48V, Gain Settings: 10, 12.5, 20, 25, 40, 50V/V       |
| LTC6101     | High Voltage High Side Current Sense Amplifier       | Up to 100V, Resistor Set Gain, 300μV Offset, SOT-23           |
| LTC6102     | Zero Drift High Side Current Sense Amplifier         | Up to 100V, Resistor Set Gain, 10μV Offset, MSOP8/DFN         |
| LTC6103     | Dual High Side Current Sense Amplifier               | 4V to 60V, Resistor Set Gain, 2 Independent Amps, MSOP8       |
| LTC6104     | Bidirectional High Side Current Sense Amplifier      | 4V to 60V, Separate Gain Control for Each Direction, MSOP8    |
| LT6105      | Precision Rail-to-Rail Input Current Sense Amplifier | -0.3V to 44V Input Range, 300μV Offset, 1% Gain Error         |
| LT6106      | Low Cost High Side Current Sense Amplifier           | 2.7V to 36V, 250μV Offset, Resistor Set Gain, SOT-23          |
| LT6107      | High Temperature High Side Current Sense Amplifier   | 2.7V to 36V, -55°C to 150°C, Fully Tested: -55°C, 25°C, 150°C |
| LT6700      | Dual Comparator with 400mV Reference                 | 1.4V to 18V, 6.5μA Supply Current                             |