

## RX62T Group Renesas MCUs

R01DS0096EJ0100

Rev.1.00

Apr 20, 2011

100-MHz 32-bit RX MCUs, FPU, 165 DMIPS, 12-bit ADC (3 S/H circuits, double data register, amplifier, comparator): two units, 10-bit ADC one unit, the three ADC units are capable of simultaneous 7-ch. sampling, 100-MHz PWM (two three-phase complementary channels and four single-phase complementary channels or three three-phase complementary channels and one single-phase complementary channel)

## Features

### ■ 32-bit RX CPU core

- Max. operating frequency: 100 MHz  
Capable of 165 DMIPS in operation at 100 MHz
- Single precision 32-bit IEEE-754 floating point
- Accumulator handles 64-bit results (for a single instruction) from 32- × 32-bit operations
- Multiplication and division unit handles 32- × 32-bit operations (multiplication instructions take one CPU clock cycle)
- Fast interrupt
- Divider (fastest instruction execution takes two CPU clock cycles)
- Fast interrupt
- CISC Harvard architecture with 5-stage pipeline
- Variable-length instructions: Ultra-compact code
- Background JTAG debugging plus high-speed tracing

### ■ Operating voltage

- Single 3.3- or 5-V supply; 5-V analog supply is possible with 3.3-V products

### ■ Low-power design and architecture

- Four low-power modes

### ■ On-chip main flash memory, no wait states

- 100-MHz operation, 10-ns read cycle
- No wait states for reading at full CPU speed
- 64-Kbyte/128-Kbyte/256-Kbyte capacities
- For instructions and operands
- User code programmable via the SCI or JTAG

### ■ On-chip data flash memory

- Max. 32 Kbytes, reprogrammable up to 30,000 times
- Erasing and programming impose no load on the CPU.

### ■ On-chip SRAM, no wait states

- 8-Kbyte/16-Kbyte SRAM
- For instructions and operands

### ■ DMA

- DTC: The single unit is capable of transfer on multiple channels

### ■ Reset and supply management

- Power-on reset (POR)
- Low voltage detection (LVD) with voltage settings

### ■ Clock functions

- External crystal oscillator or internal PLL for operation at 8 to 12.5 MHz
- Internal 125-kHz LOCO for the IWDT
- Detection of main oscillator stoppage (for IEC 60730 compliance)

### ■ Independent watchdog timer (for IEC60730compliance)

- 125-kHz LOCO clock operation
- Software is incapable of stopping the robust WDT.

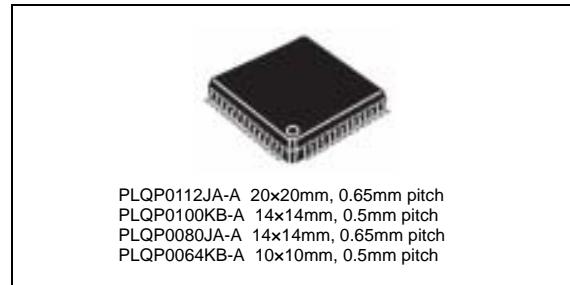

### ■ Up to 7 communications interfaces

- 1: CAN (compliant with ISO11898-1), incorporating 32 mailboxes
- 3: SCIs, with asynchronous mode (incorporating noise cancellation), clock-synchronous mode, and smart-card interface mode
- 1: I2C bus interface, capable of SMBus operation
- 1: RSPI
- 1: LIN

### ■ Up to 16 16-bit timers

- 8: 16-bit MTU3: 100-MHz operation, input capture, output compare, two three-phase complementary PWM output channels, complementary PWM imposing no load on the CPU, phase-counting mode
- 4: 16-bit GPT: 100-MHz operation, input capture, output compare, four complementary single-phase PWM output channels, or one three-phase complementary PWM output channel and one single-phase complementary PWM output channel, complementary PWM imposing no load on the CPU, operation linked with comparator (for counting and control of PWM-signal negation), detection of abnormal oscillation frequencies (for IEC 60730 compliance)
- 4: 16-bit CMT

### ■ Three A/D converter units for 1-MHz operation, for a total of 20 channels

- Three units are capable of simultaneous sampling on seven channels
- Self diagnosis (for IEC60730 compliance)
- 8: Two 12-bit ADC units: three sample-and-hold circuits, double data registers, amplifier, comparator
- 12: Single 10-bit ADC unit

### ■ CRC (cyclic redundancy check) calculation unit

- Monitoring of data being transferred (for IEC 60730 compliance)
- Monitoring of data in memory (for IEC 60730 compliance)

### ■ Up to 61 input-output ports and up to 21 input-only ports

- PORT registers: Monitoring of output ports (for IEC 60730 compliance)

### ■ Operating temp. range

- -40°C to +85°C

# 1. Overview

## 1.1 Outline of Specifications

Table 1.1 lists the specifications in outline, and Table 1.2 lists the functions of products.

**Table 1.1 Outline of Specifications (1 / 5)**

Classification	Module/Function	Description
CPU	CPU	<ul style="list-style-type: none"> <li>• Maximum operating frequency: 100MHz</li> <li>• 32-bit RX CPU</li> <li>• Minimum instruction execution time: One instruction per state (cycle of the system clock)</li> <li>• Address space: 4-Gbyte linear</li> <li>• Register set of the CPU</li> <li>• General purpose: Sixteen 32-bit registers</li> <li>• Control: Nine 32-bit registers</li> <li>• Accumulator: One 64-bit register</li> <li>• Basic instructions: 73</li> <li>• Floating-point instructions: 8</li> <li>• DSP instructions: 9</li> <li>• Addressing modes: 10</li> <li>• Data arrangement</li> <li>• Instructions: Little endian</li> <li>• Data: Selectable as little endian or big endian</li> <li>• On-chip 32-bit multiplier: 32 x 32 → 64 bits</li> <li>• On-chip divider: 32 / 32 → 32 bits</li> <li>• Barrel shifter: 32 bits</li> </ul>
	FPU	<ul style="list-style-type: none"> <li>• Single precision (32-bit) floating point</li> <li>• Data types and floating-point exceptions in conformance with the IEEE754 standard</li> </ul>
Memory	ROM	<ul style="list-style-type: none"> <li>• ROM capacity: 256 Kbytes (max.)</li> <li>• Two on-board programming modes</li> <li>• Boot mode (The user MAT is programmable via the SCI)</li> <li>• User program mode</li> <li>• Off-board programming</li> <li>• A PROM programmer can be used to program the user mat.</li> </ul>
	RAM	<ul style="list-style-type: none"> <li>• RAM capacity: 16 Kbytes (max.)</li> </ul>
	Data flash	<ul style="list-style-type: none"> <li>• Data flash capacity: 32 Kbytes (max.)</li> <li>• Supports background operations (BGO)</li> </ul>
MCU operating mode		<ul style="list-style-type: none"> <li>• Single-chip mode</li> </ul>
Clock	Clock generation circuit	<ul style="list-style-type: none"> <li>• One circuit: Main clock oscillator</li> <li>• Internal oscillator: Low-speed on-chip oscillator dedicated to IWDT</li> <li>• Structure of a PLL frequency synthesizer and frequency divider for selectable operating frequency</li> <li>• Oscillation stoppage detection</li> <li>• Independent frequency-division and multiplication settings for the system clock (ICLK) and peripheral module clock (PCLK)</li> <li>• The CPU and system sections such as other bus masters, MTU3, and GPT run in synchronization with the system clock (ICLK): 8 to 100 MHz.</li> <li>• Peripheral modules run in synchronization with the peripheral module clock (PCLK): 8 to 50 MHz</li> </ul>
Reset		Pin reset, power-on reset (automatic power-on reset when the power is turned on), voltage-monitoring reset, watchdog timer reset, independent watchdog timer reset, and deep software standby reset
Voltage detection circuit (LVD)		When the voltage on VCC falls below the voltage detection level (Vdet), an internal reset or internal interrupt is generated.
Low power consumption	Low power consumption facilities	<ul style="list-style-type: none"> <li>• Module stop function</li> <li>• Four low power consumption modes</li> <li>• Sleep mode, all-module clock stop mode, software standby mode, and deep software standby mode</li> </ul>

**Table 1.1 Outline of Specifications (2 / 5)**

Classification	Module/Function	Description
Interrupt	Interrupt control unit (ICU)	<ul style="list-style-type: none"> <li>Peripheral function interrupts: 101 sources</li> <li>External interrupts: 9 (NMI and IRQ0 to IRQ7 pins)</li> <li>Non-maskable interrupts: 3 (the NMI pin, oscillation stop detection interrupt, and voltage-monitoring interrupt)</li> <li>16 levels specifiable for the order of priority</li> </ul>
Data transfer	Data transfer controller (DTC)	<ul style="list-style-type: none"> <li>Three transfer modes: Normal transfer, repeat transfer, and block transfer</li> <li>Activation sources: Software trigger, external interrupts, and interrupt requests from peripheral functions</li> </ul>
I/O ports	Programmable I/O ports	<p>I/O port pins for devices in the 112-pin LQFP/100-pin LQFP/80-pin LQFP/64-pin LQFP</p> <ul style="list-style-type: none"> <li>I/O: 61/55/44/37</li> <li>Input only: 21/21/13/9</li> <li>Open-drain outputs: 2/2/2/2 (I<sup>2</sup>C bus interface pins)</li> <li>Large-current outputs: 12/12/6/6(0) (MTU3 and GPT pins) The 5-V version of the 64-pin product does not have large-current outputs.</li> <li>Reading out the states of pins is always possible.</li> </ul>
Timers	Multi-function timer pulse unit 3 (MTU3)	<ul style="list-style-type: none"> <li>16 bits x 8 channels</li> <li>Up to 24 pulse inputs/outputs and three pulse inputs</li> <li>Select from among six to eight counter-input clock signals for each channel (ICLK/1, ICLK/4, ICLK/16, ICLK/64, ICLK/256, ICLK/1024, MTCLKA, MTCLKB, MTCLKC, MTCLKD) other than channel 5, for which only four signals are available.</li> <li>24 output compare or input capture registers</li> <li>Counter clearing (clearing is synchronizable with compare match or input capture)</li> <li>Simultaneous writing to multiple timer counters (TCNT)</li> <li>Input to and output from all registers in synchronization with counter operation</li> <li>Buffered operation</li> <li>Cascade-connected operation</li> <li>38 kinds of interrupt source</li> <li>Automatic transfer of register data</li> <li>Pulse output modes Toggled, PWM, complementary PWM, and reset synchronous PWM</li> <li>Complementary PWM output mode Outputs non-overlapping waveforms for controlling 3-phase inverters Automatic specification of dead times PWM duty cycle: Selectable as any value from 0% to 100% Delay can be applied to requests for A/D conversion. Non-generation of interrupt requests at peak or trough values of counters can be selected. Double buffering</li> <li>Reset-synchronous PWM mode Three PWM waveforms and corresponding inverse waveforms are output with the desired duty cycles.</li> <li>Phase-counting mode</li> <li>Counter functionality for dead-time compensation</li> <li>Generation of triggers for A/D converters</li> <li>Differential timing for initiation of A/D conversion</li> </ul>
	Port output enable 3 (POE3)	<ul style="list-style-type: none"> <li>Control of the high-impedance state of the MTU3 and GPT's waveform output pins</li> <li>5 pins for input from signal sources: POE0, POE4, POE8, POE10, POE11</li> <li>Initiation on detection of short-circuited outputs (detection of simultaneous switching of large-current pins to the active level)</li> <li>Initiation by comparator-detection of analog level input to the 12-bit A/D converter</li> <li>Initiation by oscillation-stoppage detection</li> <li>Initiation by software</li> <li>Selection of which output pins should be placed in the high-impedance state at the time of each POE input or comparator detection</li> </ul>

**Table 1.1 Outline of Specifications (3 / 5)**

Classification	Module/Function	Description
Timers	General PWM timer (GPT)	<ul style="list-style-type: none"> <li>• 16 bits x 4 channels</li> <li>• Counting up or down (saw-wave), counting up and down (triangle-wave) selectable for all channels</li> <li>• Clock sources independently selectable for all channels</li> <li>• 2 input/output pins per channel</li> <li>• 2 output compare/input capture registers per channel</li> <li>• For the 2 output compare/input capture registers of each channel, 4 registers are provided as buffer registers and are capable of operating as comparison registers when buffering is not in use.</li> <li>• In output compare operation, buffer switching can be at peaks or troughs, enabling the generation of laterally asymmetrically PWM waveforms.</li> <li>• Registers for setting up frame intervals on each channel (with capability for generating interrupts on overflow or underflow)</li> <li>• Synchronizable operation of the several counters</li> <li>• Modes of synchronized operation (synchronized, or displaced by desired times for phase shifting)</li> <li>• Generation of dead times in PWM operation</li> <li>• Through combination of three counters, generation of automatic three-phase PWM waveforms incorporating dead times</li> <li>• Starting, clearing, and stopping counters in response to external or internal triggers</li> <li>• Internal trigger sources: output of the internal comparator detection, software, and compare-match</li> <li>• The frequency-divided system clock (ICLK) can be used as a counter clock for measuring timing of the edges of signals produced by frequency-dividing the low-speed on-chip oscillator clock signal dedicated to IWDT (to detect abnormal oscillation).</li> </ul>
	Compare match timer (CMT)	<ul style="list-style-type: none"> <li>• (16 bits x 2 channels) x 2 units</li> <li>• Select from among four internal clock signals (PCLK/8, PCLK/32, PCLK/128, PCLK/512)</li> </ul>
	Watchdog timer (WDT)	<ul style="list-style-type: none"> <li>• 8 bits x 1 channel</li> <li>• Select from among eight counter-input clock signals (PCLK/4, PCLK/64, PCLK/128, PCLK/512, PCLK/2048, PCLK/8192, PCLK/32768, PCLK/131072)</li> <li>• Switchable between watchdog timer mode and interval timer mode</li> </ul>
	Independent watchdog timer (IWDT)	<ul style="list-style-type: none"> <li>• 14 bits x 1 channel</li> <li>• Counter-input clock: low-speed on-chip oscillator dedicated to IWDT</li> </ul>
Communications	Serial communications interface (SCIb)	<ul style="list-style-type: none"> <li>• 3 channels</li> <li>• Serial communications modes: Asynchronous, clock synchronous, and smart-card interface</li> <li>• Multiprocessor communications</li> <li>• On-chip baud rate generator allows selection of the desired bit rate</li> <li>• Choice of LSB-first or MSB-first transfer</li> <li>• Noise cancellation (only available in asynchronous mode)</li> </ul>
	I <sup>2</sup> C bus interface (RIIC)	<ul style="list-style-type: none"> <li>• 1 channel</li> <li>• Communications formats: I<sup>2</sup>C bus format/SMBus format</li> <li>• Master/slave selectable</li> </ul>

**Table 1.1 Outline of Specifications (4 / 5)**

Classification	Module/Function	Description
Communications	CAN module (CAN) (as an optional function)	<ul style="list-style-type: none"> <li>• 1 channel</li> <li>• 32 mailboxes</li> </ul>
	Serial peripheral interface (RSPI)	<ul style="list-style-type: none"> <li>• 1 unit</li> <li>• RSPI transfer facility Using the MOSI (master out, slave in), MISO (master in, slave out), SSL (slave select), and RSPI clock (RSPCK) signals enables serial transfer through SPI operation (four lines) or clock-synchronous operation (three lines) Capable of handling serial transfer as a master or slave</li> <li>• Data formats Switching between MSB first and LSB first The number of bits in each transfer can be changed to any number of bits from 8 to 16, or to 20, 24, or 32 bits. 128-bit buffers for transmission and reception Up to four frames can be transmitted or received in a single transfer operation (with each frame having up to 32 bits)</li> <li>• Buffered structure</li> <li>• Double buffers for both transmission and reception</li> </ul>
	LIN module (LIN)	<ul style="list-style-type: none"> <li>• 1 channel (LIN master)</li> <li>• Supports revisions 1.3, 2.0, and 2.1 of the LIN protocol</li> </ul>
A/D converter	12-bit A/D converter (S12ADA)	<ul style="list-style-type: none"> <li>• 12 bits (2 units x 4 channels)</li> <li>• 12-bit resolution</li> <li>• Conversion time: 1.0 <math>\mu</math>s per channel (in operation with A/D conversion clock ADCLK at 50 MHz) for AVCC = 4.0 to 5.5 V 2.0 <math>\mu</math>s per channel (in operation with A/D conversion clock ADCLK at 25 MHz) for AVCC0 = 3.0 to 3.6 V</li> <li>• Two basic operating modes Single mode and scan mode</li> <li>• Scan mode One-cycle scan mode Continuous scan mode 2-channel scan mode (Input ports of the A/D unit are divided into two groups in this mode, and the activation sources are separately selectable for each group.)</li> <li>• Sample-and-hold function A common sample-and-hold circuit for both units is included. Additionally, sample-and-hold circuit for each unit is included. (three channels per unit)</li> <li>• A/D-conversion register settings for each input pin.</li> <li>• Two registers for the result of conversion are provided for a single analog input pin of each unit (AN000 and AN100).</li> <li>• Three ways to start A/D conversion Conversion can be started by software, a conversion start trigger from a timer (MTU3 or GPT), or an external trigger signal.</li> <li>• Functionality for 8- or 10-bit precision output Right-shifting of the results of conversion for output by two or four bits is selectable.</li> <li>• Self-diagnostic function The self-diagnostic function internally generates three analog input voltages (VREFL0, VREFH0 x 1/2, VREFH0).</li> <li>• Amplification of input signals by a programmable gain amplifier (three channels per unit) Amplification rate: 2.0-, 2.5-, 3.077-, 3.636-, 4.0-, 4.444-, 5.0-, 5.714-, 6.667-, 10.0-, or 13.333-times amplification (a total of 11 steps)</li> <li>• Window comparators (three channels per unit)</li> </ul>

**Table 1.1 Outline of Specifications (5 / 5)**

Classification	Module/Function	Description
A/D converter	10-bit A/D converter (ADA)	<ul style="list-style-type: none"> <li>• 10 bits (1 unit x 12 channels)</li> <li>• 10-bit resolution</li> <li>• Conversion time:               <ul style="list-style-type: none"> <li>1.0 <math>\mu</math>s per channel (in operation with A/D conversion clock ADCLK at 50 MHz) for AVCC0 = 4.0 to 5.5 V</li> <li>2.0 <math>\mu</math>s per channel (in operation with A/D conversion clock ADCLK at 25 MHz) for AVCC = 3.0 to 3.6 V</li> </ul> </li> <li>• Two basic operating modes               <ul style="list-style-type: none"> <li>Single mode and scan mode</li> </ul> </li> <li>• Scan mode               <ul style="list-style-type: none"> <li>One-cycle scan mode</li> <li>Continuous scan mode</li> </ul> </li> <li>• Sample-and-hold function               <ul style="list-style-type: none"> <li>A common sample-and-hold circuit for both units is included.</li> </ul> </li> <li>• A/D-conversion register settings for each input pin</li> <li>• Three ways to start A/D conversion               <ul style="list-style-type: none"> <li>Conversion can be started by software, a conversion start trigger from a timer (MTU3 or GPT), or an external trigger signal.</li> </ul> </li> <li>• Functionality for 8-bit precision output               <ul style="list-style-type: none"> <li>Right-shifting the results of conversion for output by two bits is selectable.</li> </ul> </li> <li>• Self-diagnostic function               <ul style="list-style-type: none"> <li>The self-diagnostic function internally generates three analog input voltages (AVSS, VREF x 1/2, VREF).</li> </ul> </li> </ul>
CRC calculator (CRC)		<ul style="list-style-type: none"> <li>• CRC code generation for arbitrary amounts of data in 8-bit units</li> <li>• Select any of three generating polynomials:               <ul style="list-style-type: none"> <li><math>X^8 + X^2 + X + 1</math>, <math>X^{16} + X^{15} + X^2 + 1</math>, or <math>X^{16} + X^{12} + X^5 + 1</math>.</li> </ul> </li> <li>• Generation of CRC codes for use with LSB-first or MSB-first communications is selectable.</li> </ul>
Operating frequency		ICLK: 8 to 100 MHz PCLK: 8 to 50 MHz
Power supply voltage		<ul style="list-style-type: none"> <li>• 3-V version               <ul style="list-style-type: none"> <li>VCC = PLLVCC = 2.7 to 3.6V</li> <li>AVCC0 = AVCC = 3.0 to 3.6V, or 4.0 to 5.5V</li> <li>VREFH0 = 3.0 to AVCC0, or 4.0 to AVCC0</li> <li>VREF = 3.0 to AVCC, or 4.0 to AVCC</li> </ul> </li> <li>• 5-V version               <ul style="list-style-type: none"> <li>VCC = PLLVCC = 4.0 to 5.5V</li> <li>AVCC0 = AVCC = 4.0 to 5.5V</li> <li>VREFH0 = 4.0 to AVCC0</li> <li>VREF = 4.0 to AVCC</li> </ul> </li> </ul>
Operating temperature		-40 to +85°C
Packages		112-pin LQFP (PLQP0112JA-A, 20x20-0.65-mm pitch) 100-pin LQFP (PLQP0100KB-A, 14x14-0.5-mm pitch) 80-pin LQFP (PLQP0080JA-A, 14x14-0.65-mm pitch) 64-pin LQFP (PLQP0064KB-A, 10x10-0.5-mm pitch)

**Table 1.2 Functions of RX62T Group Products**

Functions		RX62T Group			
		112 Pin	100 Pin	80 Pin	64 Pin
Data transfer	Data transfer controller (DTC)	○			
Interrupt control unit (ICU)	Input on the NMI pin	○			
	Input on the IRQ pins	○ (8)			○ (4)
Timers	Multi-function timer pulse unit 3 (MTU3)	○	○*		
	General PWM timer (GPT)	○	○*		
	Port output enable 3 (POE3)	○ (POE pins: 5)		○ (POE pins: 3)	
	Compare match timer (CMT)	○			
	Watchdog timer (WDT)	○			
	Independent watchdog timer (IWDT)	○			
Communication function	Serial communications interface (SCI)	○			
	I <sup>2</sup> C bus interface (RIIC)	○			
	CAN module (CAN) (as an optional function)	○			
	LIN module (LIN)	○			
	Serial peripheral interface (RSPI)	○			
12-bit A/D converter (S12ADA)		○ (4 ch. x 2 units)			
	Simultaneous sampling on three channels	○ (2 units)			
	Programmable gain amplifier	○ (3 ch. x 2 units)			
	Window comparator	○ (3 ch. x 2 units)			
10-bit A/D converter (ADA)	○ (12 ch.)		○ (4 ch.)	¾	
CRC calculator (CRC)	○				
I/O ports	I/O pins	61	55	44	37
	Input pins	21	21	13	9
Package		LQFP2020 (0.65-mm pitch)	LQFP1414 (0.5-mm pitch)	LQFP1414 (0.65-mm pitch)	LQFP1010 (0.5-mm pitch)

Note 1. ○: Supported, —: Not supported

Note 2. \* For the MTU and GPT, the number of pins will differ with the package. See the list of pins and pin functions for details.  
In addition, the CAN module is an optional function.

## 1.2 List of Products

Table 1.3 is a list of products, and Figure 1.1 shows how to read the product part no.

**Table 1.3 List of Products**

Group	Part No.	Package			Operating Frequency (Max.)	ROM Capacity	RAM Capacity	Data Flash	Operating Voltage		CAN
		Package Type	Pin Pitch	Package Code					VCC/ PLLVCC	AVCC/ AVCC0	
RX62T	R5F562TAADFH	LQFP2020-112	0.65 mm	PLQP0112JA-A	100 MHz	256 Kbytes	16 Kbytes	32K bytes	4.0 to 5.5 V	4.0 to 5.5 V	Supported
	R5F562TAADFP	LQFP1414-100	0.5 mm	PLQP0100KB-A							
	R5F562TAADFF	LQFP1414-80	0.65 mm	PLQP0080JA-A							
	R5F562TAADFM	LQFP1010-64	0.5 mm	PLQP0064KB-A							
	R5F562T7ADFH	LQFP2020-112	0.65 mm	PLQP0112JA-A							
	R5F562T7ADFP	LQFP1414-100	0.5 mm	PLQP0100KB-A							
	R5F562T7ADFF	LQFP1414-80	0.65 mm	PLQP0080JA-A							
	R5F562T7ADFM	LQFP1010-64	0.5 mm	PLQP0064KB-A							
	R5F562T6ADFH	LQFP1414-80	0.65 mm	PLQP0080JA-A							
	R5F562T6ADFM	LQFP1010-64	0.5 mm	PLQP0064KB-A							
	R5F562TABDFH	LQFP2020-112	0.65 mm	PLQP0112JA-A							
	R5F562TABDFP	LQFP1414-100	0.5 mm	PLQP0100KB-A							
	R5F562TABDFF	LQFP1414-80	0.65 mm	PLQP0080JA-A							
	R5F562TABDFM	LQFP1010-64	0.5 mm	PLQP0064KB-A							
	R5F562T7BDFH	LQFP2020-112	0.65 mm	PLQP0112JA-A							
	R5F562T7BDFP	LQFP1414-100	0.5 mm	PLQP0100KB-A							
	R5F562T7BDFF	LQFP1414-80	0.65 mm	PLQP0080JA-A							
	R5F562T7BDFM	LQFP1010-64	0.5 mm	PLQP0064KB-A							
	R5F562T6BDFH	LQFP1414-80	0.65 mm	PLQP0080JA-A							
	R5F562T6BDFM	LQFP1010-64	0.5 mm	PLQP0064KB-A							
	R5F562TADDFH	LQFP2020-112	0.65 mm	PLQP0112JA-A							
	R5F562TADDFP	LQFP1414-100	0.5 mm	PLQP0100KB-A							
	R5F562TADDFM	LQFP1010-64	0.5 mm	PLQP0064KB-A							
	R5F562T7DDFH	LQFP2020-112	0.65 mm	PLQP0112JA-A							
	R5F562T7DDFP	LQFP1414-100	0.5 mm	PLQP0100KB-A							
	R5F562T7DDFF	LQFP1414-80	0.65 mm	PLQP0080JA-A							
	R5F562T7DDFM	LQFP1010-64	0.5 mm	PLQP0064KB-A							
	R5F562T6DDFH	LQFP1414-80	0.65 mm	PLQP0080JA-A							
	R5F562T6DDFM	LQFP1010-64	0.5 mm	PLQP0064KB-A							
	R5F562TAEDFH	LQFP2020-112	0.65 mm	PLQP0112JA-A							
	R5F562TAEDFP	LQFP1414-100	0.5 mm	PLQP0100KB-A							
	R5F562TAEDFF	LQFP1414-80	0.65 mm	PLQP0080JA-A							
R5F562TAEDFM	LQFP1010-64	0.5 mm	PLQP0064KB-A								
R5F562T7EDFH	LQFP2020-112	0.65 mm	PLQP0112JA-A								
R5F562T7EDFP	LQFP1414-100	0.5 mm	PLQP0100KB-A								
R5F562T7EDFF	LQFP1414-80	0.65 mm	PLQP0080JA-A								
R5F562T7EDFM	LQFP1010-64	0.5 mm	PLQP0064KB-A								
R5F562T6EDFH	LQFP1414-80	0.65 mm	PLQP0080JA-A								
R5F562T6EDFM	LQFP1010-64	0.5 mm	PLQP0064KB-A								



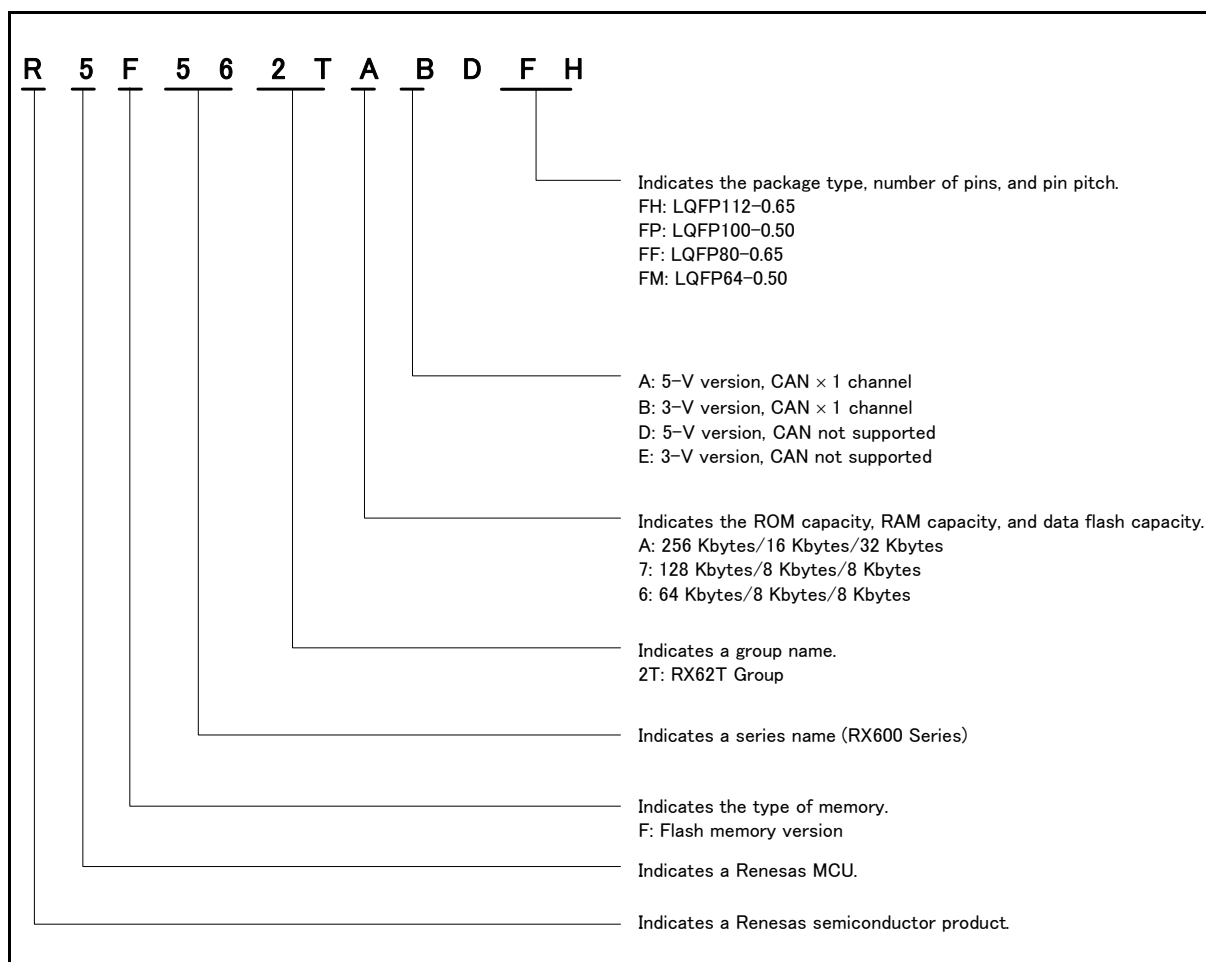

**Figure 1.1 How to Read the Product Part No.**

1.3 Block Diagram

Figure 1.2 shows a block diagram.

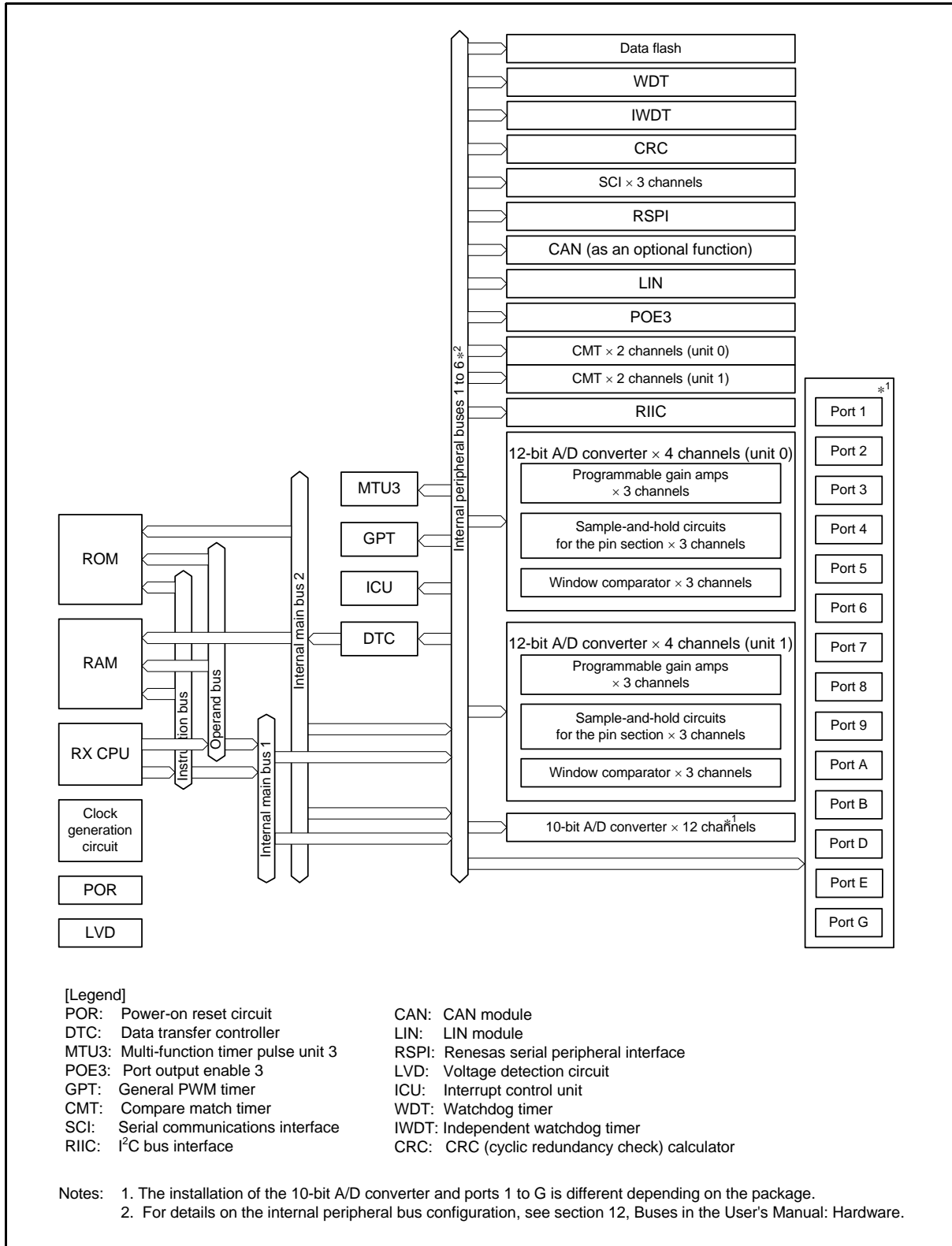

Figure 1.2 Block Diagram

### 1.4 Pin Assignments

Figure 1.3 to Figure 1.6 show the pins assignments. Table 1.4 to Table 1.7 show the list of pins and pin functions.

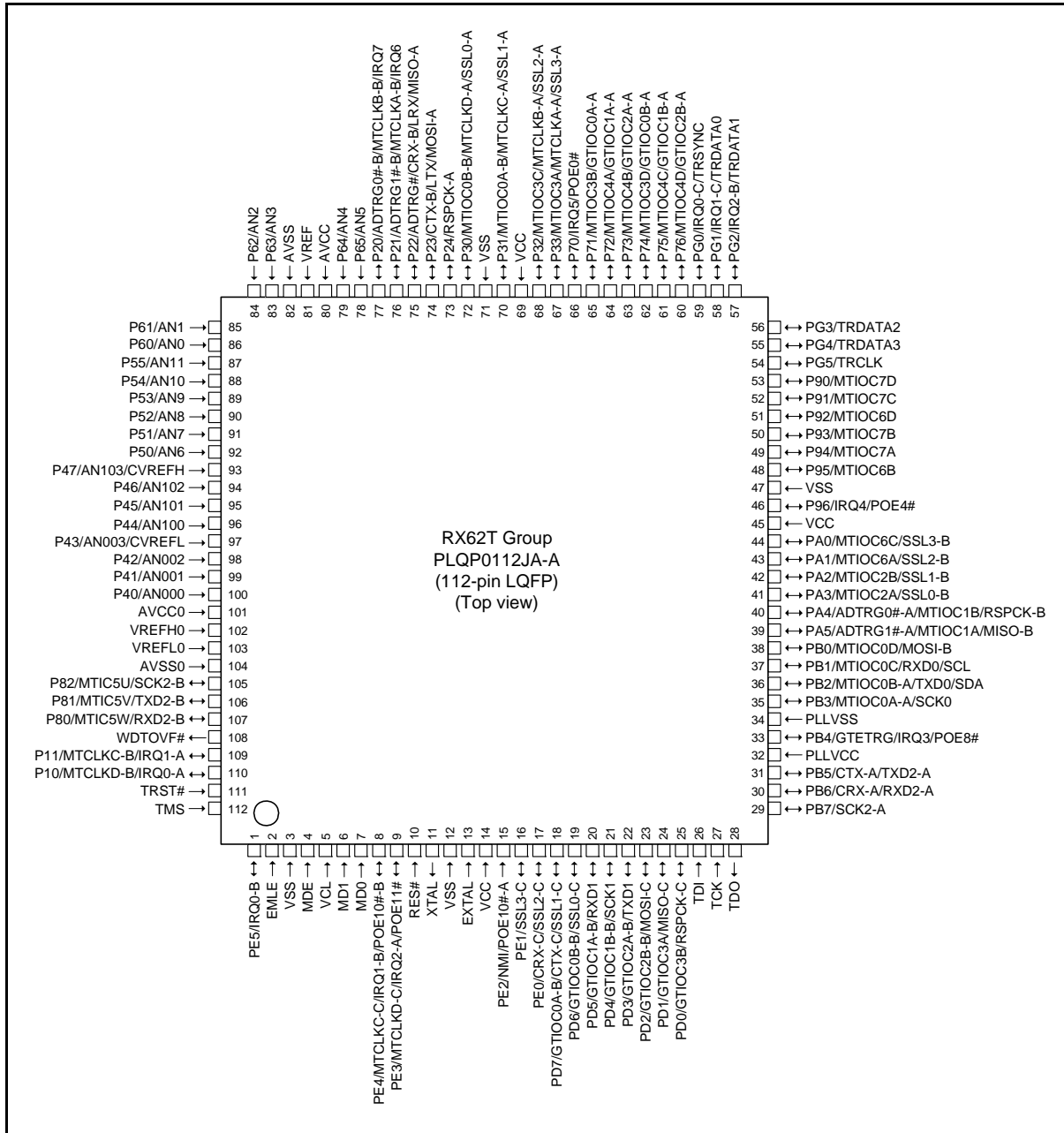

Figure 1.3 Pin Assignment of the 112-Pin LQFP

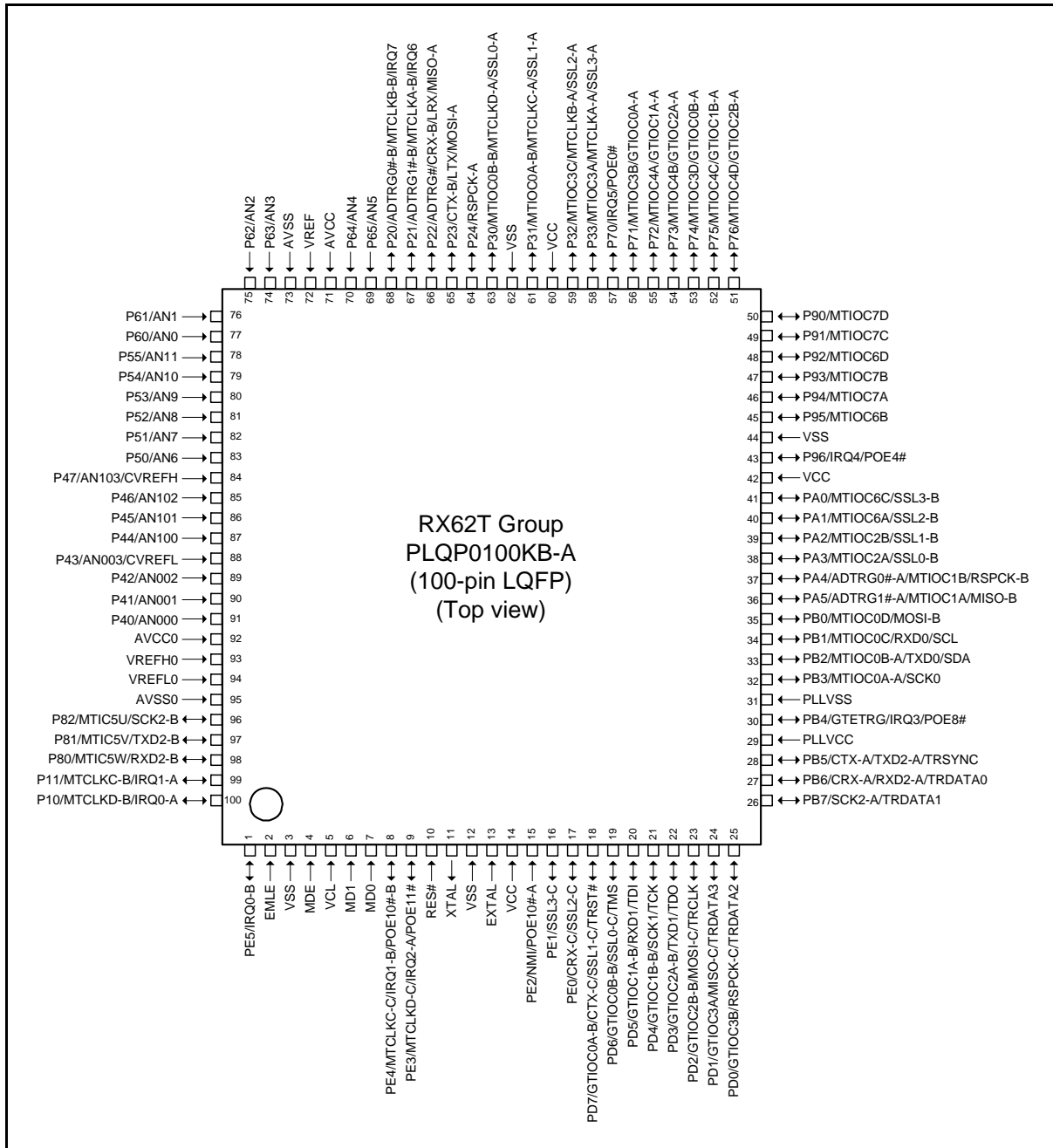

Figure 1.4 Pin Assignment of the 100-Pin LQFP

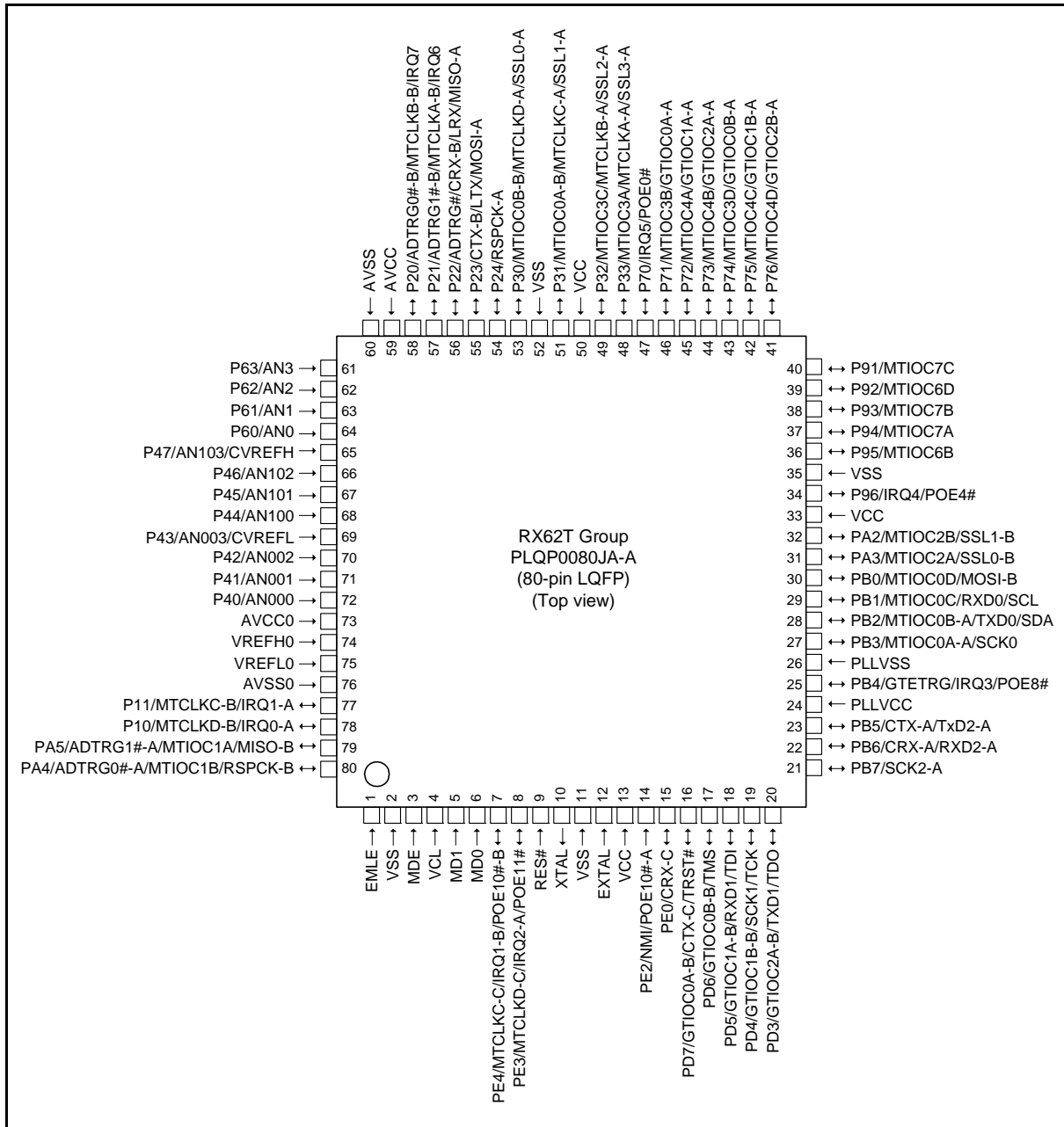

Figure 1.5 Pin Assignment of the 80-Pin LQFP

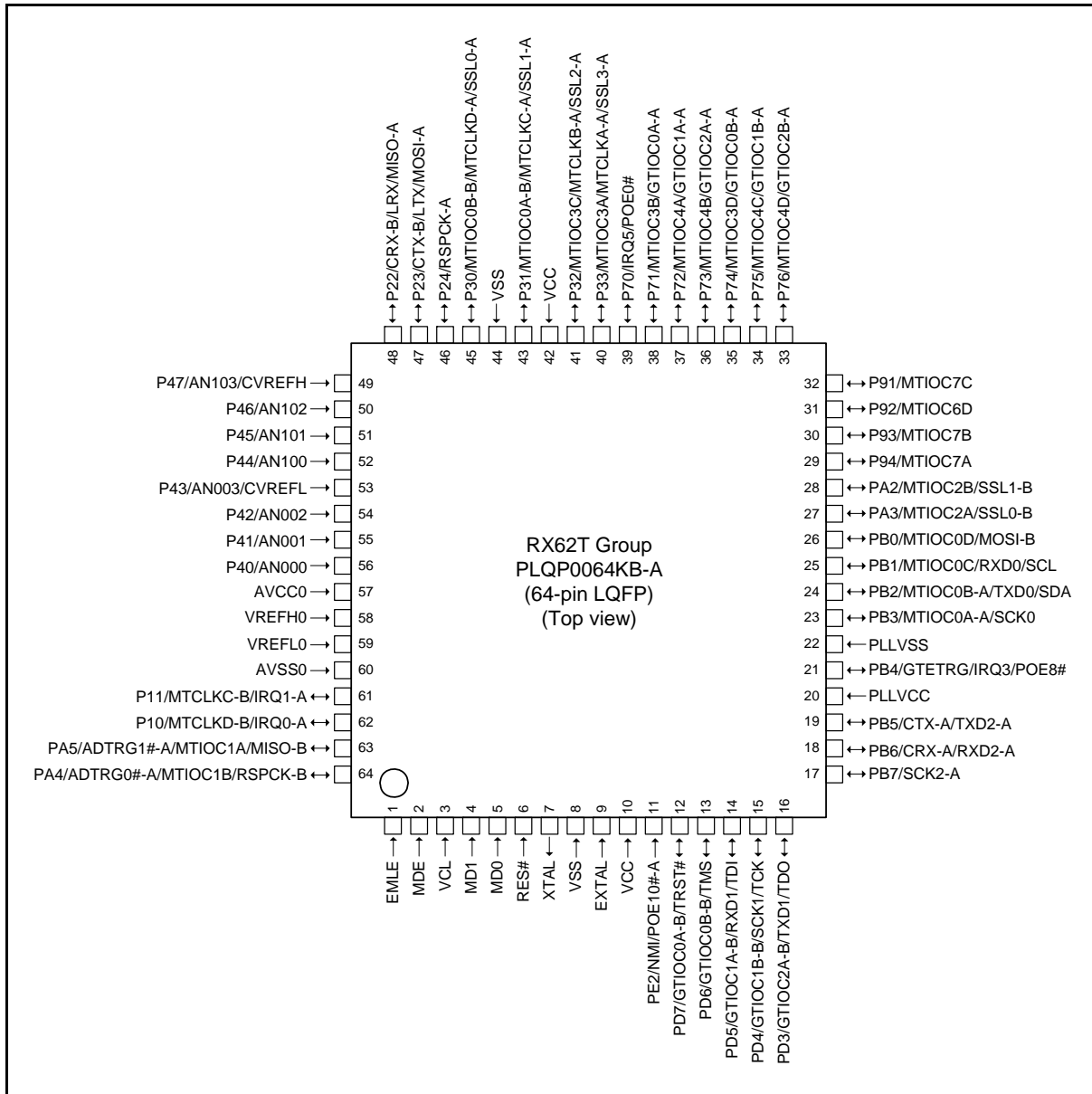

Figure 1.6 Pin Assignment of the 64-Pin LQFP

**Table 1.4 List of Pins and Pin Functions (112-Pin LQFP) (1 / 3)**

Pin No. (112-Pin LQFP)	Power Supply		I/O Port	Analog	Timer	Communi- cation	Interrupt	POE	Debugging
	Clock	System Control							
1			PE5				IRQ0-B		
2	EMLE								
3	VSS								
4	MDE								
5	VCL								
6	MD1								
7	MD0								
8			PE4		MTCLKC-C		IRQ1-B	POE10#-B	
9			PE3		MTCLKD-C		IRQ2-A	POE11#	
10	RES#								
11	XTAL								
12	VSS								
13	EXTAL								
14	VCC								
15			PE2				NMI	POE10#-A	
16			PE1			SSL3-C			
17			PE0			CRX-C/ SSL2-C			
18			PD7		GTIOC0A-B	CTX-C/ SSL1-C			
19			PD6		GTIOC0B-B	SSL0-C			
20			PD5		GTIOC1A-B	RXD1			
21			PD4		GTIOC1B-B	SCK1			
22			PD3		GTIOC2A-B	TXD1			
23			PD2		GTIOC2B-B	MOSI-C			
24			PD1		GTIOC3A	MISO-C			
25			PD0		GTIOC3B	RSPCK-C			
26									TDI
27									TCK
28									TDO
29			PB7			SCK2-A			
30			PB6			CRX-A/ RXD2-A			
31			PB5			CTX-A/ TXD2-A			
32	PLLVCC								
33			PB4		GTETRGR		IRQ3	POE8#	
34	PLLVSS								
35			PB3		MTIOC0A-A	SCK0			
36			PB2		MTIOC0B-A	TXD0/SDA			
37			PB1		MTIOC0C	RXD0/SCL			
38			PB0		MTIOC0D	MOSI-B			
39			PA5	ADTRG1#-A	MTIOC1A	MISO-B			
40			PA4	ADTRG0#-A	MTIOC1B	RSPCK-B			
41			PA3		MTIOC2A	SSL0-B			
42			PA2		MTIOC2B	SSL1-B			
43			PA1		MTIOC6A	SSL2-B			

Table 1.4 List of Pins and Pin Functions (112-Pin LQFP) (2 / 3)

Pin No. (112-Pin LQFP)	Power Supply		I/O Port	Analog	Timer	Communi- cation	Interrupt	POE	Debugging
	Clock	System Control							
44			PA0		MTIOC6C	SSL3-B			
45	VCC								
46			P96				IRQ4	POE4#	
47	VSS								
48			P95		MTIOC6B				
49			P94		MTIOC7A				
50			P93		MTIOC7B				
51			P92		MTIOC6D				
52			P91		MTIOC7C				
53			P90		MTIOC7D				
54			PG5						TRCLK
55			PG4						TRDATA3
56			PG3						TRDATA2
57			PG2				IRQ2-B		TRDATA1
58			PG1				IRQ1-C		TRDATA0
59			PG0				IRQ0-C		TRSYNC
60			P76		MTIOC4D/ GTIOC2B-A				
61			P75		MTIOC4C/ GTIOC1B-A				
62			P74		MTIOC3D/ GTIOC0B-A				
63			P73		MTIOC4B/ GTIOC2A-A				
64			P72		MTIOC4A/ GTIOC1A-A				
65			P71		MTIOC3B/ GTIOC0A-A				
66			P70				IRQ5	POE0#	
67			P33		MTIOC3A/ MTCLKA-A	SSL3-A			
68			P32		MTIOC3C/ MTCLKB-A	SSL2-A			
69	VCC								
70			P31		MTIOC0A-B/ MTCLKC-A	SSL1-A			
71	VSS								
72			P30		MTIOC0B-B/ MTCLKD-A	SSL0-A			
73			P24			RSPCK-A			
74			P23			CTX-B/ LTX/ MOSI-A			
75			P22	ADTRG#		CRX-B/ LRX/ MISO-A			
76			P21	ADTRG1#-B	MTCLKA-B		IRQ6		
77			P20	ADTRG0#-B	MTCLKB-B		IRQ7		
78			P65	AN5					
79			P64	AN4					



**Table 1.4 List of Pins and Pin Functions (112-Pin LQFP) (3 / 3)**

Pin No. (112-Pin LQFP)	Power Supply		I/O Port	Analog	Timer	Communi- cation	Interrupt	POE	Debugging
	Clock	System Control							
80	AVCC								
81	VREF								
82	AVSS								
83			P63	AN3					
84			P62	AN2					
85			P61	AN1					
86			P60	AN0					
87			P55	AN11					
88			P54	AN10					
89			P53	AN9					
90			P52	AN8					
91			P51	AN7					
92			P50	AN6					
93			P47	AN103/ CVREFH					
94			P46	AN102					
95			P45	AN101					
96			P44	AN100					
97			P43	AN003/ CVREFL					
98			P42	AN002					
99			P41	AN001					
100			P40	AN000					
101	AVCC0								
102	VREFH0								
103	VREFL0								
104	AVSS0								
105			P82		MTIC5U	SCK2-B			
106			P81		MTIC5V	TXD2-B			
107			P80		MTIC5W	RXD2-B			
108					WDTOVF#				
109			P11		MTCLKC-B		IRQ1-A		
110			P10		MTCLKD-B		IRQ0-A		
111									TRST#
112									TMS

**Table 1.5 List of Pins and Pin Functions (100-Pin LQFP) (1 / 3)**

Pin No. (80-Pin LQFP)	Power Supply		I/O Port	Analog	Timer	Communi- cation	Interrupt	POE	Debugging
	Clock	System Control							
1			PE5				IRQ0-B		
2	EMLE								
3	VSS								
4	MDE								
5	VCL								
6	MD1								
7	MD0								
8			PE4		MTCLKC-C		IRQ1-B	POE10#-B	
9			PE3		MTCLKD-C		IRQ2-A	POE11#	
10	RES#								
11	XTAL								
12	VSS								
13	EXTAL								
14	VCC								
15			PE2				NMI	POE10#-A	
16			PE1			SSL3-C			
17			PE0			CRX-C/ SSL2- C			
18			PD7		GTIOC0A-B	CTX-C/ SSL1-C			TRST#
19			PD6		GTIOC0B-B	SSL0-C			TMS
20			PD5		GTIOC1A-B	RXD1			TDI
21			PD4		GTIOC1B-B	SCK1			TCK
22			PD3		GTIOC2A-B	TXD1			TDO
23			PD2		GTIOC2B-B	MOSI-C			TRCLK
24			PD1		GTIOC3A	MISO-C			TRDATA3
25			PD0		GTIOC3B	RSPCK-C			TRDATA2
26			PB7			SCK2-A			TRDATA1
27			PB6			CRX-A/ RXD2- A			TRDATA0
28			PB5			CTX-A/ TXD2-A			TRSYNC
29	PLLVCC								
30			PB4		GTETRGR		IRQ3	POE8#	
31	PLLVSS								
32			PB3		MTIOC0A-A	SCK0			
33			PB2		MTIOC0B-A	TXD0/SDA			
34			PB1		MTIOC0C	RXD0/SCL			
35			PB0		MTIOC0D	MOSI-B			
36			PA5	ADTRG1#-A	MTIOC1A	MISO-B			
37			PA4	ADTRG0#-A	MTIOC1B	RSPCK-B			
38			PA3		MTIOC2A	SSL0-B			
39			PA2		MTIOC2B	SSL1-B			
40			PA1		MTIOC6A	SSL2-B			

**Table 1.5 List of Pins and Pin Functions (100-Pin LQFP) (2 / 3)**

Pin No. (80-Pin LQFP)	Power Supply Clock System Control	I/O Port	Analog	Timer	Communi- cation	Interrupt	POE	Debugging
41		PA0		MTIOC6C	SSL3-B			
42	VCC							
43		P96				IRQ4	POE4#	
44	VSS							
45		P95		MTIOC6B				
46		P94		MTIOC7A				
47		P93		MTIOC7B				
48		P92		MTIOC6D				
49		P91		MTIOC7C				
50		P90		MTIOC7D				
51		P76		MTIOC4D/ GTIOC2B-A				
52		P75		MTIOC4C/ GTIOC1B-A				
53		P74		MTIOC3D/ GTIOC0B-A				
54		P73		MTIOC4B/ GTIOC2A-A				
55		P72		MTIOC4A/ GTIOC1A-A				
56		P71		MTIOC3B/ GTIOC0A-A				
57		P70				IRQ5	POE0#	
58		P33		MTIOC3A/ MTCLKA-A	SSL3-A			
59		P32		MTIOC3C/ MTCLKB-A	SSL2-A			
60	VCC							
61		P31		MTIOC0A-B/ MTCLKC-A	SSL1-A			
62	VSS							
63		P30		MTIOC0B-B/ MTCLKD-A	SSL0-A			
64		P24			RSPCK-A			
65		P23			CTX-B/ LTX/ MOSI-A			
66		P22	ADTRG#		CRX-B/ LRX/ MISO-A			
67		P21	ADTRG1#-B	MTCLKA-B		IRQ6		
68		P20	ADTRG0#-B	MTCLKB-B		IRQ7		
69		P65	AN5					
70		P64	AN4					
71	AVCC							
72	VREF							
73	AVSS							
74		P63	AN3					
75		P62	AN2					
76		P61	AN1					

**Table 1.5 List of Pins and Pin Functions (100-Pin LQFP) (3 / 3)**

Pin No. (80-Pin LQFP)	Power Supply Clock System Control	I/O Port	Analog	Timer	Communi- cation	Interrupt	POE	Debugging
77		P60	AN0					
78		P55	AN11					
79		P54	AN10					
80		P53	AN9					
81		P52	AN8					
82		P51	AN7					
83		P50	AN6					
84		P47	AN103/ CVREFH					
85		P46	AN102					
86		P45	AN101					
87		P44	AN100					
88		P43	AN003/ CVREFL					
89		P42	AN002					
90		P41	AN001					
91		P40	AN000					
92	AVCC0							
93	VREFH0							
94	VREFL0							
95	AVSS0							
96		P82		MTIC5U	SCK2-B			
97		P81		MTIC5V	TXD2-B			
98		P80		MTIC5W	RXD2-B			
99		P11		MTCLKC-B		IRQ1-A		
100		P10		MTCLKD-B		IRQ0-A		

**Table 1.6 List of Pins and Pin Functions (80-Pin LQFP) (1 / 3)**

Pin No. (80-Pin LQFP)	Power Supply Clock System Control	I/O Port	Analog	Timer	Communi- cation	Interrupt	POE	Debugging
1	EMLE							
2	VSS							
3	MDE							
4	VCL							
5	MD1							
6	MD0							
7		PE4		MTCLKC-C		IRQ1-B	POE10#-B	
8		PE3		MTCLKD-C		IRQ2-A	POE11#	
9	RES#							
10	XTAL							
11	VSS							
12	EXTAL							
13	VCC							
14		PE2				NMI	POE10#-A	
15		PE0			CRX-C			
16		PD7		GTIOC0A-B	CTX-C			TRST#
17		PD6		GTIOC0B-B				TMS
18		PD5		GTIOC1A-B	RXD1			TDI
19		PD4		GTIOC1B-B	SCK1			TCK
20		PD3		GTIOC2A-B	TXD1			TDO
21		PB7			SCK2-A			
22		PB6			CRX-A/ RXD2-A			
23		PB5			CTX-A/ TXD2-A			
24	PLLVCC							
25		PB4		GTETRQ		IRQ3	POE8#	
26	PLLVSS							
27		PB3		MTIOC0A-A	SCK0			
28		PB2		MTIOC0B-A	TXD0/SDA			
29		PB1		MTIOC0C	RXD0/SCL			
30		PB0		MTIOC0D	MOSI-B			
31		PA3		MTIOC2A	SSL0-B			
32		PA2		MTIOC2B	SSL1-B			
33	VCC							
34		P96				IRQ4	POE4#	
35	VSS							
36		P95		MTIOC6B				
37		P94		MTIOC7A				
38		P93		MTIOC7B				
39		P92		MTIOC6D				
40		P91		MTIOC7C				
41		P76		MTIOC4D/ GTIOC2B-A				

**Table 1.6 List of Pins and Pin Functions (80-Pin LQFP) (2 / 3)**

Pin No. (80-Pin LQFP)	Power Supply Clock System Control	I/O Port	Analog	Timer	Communi- cation	Interrupt	POE	Debugging
42		P75		MTIOC4C/ GTIOC1B-A				
43		P74		MTIOC3D/ GTIOC0B-A				
44		P73		MTIOC4B/ GTIOC2A-A				
45		P72		MTIOC4A/ GTIOC1A-A				
46		P71		MTIOC3B/ GTIOC0A-A				
47		P70				IRQ5	POE0#	
48		P33		MTIOC3A/ MTCLKA-A	SSL3-A			
49		P32		MTIOC3C/ MTCLKB-A	SSL2-A			
50	VCC							
51		P31		MTIOC0A-B/ MTCLKC-A	SSL1-A			
52	VSS							
53		P30		MTIOC0B-B/ MTCLKD-A	SSL0-A			
54		P24			RSPCK-A			
55		P23			CTX-B/ LTX/ MOSI-A			
56		P22	ADTRG#		CRX-B/ LRX/ MISO-A			
57		P21	ADTRG1#-B	MTCLKA-B		IRQ6		
58		P20	ADTRG0#-B	MTCLKB-B		IRQ7		
59	AVCC							
60	AVSS							
61		P63	AN3					
62		P62	AN2					
63		P61	AN1					
64		P60	AN0					
65		P47	AN103/ CVREFH					
66		P46	AN102					
67		P45	AN101					
68		P44	AN100					
69		P43	AN003/ CVREFL					
70		P42	AN002					
71		P41	AN001					
72		P40	AN000					
73	AVCC0							
74	VREFH0							
75	VREFL0							

**Table 1.6 List of Pins and Pin Functions (80-Pin LQFP) (3 / 3)**

Pin No. (80-Pin LQFP)	Power Supply Clock System Control	I/O Port	Analog	Timer	Communi- cation	Interrupt	POE	Debugging
76	AVSS0							
77		P11		MTCLKC-B		IRQ1-A		
78		P10		MTCLKD-B		IRQ0-A		
79		PA5	ADTRG1#-A	MTIOC1A	MISO-B			
80		PA4	ADTRG0#-A	MTIOC1B	RSPCK-B			

**Table 1.7 List of Pins and Pin Functions (64-Pin LQFP) (1 / 2)**

Pin No. (64-Pin LQFP)	Power Supply Clock System Control	I/O Port	Analog	Timer	Communi- cation	Interrupt	POE	Debuggi ng
1	EMLE							
2	MDE							
3	VCL							
4	MD1							
5	MD0							
6	RES#							
7	XTAL							
8	VSS							
9	EXTAL							
10	VCC							
11		PE2				NMI	POE10#-A	
12		PD7		GTIOC0A-B				TRST#
13		PD6		GTIOC0B-B				TMS
14		PD5		GTIOC1A-B	RXD1			TDI
15		PD4		GTIOC1B-B	SCK1			TCK
16		PD3		GTIOC2A-B	TXD1			TDO
17		PB7			SCK2-A			
18		PB6			CRX-A/RXD2-A			
19		PB5			CTX-A/ TXD2-A			
20	PLLVC							
21		PB4		GTETR		IRQ3	POE8#	
22	PLLVS							
23		PB3		MTIOC0A-A	SCK0			
24		PB2		MTIOC0B-A	TXD0/SDA			
25		PB1		MTIOC0C	RXD0/SCL			
26		PB0		MTIOC0D	MOSI-B			
27		PA3		MTIOC2A	SSL0-B			
28		PA2		MTIOC2B	SSL1-B			
29		P94		MTIOC7A				
30		P93		MTIOC7B				
31		P92		MTIOC6D				
32		P91		MTIOC7C				
33		P76		MTIOC4D/ GTIOC2B-A				
34		P75		MTIOC4C/ GTIOC1B-A				
35		P74		MTIOC3D/ GTIOC0B-A				
36		P73		MTIOC4B/ GTIOC2A-A				
37		P72		MTIOC4A/ GTIOC1A-A				
38		P71		MTIOC3B/ GTIOC0A-A				
39		P70				IRQ5	POE0#	



**Table 1.7 List of Pins and Pin Functions (64-Pin LQFP) (2 / 2)**

Pin No. (64-Pin LQFP)	Power Supply Clock System Control	I/O Port	Analog	Timer	Communi- cation	Interrupt	POE	Debuggi ng
40		P33		MTIOC3A/ MTCLKA-A	SSL3-A			
41		P32		MTIOC3C/ MTCLKB-A	SSL2-A			
42	VCC							
43		P31		MTIOC0A-B/ MTCLKC-A	SSL1-A			
44	VSS							
45		P30		MTIOC0B-B/ MTCLKD-A	SSL0-A			
46		P24			RSPCK-A			
47		P23			CTX-B/ LTX/ MOSI-A			
48		P22			CRX-B/ LRX/ MISO-A			
49		P47	AN103/ CVREFH					
50		P46	AN102					
51		P45	AN101					
52		P44	AN100					
53		P43	AN003/ CVREFL					
54		P42	AN002					
55		P41	AN001					
56		P40	AN000					
57	AVCC0							
58	VREFH0							
59	VREFL0							
60	AVSS0							
61		P11		MTCLKC-B		IRQ1-A		
62		P10		MTCLKD-B		IRQ0-A		
63		PA5	ADTRG1#-A	MTIOC1A	MISO-B			
64		PA4	ADTRG0#-A	MTIOC1B	RSPCK-B			

## 1.5 Pin Functions

Table 1.8 lists the pin functions.

**Table 1.8 Pin Functions (1 / 4)**

Classifications	Pin Name	I/O	Description
Power supply	VCC	Input	Power supply pin. Connect it to the system power supply.
	VCL	Input	Connect this pin to VSS via a 0.1- $\mu$ F capacitor. The capacitor should be placed close to the pin.
	VSS	Input	Ground pin. Connect it to the system power supply (0 V).
	PLLVCC	Input	Power supply pin for the PLL circuit. Connect it to the system power supply.
	PLLVSS	Input	Ground pin for the PLL circuit.
Clock	XTAL	Output	Pins for a crystal resonator. An external clock signal can be input through the EXTAL pin.
	EXTAL	Input	
Operating mode control	MD0 MD1 MDE	Input	Pins for setting the operating mode. The signal levels on these pins must not be changed during operation.
System control	RES#	Input	Reset signal input pin. This LSI enters the reset state when this signal goes low.
	EMLE	Input	Input pin for the on-chip emulator enable signal. When the on-chip emulator is used, this pin should be driven high. When not used, it should be driven low.
On-chip emulator	TRST#	Input	On-chip emulator pins. When the EMLE pin is driven high, these pins are dedicated for the on-chip emulator.
	TMS	Input	
	TDI	Input	
	TCK	Input	
	TDO	Output	
	TRCLK	Output	This pin outputs the clock for synchronization with the trace data. Not included in the 80-/64-pin versions.
	TRSYNC	Output	This pin indicates that output from the TRDATA0 to TRDATA3 pins is valid. Not included in the 80-/64-pin versions.
TRDATA0 to TRDATA3	Output	These pins output the trace information. Not included in the 80-/64-pin versions.	
Interrupt (ICU)	NMI	Input	Non-maskable interrupt request signal.
	IRQ0-A/IRQ0-B/IRQ0-C IRQ1-A/IRQ1-B/IRQ1-C IRQ2-A/IRQ2-B IRQ3 to IRQ7	Input	Interrupt request signals. The IRQ0-C/IRQ1-C/IRQ2-B pin is not included in the 100-pin version. The IRQ0-B/IRQ0-C/IRQ1-C/IRQ2-B pin is not included in the 80-pin version. The IRQ0-B/IRQ0-C/IRQ1-B/IRQ1-/IRQ2-A/IRQ2-B/IRQ4/IRQ6/IRQ7 pin is not included in the 64-pin version.

**Table 1.8 Pin Functions (2 / 4)**

Classifications	Pin Name	I/O	Description
Multi-function timer pulse unit 3 (MTU3)	MTIOC0A-A/MTIOC0A-B MTIOC0B-A/MTIOC0B-B MTIOC0C, MTIOC0D	I/O	The MTU0.TGRA to MTU0.TGRD input capture input/output compare output/PWM output pins.
	MTIOC1A, MTIOC1B	I/O	The MTU1.TGRA and MTU1.TGRB input capture input/output compare output/PWM output pins.
	MTIOC2A, MTIOC2B	I/O	The MTU2.TGRA and MTU2.TGRB input capture input/output compare output/PWM output pins.
	MTIOC3A, MTIOC3B MTIOC3C, MTIOC3D	I/O	The MTU3.TGRA and MTU3.TGRD input capture input/output compare output/PWM output pins. Pins MTIOC3B and MTIOC3D can be used for large-current output.
	MTIOC4A, MTIOC4B MTIOC4C, MTIOC4D	I/O	The MTU4.TGRA and MTU4.TGRD input capture input/output compare output/PWM output pins. These pins can be used for large-current output.
	MTIC5U, MTIC5V, MTIC5W	Input	The MTU5.TGRU, MTU5.TGRV, and MTU5.TGRW input capture input/dead time compensation input pins. Not included in the 80-/64-pin versions.
	MTIOC6A, MTIOC6B MTIOC6C, MTIOC6D	I/O	The MTU6.TGRA to MTU6.TGRD input capture input/output compare output/PWM output pins. Pins MTIOC6B and MTIOC6D can be used for large-current output. The MTIOC6A/MTIOC6C pin is not included in the 80-pin version. The MTIOC6A/MTIOC6B/MTIOC6C pin is not included in the 64-pin version.
	MTIOC7A, MTIOC7B MTIOC7C, MTIOC7D	I/O	The MTU7.TGRA to MTU7.TGRD input capture input/output compare output/PWM output pins. These pins can be used for large-current output. The MTIOC7D pin is not included in the 80-/64-pin versions.
	MTCLKA-A/MTCLKA-B MTCLKB-A/MTCLKB-B MTCLKC-A/MTCLKC-B/ MTCLKC-C MTCLKD-A/MTCLKD-B/ MTCLKD-C	Input	Input pins for external clock signals. The MTCLKA-B/MTCLKB-B/MTCLKC-C/MTCLKD-C pin is not included in the 64-pin version.
General PWM timer (GPT)	GTIOC0A-A/GTIOC0A-B GTIOC0B-A/GTIOC0B-B	I/O	The GPT0.GTCCRA and GPT0.GTCCRB CCRB input capture input/output compare output/PWM output pins. Pins GTIOC0A-A and GTIOC0B-A can be used for large-current output.
	GTIOC1A-A/GTIOC1A-B GTIOC1B-A/GTIOC1B-B	I/O	The GPT1.GTCCRA and GPT1.GTCCRB input capture input/output compare output/PWM output pins. Pins GTIOC1A-A and GTIOC1B-A can be used for large-current output.
	GTIOC2A-A/GTIOC2A-B GTIOC2B-A/GTIOC2B-B	I/O	The GPT2.GTCCRA and GPT2.GTCCRB input capture input/output compare output/PWM output pins. Pins GTIOC2A-A and GTIOC2B-A can be used for large-current output. The GTIOC2B-B pin is not included in the 80-pin version.
	GTIOC3A, GTIOC3B	I/O	The GPT3.GTCCRA and GPT3.GTCCRB input capture input/output compare output/PWM output pins. Not included in the 80-/64-pin versions.
	GTETRG	Input	External trigger input pin for the GPT
Port output enable 3 (POE3)	POE0#, POE4#, POE8# POE10#-A/POE10#-B POE11#	Input	Input pins for request signals to place the MTU3 and GPT large-current pins in the high impedance state. The POE4#/ POE10#-B/POE11# pin is not included in the 64-pin version.
Watchdog timer (WDT)	WDOVF#	Output	Output pin for the counter-overflow signal in watchdog-timer mode. Not included in the 100-/80-/64-pin versions.

**Table 1.8 Pin Functions (3 / 4)**

Classifications	Pin Name	I/O	Description
Serial communications interface (SCIb)	TXD0, TXD1?TXD2-A/TXD2-B	Output	Output pins for data transmission. The TXD2-B pin is not included in the 80-/64-pin versions.
	RXD0, RXD1, RXD2-A/RXD2-B	Input	Input pins for data reception. The RXD2-B pin is not included in the 80-/64-pin versions.
	SCK0, SCK1, SCK2-A/SCK2-B	I/O	Input/output pins for clock signals. The SCK2-B pin is not included in the 80-/64-pin versions.
I <sup>2</sup> C bus interface (RIIC)	SCL	I/O	Input/output pin for I <sup>2</sup> C bus interface clocks. Bus can be directly driven by the NMOS open drain output.
	SDA	I/O	Input/output pin for I <sup>2</sup> C bus interface data. Bus can be directly driven by the NMOS open drain output.
CAN module (CAN) (as an optional function)	CRX-A/CRX-B/CRX-C	Input	Input pin for the CAN. The CRX-C pin is not included in the 64-pin version.
	CTX-A/CTX-B/CTX-C	Output	Output pin for the CAN. The CTX-C pin is not included in the 64-pin version.
LIN module (LIN)	LRX	Input	Input pin for the LIN.
	LTX	Output	Output pin for the LIN.
Serial peripheral interface (RSPI)	RSPCK-A/RSPCK-B/RSPCK-C	I/O	Clock input/output pin for the RSPI. The RSPCK-C pin is not included in the 80-/64-pin versions.
	MOSI-A/MOSI-B/MOSI-C	I/O	Inputs or outputs data output from the master for the RSPI. The MOSI-C pin is not included in the 80-/64-pin versions.
	MISO-A/MISO-B/MISO-C	I/O	Inputs or outputs data output from the slave for the RSPI. The MISO-C pin is not included in the 80-/64-pin versions.
	SSL0-A/SSL0-B/SSL0-C	I/O	Select the slave for the RSPI. The SSL0-C/SSL1-C/SSL2-C/SSL3-C pin is not included in the 80-/64-pin versions.
	SSL1-A/SSL1-B/SSL1-C SSL2-A/SSL2-B/SSL2-C SSL3-A/SSL3-B/SSL3-C	Output	
A/D converter	AN000 to AN003 AN100 to AN103	Input	Input pins for the analog signals to be processed by the 12-bit A/D converter.
	AN0 to AN11	Input	Input pins for the analog signals to be processed by the 10-bit A/D converter. The AN4 to AN11 pins are not included in the 80-pin version. Not included in the 64-pin version.
	ADTRG0#-A/ADTRG0#-B ADTRG1#-A/ADTRG1#-B ADTRG#	Input	Input pins for the external trigger signals that start the A/D conversion. The ADTRG0#-B/ADTRG1#-B/ADTRG# pin is not included in the 64-pin version.
	CVREFH	Input	Input pin for the high-level reference voltage to the comparator
	CVREFL	Input	Input pin for the low-level reference voltage to the comparator
Analog power supply	AVCC0	Input	Analog power supply pin for the 12-bit A/D converter. When the A/D converter is not in use, connect this pin to the system power supply.
	AVSS0	Input	Ground pin for the 12-bit A/D converter. Connect this pin to the system power supply (0 V).
	VREFH0	Input	Reference power supply pin for the 12-bit A/D converter. When the 12-bit A/D converter is not in use, connect this pin to the system power supply.
	VREFL0	Input	Ground pin of the reference power supply pin for the 12-bit A/D converter. When the 12-bit A/D converter is not in use, connect this pin to the system power supply (0 V).
	AVCC	Input	Analog power supply pin for the 10-bit A/D converter. When the A/D converter is not in use, connect this pin to the system power supply. Not included in the 64-pin version.
	AVSS	Input	Ground pin for the 10-bit A/D converter. Connect this pin to the system power supply (0 V). Not included in the 64-pin version.
	VREF	Input	Reference power supply pin for the 10-bit A/D converter. When the 10-bit A/D converter is not in use, connect this pin to the system power supply. Not included in the 80-/64-pin versions.

**Table 1.8 Pin Functions (4 / 4)**

Classifications	Pin Name	I/O	Description
I/O ports	P10, P11	I/O	2-bit input/output pins.
	P20 to P24	I/O	5-bit input/output pins. The P20/P21 pin is not included in the 64-pin version.
	P30 to P33	I/O	4-bit input/output pins.
	P40 to P47	Input	8-bit input pins.
	P50 to P55	Input	6-bit input pins. Not included in the 80-/64-pin versions.
	P60 to P65	Input	6-bit input pins. The P64/P6 pin is not included in the 80-pin version. Not included in the 64-pin version.
	P70 to P76	I/O	7-bit input/output pins.
	P80 to P82	I/O	3-bit input/output pins. Not included in the 80-/64-pin versions.
	P90 to P96	I/O	7-bit input/output pins. The P90 pin is not included in the 80-pin version. The P90/P95/P96 pin is not included in the 64-pin version.
	PA0 to PA5	I/O	6-bit input/output pins. The PA0/PA1 pin is not included in the 80-/64-pin versions.
	PB0 to PB7	I/O	8-bit input/output pins.
	PD0 to PD7	I/O	8-bit input/output pins. The PD0/PD1/PD2 pin is not included in the 80-/64-pin versions.
	PE0, PE1, PE3 to PE5	I/O	5-bit input/output pins. The PE1/PE5 pin is not included in the 80-pin version. Not included in the 64-pin version.
	PE2	Input	1-bit input pin.
PG0 to PG5	I/O	6-bit input/output pins. Not included in the 100-/80-/64-pin versions.	

Note: • Which pins are and are not incorporated depends on the package.  
For details, see the list of pins and pin functions in Table 1.4 to Table 1.7.

## 2. CPU

The RX CPU has sixteen general-purpose registers, nine control registers, and one accumulator used for DSP instructions.

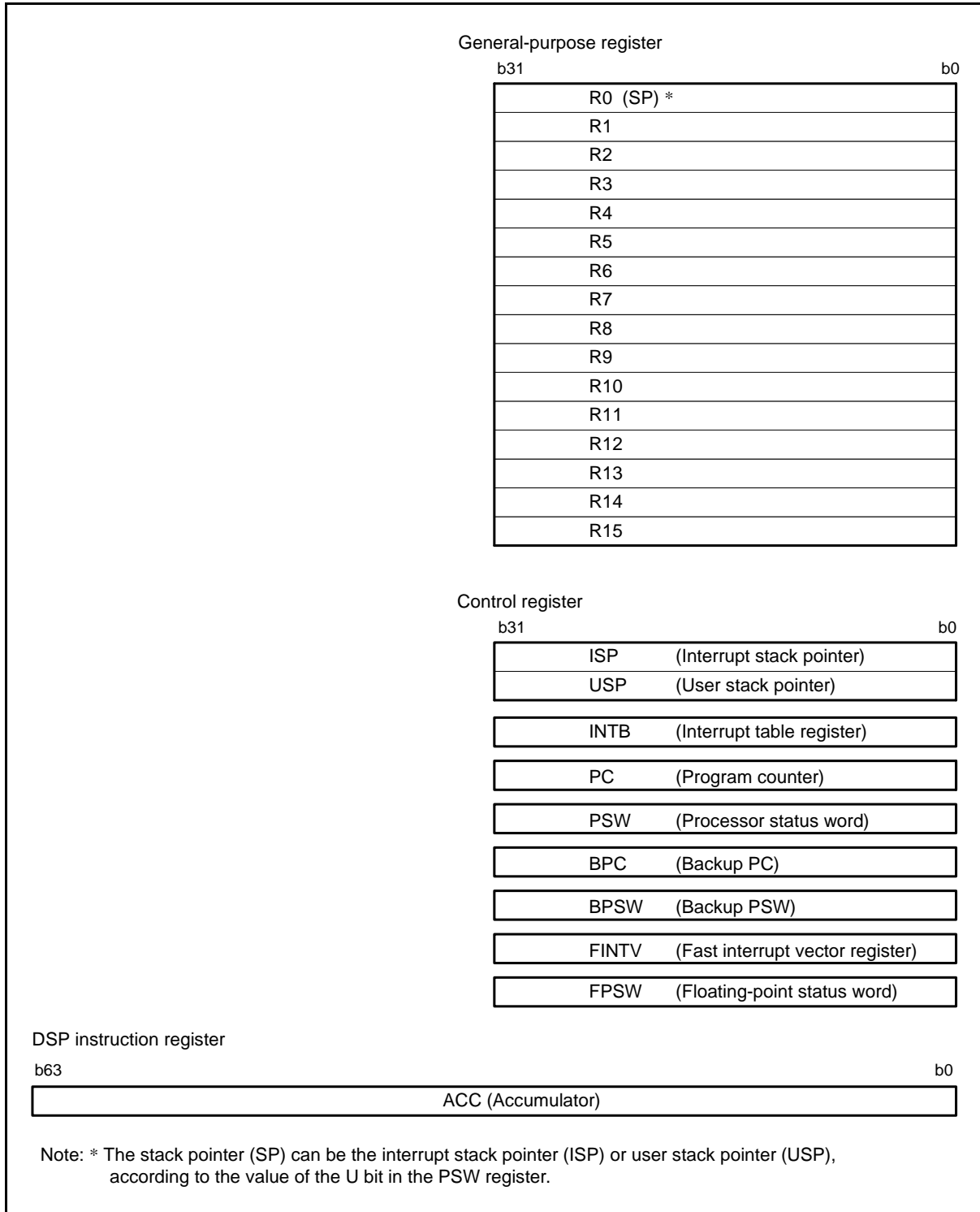

**Figure 2.1 Register Set of the CPU**

## 2.1 General-Purpose Registers (R0 to R15)

This CPU has sixteen general-purpose registers (R0 to R15). R1 to R15 can be used as data registers or address registers. R0, a general-purpose register, also functions as the stack pointer (SP). The stack pointer is switched to operate as the interrupt stack pointer (ISP) or user stack pointer (USP) by the value of the stack pointer select bit (U) in the processor status word (PSW).

## 2.2 Control Registers

### (1) Interrupt Stack Pointer (ISP)/User Stack Pointer (USP)

The stack pointer (SP) can be either of two types, the interrupt stack pointer (ISP) or the user stack pointer (USP). Whether the stack pointer operates as the ISP or USP depends on the value of the stack pointer select bit (U) in the processor status word (PSW).

Set the ISP or USP to a multiple of four, as this reduces the numbers of cycles required to execute interrupt sequences and instructions entailing stack manipulation.

### (2) Interrupt Table Register (INTB)

The interrupt table register (INTB) specifies the address where the relocatable vector table starts. Set INTB to a multiple of four.

### (3) Program Counter (PC)

The program counter (PC) indicates the address of the instruction being executed.

### (4) Processor Status Word (PSW)

The processor status word (PSW) indicates results of instruction execution or the state of the CPU.

### (5) Backup PC (BPC)

The backup PC (BPC) is provided to speed up response to interrupts.

After a fast interrupt has been generated, the contents of the program counter (PC) are saved in the BPC.

### (6) Backup PSW (BPSW)

The backup PSW (BPSW) is provided to speed up response to interrupts.

After a fast interrupt has been generated, the contents of the processor status word (PSW) are saved in the BPSW. The allocation of bits in the BPSW corresponds to that in the PSW.

### (7) Fast Interrupt Vector Register (FINTV)

The fast interrupt vector register (FINTV) is provided to speed up response to interrupts.

The FINTV register specifies a branch destination address when a fast interrupt has been generated.

### (8) Floating-Point Status Word (FPSW)

The floating-point status word (FPSW) indicates the results of floating-point operations.

When an exception handling enable bit (Ej) enables the exception handling (Ej = 1), the exception cause can be identified by checking the corresponding Cj flag in the exception handling routine. If the exception handling is masked (Ej = 0), the occurrence of exception can be checked by reading the Fj flag at the end of a series of processing. Once the Fj flag has been set to 1, this value is retained until it is cleared to 0 by software (j = X, U, Z, O, or V).

### (9) Accumulator (ACC)

The accumulator (ACC) is a 64-bit register used for DSP instructions. The accumulator is also used for the multiply and multiply-and-accumulate instructions; EMUL, EMULU, FMUL, MUL, and RMPA, in which case the prior value in the accumulator is modified by execution of the instruction.

Use the MVTACHI and MVTACLO instructions for writing to the accumulator. The MVTACHI and MVTACLO instructions write data to the higher-order 32 bits (bits 63 to 32) and the lower-order 32 bits (bits 31 to 0), respectively. Use the MVFACHI and MVFACMI instructions for reading data from the accumulator. The MVFACHI and MVFACMI instructions read data from the higher-order 32 bits (bits 63 to 32) and the middle 32 bits (bits 47 to 16), respectively.



### 3. Address Space

#### 3.1 Address Space

This LSI has a 4-Gbyte address space, consisting of the range of addresses from 0000 0000h to FFFF FFFFh. That is, linear access to an address space of up to 4 Gbytes is possible, and this contains both program and data areas. Figure 3.1 shows the memory maps.

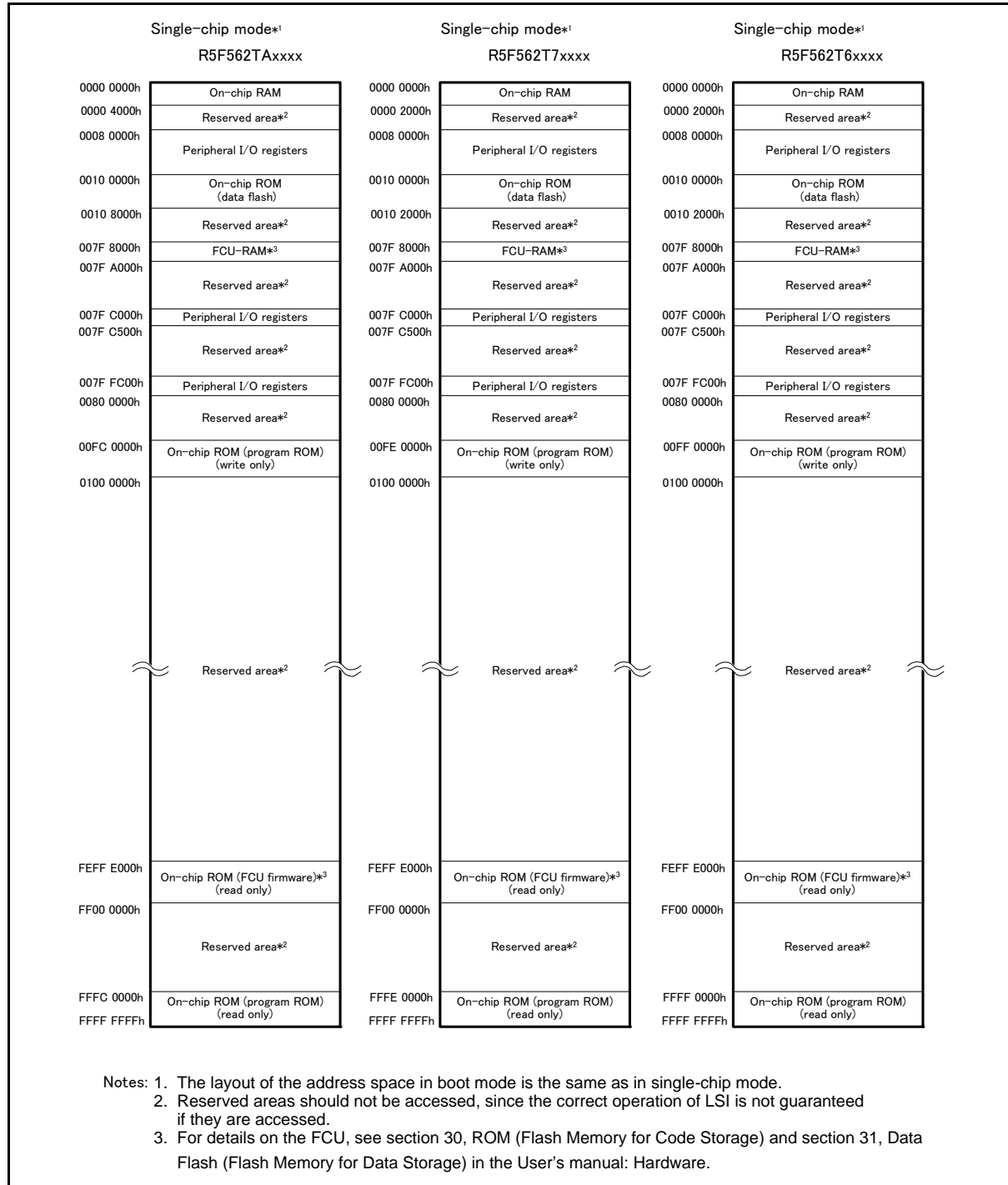

Figure 3.1 Memory Map (RX62T Group)

## 4. I/O Registers

**Table 4.1 List of I/O Registers (Address Order) (1 / 23)**

Address	Module Abbreviation	Register Name	Register Abbreviation	Number of Bits	Access Size	Number of Access Cycles
0008 0000h	SYSTEM	Mode monitor register	MDMONR	16	16	3ICLK
0008 0002h	SYSTEM	Mode status register	MDSR	16	16	3ICLK
0008 0006h	SYSTEM	System control register 0	SYSCR0	16	16	3ICLK
0008 0008h	SYSTEM	System control register 1	SYSCR1	16	16	3ICLK
0008 000Ch	SYSTEM	Standby control register	SBYCR	16	16	3ICLK
0008 0010h	SYSTEM	Module stop control register A	MSTPCRA	32	32	3ICLK
0008 0014h	SYSTEM	Module stop control register B	MSTPCRB	32	32	3ICLK
0008 0018h	SYSTEM	Module stop control register C	MSTPCRC	32	32	3ICLK
0008 0020h	SYSTEM	System clock control register	SCKCR	32	32	3ICLK
0008 0040h	SYSTEM	Oscillation stop detection control register	OSTDCR	16	16	3ICLK
0008 1300h	BSC	Bus error status clear register	BERCLR	8	8	2ICLK
0008 1304h	BSC	Bus error monitoring enable register	BEREN	8	8	2ICLK
0008 1308h	BSC	Bus error status register 1	BERSR1	8	8	2ICLK
0008 130Ah	BSC	Bus error status register 2	BERSR2	16	16	2ICLK
0008 2400h	DTC	DTC control register	DTCCR	8	8	2ICLK
0008 2404h	DTC	DTC vector base register	DTCVBR	32	32	2ICLK
0008 2408h	DTC	DTC address mode register	DTCADMOD	8	8	2ICLK
0008 240Ch	DTC	DTC module start register	DTCST	8	8	2ICLK
0008 240Eh	DTC	DTC status register	DTCSTS	16	16	2ICLK
0008 7010h	ICU	Interrupt request register 016	IR016	8	8	2ICLK
0008 7015h	ICU	Interrupt request register 021	IR021	8	8	2ICLK
0008 7017h	ICU	Interrupt request register 023	IR023	8	8	2ICLK
0008 701Bh	ICU	Interrupt request register 027	IR027	8	8	2ICLK
0008 701Ch	ICU	Interrupt request register 028	IR028	8	8	2ICLK
0008 701Dh	ICU	Interrupt request register 029	IR029	8	8	2ICLK
0008 701Eh	ICU	Interrupt request register 030	IR030	8	8	2ICLK
0008 701Fh	ICU	Interrupt request register 031	IR031	8	8	2ICLK
0008 702Ch	ICU	Interrupt request register 044	IR044	8	8	2ICLK
0008 702Dh	ICU	Interrupt request register 045	IR045	8	8	2ICLK
0008 702Eh	ICU	Interrupt request register 046	IR046	8	8	2ICLK
0008 702Fh	ICU	Interrupt request register 047	IR047	8	8	2ICLK
0008 7038h	ICU	Interrupt request register 056	IR056	8	8	2ICLK
0008 7039h	ICU	Interrupt request register 057	IR057	8	8	2ICLK
0008 703Ah	ICU	Interrupt request register 058	IR058	8	8	2ICLK
0008 703Bh	ICU	Interrupt request register 059	IR059	8	8	2ICLK
0008 703Ch	ICU	Interrupt request register 060	IR060	8	8	2ICLK
0008 7040h	ICU	Interrupt request register 064	IR064	8	8	2ICLK
0008 7041h	ICU	Interrupt request register 065	IR065	8	8	2ICLK
0008 7042h	ICU	Interrupt request register 066	IR066	8	8	2ICLK
0008 7043h	ICU	Interrupt request register 067	IR067	8	8	2ICLK
0008 7044h	ICU	Interrupt request register 068	IR068	8	8	2ICLK
0008 7045h	ICU	Interrupt request register 069	IR069	8	8	2ICLK

**Table 4.1 List of I/O Registers (Address Order) (2 / 23)**

Address	Module Abbreviation	Register Name	Register Abbreviation	Number of Bits	Access Size	Number of Access Cycles
0008 7046h	ICU	Interrupt request register 070	IR070	8	8	2ICLK
0008 7047h	ICU	Interrupt request register 071	IR071	8	8	2ICLK
0008 7060h	ICU	Interrupt request register 096	IR096	8	8	2ICLK
0008 7062h	ICU	Interrupt request register 098	IR098	8	8	2ICLK
0008 7066h	ICU	Interrupt request register 102	IR102	8	8	2ICLK
0008 7067h	ICU	Interrupt request register 103	IR103	8	8	2ICLK
0008 706Ah	ICU	Interrupt request register 106	IR106	8	8	2ICLK
0008 7072h	ICU	Interrupt request register 114	IR114	8	8	2ICLK
0008 7073h	ICU	Interrupt request register 115	IR115	8	8	2ICLK
0008 7074h	ICU	Interrupt request register 116	IR116	8	8	2ICLK
0008 7075h	ICU	Interrupt request register 117	IR117	8	8	2ICLK
0008 7076h	ICU	Interrupt request register 118	IR118	8	8	2ICLK
0008 7077h	ICU	Interrupt request register 119	IR119	8	8	2ICLK
0008 7078h	ICU	Interrupt request register 120	IR120	8	8	2ICLK
0008 7079h	ICU	Interrupt request register 121	IR121	8	8	2ICLK
0008 707Ah	ICU	Interrupt request register 122	IR122	8	8	2ICLK
0008 707Bh	ICU	Interrupt request register 123	IR123	8	8	2ICLK
0008 707Ch	ICU	Interrupt request register 124	IR124	8	8	2ICLK
0008 707Dh	ICU	Interrupt request register 125	IR125	8	8	2ICLK
0008 707Eh	ICU	Interrupt request register 126	IR126	8	8	2ICLK
0008 707Fh	ICU	Interrupt request register 127	IR127	8	8	2ICLK
0008 7080h	ICU	Interrupt request register 128	IR128	8	8	2ICLK
0008 7081h	ICU	Interrupt request register 129	IR129	8	8	2ICLK
0008 7082h	ICU	Interrupt request register 130	IR130	8	8	2ICLK
0008 7083h	ICU	Interrupt request register 131	IR131	8	8	2ICLK
0008 7084h	ICU	Interrupt request register 132	IR132	8	8	2ICLK
0008 7085h	ICU	Interrupt request register 133	IR133	8	8	2ICLK
0008 7086h	ICU	Interrupt request register 134	IR134	8	8	2ICLK
0008 7087h	ICU	Interrupt request register 135	IR135	8	8	2ICLK
0008 7088h	ICU	Interrupt request register 136	IR136	8	8	2ICLK
0008 7089h	ICU	Interrupt request register 137	IR137	8	8	2ICLK
0008 708Ah	ICU	Interrupt request register 138	IR138	8	8	2ICLK
0008 708Bh	ICU	Interrupt request register 139	IR139	8	8	2ICLK
0008 708Ch	ICU	Interrupt request register 140	IR140	8	8	2ICLK
0008 708Dh	ICU	Interrupt request register 141	IR141	8	8	2ICLK
0008 708Eh	ICU	Interrupt request register 142	IR142	8	8	2ICLK
0008 708Fh	ICU	Interrupt request register 143	IR143	8	8	2ICLK
0008 7090h	ICU	Interrupt request register 144	IR144	8	8	2ICLK
0008 7091h	ICU	Interrupt request register 145	IR145	8	8	2ICLK
0008 7092h	ICU	Interrupt request register 146	IR146	8	8	2ICLK
0008 7095h	ICU	Interrupt request register 149	IR149	8	8	2ICLK
0008 7096h	ICU	Interrupt request register 150	IR150	8	8	2ICLK
0008 7097h	ICU	Interrupt request register 151	IR151	8	8	2ICLK
0008 7098h	ICU	Interrupt request register 152	IR152	8	8	2ICLK

**Table 4.1 List of I/O Registers (Address Order) (3 / 23)**

Address	Module Abbreviation	Register Name	Register Abbreviation	Number of Bits	Access Size	Number of Access Cycles
0008 7099h	ICU	Interrupt request register 153	IR153	8	8	2ICLK
0008 70AAh	ICU	Interrupt request register 170	IR170	8	8	2ICLK
0008 70ABh	ICU	Interrupt request register 171	IR171	8	8	2ICLK
0008 70ACh	ICU	Interrupt request register 172	IR172	8	8	2ICLK
0008 70ADh	ICU	Interrupt request register 173	IR173	8	8	2ICLK
0008 70AEh	ICU	Interrupt request register 174	IR174	8	8	2ICLK
0008 70AFh	ICU	Interrupt request register 175	IR175	8	8	2ICLK
0008 70B0h	ICU	Interrupt request register 176	IR176	8	8	2ICLK
0008 70B1h	ICU	Interrupt request register 177	IR177	8	8	2ICLK
0008 70B2h	ICU	Interrupt request register 178	IR178	8	8	2ICLK
0008 70B3h	ICU	Interrupt request register 179	IR179	8	8	2ICLK
0008 70B4h	ICU	Interrupt request register 180	IR180	8	8	2ICLK
0008 70B5h	ICU	Interrupt request register 181	IR181	8	8	2ICLK
0008 70B6h	ICU	Interrupt request register 182	IR182	8	8	2ICLK
0008 70B7h	ICU	Interrupt request register 183	IR183	8	8	2ICLK
0008 70B8h	ICU	Interrupt request register 184	IR184	8	8	2ICLK
0008 70BAh	ICU	Interrupt request register 186	IR186	8	8	2ICLK
0008 70BBh	ICU	Interrupt request register 187	IR187	8	8	2ICLK
0008 70BCh	ICU	Interrupt request register 188	IR188	8	8	2ICLK
0008 70BDh	ICU	Interrupt request register 189	IR189	8	8	2ICLK
0008 70BEh	ICU	Interrupt request register 190	IR190	8	8	2ICLK
0008 70C0h	ICU	Interrupt request register 192	IR192	8	8	2ICLK
0008 70C1h	ICU	Interrupt request register 193	IR193	8	8	2ICLK
0008 70C2h	ICU	Interrupt request register 194	IR194	8	8	2ICLK
0008 70C3h	ICU	Interrupt request register 195	IR195	8	8	2ICLK
0008 70C4h	ICU	Interrupt request register 196	IR196	8	8	2ICLK
0008 70D6h	ICU	Interrupt request register 214	IR214	8	8	2ICLK
0008 70D7h	ICU	Interrupt request register 215	IR215	8	8	2ICLK
0008 70D8h	ICU	Interrupt request register 216	IR216	8	8	2ICLK
0008 70D9h	ICU	Interrupt request register 217	IR217	8	8	2ICLK
0008 70DAh	ICU	Interrupt request register 218	IR218	8	8	2ICLK
0008 70DBh	ICU	Interrupt request register 219	IR219	8	8	2ICLK
0008 70DCh	ICU	Interrupt request register 220	IR220	8	8	2ICLK
0008 70DDh	ICU	Interrupt request register 221	IR221	8	8	2ICLK
0008 70DEh	ICU	Interrupt request register 222	IR222	8	8	2ICLK
0008 70DFh	ICU	Interrupt request register 223	IR223	8	8	2ICLK
0008 70E0h	ICU	Interrupt request register 224	IR224	8	8	2ICLK
0008 70E1h	ICU	Interrupt request register 225	IR225	8	8	2ICLK
0008 70F6h	ICU	Interrupt request register 246	IR246	8	8	2ICLK
0008 70F7h	ICU	Interrupt request register 247	IR247	8	8	2ICLK
0008 70F8h	ICU	Interrupt request register 248	IR248	8	8	2ICLK
0008 70F9h	ICU	Interrupt request register 249	IR249	8	8	2ICLK
0008 70FEh	ICU	Interrupt request register 254	IR254	8	8	2ICLK
0008 711Bh	ICU	DTC activation enable register 027	DT CER027	8	8	2ICLK

**Table 4.1 List of I/O Registers (Address Order) (4 / 23)**

Address	Module Abbreviation	Register Name	Register Abbreviation	Number of Bits	Access Size	Number of Access Cycles
0008 711Ch	ICU	DTC activation enable register 028	DTCER028	8	8	2ICLK
0008 711Dh	ICU	DTC activation enable register 029	DTCER029	8	8	2ICLK
0008 711Eh	ICU	DTC activation enable register 030	DTCER030	8	8	2ICLK
0008 711Fh	ICU	DTC activation enable register 031	DTCER031	8	8	2ICLK
0008 712Dh	ICU	DTC activation enable register 045	DTCER045	8	8	2ICLK
0008 712Eh	ICU	DTC activation enable register 046	DTCER046	8	8	2ICLK
0008 7140h	ICU	DTC activation enable register 064	DTCER064	8	8	2ICLK
0008 7141h	ICU	DTC activation enable register 065	DTCER065	8	8	2ICLK
0008 7142h	ICU	DTC activation enable register 066	DTCER066	8	8	2ICLK
0008 7143h	ICU	DTC activation enable register 067	DTCER067	8	8	2ICLK
0008 7144h	ICU	DTC activation enable register 068	DTCER068	8	8	2ICLK
0008 7145h	ICU	DTC activation enable register 069	DTCER069	8	8	2ICLK
0008 7146h	ICU	DTC activation enable register 070	DTCER070	8	8	2ICLK
0008 7147h	ICU	DTC activation enable register 071	DTCER071	8	8	2ICLK
0008 7162h	ICU	DTC activation enable register 098	DTCER098	8	8	2ICLK
0008 7166h	ICU	DTC activation enable register 102	DTCER102	8	8	2ICLK
0008 7167h	ICU	DTC activation enable register 103	DTCER103	8	8	2ICLK
0008 716Ah	ICU	DTC activation enable register 106	DTCER106	8	8	2ICLK
0008 7172h	ICU	DTC activation enable register 114	DTCER114	8	8	2ICLK
0008 7173h	ICU	DTC activation enable register 115	DTCER115	8	8	2ICLK
0008 7174h	ICU	DTC activation enable register 116	DTCER116	8	8	2ICLK
0008 7175h	ICU	DTC activation enable register 117	DTCER117	8	8	2ICLK
0008 7179h	ICU	DTC activation enable register 121	DTCER121	8	8	2ICLK
0008 717Ah	ICU	DTC activation enable register 122	DTCER122	8	8	2ICLK
0008 717Dh	ICU	DTC activation enable register 125	DTCER125	8	8	2ICLK
0008 717Eh	ICU	DTC activation enable register 126	DTCER126	8	8	2ICLK
0008 7181h	ICU	DTC activation enable register 129	DTCER129	8	8	2ICLK
0008 7182h	ICU	DTC activation enable register 130	DTCER130	8	8	2ICLK
0008 7183h	ICU	DTC activation enable register 131	DTCER131	8	8	2ICLK
0008 7184h	ICU	DTC activation enable register 132	DTCER132	8	8	2ICLK
0008 7186h	ICU	DTC activation enable register 134	DTCER134	8	8	2ICLK
0008 7187h	ICU	DTC activation enable register 135	DTCER135	8	8	2ICLK
0008 7188h	ICU	DTC activation enable register 136	DTCER136	8	8	2ICLK
0008 7189h	ICU	DTC activation enable register 137	DTCER137	8	8	2ICLK
0008 718Ah	ICU	DTC activation enable register 138	DTCER138	8	8	2ICLK
0008 718Bh	ICU	DTC activation enable register 139	DTCER139	8	8	2ICLK
0008 718Ch	ICU	DTC activation enable register 140	DTCER140	8	8	2ICLK
0008 718Dh	ICU	DTC activation enable register 141	DTCER141	8	8	2ICLK
0008 718Eh	ICU	DTC activation enable register 142	DTCER142	8	8	2ICLK
0008 718Fh	ICU	DTC activation enable register 143	DTCER143	8	8	2ICLK
0008 7190h	ICU	DTC activation enable register 144	DTCER144	8	8	2ICLK
0008 7191h	ICU	DTC activation enable register 145	DTCER145	8	8	2ICLK
0008 7195h	ICU	DTC activation enable register 149	DTCER149	8	8	2ICLK
0008 7196h	ICU	DTC activation enable register 150	DTCER150	8	8	2ICLK

**Table 4.1 List of I/O Registers (Address Order) (5 / 23)**

Address	Module Abbreviation	Register Name	Register Abbreviation	Number of Bits	Access Size	Number of Access Cycles
0008 7197h	ICU	DTC activation enable register 151	DTCER151	8	8	2ICLK
0008 7198h	ICU	DTC activation enable register 152	DTCER152	8	8	2ICLK
0008 7199h	ICU	DTC activation enable register 153	DTCER153	8	8	2ICLK
0008 71AEh	ICU	DTC activation enable register 174	DTCER174	8	8	2ICLK
0008 71AFh	ICU	DTC activation enable register 175	DTCER175	8	8	2ICLK
0008 71B0h	ICU	DTC activation enable register 176	DTCER176	8	8	2ICLK
0008 71B1h	ICU	DTC activation enable register 177	DTCER177	8	8	2ICLK
0008 71B2h	ICU	DTC activation enable register 178	DTCER178	8	8	2ICLK
0008 71B3h	ICU	DTC activation enable register 179	DTCER179	8	8	2ICLK
0008 71B4h	ICU	DTC activation enable register 180	DTCER180	8	8	2ICLK
0008 71B5h	ICU	DTC activation enable register 181	DTCER181	8	8	2ICLK
0008 71B6h	ICU	DTC activation enable register 182	DTCER182	8	8	2ICLK
0008 71B7h	ICU	DTC activation enable register 183	DTCER183	8	8	2ICLK
0008 71B8h	ICU	DTC activation enable register 184	DTCER184	8	8	2ICLK
0008 71BAh	ICU	DTC activation enable register 186	DTCER186	8	8	2ICLK
0008 71BBh	ICU	DTC activation enable register 187	DTCER187	8	8	2ICLK
0008 71BCh	ICU	DTC activation enable register 188	DTCER188	8	8	2ICLK
0008 71BDh	ICU	DTC activation enable register 189	DTCER189	8	8	2ICLK
0008 71BEh	ICU	DTC activation enable register 190	DTCER190	8	8	2ICLK
0008 71C0h	ICU	DTC activation enable register 192	DTCER192	8	8	2ICLK
0008 71C1h	ICU	DTC activation enable register 193	DTCER193	8	8	2ICLK
0008 71C2h	ICU	DTC activation enable register 194	DTCER194	8	8	2ICLK
0008 71C3h	ICU	DTC activation enable register 195	DTCER195	8	8	2ICLK
0008 71C4h	ICU	DTC activation enable register 196	DTCER196	8	8	2ICLK
0008 71D7h	ICU	DTC activation enable register 215	DTCER215	8	8	2ICLK
0008 71D8h	ICU	DTC activation enable register 216	DTCER216	8	8	2ICLK
0008 71DBh	ICU	DTC activation enable register 219	DTCER219	8	8	2ICLK
0008 71DCh	ICU	DTC activation enable register 220	DTCER220	8	8	2ICLK
0008 71DFh	ICU	DTC activation enable register 223	DTCER223	8	8	2ICLK
0008 71E0h	ICU	DTC activation enable register 224	DTCER224	8	8	2ICLK
0008 71F7h	ICU	DTC activation enable register 247	DTCER247	8	8	2ICLK
0008 71F8h	ICU	DTC activation enable register 248	DTCER248	8	8	2ICLK
0008 71FEh	ICU	DTC activation enable register 254	DTCER254	8	8	2ICLK
0008 7202h	ICU	Interrupt request enable register 02	IER02	8	8	2ICLK
0008 7203h	ICU	Interrupt request enable register 03	IER03	8	8	2ICLK
0008 7205h	ICU	Interrupt request enable register 05	IER05	8	8	2ICLK
0008 7207h	ICU	Interrupt request enable register 07	IER07	8	8	2ICLK
0008 7208h	ICU	Interrupt request enable register 08	IER08	8	8	2ICLK
0008 720Ch	ICU	Interrupt request enable register 0C	IER0C	8	8	2ICLK
0008 720Dh	ICU	Interrupt request enable register 0D	IER0D	8	8	2ICLK
0008 720Eh	ICU	Interrupt request enable register 0E	IER0E	8	8	2ICLK
0008 720Fh	ICU	Interrupt request enable register 0F	IER0F	8	8	2ICLK
0008 7210h	ICU	Interrupt request enable register 10	IER10	8	8	2ICLK
0008 7211h	ICU	Interrupt request enable register 11	IER11	8	8	2ICLK

**Table 4.1 List of I/O Registers (Address Order) (6 / 23)**

Address	Module Abbreviation	Register Name	Register Abbreviation	Number of Bits	Access Size	Number of Access Cycles
0008 7212h	ICU	Interrupt request enable register 12	IER12	8	8	2ICLK
0008 7213h	ICU	Interrupt request enable register 13	IER13	8	8	2ICLK
0008 7215h	ICU	Interrupt request enable register 15	IER15	8	8	2ICLK
0008 7216h	ICU	Interrupt request enable register 16	IER16	8	8	2ICLK
0008 7217h	ICU	Interrupt request enable register 17	IER17	8	8	2ICLK
0008 7218h	ICU	Interrupt request enable register 18	IER18	8	8	2ICLK
0008 721Ah	ICU	Interrupt request enable register 1A	IER1A	8	8	2ICLK
0008 721Bh	ICU	Interrupt request enable register 1B	IER1B	8	8	2ICLK
0008 721Ch	ICU	Interrupt request enable register 1C	IER1C	8	8	2ICLK
0008 721Eh	ICU	Interrupt request enable register 1E	IER1E	8	8	2ICLK
0008 721Fh	ICU	Interrupt request enable register 1F	IER1F	8	8	2ICLK
0008 72E0h	ICU	Software interrupt activation register	SWINTR	8	8	2ICLK
0008 72F0h	ICU	Fast interrupt set register	FIR	16	16	2ICLK
0008 7300h	ICU	Interrupt source priority register 00	IPR00	8	8	2ICLK
0008 7301h	ICU	Interrupt source priority register 01	IPR01	8	8	2ICLK
0008 7302h	ICU	Interrupt source priority register 02	IPR02	8	8	2ICLK
0008 7303h	ICU	Interrupt source priority register 03	IPR03	8	8	2ICLK
0008 7304h	ICU	Interrupt source priority register 04	IPR04	8	8	2ICLK
0008 7305h	ICU	Interrupt source priority register 05	IPR05	8	8	2ICLK
0008 7306h	ICU	Interrupt source priority register 06	IPR06	8	8	2ICLK
0008 7307h	ICU	Interrupt source priority register 07	IPR07	8	8	2ICLK
0008 7314h	ICU	Interrupt source priority register 14	IPR14	8	8	2ICLK
0008 7318h	ICU	Interrupt source priority register 18	IPR18	8	8	2ICLK
0008 7320h	ICU	Interrupt source priority register 20	IPR20	8	8	2ICLK
0008 7321h	ICU	Interrupt source priority register 21	IPR21	8	8	2ICLK
0008 7322h	ICU	Interrupt source priority register 22	IPR22	8	8	2ICLK
0008 7323h	ICU	Interrupt source priority register 23	IPR23	8	8	2ICLK
0008 7324h	ICU	Interrupt source priority register 24	IPR24	8	8	2ICLK
0008 7325h	ICU	Interrupt source priority register 25	IPR25	8	8	2ICLK
0008 7326h	ICU	Interrupt source priority register 26	IPR26	8	8	2ICLK
0008 7327h	ICU	Interrupt source priority register 27	IPR27	8	8	2ICLK
0008 7340h	ICU	Interrupt source priority register 40	IPR40	8	8	2ICLK
0008 7344h	ICU	Interrupt source priority register 44	IPR44	8	8	2ICLK
0008 7348h	ICU	Interrupt source priority register 48	IPR48	8	8	2ICLK
0008 7349h	ICU	Interrupt source priority register 49	IPR49	8	8	2ICLK
0008 7351h	ICU	Interrupt source priority register 51	IPR51	8	8	2ICLK
0008 7352h	ICU	Interrupt source priority register 52	IPR52	8	8	2ICLK
0008 7353h	ICU	Interrupt source priority register 53	IPR53	8	8	2ICLK
0008 7354h	ICU	Interrupt source priority register 54	IPR54	8	8	2ICLK
0008 7355h	ICU	Interrupt source priority register 55	IPR55	8	8	2ICLK
0008 7356h	ICU	Interrupt source priority register 56	IPR56	8	8	2ICLK
0008 7357h	ICU	Interrupt source priority register 57	IPR57	8	8	2ICLK
0008 7358h	ICU	Interrupt source priority register 58	IPR58	8	8	2ICLK
0008 7359h	ICU	Interrupt source priority register 59	IPR59	8	8	2ICLK

**Table 4.1 List of I/O Registers (Address Order) (7 / 23)**

Address	Module Abbreviation	Register Name	Register Abbreviation	Number of Bits	Access Size	Number of Access Cycles
0008 735Ah	ICU	Interrupt source priority register 5A	IPR5A	8	8	2ICLK
0008 735Bh	ICU	Interrupt source priority register 5B	IPR5B	8	8	2ICLK
0008 735Ch	ICU	Interrupt source priority register 5C	IPR5C	8	8	2ICLK
0008 735Dh	ICU	Interrupt source priority register 5D	IPR5D	8	8	2ICLK
0008 735Eh	ICU	Interrupt source priority register 5E	IPR5E	8	8	2ICLK
0008 735Fh	ICU	Interrupt source priority register 5F	IPR5F	8	8	2ICLK
0008 7360h	ICU	Interrupt source priority register 60	IPR60	8	8	2ICLK
0008 7367h	ICU	Interrupt source priority register 67	IPR67	8	8	2ICLK
0008 7368h	ICU	Interrupt source priority register 68	IPR68	8	8	2ICLK
0008 7369h	ICU	Interrupt source priority register 69	IPR69	8	8	2ICLK
0008 736Ah	ICU	Interrupt source priority register 6A	IPR6A	8	8	2ICLK
0008 736Bh	ICU	Interrupt source priority register 6B	IPR6B	8	8	2ICLK
0008 736Ch	ICU	Interrupt source priority register 6C	IPR6C	8	8	2ICLK
0008 736Dh	ICU	Interrupt source priority register 6D	IPR6D	8	8	2ICLK
0008 736Eh	ICU	Interrupt source priority register 6E	IPR6E	8	8	2ICLK
0008 736Fh	ICU	Interrupt source priority register 6F	IPR6F	8	8	2ICLK
0008 7380h	ICU	Interrupt source priority register 80	IPR80	8	8	2ICLK
0008 7381h	ICU	Interrupt source priority register 81	IPR81	8	8	2ICLK
0008 7382h	ICU	Interrupt source priority register 82	IPR82	8	8	2ICLK
0008 7388h	ICU	Interrupt source priority register 88	IPR88	8	8	2ICLK
0008 7389h	ICU	Interrupt source priority register 89	IPR89	8	8	2ICLK
0008 738Ah	ICU	Interrupt source priority register 8A	IPR8A	8	8	2ICLK
0008 738Bh	ICU	Interrupt source priority register 8B	IPR8B	8	8	2ICLK
0008 7390h	ICU	Interrupt source priority register 90	IPR90	8	8	2ICLK
0008 7500h	ICU	IRQ control register 0	IRQCR0	8	8	2ICLK
0008 7501h	ICU	IRQ control register 1	IRQCR1	8	8	2ICLK
0008 7502h	ICU	IRQ control register 2	IRQCR2	8	8	2ICLK
0008 7503h	ICU	IRQ control register 3	IRQCR3	8	8	2ICLK
0008 7504h	ICU	IRQ control register 4	IRQCR4	8	8	2ICLK
0008 7505h	ICU	IRQ control register 5	IRQCR5	8	8	2ICLK
0008 7506h	ICU	IRQ control register 6	IRQCR6	8	8	2ICLK
0008 7507h	ICU	IRQ control register 7	IRQCR7	8	8	2ICLK
0008 7580h	ICU	Non-maskable interrupt status register	NMISR	8	8	2ICLK
0008 7581h	ICU	Non-maskable interrupt enable register	NMIER	8	8	2ICLK
0008 7582h	ICU	Non-maskable interrupt clear register	NMICLR	8	8	2ICLK
0008 7583h	ICU	NMI pin interrupt control register	NMICR	8	8	2ICLK
0008 8000h	CMT	Compare match timer start register 0	CMSTR0	16	16	2 to 3PCLK <sup>5</sup>
0008 8002h	CMT0	Compare match timer control register	CMCR	16	16	2 to 3PCLK <sup>5</sup>
0008 8004h	CMT0	Compare match timer counter	CMCNT	16	16	2 to 3PCLK <sup>5</sup>
0008 8006h	CMT0	Compare match timer constant register	CMCOR	16	16	2 to 3PCLK <sup>5</sup>
0008 8008h	CMT1	Compare match timer control register	CMCR	16	16	2 to 3PCLK <sup>5</sup>
0008 800Ah	CMT1	Compare match timer counter	CMCNT	16	16	2 to 3PCLK <sup>5</sup>
0008 800Ch	CMT1	Compare match timer constant register	CMCOR	16	16	2 to 3PCLK <sup>5</sup>
0008 8010h	CMT	Compare match timer start register 1	CMSTR1	16	16	2 to 3PCLK <sup>5</sup>



**Table 4.1 List of I/O Registers (Address Order) (8 / 23)**

Address	Module Abbreviation	Register Name	Register Abbreviation	Number of Bits	Access Size	Number of Access Cycles
0008 8012h	CMT2	Compare match timer control register	CMCR	16	16	2 to 3PCLK <sup>*5</sup>
0008 8014h	CMT2	Compare match timer counter	CMCNT	16	16	2 to 3PCLK <sup>*5</sup>
0008 8016h	CMT2	Compare match timer constant register	CMCOR	16	16	2 to 3PCLK <sup>*5</sup>
0008 8018h	CMT3	Compare match timer control register	CMCR	16	16	2 to 3PCLK <sup>*5</sup>
0008 801Ah	CMT3	Compare match timer counter	CMCNT	16	16	2 to 3PCLK <sup>*5</sup>
0008 801Ch	CMT3	Compare match timer constant register	CMCOR	16	16	2 to 3PCLK <sup>*5</sup>
0008 8028h	WDT	Timer control/status register	TCSR	8	8	2 to 3PCLK <sup>*5</sup>
0008 8028h	WDT	Write window A register	WINA	16	16	2 to 3PCLK <sup>*5</sup>
0008 8029h	WDT	Timer counter	TCNT	8	8	2 to 3PCLK <sup>*5</sup>
0008 802Ah	WDT	Write window B register	WINB	16	16	2 to 3PCLK <sup>*5</sup>
0008 802Bh	WDT	Reset control/status register	RSTCSR	8	8	2 to 3PCLK <sup>*5</sup>
0008 8030h	IWDT	IWDT refresh register	IWDTRR	8	8	2 to 3PCLK <sup>*5</sup>
0008 8032h	IWDT	IWDT control register	IWDTCR	16	16	2 to 3PCLK <sup>*5</sup>
0008 8034h	IWDT	IWDT status register	IWDTSR	16	16	2 to 3PCLK <sup>*5</sup>
0008 8040h	ADA	A/D data register A	ADDRA	16	16	2 to 3PCLK <sup>*5</sup>
0008 8042h	ADA	A/D data register B	ADDRB	16	16	2 to 3PCLK <sup>*5</sup>
0008 8044h	ADA	A/D data register C	ADDRC	16	16	2 to 3PCLK <sup>*5</sup>
0008 8046h	ADA	A/D data register D	ADDRD	16	16	2 to 3PCLK <sup>*5</sup>
0008 8048h	ADA	A/D data register E	ADDRE	16	16	2 to 3PCLK <sup>*5</sup>
0008 804Ah	ADA	A/D data register F	ADDRF	16	16	2 to 3PCLK <sup>*5</sup>
0008 804Ch	ADA	A/D data register G	ADDRG	16	16	2 to 3PCLK <sup>*5</sup>
0008 804Eh	ADA	A/D data register H	ADDRH	16	16	2 to 3PCLK <sup>*5</sup>
0008 8050h	ADA	A/D control/status register	ADCSR	8	8	2 to 3PCLK <sup>*5</sup>
0008 8051h	ADA	A/D control register	ADCR	8	8	2 to 3PCLK <sup>*5</sup>
0008 805Bh	ADA	A/D sampling state register	ADSSTR	8	8	2 to 3PCLK <sup>*5</sup>
0008 805Dh	ADA	A/D self-diagnostic register	ADDIAGR	8	8	2 to 3PCLK <sup>*5</sup>
0008 8060h	ADA	A/D data register I	ADDRI	16	16	2 to 3PCLK <sup>*5</sup>
0008 8062h	ADA	A/D data register J	ADDRJ	16	16	2 to 3PCLK <sup>*5</sup>
0008 8064h	ADA	A/D data register K	ADDRK	16	16	2 to 3PCLK <sup>*5</sup>
0008 8066h	ADA	A/D data register L	ADDRL	16	16	2 to 3PCLK <sup>*5</sup>
0008 8070h	ADA	A/D start trigger select register	ADSTRGR	8	8	2 to 3PCLK <sup>*5</sup>
0008 8072h	ADA	A/D data placement register	ADDPR	8	8	2 to 3PCLK <sup>*5</sup>
0008 8240h	SCIO	Serial mode register	SMR <sup>*1</sup>	8	8	2 to 3PCLK <sup>*5</sup>
0008 8241h	SCIO	Bit rate register	BRR	8	8	2 to 3PCLK <sup>*5</sup>
0008 8242h	SCIO	Serial control register	SCR <sup>*1</sup>	8	8	2 to 3PCLK <sup>*5</sup>
0008 8243h	SCIO	Transmit data register	TDR	8	8	2 to 3PCLK <sup>*5</sup>
0008 8244h	SCIO	Serial status register	SSR <sup>*1</sup>	8	8	2 to 3PCLK <sup>*5</sup>
0008 8245h	SCIO	Receive data register	RDR	8	8	2 to 3PCLK <sup>*5</sup>
0008 8246h	SCIO	Smart card mode register	SCMR	8	8	2 to 3PCLK <sup>*5</sup>
0008 8247h	SCIO	Serial extended mode register	SEMR	8	8	2 to 3PCLK <sup>*5</sup>
0008 8240h	SMCIO	Serial mode register	SMR	8	8	2 to 3PCLK <sup>*5</sup>
0008 8241h	SMCIO	Bit rate register	BRR	8	8	2 to 3PCLK <sup>*5</sup>
0008 8242h	SMCIO	Serial control register	SCR	8	8	2 to 3PCLK <sup>*5</sup>
0008 8243h	SMCIO	Transmit data register	TDR	8	8	2 to 3PCLK <sup>*5</sup>

**Table 4.1 List of I/O Registers (Address Order) (9 / 23)**

Address	Module Abbreviation	Register Name	Register Abbreviation	Number of Bits	Access Size	Number of Access Cycles
0008 8244h	SMCI0	Serial status register	SSR	8	8	2 to 3PCLK*5
0008 8245h	SMCI0	Receive data register	RDR	8	8	2 to 3PCLK*5
0008 8246h	SMCI0	Smart card mode register	SCMR	8	8	2 to 3PCLK*5
0008 8248h	SCI1	Serial mode register	SMR <sup>*1</sup>	8	8	2 to 3PCLK*5
0008 8249h	SCI1	Bit rate register	BRR	8	8	2 to 3PCLK*5
0008 824Ah	SCI1	Serial control register	SCR <sup>*1</sup>	8	8	2 to 3PCLK*5
0008 824Bh	SCI1	Transmit data register	TDR	8	8	2 to 3PCLK*5
0008 824Ch	SCI1	Serial status register	SSR <sup>*1</sup>	8	8	2 to 3PCLK*5
0008 824Dh	SCI1	Receive data register	RDR	8	8	2 to 3PCLK*5
0008 824Eh	SCI1	Smart card mode register	SCMR	8	8	2 to 3PCLK*5
0008 824Fh	SCI1	Serial extended mode register	SEMR	8	8	2 to 3PCLK*5
0008 8248h	SMCI1	Serial mode register	SMR	8	8	2 to 3PCLK*5
0008 8249h	SMCI1	Bit rate register	BRR	8	8	2 to 3PCLK*5
0008 824Ah	SMCI1	Serial control register	SCR	8	8	2 to 3PCLK*5
0008 824Bh	SMCI1	Transmit data register	TDR	8	8	2 to 3PCLK*5
0008 824Ch	SMCI1	Serial status register	SSR	8	8	2 to 3PCLK*5
0008 824Dh	SMCI1	Receive data register	RDR	8	8	2 to 3PCLK*5
0008 824Eh	SMCI1	Smart card mode register	SCMR	8	8	2 to 3PCLK*5
0008 8250h	SCI2	Serial mode register	SMR <sup>*1</sup>	8	8	2 to 3PCLK*5
0008 8251h	SCI2	Bit rate register	BRR	8	8	2 to 3PCLK*5
0008 8252h	SCI2	Serial control register	SCR <sup>*1</sup>	8	8	2 to 3PCLK*5
0008 8253h	SCI2	Transmit data register	TDR	8	8	2 to 3PCLK*5
0008 8254h	SCI2	Serial status register	SSR <sup>*1</sup>	8	8	2 to 3PCLK*5
0008 8255h	SCI2	Receive data register	RDR	8	8	2 to 3PCLK*5
0008 8256h	SCI2	Smart card mode register	SCMR	8	8	2 to 3PCLK*5
0008 8257h	SCI2	Serial extended mode register	SEMR	8	8	2 to 3PCLK*5
0008 8250h	SMCI2	Serial mode register	SMR <sup>*1</sup>	8	8	2 to 3PCLK*5
0008 8251h	SMCI2	Bit rate register	BRR	8	8	2 to 3PCLK*5
0008 8252h	SMCI2	Serial control register	SCR <sup>*1</sup>	8	8	2 to 3PCLK*5
0008 8253h	SMCI2	Transmit data register	TDR	8	8	2 to 3PCLK*5
0008 8254h	SMCI2	Serial status register	SSR <sup>*1</sup>	8	8	2 to 3PCLK*5
0008 8255h	SMCI2	Receive data register	RDR	8	8	2 to 3PCLK*5
0008 8256h	SMCI2	Smart card mode register	SCMR	8	8	2 to 3PCLK*5
0008 8280h	CRC	CRC control register	CRCCR	8	8	2 to 3PCLK*5
0008 8281h	CRC	CRC data input register	CRCDIR	8	8	2 to 3PCLK*5
0008 8282h	CRC	CRC data output register	CRCDOR	16	16	2 to 3PCLK*5
0008 8300h	RIIC	I <sup>2</sup> C bus control register 1	ICCR1	8	8	2 to 3PCLK*5
0008 8301h	RIIC	I <sup>2</sup> C bus control register 2	ICCR2	8	8	2 to 3PCLK*5
0008 8302h	RIIC	I <sup>2</sup> C bus mode register 1	ICMR1	8	8	2 to 3PCLK*5
0008 8303h	RIIC	I <sup>2</sup> C bus mode register 2	ICMR2	8	8	2 to 3PCLK*5
0008 8304h	RIIC	I <sup>2</sup> C bus mode register 3	ICMR3	8	8	2 to 3PCLK*5
0008 8305h	RIIC	I <sup>2</sup> C bus function enable register	ICFER	8	8	2 to 3PCLK*5
0008 8306h	RIIC	I <sup>2</sup> C bus status enable register	ICSER	8	8	2 to 3PCLK*5
0008 8307h	RIIC	I <sup>2</sup> C bus interrupt enable register	ICIER	8	8	2 to 3PCLK*5

**Table 4.1 List of I/O Registers (Address Order) (10 / 23)**

Address	Module Abbreviation	Register Name	Register Abbreviation	Number of Bits	Access Size	Number of Access Cycles
0008 8308h	RIIC	I <sup>2</sup> C bus status register 1	ICSR1	8	8	2 to 3PCLK*5
0008 8309h	RIIC	I <sup>2</sup> C bus status register 2	ICSR2	8	8	2 to 3PCLK*5
0008 830Ah	RIIC	Slave address register L0	SARL0	8	8	2 to 3PCLK*5
0008 830Bh	RIIC	Slave address register U0	SARU0	8	8	2 to 3PCLK*5
0008 830Ch	RIIC	Slave address register L1	SARL1	8	8	2 to 3PCLK*5
0008 830Dh	RIIC	Slave address register U1	SARU1	8	8	2 to 3PCLK*5
0008 830Eh	RIIC	Slave address register L2	SARL2	8	8	2 to 3PCLK*5
0008 830Fh	RIIC	Slave address register U2	SARU2	8	8	2 to 3PCLK*5
0008 8310h	RIIC	I <sup>2</sup> C bus bit rate low-level register	ICBRL	8	8	2 to 3PCLK*5
0008 8311h	RIIC	I <sup>2</sup> C bus bit rate high-level register	ICBRH	8	8	2 to 3PCLK*5
0008 8312h	RIIC	I <sup>2</sup> C bus transmit data register	ICDRT	8	8	2 to 3PCLK*5
0008 8313h	RIIC	I <sup>2</sup> C bus receive data register	ICDRR	8	8	2 to 3PCLK*5
0008 8380h	RSPI	RSPI control register	SPCR	8	8	2 to 3PCLK*5
0008 8381h	RSPI	RSPI slave select polarity register	SSLP	8	8	2 to 3PCLK*5
0008 8382h	RSPI	RSPI pin control register	SPPCR	8	8	2 to 3PCLK*5
0008 8383h	RSPI	RSPI status register	SPSR	8	8	2 to 3PCLK*5
0008 8384h	RSPI	RSPI data register	SPDR	16, 32	16, 32	2 to 3PCLK*5
0008 8388h	RSPI	RSPI sequence control register	SPSCR	8	8	2 to 3PCLK*5
0008 8389h	RSPI	RSPI sequence status register	SPSSR	8	8	2 to 3PCLK*5
0008 838Ah	RSPI	RSPI bit rate register	SPBR	8	8	2 to 3PCLK*5
0008 838Bh	RSPI	RSPI data control register	SPDCR	8	8	2 to 3PCLK*5
0008 838Ch	RSPI	RSPI clock delay register	SPCKD	8	8	2 to 3PCLK*5
0008 838Dh	RSPI	RSPI slave select negation delay register	SSLND	8	8	2 to 3PCLK*5
0008 838Eh	RSPI	RSPI next-access delay register	SPND	8	8	2 to 3PCLK*5
0008 838Fh	RSPI	RSPI control register 2	SPCR2	8	8	2 to 3PCLK*5
0008 8390h	RSPI	RSPI command register 0	SPCMD0	16	16	2 to 3PCLK*5
0008 8392h	RSPI	RSPI command register 1	SPCMD1	16	16	2 to 3PCLK*5
0008 8394h	RSPI	RSPI command register 2	SPCMD2	16	16	2 to 3PCLK*5
0008 8396h	RSPI	RSPI command register 3	SPCMD3	16	16	2 to 3PCLK*5
0008 8398h	RSPI	RSPI command register 4	SPCMD4	16	16	2 to 3PCLK*5
0008 839Ah	RSPI	RSPI command register 5	SPCMD5	16	16	2 to 3PCLK*5
0008 839Ch	RSPI	RSPI command register 6	SPCMD6	16	16	2 to 3PCLK*5
0008 839Eh	RSPI	RSPI command register 7	SPCMD7	16	16	2 to 3PCLK*5
0008 9000h	S12AD0	A/D control register	ADCSR	8	8	2 to 3PCLK*5
0008 9004h	S12AD0	A/D channel select register	ADANS	16	16	2 to 3PCLK*5
0008 900Ah	S12AD0	A/D programmable gain amplifier register	ADPG	16	16	2 to 3PCLK*5
0008 900Eh	S12AD0	A/D control extended register	ADCER	16	16	2 to 3PCLK*5
0008 9010h	S12AD0	A/D start trigger select register	ADSTRGR	16	16	2 to 3PCLK*5
0008 9012h	S12AD	Comparator operating mode select register 0	ADCMPMD0	16	16	2 to 3PCLK*5
0008 9014h	S12AD	Comparator operating mode select register 1	ADCMPMD1	16	16	2 to 3PCLK*5
0008 9016h	S12AD	Comparator filter mode register 0	ADCMPNR0	16	16	2 to 3PCLK*5
0008 9018h	S12AD	Comparator filter mode register 1	ADCMPNR1	16	16	2 to 3PCLK*5
0008 901Ah	S12AD	Comparator detection flag register	ADCMPFR	8	8	2 to 3PCLK*5
0008 901Ch	S12AD	Comparator interrupt select register	ADCMPSEL	16	16	2 to 3PCLK*5

**Table 4.1 List of I/O Registers (Address Order) (11 / 23)**

Address	Module Abbreviation	Register Name	Register Abbreviation	Number of Bits	Access Size	Number of Access Cycles
0008 901Eh	S12AD0	A/D data register Diag	ADRD	16	16	2 to 3PCLK*5
0008 9020h	S12AD0	A/D data register 0A	ADDR0A	16	16	2 to 3PCLK*5
0008 9022h	S12AD0	A/D data register 1	ADDR1	16	16	2 to 3PCLK*5
0008 9024h	S12AD0	A/D data register 2	ADDR2	16	16	2 to 3PCLK*5
0008 9026h	S12AD0	A/D data register 3	ADDR3	16	16	2 to 3PCLK*5
0008 9030h	S12AD0	A/D data register 0B	ADDR0B	16	16	2 to 3PCLK*5
0008 9060h	S12AD0	A/D sampling state register	ADSSTR	8	8	2 to 3PCLK*5
0008 9080h	S12AD1	A/D control register	ADCSR	8	8	2 to 3PCLK*5
0008 9084h	S12AD1	A/D channel select register	ADANS	16	16	2 to 3PCLK*5
0008 908Ah	S12AD1	A/D programmable gain amplifier register	ADPG	16	16	2 to 3PCLK*5
0008 908Eh	S12AD1	A/D control extended register	ADCER	16	16	2 to 3PCLK*5
0008 9090h	S12AD1	A/D start trigger select register	ADSTRGR	16	16	2 to 3PCLK*5
0008 909Eh	S12AD1	A/D data register Diag	ADRD	16	16	2 to 3PCLK*5
0008 90A0h	S12AD1	A/D data register 0A	ADDR0A	16	16	2 to 3PCLK*5
0008 90A2h	S12AD1	A/D data register 1	ADDR1	16	16	2 to 3PCLK*5
0008 90A4h	S12AD1	A/D data register 2	ADDR2	16	16	2 to 3PCLK*5
0008 90A6h	S12AD1	A/D data register 3	ADDR3	16	16	2 to 3PCLK*5
0008 90B0h	S12AD1	A/D data register 0B	ADDR0B	16	16	2 to 3PCLK*5
0008 90E0h	S12AD1	A/D sampling state register	ADSSTR	8	8	2 to 3PCLK*5
0008 C001h	PORT1	Data direction register	DDR	8	8	2 to 3PCLK*5
0008 C002h	PORT2	Data direction register	DDR	8	8	2 to 3PCLK*5
0008 C003h	PORT3	Data direction register	DDR	8	8	2 to 3PCLK*5
0008 C007h	PORT7	Data direction register	DDR	8	8	2 to 3PCLK*5
0008 C008h	PORT8	Data direction register	DDR*2*3	8	8	2 to 3PCLK*5
0008 C009h	PORT9	Data direction register	DDR	8	8	2 to 3PCLK*5
0008 C00Ah	PORTA	Data direction register	DDR	8	8	2 to 3PCLK*5
0008 C00Bh	PORTB	Data direction register	DDR	8	8	2 to 3PCLK*5
0008 C00Dh	PORTD	Data direction register	DDR	8	8	2 to 3PCLK*5
0008 C00Eh	PORTE	Data direction register	DDR	8	8	2 to 3PCLK*5
0008 C010h	PORTG	Data direction register	DDR*1*2*3	8	8	2 to 3PCLK*5
0008 C021h	PORT1	Data register	DR	8	8	2 to 3PCLK*5
0008 C022h	PORT2	Data register	DR	8	8	2 to 3PCLK*5
0008 C023h	PORT3	Data register	DR	8	8	2 to 3PCLK*5
0008 C027h	PORT7	Data register	DR	8	8	2 to 3PCLK*5
0008 C028h	PORT8	Data register	DR*2*3	8	8	2 to 3PCLK*5
0008 C029h	PORT9	Data register	DR	8	8	2 to 3PCLK*5
0008 C02Ah	PORTA	Data register	DR	8	8	2 to 3PCLK*5
0008 C02Bh	PORTB	Data register	DR	8	8	2 to 3PCLK*5
0008 C02Dh	PORTD	Data register	DR	8	8	2 to 3PCLK*5
0008 C02Eh	PORTE	Data register	DR	8	8	2 to 3PCLK*5
0008 C030h	PORTG	Data register	DR*1*2*3	8	8	2 to 3PCLK*5
0008 C041h	PORT1	Data register	PORT	8	8	2 to 3PCLK*5
0008 C042h	PORT2	Data register	PORT	8	8	2 to 3PCLK*5
0008 C043h	PORT3	Data register	PORT	8	8	2 to 3PCLK*5

**Table 4.1 List of I/O Registers (Address Order) (12 / 23)**

Address	Module Abbreviation	Register Name	Register Abbreviation	Number of Bits	Access Size	Number of Access Cycles
0008 C044h	PORT4	Data register	PORT	8	8	2 to 3PCLK*5
0008 C045h	PORT5	Data register	PORT*2*3	8	8	2 to 3PCLK*5
0008 C046h	PORT6	Data register	PORT*3	8	8	2 to 3PCLK*5
0008 C047h	PORT7	Data register	PORT	8	8	2 to 3PCLK*5
0008 C048h	PORT8	Data register	PORT*2*3	8	8	2 to 3PCLK*5
0008 C049h	PORT9	Data register	PORT	8	8	2 to 3PCLK*5
0008 C04Ah	PORTA	Data register	PORT	8	8	2 to 3PCLK*5
0008 C04Bh	PORTB	Data register	PORT	8	8	2 to 3PCLK*5
0008 C04Dh	PORTD	Data register	PORT	8	8	2 to 3PCLK*5
0008 C04Eh	PORTE	Data register	PORT	8	8	2 to 3PCLK*5
0008 C050h	PORTG	Port register	PORT*1*2*3	8	8	2 to 3PCLK*5
0008 C061h	PORT1	Input buffer control register	ICR	8	8	2 to 3PCLK*5
0008 C062h	PORT2	Input buffer control register	ICR	8	8	2 to 3PCLK*5
0008 C063h	PORT3	Input buffer control register	ICR	8	8	2 to 3PCLK*5
0008 C064h	PORT4	Input buffer control register	ICR	8	8	2 to 3PCLK*5
0008 C065h	PORT5	Input buffer control register	ICR*2*3	8	8	2 to 3PCLK*5
0008 C066h	PORT6	Input buffer control register	ICR*3	8	8	2 to 3PCLK*5
0008 C067h	PORT7	Input buffer control register	ICR	8	8	2 to 3PCLK*5
0008 C068h	PORT8	Input buffer control register	ICR*2*3	8	8	2 to 3PCLK*5
0008 C069h	PORT9	Input buffer control register	ICR	8	8	2 to 3PCLK*5
0008 C06Ah	PORTA	Input buffer control register	ICR	8	8	2 to 3PCLK*5
0008 C06Bh	PORTB	Input buffer control register	ICR	8	8	2 to 3PCLK*5
0008 C06Dh	PORTD	Input buffer control register	ICR	8	8	2 to 3PCLK*5
0008 C06Eh	PORTE	Input buffer control register	ICR	8	8	2 to 3PCLK*5
0008 C070h	PORTG	Input buffer control register	ICR*1*2*3	8	8	2 to 3PCLK*5
0008 C108h	IOPORT	Port function register 8	PF8IRQ	8	8	2 to 3PCLK*5
0008 C109h	IOPORT	Port function register 9	PF9IRQ	8	8	2 to 3PCLK*5
0008 C10Ah	IOPORT	Port function register A	PFAADC	8	8	2 to 3PCLK*5
0008 C10Ch	IOPORT	Port function register C	PFCMTU	8	8	2 to 3PCLK*5
0008 C10Dh	IOPORT	Port function register D	PFDGPT	8	8	2 to 3PCLK*5
0008 C10Fh	IOPORT	Port function register F	PFSCI	8	8	2 to 3PCLK*5
0008 C110h	IOPORT	Port function register G	PFGSPI	8	8	2 to 3PCLK*5
0008 C111h	IOPORT	Port function register H	PFHSPI	8	8	2 to 3PCLK*5
0008 C113h	IOPORT	Port function register J	PFJCAN	8	8	2 to 3PCLK*5
0008 C114h	IOPORT	Port function register K	PFKLIN	8	8	2 to 3PCLK*5
0008 C116h	IOPORT	Port function register M	PFMPOE	8	8	2 to 3PCLK*5
0008 C117h	IOPORT	Port function register N	PFNPOE	8	8	2 to 3PCLK*5
0008 C280h	SYSTEM	Deep standby control register	DPSBYCR	8	8	4 to 5PCLK*5
0008 C281h	SYSTEM	Deep standby wait control register	DPSWCR	8	8	4 to 5PCLK*5
0008 C282h	SYSTEM	Deep standby interrupt enable register	DPSIER	8	8	4 to 5PCLK*5
0008 C283h	SYSTEM	Deep standby interrupt flag register	DPSIFR	8	8	4 to 5PCLK*5
0008 C284h	SYSTEM	Deep standby interrupt edge register	DPSIEGR	8	8	4 to 5PCLK*5
0008 C285h	SYSTEM	Reset status register	RSTSR	8	8	4 to 5PCLK*5
0008 C289h	FLASH	Flash write erase protection register	FWEPOR	8	8	4 to 5PCLK*5

**Table 4.1 List of I/O Registers (Address Order) (13 / 23)**

Address	Module Abbreviation	Register Name	Register Abbreviation	Number of Bits	Access Size	Number of Access Cycles
0008 C28Ch	SYSTEM	Key code register for low-voltage detection control register	LVDKEYR	8	8	4 to 5PCLK*5
0008 C28Dh	SYSTEM	Voltage detection control register	LVDCR	8	8	4 to 5PCLK*5
0008 C290h	SYSTEM	Deep standby backup register 0	DPSBKR0	8	8	4 to 5PCLK*5
0008 C291h	SYSTEM	Deep standby backup register 1	DPSBKR1	8	8	4 to 5PCLK*5
0008 C292h	SYSTEM	Deep standby backup register 2	DPSBKR2	8	8	4 to 5PCLK*5
0008 C293h	SYSTEM	Deep standby backup register 3	DPSBKR3	8	8	4 to 5PCLK*5
0008 C294h	SYSTEM	Deep standby backup register 4	DPSBKR4	8	8	4 to 5PCLK*5
0008 C295h	SYSTEM	Deep standby backup register 5	DPSBKR5	8	8	4 to 5PCLK*5
0008 C296h	SYSTEM	Deep standby backup register 6	DPSBKR6	8	8	4 to 5PCLK*5
0008 C297h	SYSTEM	Deep standby backup register 7	DPSBKR7	8	8	4 to 5PCLK*5
0008 C298h	SYSTEM	Deep standby backup register 8	DPSBKR8	8	8	4 to 5PCLK*5
0008 C299h	SYSTEM	Deep standby backup register 9	DPSBKR9	8	8	4 to 5PCLK*5
0008 C29Ah	SYSTEM	Deep standby backup register 10	DPSBKR10	8	8	4 to 5PCLK*5
0008 C29Bh	SYSTEM	Deep standby backup register 11	DPSBKR11	8	8	4 to 5PCLK*5
0008 C29Ch	SYSTEM	Deep standby backup register 12	DPSBKR12	8	8	4 to 5PCLK*5
0008 C29Dh	SYSTEM	Deep standby backup register 13	DPSBKR13	8	8	4 to 5PCLK*5
0008 C29Eh	SYSTEM	Deep standby backup register 14	DPSBKR14	8	8	4 to 5PCLK*5
0008 C29Fh	SYSTEM	Deep standby backup register 15	DPSBKR15	8	8	4 to 5PCLK*5
0008 C2A0h	SYSTEM	Deep standby backup register 16	DPSBKR16	8	8	4 to 5PCLK*5
0008 C2A1h	SYSTEM	Deep standby backup register 17	DPSBKR17	8	8	4 to 5PCLK*5
0008 C2A2h	SYSTEM	Deep standby backup register 18	DPSBKR18	8	8	4 to 5PCLK*5
0008 C2A3h	SYSTEM	Deep standby backup register 19	DPSBKR19	8	8	4 to 5PCLK*5
0008 C2A4h	SYSTEM	Deep standby backup register 20	DPSBKR20	8	8	4 to 5PCLK*5
0008 C2A5h	SYSTEM	Deep standby backup register 21	DPSBKR21	8	8	4 to 5PCLK*5
0008 C2A6h	SYSTEM	Deep standby backup register 22	DPSBKR22	8	8	4 to 5PCLK*5
0008 C2A7h	SYSTEM	Deep standby backup register 23	DPSBKR23	8	8	4 to 5PCLK*5
0008 C2A8h	SYSTEM	Deep standby backup register 24	DPSBKR24	8	8	4 to 5PCLK*5
0008 C2A9h	SYSTEM	Deep standby backup register 25	DPSBKR25	8	8	4 to 5PCLK*5
0008 C2AAh	SYSTEM	Deep standby backup register 26	DPSBKR26	8	8	4 to 5PCLK*5
0008 C2ABh	SYSTEM	Deep standby backup register 27	DPSBKR27	8	8	4 to 5PCLK*5
0008 C2ACh	SYSTEM	Deep standby backup register 28	DPSBKR28	8	8	4 to 5PCLK*5
0008 C2ADh	SYSTEM	Deep standby backup register 29	DPSBKR29	8	8	4 to 5PCLK*5
0008 C2AEh	SYSTEM	Deep standby backup register 30	DPSBKR30	8	8	4 to 5PCLK*5
0008 C2AFh	SYSTEM	Deep standby backup register 31	DPSBKR31	8	8	4 to 5PCLK*5
0008 C4C0h	POE	Input level control/status register 1	ICSR1	16	8, 16	2 to 3PCLK*5
0008 C4C2h	POE	Output level control/status register 1	OCSR1	16	8, 16	2 to 3PCLK*5
0008 C4C4h	POE	Input level control/status register 2	ICSR2	16	8, 16	2 to 3PCLK*5
0008 C4C6h	POE	Output level control/status register 2	OCSR2	16	8, 16	2 to 3PCLK*5
0008 C4C8h	POE	Input level control/status register 3	ICSR3	16	8, 16	2 to 3PCLK*5
0008 C4CAh	POE	Software port output enable register	SPOER	8	8	2 to 3PCLK*5
0008 C4CBh	POE	Port output enable control register 1	POECR1	8	8	2 to 3PCLK*5
0008 C4CCh	POE	Port output enable control register 2	POECR2	16	16	2 to 3PCLK*5
0008 C4CEh	POE	Port output enable control register 3	POECR3	16	16	2 to 3PCLK*5

**Table 4.1 List of I/O Registers (Address Order) (14 / 23)**

Address	Module Abbreviation	Register Name	Register Abbreviation	Number of Bits	Access Size	Number of Access Cycles
0008 C4D0h	POE	Port output enable control register 4	POECR4	16	16	2 to 3PCLK*5
0008 C4D2h	POE	Port output enable control register 5	POECR5	16	16	2 to 3PCLK*5
0008 C4D4h	POE	Port output enable control register 6	POECR6	16	16	2 to 3PCLK*5
0008 C4D6h	POE	Input level control/status register 4	ICSR4	16	8, 16	2 to 3PCLK*5
0008 C4D8h	POE	Input level control/status register 5	ICSR5	16	8, 16	2 to 3PCLK*5
0008 C4DAh	POE	Active level setting register 1	ALR1	16	8, 16	2 to 3PCLK*5
0009 0200h to 0009 03FFh	CAN0*4	Mailbox registers 0 to 31	MB0 to MB 31	128	8, 16, 32	2 to 3PCLK*5
0009 0400h	CAN0*4	Mask register 0	MKR0	32	8, 16, 32	2 to 3PCLK*5
0009 0404h	CAN0*4	Mask register 1	MKR1	32	8, 16, 32	2 to 3PCLK*5
0009 0408h	CAN0*4	Mask register 2	MKR2	32	8, 16, 32	2 to 3PCLK*5
0009 040Ch	CAN0*4	Mask register 3	MKR3	32	8, 16, 32	2 to 3PCLK*5
0009 0410h	CAN0*4	Mask register 4	MKR4	32	8, 16, 32	2 to 3PCLK*5
0009 0414h	CAN0*4	Mask register 5	MKR5	32	8, 16, 32	2 to 3PCLK*5
0009 0418h	CAN0*4	Mask register 6	MKR6	32	8, 16, 32	2 to 3PCLK*5
0009 041Ch	CAN0*4	Mask register 7	MKR7	32	8, 16, 32	2 to 3PCLK*5
0009 0420h	CAN0*4	FIFO received ID compare register 0	FIDCR0	32	8, 16, 32	2 to 3PCLK*5
0009 0424h	CAN0*4	FIFO received ID compare register 1	FIDCR1	32	8, 16, 32	2 to 3PCLK*5
0009 0428h	CAN0*4	Mask invalid register	MKIVLR	32	8, 16, 32	2 to 3PCLK*5
0009 042Ch	CAN0*4	Mailbox interrupt enable register	MIER	32	8, 16, 32	2 to 3PCLK*5
0009 0820h to 0009 083Fh	CAN0*4	Message control registers 0 to 31	MCTL0 to MCTL31	8	8	2 to 3PCLK*5
0009 0840h	CAN0*4	Control register	CTLR	16	8, 16	2 to 3PCLK*5
0009 0842h	CAN0*4	Status register	STR	16	8, 16	2 to 3PCLK*5
0009 0844h	CAN0*4	Bit configuration register	BCR	32	8, 16, 32	2 to 3PCLK*5
0009 0848h	CAN0*4	Receive FIFO control register	RFCR	8	8	2 to 3PCLK*5
0009 0849h	CAN0*4	Receive FIFO pointer control register	RFPCR	8	8	2 to 3PCLK*5
0009 084Ah	CAN0*4	Transmit FIFO control register	TFCR	8	8	2 to 3PCLK*5
0009 084Bh	CAN0*4	Transmit FIFO pointer control register	TFPCR	8	8	2 to 3PCLK*5
0009 084Ch	CAN0*4	Error interrupt enable register	EIER	8	8	2 to 3PCLK*5
0009 084Dh	CAN0*4	Error interrupt factor judge register	EIFR	8	8	2 to 3PCLK*5
0009 084Eh	CAN0*4	Receive error count register	RECR	8	8	2 to 3PCLK*5
0009 084Fh	CAN0*4	Transmit error count register	TECR	8	8	2 to 3PCLK*5
0009 0850h	CAN0*4	Error code store register	ECSR	8	8	2 to 3PCLK*5
0009 0851h	CAN0*4	Channel search support register	CSSR	8	8	2 to 3PCLK*5
0009 0852h	CAN0*4	Mailbox search status register	MSSR	8	8	2 to 3PCLK*5
0009 0853h	CAN0*4	Mailbox search mode register	MSMR	8	8	2 to 3PCLK*5
0009 0854h	CAN0*4	Time stamp register	TSR	16	8, 16	2 to 3PCLK*5
0009 0856h	CAN0*4	Acceptance filter support register	AFSR	16	8, 16	2 to 3PCLK*5
0009 0858h	CAN0*4	Test control register	TCR	8	8	2 to 3PCLK*5
0009 4001h	LIN0	LIN wake-up baud rate select register	LWBR	8	8	2 to 3PCLK*5
0009 4002h	LIN0	LIN baud rate prescaler 0 register	LBRP0	8	8, 16	2 to 3PCLK*5
0009 4003h	LIN0	LIN baud rate prescaler 1 register	LBRP1	8	8, 16	2 to 3PCLK*5

**Table 4.1 List of I/O Registers (Address Order) (15 / 23)**

Address	Module Abbreviation	Register Name	Register Abbreviation	Number of Bits	Access Size	Number of Access Cycles
0009 4004h	LIN0	LIN self-test control register	LSTC	8	8	2 to 3PCLK*5
0009 4008h	LIN0	Mode register	L0MD	8	8, 16, 32	2 to 3PCLK*5
0009 4009h	LIN0	Break field setting register	L0BRK	8	8, 16, 32	2 to 3PCLK*5
0009 400Ah	LIN0	Space setting register	L0SPC	8	8, 16, 32	2 to 3PCLK*5
0009 400Bh	LIN0	Wake-up setting register	L0WUP	8	8, 16, 32	2 to 3PCLK*5
0009 400Ch	LIN0	Interrupt enable register	L0IE	8	8, 16	2 to 3PCLK*5
0009 400Dh	LIN0	Error detection enable register	L0EDE	8	8, 16	2 to 3PCLK*5
0009 400Eh	LIN0	Control register	L0C	8	8	2 to 3PCLK*5
0009 4010h	LIN0	Transmission control register	L0TC	8	8, 16, 32	2 to 3PCLK*5
0009 4011h	LIN0	Mode status register	L0MST	8	8, 16, 32	2 to 3PCLK*5
0009 4012h	LIN0	Status register	L0ST	8	8, 16, 32	2 to 3PCLK*5
0009 4013h	LIN0	Error status register	L0EST	8	8, 16, 32	2 to 3PCLK*5
0009 4014h	LIN0	Response field set register	L0RFC	8	8, 16	2 to 3PCLK*5
0009 4015h	LIN0	Buffer register	L0IDB	8	8, 16	2 to 3PCLK*5
0009 4016h	LIN0	Check sum buffer register	L0CBR	8	8	2 to 3PCLK*5
0009 4018h	LIN0	Data 1 buffer register	L0DB1	8	8, 16, 32	2 to 3PCLK*5
0009 4019h	LIN0	Data 2 buffer register	L0DB2	8	8, 16, 32	2 to 3PCLK*5
0009 401Ah	LIN0	Data 3 buffer register	L0DB3	8	8, 16, 32	2 to 3PCLK*5
0009 401Bh	LIN0	Data 4 buffer register	L0DB4	8	8, 16, 32	2 to 3PCLK*5
0009 401Ch	LIN0	Data 5 buffer register	L0DB5	8	8, 16, 32	2 to 3PCLK*5
0009 401Dh	LIN0	Data 6 buffer register	L0DB6	8	8, 16, 32	2 to 3PCLK*5
0009 401Eh	LIN0	Data 7 buffer register	L0DB7	8	8, 16, 32	2 to 3PCLK*5
0009 401Fh	LIN0	Data 8 buffer register	L0DB8	8	8, 16, 32	2 to 3PCLK*5
000C 1200h	MTU3	Timer control register	TCR	8	8, 16, 32	51CLK
000C 1201h	MTU4	Timer control register	TCR	8	8	51CLK
000C 1202h	MTU3	Timer mode register 1	TMDR1	8	8, 16	51CLK
000C 1203h	MTU4	Timer mode register 1	TMDR1	8	8	51CLK
000C 1204h	MTU3	Timer I/O control register H	TIORH	8	8, 16, 32	51CLK
000C 1205h	MTU3	Timer I/O control register L	TIORL	8	8	51CLK
000C 1206h	MTU4	Timer I/O control register H	TIORH	8	8, 16	51CLK
000C 1207h	MTU4	Timer I/O control register L	TIORL	8	8	51CLK
000C 1208h	MTU3	Timer interrupt enable register	TIER	8	8, 16	51CLK
000C 1209h	MTU4	Timer interrupt enable register	TIER	8	8	51CLK
000C 120Ah	MTU	Timer output master enable register A	TOERA	8	8	51CLK
000C 120Dh	MTU	Timer gate control register A	TGCRA	8	8	51CLK
000C 120Eh	MTU	Timer output control register 1A	TOCR1A	8	8, 16	51CLK
000C 120Fh	MTU	Timer output control register 2A	TOCR2A	8	8	51CLK
000C 1210h	MTU3	Timer counter	TCNT	16	16, 32	51CLK
000C 1212h	MTU4	Timer counter	TCNT	16	16	51CLK
000C 1214h	MTU	Timer cycle data register A	TCDRA	16	16, 32	51CLK
000C 1216h	MTU	Timer dead time data register A	TDDRA	16	16	51CLK
000C 1218h	MTU3	Timer general register A	TGRA	16	16, 32	51CLK
000C 121Ah	MTU3	Timer general register B	TGRB	16	16	51CLK
000C 121Ch	MTU4	Timer general register A	TGRA	16	16, 32	51CLK



**Table 4.1 List of I/O Registers (Address Order) (16 / 23)**

Address	Module Abbreviation	Register Name	Register Abbreviation	Number of Bits	Access Size	Number of Access Cycles
000C 121Eh	MTU4	Timer general register B	TGRB	16	16	5CLK
000C 1220h	MTU	Timer subcounter A	TCNTSA	16	16, 32	5CLK
000C 1222h	MTU	Timer cycle buffer register A	TCBRA	16	16	5CLK
000C 1224h	MTU3	Timer general register C	TGRC	16	16, 32	5CLK
000C 1226h	MTU3	Timer general register D	TGRD	16	16	5CLK
000C 1228h	MTU4	Timer general register C	TGRC	16	16, 32	5CLK
000C 122Ah	MTU4	Timer general register D	TGRD	16	16	5CLK
000C 122Ch	MTU3	Timer status register	TSR	8	8, 16	5CLK
000C 122Dh	MTU4	Timer status register	TSR	8	8	5CLK
000C 1230h	MTU	Timer interrupt skipping set register 1A	TITCR1A	8	8, 16	5CLK
000C 1231h	MTU	Timer interrupt skipping counter 1A	TITCNT1A	8	8	5CLK
000C 1232h	MTU	Timer buffer transfer set register A	TBTERA	8	8	5CLK
000C 1234h	MTU	Timer dead time enable register A	TDERA	8	8	5CLK
000C 1236h	MTU	Timer output level buffer register A	TOLBRA	8	8	5CLK
000C 1238h	MTU3	Timer buffer operation transfer mode register	TBTM	8	8, 16	5CLK
000C 1239h	MTU4	Timer buffer operation transfer mode register	TBTM	8	8	5CLK
000C 123Ah	MTU	Timer interrupt skipping mode register A	TITMRA	8	8	5CLK
000C 123Bh	MTU	Timer interrupt skipping set register 2A	TITCR2A	8	8	5CLK
000C 123Ch	MTU	Timer interrupt skipping counter 2A	TITCNT2A	8	8	5CLK
000C 1240h	MTU4	Timer A/D converter start request control register	TADCR	16	16	5CLK
000C 1244h	MTU4	Timer A/D converter start request cycle set register A	TADCORA	16	16, 32	5CLK
000C 1246h	MTU4	Timer A/D converter start request cycle set register B	TADCORB	16	16	5CLK
000C 1248h	MTU4	Timer A/D converter start request cycle set buffer register A	TADCOBRA	16	16, 32	5CLK
000C 124Ah	MTU4	Timer A/D converter start request cycle set buffer register B	TADCOBRB	16	16	5CLK
000C 1260h	MTU	Timer waveform control register A	TWCRA	8	8	5CLK
000C 1270h	MTU3	Timer mode register 2A	TMDR2A	8	8	5CLK
000C 1272h	MTU3	Timer general register E	TGRE	16	16	5CLK
000C 1274h	MTU4	Timer general register E	TGRE	16	16	5CLK
000C 1276h	MTU4	Timer general register F	TGRF	16	16	5CLK
000C 1280h	MTU	Timer start register A	TSTRA	8	8, 16	5CLK
000C 1281h	MTU	Timer synchronous register A	TSYRA	8	8	5CLK
000C 1282h	MTU	Timer counter synchronous start register	TCSYSTR	8	8	5CLK
000C 1284h	MTU	Timer read/write enable register A	TRWERA	8	8	5CLK
000C 1300h	MTU0	Timer control register	TCR	8	8, 16, 32	5CLK
000C 1301h	MTU0	Timer mode register 1	TMDR1	8	8	5CLK
000C 1302h	MTU0	Timer I/O control register H	TIORH	8	8, 16	5CLK
000C 1303h	MTU0	Timer I/O control register L	TIORL	8	8	5CLK
000C 1304h	MTU0	Timer interrupt enable register	TIER	8	8, 16, 32	5CLK
000C 1305h	MTU0	Timer status register	TSR	8	8	5CLK
000C 1306h	MTU0	Timer counter	TCNT	16	16	5CLK
000C 1308h	MTU0	Timer general register A	TGRA	16	16, 32	5CLK

**Table 4.1 List of I/O Registers (Address Order) (17 / 23)**

Address	Module Abbreviation	Register Name	Register Abbreviation	Number of Bits	Access Size	Number of Access Cycles
000C 130Ah	MTU0	Timer general register B	TGRB	16	16	5CLK
000C 130Ch	MTU0	Timer general register C	TGRC	16	16, 32	5CLK
000C 130Eh	MTU0	Timer general register D	TGRD	16	16	5CLK
000C 1320h	MTU0	Timer general register E	TGRE	16	16, 32	5CLK
000C 1322h	MTU0	Timer general register F	TGRF	16	16	5CLK
000C 1324h	MTU0	Timer interrupt enable register 2	TIER2	8	8, 16	5CLK
000C 1325h	MTU0	Timer status register 2	TSR2	8	8	5CLK
000C 1326h	MTU0	Timer buffer operation transfer mode register	TBTM	8	8	5CLK
000C 1380h	MTU1	Timer control register	TCR	8	8, 16	5CLK
000C 1381h	MTU1	Timer mode register 1	TMDR1	8	8	5CLK
000C 1382h	MTU1	Timer I/O control register	TIOR	8	8	5CLK
000C 1384h	MTU1	Timer interrupt enable register	TIER	8	8, 16, 32	5CLK
000C 1385h	MTU1	Timer status register	TSR	8	8	5CLK
000C 1386h	MTU1	Timer counter	TCNT	16	16	5CLK
000C 1388h	MTU1	Timer general register A	TGRA	16	16, 32	5CLK
000C 138Ah	MTU1	Timer general register B	TGRB	16	16	5CLK
000C 1390h	MTU1	Timer input capture control register	TICCR	8	8	5CLK
000C 1400h	MTU2	Timer control register	TCR	8	8, 16	5CLK
000C 1401h	MTU2	Timer mode register 1	TMDR1	8	8	5CLK
000C 1402h	MTU2	Timer I/O control register	TIOR	8	8	5CLK
000C 1404h	MTU2	Timer interrupt enable register	TIER	8	8, 16, 32	5CLK
000C 1405h	MTU2	Timer status register	TSR	8	8	5CLK
000C 1406h	MTU2	Timer counter	TCNT	16	16	5CLK
000C 1408h	MTU2	Timer general register A	TGRA	16	16, 32	5CLK
000C 140Ah	MTU2	Timer general register B	TGRB	16	16	5CLK
000C 1A00h	MTU6	Timer control register	TCR	8	8, 16, 32	5CLK
000C 1A01h	MTU7	Timer control register	TCR	8	8	5CLK
000C 1A02h	MTU6	Timer mode register 1	TMDR1	8	8, 16	5CLK
000C 1A03h	MTU7	Timer mode register 1	TMDR1	8	8	5CLK
000C 1A04h	MTU6	Timer I/O control register H	TIORH	8	8, 16, 32	5CLK
000C 1A05h	MTU6	Timer I/O control register L	TIORL	8	8	5CLK
000C 1A06h	MTU7	Timer I/O control register H	TIORH	8	8, 16	5CLK
000C 1A07h	MTU7	Timer I/O control register L	TIORL	8	8	5CLK
000C 1A08h	MTU6	Timer interrupt enable register	TIER	8	8, 16	5CLK
000C 1A09h	MTU7	Timer interrupt enable register	TIER	8	8	5CLK
000C 1A0Ah	MTU	Timer output master enable register B	TOERB	8	8	5CLK
000C 1A0Eh	MTU	Timer output control register 1B	TOCR1B	8	8, 16	5CLK
000C 1A0Fh	MTU	Timer output control register 2B	TOCR2B	8	8	5CLK
000C 1A10h	MTU6	Timer counter	TCNT	16	16, 32	5CLK
000C 1A12h	MTU7	Timer counter	TCNT	16	16	5CLK
000C 1A14h	MTU	Timer cycle data register B	TCDRB	16	16, 32	5CLK
000C 1A16h	MTU	Timer dead time data register B	TDDRb	16	16	5CLK
000C 1A18h	MTU6	Timer general register A	TGRA	16	16, 32	5CLK
000C 1A1Ah	MTU6	Timer general register B	TGRB	16	16	5CLK

**Table 4.1 List of I/O Registers (Address Order) (18 / 23)**

Address	Module Abbreviation	Register Name	Register Abbreviation	Number of Bits	Access Size	Number of Access Cycles
000C 1A1Ch	MTU7	Timer general register A	TGRA	16	16, 32	5CLK
000C 1A1Eh	MTU7	Timer general register B	TGRB	16	16	5CLK
000C 1A20h	MTU	Timer subcounter B	TCNTSB	16	16, 32	5CLK
000C 1A22h	MTU	Timer cycle buffer register B	TCBRB	16	16	5CLK
000C 1A24h	MTU6	Timer general register C	TGRC	16	16, 32	5CLK
000C 1A26h	MTU6	Timer general register D	TGRD	16	16	5CLK
000C 1A28h	MTU7	Timer general register C	TGRC	16	16, 32	5CLK
000C 1A2Ah	MTU7	Timer general register D	TGRD	16	16	5CLK
000C 1A2Ch	MTU6	Timer status register	TSR	8	8, 16	5CLK
000C 1A2Dh	MTU7	Timer status register	TSR	8	8	5CLK
000C 1A30h	MTU	Timer interrupt skipping set register 1B	TITCR1B	8	8, 16	5CLK
000C 1A31h	MTU	Timer interrupt skipping counter 1B	TITCNT1B	8	8	5CLK
000C 1A32h	MTU	Timer buffer transfer set register B	TBTERB	8	8	5CLK
000C 1A34h	MTU	Timer dead time enable register B	TDERB	8	8	5CLK
000C 1A36h	MTU	Timer output level buffer register B	TOLBRB	8	8	5CLK
000C 1A38h	MTU6	Timer buffer operation transfer mode register	TBTM	8	8, 16	5CLK
000C 1A39h	MTU7	Timer buffer operation transfer mode register	TBTM	8	8	5CLK
000C 1A3Ah	MTU	Timer interrupt skipping mode register B	TITMRB	8	8	5CLK
000C 1A3Bh	MTU	Timer interrupt skipping set register 2B	TITCR2B	8	8	5CLK
000C 1A3Ch	MTU	Timer interrupt skipping counter 2B	TITCNT2B	8	8	5CLK
000C 1A40h	MTU7	Timer A/D converter start request control register	TADCR	16	16	5CLK
000C 1A44h	MTU7	Timer A/D converter start request cycle set register A	TADCORA	16	16, 32	5CLK
000C 1A46h	MTU7	Timer A/D converter start request cycle set register B	TADCORB	16	16	5CLK
000C 1A48h	MTU7	Timer A/D converter start request cycle set buffer register A	TADCOBRA	16	16, 32	5CLK
000C 1A4Ah	MTU7	Timer A/D converter start request cycle set buffer register B	TADCOBRB	16	16	5CLK
000C 1A50h	MTU6	Timer synchronous clear register	TSYCR	8	8	5CLK
000C 1A60h	MTU	Timer waveform control register B	TWCRB	8	8	5CLK
000C 1A70h	MTU	Timer mode register 2B	TMDR2B	8	8	5CLK
000C 1A72h	MTU6	Timer general register E	TGRE	16	16	5CLK
000C 1A74h	MTU7	Timer general register E	TGRE	16	16	5CLK
000C 1A76h	MTU7	Timer general register F	TGRF	16	16	5CLK
000C 1A80h	MTU	Timer start register B	TSTRB	8	8, 16	5CLK
000C 1A81h	MTU	Timer synchronous register B	TSYRB	8	8	5CLK
000C 1A84h	MTU	Timer read/write enable register B	TRWERB	8	8	5CLK
000C 1C80h	MTU5	Timer counter U	TCNTU	16	16, 32	5CLK
000C 1C82h	MTU5	Timer general register U	TGRU	16	16	5CLK
000C 1C84h	MTU5	Timer control register U	TCRU	8	8	5CLK
000C 1C86h	MTU5	Timer I/O control register U	TIORU	8	8	5CLK
000C 1C90h	MTU5	Timer counter V	TCNTV	16	16, 32	5CLK
000C 1C92h	MTU5	Timer general register V	TGRV	16	16	5CLK
000C 1C94h	MTU5	Timer control register V	TCRV	8	8	5CLK

**Table 4.1 List of I/O Registers (Address Order) (19 / 23)**

Address	Module Abbreviation	Register Name	Register Abbreviation	Number of Bits	Access Size	Number of Access Cycles
000C 1C96h	MTU5	Timer I/O control register V	TIORV	8	8	51CLK
000C 1CA0h	MTU5	Timer counter W	TCNTW	16	16, 32	51CLK
000C 1CA2h	MTU5	Timer general register W	TGRW	16	16	51CLK
000C 1CA4h	MTU5	Timer control register W	TCRW	8	8	51CLK
000C 1CA6h	MTU5	Timer I/O control register W	TIORW	8	8	51CLK
000C 1CB0h	MTU5	Timer status register	TSR	8	8	51CLK
000C 1CB2h	MTU5	Timer interrupt enable register	TIER	8	8	51CLK
000C 1CB4h	MTU5	Timer start register	TSTR	8	8	51CLK
000C 1CB6h	MTU5	Timer compare match clear register	TCNTCMPC LR	8	8	51CLK
000C 2000h	GPT	General PWM timer software start register	GTSTR	16	8, 16, 32	3 to 51CLK <sup>*6</sup>
000C 2004h	GPT	General PWM timer hardware source start control register	GTHSCR	16	8, 16, 32	3 to 51CLK <sup>*6</sup>
000C 2006h	GPT	General PWM timer hardware source clear control register	GTHCCR	16	8, 16, 32	3 to 51CLK <sup>*6</sup>
000C 2008h	GPT	General PWM timer hardware start source select register	GTHSSR	16	8, 16, 32	3 to 51CLK <sup>*6</sup>
000C 200Ah	GPT	General PWM timer hardware stop/clear source select register	GTHPSR	16	8, 16, 32	3 to 51CLK <sup>*6</sup>
000C 200Ch	GPT	General PWM timer write-protection register	GTWP	16	8, 16, 32	3 to 51CLK <sup>*6</sup>
000C 200Eh	GPT	General PWM timer sync register	GTSYNC	16	8, 16, 32	3 to 51CLK <sup>*6</sup>
000C 2010h	GPT	General PWM timer external trigger input interrupt register	GTETINT	16	8, 16, 32	3 to 51CLK <sup>*6</sup>
000C 2014h	GPT	General PWM timer buffer operation disable register	GTBDR	16	8, 16, 32	3 to 51CLK <sup>*6</sup>
000C 2080h	GPT	LOCO count control register	LCCR	16	8, 16, 32	3 to 51CLK <sup>*6</sup>
000C 2082h	GPT	LOCO count status register	LCST	16	8, 16, 32	3 to 51CLK <sup>*6</sup>
000C 2084h	GPT	LOCO count value register	LCNT	16	8, 16, 32	3 to 51CLK <sup>*6</sup>
000C 2086h	GPT	LOCO count result average register	LCNTA	16	8, 16, 32	3 to 51CLK <sup>*6</sup>
000C 2088h	GPT	LOCO count result register 0	LCNT00	16	8, 16, 32	3 to 51CLK <sup>*6</sup>
000C 208Ah	GPT	LOCO count result register 1	LCNT01	16	8, 16, 32	3 to 51CLK <sup>*6</sup>
000C 208Ch	GPT	LOCO count result register 2	LCNT02	16	8, 16, 32	3 to 51CLK <sup>*6</sup>
000C 208Eh	GPT	LOCO count result register 3	LCNT03	16	8, 16, 32	3 to 51CLK <sup>*6</sup>
000C 2090h	GPT	LOCO count result register 4	LCNT04	16	8, 16, 32	3 to 51CLK <sup>*6</sup>
000C 2092h	GPT	LOCO count result register 5	LCNT05	16	8, 16, 32	3 to 51CLK <sup>*6</sup>
000C 2094h	GPT	LOCO count result register 6	LCNT06	16	8, 16, 32	3 to 51CLK <sup>*6</sup>
000C 2096h	GPT	LOCO count result register 7	LCNT07	16	8, 16, 32	3 to 51CLK <sup>*6</sup>
000C 2098h	GPT	LOCO count result register 8	LCNT08	16	8, 16, 32	3 to 51CLK <sup>*6</sup>
000C 209Ah	GPT	LOCO count result register 9	LCNT09	16	8, 16, 32	3 to 51CLK <sup>*6</sup>
000C 209Ch	GPT	LOCO count result register 10	LCNT10	16	8, 16, 32	3 to 51CLK <sup>*6</sup>
000C 209Eh	GPT	LOCO count result register 11	LCNT11	16	8, 16, 32	3 to 51CLK <sup>*6</sup>
000C 20A0h	GPT	LOCO count result register 12	LCNT12	16	8, 16, 32	3 to 51CLK <sup>*6</sup>
000C 20A2h	GPT	LOCO count result register 13	LCNT13	16	8, 16, 32	3 to 51CLK <sup>*6</sup>
000C 20A4h	GPT	LOCO count result register 14	LCNT14	16	8, 16, 32	3 to 51CLK <sup>*6</sup>
000C 20A6h	GPT	LOCO count result register 15	LCNT15	16	8, 16, 32	3 to 51CLK <sup>*6</sup>
000C 20A8h	GPT	LOCO count upper permissible deviation register	LCNTDU	16	8, 16, 32	3 to 51CLK <sup>*6</sup>

**Table 4.1 List of I/O Registers (Address Order) (20 / 23)**

Address	Module Abbreviation	Register Name	Register Abbreviation	Number of Bits	Access Size	Number of Access Cycles
000C 20AAh	GPT	LOCO count lower permissible deviation register	LCNTDL	16	8, 16, 32	3 to 5ICLK <sup>*6</sup>
000C 2100h	GPT0	General PWM timer I/O control register	GTIOR	16	8, 16, 32	3 to 5ICLK <sup>*6</sup>
000C 2102h	GPT0	General PWM timer interrupt output setting register	GTINTAD	16	8, 16, 32	3 to 5ICLK <sup>*6</sup>
000C 2104h	GPT0	General PWM timer control register	GTCR	16	8, 16, 32	3 to 5ICLK <sup>*6</sup>
000C 2106h	GPT0	General PWM timer buffer enable register	GTBER	16	8, 16, 32	3 to 5ICLK <sup>*6</sup>
000C 2108h	GPT0	General PWM timer count direction register	GTUDC	16	8, 16, 32	3 to 5ICLK <sup>*6</sup>
000C 210Ah	GPT0	General PWM timer interrupt and A/D converter start request skipping setting register	GTITC	16	8, 16, 32	3 to 5ICLK <sup>*6</sup>
000C 210Ch	GPT0	General PWM timer status register	GTST	16	8, 16, 32	3 to 5ICLK <sup>*6</sup>
000C 210Eh	GPT0	General PWM timer counter	GTCNT	16	16	3 to 5ICLK <sup>*6</sup>
000C 2110h	GPT0	General PWM timer compare capture register A	GTCCRA	16	16, 32	3 to 5ICLK <sup>*6</sup>
000C 2112h	GPT0	General PWM timer compare capture register B	GTCCRB	16	16, 32	3 to 5ICLK <sup>*6</sup>
000C 2114h	GPT0	General PWM timer compare capture register C	GTCCRC	16	16, 32	3 to 5ICLK <sup>*6</sup>
000C 2116h	GPT0	General PWM timer compare capture register D	GTCCRD	16	16, 32	3 to 5ICLK <sup>*6</sup>
000C 2118h	GPT0	General PWM timer compare capture register E	GTCCRE	16	16, 32	3 to 5ICLK <sup>*6</sup>
000C 211Ah	GPT0	General PWM timer compare capture register F	GTCCRF	16	16, 32	3 to 5ICLK <sup>*6</sup>
000C 211Ch	GPT0	General PWM timer cycle setting register	GTPR	16	16, 32	3 to 5ICLK <sup>*6</sup>
000C 211Eh	GPT0	General PWM timer cycle setting buffer register	GTPBR	16	16, 32	3 to 5ICLK <sup>*6</sup>
000C 2120h	GPT0	General PWM timer cycle setting double-buffer register	GTPDBR	16	16, 32	3 to 5ICLK <sup>*6</sup>
000C 2124h	GPT0	A/D converter start request timing register A	GTADTRA	16	16, 32	3 to 5ICLK <sup>*6</sup>
000C 2126h	GPT0	A/D converter start request timing buffer register A	GTADTBRA	16	16, 32	3 to 5ICLK <sup>*6</sup>
000C 2128h	GPT0	A/D converter start request timing double-buffer register A	GTADTBRA	16	16, 32	3 to 5ICLK <sup>*6</sup>
000C 212Ch	GPT0	A/D converter start request timing register B	GTADTRB	16	16, 32	3 to 5ICLK <sup>*6</sup>
000C 212Eh	GPT0	A/D converter start request timing buffer register B	GTADTBRA	16	16, 32	3 to 5ICLK <sup>*6</sup>
000C 2130h	GPT0	A/D converter start request timing double-buffer register B	GTADTBRA	16	16, 32	3 to 5ICLK <sup>*6</sup>
000C 2134h	GPT0	General PWM timer output negate control register	GTONCR	16	16, 32	3 to 5ICLK <sup>*6</sup>
000C 2136h	GPT0	General PWM timer dead time control register	GTDTCR	16	16, 32	3 to 5ICLK <sup>*6</sup>
000C 2138h	GPT0	General PWM timer dead time value register	GTDVU	16	16, 32	3 to 5ICLK <sup>*6</sup>
000C 213Ah	GPT0	General PWM timer dead time value register	GTDVD	16	16, 32	3 to 5ICLK <sup>*6</sup>
000C 213Ch	GPT0	General PWM timer dead time buffer register	GTDBU	16	16, 32	3 to 5ICLK <sup>*6</sup>
000C 213Eh	GPT0	General PWM timer dead time buffer register	GTDBD	16	16, 32	3 to 5ICLK <sup>*6</sup>
000C 2140h	GPT0	General PWM timer output protection function status register	GTSOS	16	16, 32	3 to 5ICLK <sup>*6</sup>
000C 2142h	GPT0	General PWM timer output protection function temporary release register	GTSOTR	16	16, 32	3 to 5ICLK <sup>*6</sup>
000C 2180h	GPT1	General PWM timer I/O control register	GTIOR	16	8, 16, 32	3 to 5ICLK <sup>*6</sup>
000C 2182h	GPT1	General PWM timer interrupt output setting register	GTINTAD	16	8, 16, 32	3 to 5ICLK <sup>*6</sup>
000C 2184h	GPT1	General PWM timer control register	GTCR	16	8, 16, 32	3 to 5ICLK <sup>*6</sup>
000C 2186h	GPT1	General PWM timer buffer enable register	GTBER	16	8, 16, 32	3 to 5ICLK <sup>*6</sup>

**Table 4.1 List of I/O Registers (Address Order) (21 / 23)**

Address	Module Abbreviation	Register Name	Register Abbreviation	Number of Bits	Access Size	Number of Access Cycles
000C 2188h	GPT1	General PWM timer count direction register	GTUDC	16	8, 16, 32	3 to 5ICLK <sup>*6</sup>
000C 218Ah	GPT1	General PWM timer interrupt and A/D converter start request skipping setting register	GTITC	16	8, 16, 32	3 to 5ICLK <sup>*6</sup>
000C 218Ch	GPT1	General PWM timer status register	GTST	16	8, 16, 32	3 to 5ICLK <sup>*6</sup>
000C 218Eh	GPT1	General PWM timer counter	GTCNT	16	16	3 to 5ICLK <sup>*6</sup>
000C 2190h	GPT1	General PWM timer compare capture register A	GTCCRA	16	16, 32	3 to 5ICLK <sup>*6</sup>
000C 2192h	GPT1	General PWM timer compare capture register B	GTCCRB	16	16, 32	3 to 5ICLK <sup>*6</sup>
000C 2194h	GPT1	General PWM timer compare capture register C	GTCCRC	16	16, 32	3 to 5ICLK <sup>*6</sup>
000C 2196h	GPT1	General PWM timer compare capture register D	GTCCRD	16	16, 32	3 to 5ICLK <sup>*6</sup>
000C 2198h	GPT1	General PWM timer compare capture register E	GTCCRE	16	16, 32	3 to 5ICLK <sup>*6</sup>
000C 219Ah	GPT1	General PWM timer compare capture register F	GTCCRF	16	16, 32	3 to 5ICLK <sup>*6</sup>
000C 219Ch	GPT1	General PWM timer cycle setting register	GTPR	16	16, 32	3 to 5ICLK <sup>*6</sup>
000C 219Eh	GPT1	General PWM timer cycle setting buffer register	GTPBR	16	16, 32	3 to 5ICLK <sup>*6</sup>
000C 21A0h	GPT1	General PWM timer cycle setting double-buffer register	GTPDBR	16	16, 32	3 to 5ICLK <sup>*6</sup>
000C 21A4h	GPT1	A/D converter start request timing register A	GTADTRA	16	16, 32	3 to 5ICLK <sup>*6</sup>
000C 21A6h	GPT1	A/D converter start request timing buffer register A	GTADTBRA	16	16, 32	3 to 5ICLK <sup>*6</sup>
000C 21A8h	GPT1	A/D converter start request timing double-buffer register A	GTADTBRA	16	16, 32	3 to 5ICLK <sup>*6</sup>
000C 21ACh	GPT1	A/D converter start request timing register B	GTADTRB	16	16, 32	3 to 5ICLK <sup>*6</sup>
000C 21AEh	GPT1	A/D converter start request timing buffer register B	GTADTRB	16	16, 32	3 to 5ICLK <sup>*6</sup>
000C 21B0h	GPT1	A/D converter start request timing double-buffer register B	GTADTRB	16	16, 32	3 to 5ICLK <sup>*6</sup>
000C 21B4h	GPT1	General PWM timer output negate control register	GTONCR	16	16, 32	3 to 5ICLK <sup>*6</sup>
000C 21B6h	GPT1	General PWM timer dead time control register	GTDTCR	16	16, 32	3 to 5ICLK <sup>*6</sup>
000C 21B8h	GPT1	General PWM timer dead time value register	GTDVU	16	16, 32	3 to 5ICLK <sup>*6</sup>
000C 21BAh	GPT1	General PWM timer dead time value register	GTDVD	16	16, 32	3 to 5ICLK <sup>*6</sup>
000C 21BCh	GPT1	General PWM timer dead time buffer register	GTDBU	16	16, 32	3 to 5ICLK <sup>*6</sup>
000C 21BEh	GPT1	General PWM timer dead time buffer register	GTDBD	16	16, 32	3 to 5ICLK <sup>*6</sup>
000C 21C0h	GPT1	General PWM timer output protection function status register	GTSOS	16	16, 32	3 to 5ICLK <sup>*6</sup>
000C 21C2h	GPT1	General PWM timer output protection temporary release register	GTSOTR	16	16, 32	3 to 5ICLK <sup>*6</sup>
000C 2200h	GPT2	General PWM timer I/O control register	GTIOR	16	8, 16, 32	3 to 5ICLK <sup>*6</sup>
000C 2202h	GPT2	General PWM timer interrupt output setting register	GTINTAD	16	8, 16, 32	3 to 5ICLK <sup>*6</sup>
000C 2204h	GPT2	General PWM timer control register	GTCR	16	8, 16, 32	3 to 5ICLK <sup>*6</sup>
000C 2206h	GPT2	General PWM timer buffer enable register	GTBER	16	8, 16, 32	3 to 5ICLK <sup>*6</sup>
000C 2208h	GPT2	General PWM timer count direction register	GTUDC	16	8, 16, 32	3 to 5ICLK <sup>*6</sup>
000C 220Ah	GPT2	General PWM timer interrupt and A/D converter start request skipping setting register	GTITC	16	8, 16, 32	3 to 5ICLK <sup>*6</sup>
000C 220Ch	GPT2	General PWM timer status register	GTST	16	8, 16, 32	3 to 5ICLK <sup>*6</sup>
000C 220Eh	GPT2	General PWM timer counter	GTCNT	16	16	3 to 5ICLK <sup>*6</sup>
000C 2210h	GPT2	General PWM timer compare capture register A	GTCCRA	16	16, 32	3 to 5ICLK <sup>*6</sup>

**Table 4.1 List of I/O Registers (Address Order) (22 / 23)**

Address	Module Abbreviation	Register Name	Register Abbreviation	Number of Bits	Access Size	Number of Access Cycles
000C 2212h	GPT2	General PWM timer compare capture register B	GTCCRB	16	16, 32	3 to 51CLK <sup>*6</sup>
000C 2214h	GPT2	General PWM timer compare capture register C	GTCCRC	16	16, 32	3 to 51CLK <sup>*6</sup>
000C 2216h	GPT2	General PWM timer compare capture register D	GTCCRD	16	16, 32	3 to 51CLK <sup>*6</sup>
000C 2218h	GPT2	General PWM timer compare capture register E	GTCCRE	16	16, 32	3 to 51CLK <sup>*6</sup>
000C 221Ah	GPT2	General PWM timer compare capture register F	GTCCRF	16	16, 32	3 to 51CLK <sup>*6</sup>
000C 221Ch	GPT2	General PWM timer cycle setting register	GTPR	16	16, 32	3 to 51CLK <sup>*6</sup>
000C 221Eh	GPT2	General PWM timer cycle setting buffer register	GTPBR	16	16, 32	3 to 51CLK <sup>*6</sup>
000C 2220h	GPT2	General PWM timer cycle setting double-buffer register	GTPDBR	16	16, 32	3 to 51CLK <sup>*6</sup>
000C 2224h	GPT2	A/D converter start request timing register A	GTADTRA	16	16, 32	3 to 51CLK <sup>*6</sup>
000C 2226h	GPT2	A/D converter start request timing buffer register A	GTADTBRA	16	16, 32	3 to 51CLK <sup>*6</sup>
000C 2228h	GPT2	A/D converter start request timing double-buffer register A	GTADTBRA	16	16, 32	3 to 51CLK <sup>*6</sup>
000C 222Ch	GPT2	A/D converter start request timing register B	GTADTRB	16	16, 32	3 to 51CLK <sup>*6</sup>
000C 222Eh	GPT2	A/D converter start request timing buffer register B	GTADTRB	16	16, 32	3 to 51CLK <sup>*6</sup>
000C 2230h	GPT2	A/D converter start request timing double-buffer register B	GTADTRB	16	16, 32	3 to 51CLK <sup>*6</sup>
000C 2234h	GPT2	General PWM timer output negate control register	GTONCR	16	16, 32	3 to 51CLK <sup>*6</sup>
000C 2236h	GPT2	General PWM timer dead time control register	GTDTCR	16	16, 32	3 to 51CLK <sup>*6</sup>
000C 2238h	GPT2	General PWM timer dead time value register	GTDVU	16	16, 32	3 to 51CLK <sup>*6</sup>
000C 223Ah	GPT2	General PWM timer dead time value register	GTDVD	16	16, 32	3 to 51CLK <sup>*6</sup>
000C 223Ch	GPT2	General PWM timer dead time buffer register	GTDBU	16	16, 32	3 to 51CLK <sup>*6</sup>
000C 223Eh	GPT2	General PWM timer dead time buffer register	GTDBD	16	16, 32	3 to 51CLK <sup>*6</sup>
000C 2240h	GPT2	General PWM timer output protection function status register	GTSOS	16	16, 32	3 to 51CLK <sup>*6</sup>
000C 2242h	GPT2	General PWM timer output protection temporary release register	GTSOTR	16	16, 32	3 to 51CLK <sup>*6</sup>
000C 2280h	GPT3	General PWM timer I/O control register	GTIOR	16	8, 16, 32	3 to 51CLK <sup>*6</sup>
000C 2282h	GPT3	General PWM timer interrupt output setting register	GTINTAD	16	8, 16, 32	3 to 51CLK <sup>*6</sup>
000C 2284h	GPT3	General PWM timer control register	GTCR	16	8, 16, 32	3 to 51CLK <sup>*6</sup>
000C 2286h	GPT3	General PWM timer buffer enable register	GTBER	16	8, 16, 32	3 to 51CLK <sup>*6</sup>
000C 2288h	GPT3	General PWM timer count direction register	GTUDC	16	8, 16, 32	3 to 51CLK <sup>*6</sup>
000C 228Ah	GPT3	General PWM timer interrupt and A/D converter start request skipping setting register	GTITC	16	8, 16, 32	3 to 51CLK <sup>*6</sup>
000C 228Ch	GPT3	General PWM timer status register	GTST	16	8, 16, 32	3 to 51CLK <sup>*6</sup>
000C 228Eh	GPT3	General PWM timer counter	GTCNT	16	16	3 to 51CLK <sup>*6</sup>
000C 2290h	GPT3	General PWM timer compare capture register A	GTCCRA	16	16, 32	3 to 51CLK <sup>*6</sup>
000C 2292h	GPT3	General PWM timer compare capture register B	GTCCRB	16	16, 32	3 to 51CLK <sup>*6</sup>
000C 2294h	GPT3	General PWM timer compare capture register C	GTCCRC	16	16, 32	3 to 51CLK <sup>*6</sup>
000C 2296h	GPT3	General PWM timer compare capture register D	GTCCRD	16	16, 32	3 to 51CLK <sup>*6</sup>
000C 2298h	GPT3	General PWM timer compare capture register E	GTCCRE	16	16, 32	3 to 51CLK <sup>*6</sup>
000C 229Ah	GPT3	General PWM timer compare capture register F	GTCCRF	16	16, 32	3 to 51CLK <sup>*6</sup>
000C 229Ch	GPT3	General PWM timer cycle setting register	GTPR	16	16, 32	3 to 51CLK <sup>*6</sup>

**Table 4.1 List of I/O Registers (Address Order) (23 / 23)**

Address	Module Abbreviation	Register Name	Register Abbreviation	Number of Bits	Access Size	Number of Access Cycles
000C 229Eh	GPT3	General PWM timer cycle setting buffer register	GTPBR	16	16, 32	3 to 51CLK <sup>*6</sup>
000C 22A0h	GPT3	General PWM timer cycle setting double-buffer register	GTPDBR	16	16, 32	3 to 51CLK <sup>*6</sup>
000C 22A4h	GPT3	A/D converter start request timing register A	GTADTRA	16	16, 32	3 to 51CLK <sup>*6</sup>
000C 22A6h	GPT3	A/D converter start request timing buffer register A	GTADTBRA	16	16, 32	3 to 51CLK <sup>*6</sup>
000C 22A8h	GPT3	A/D converter start request timing double-buffer register A	GTADTDBRA	16	16, 32	3 to 51CLK <sup>*6</sup>
000C 22ACh	GPT3	A/D converter start request timing register B	GTADTRB	16	16, 32	3 to 51CLK <sup>*6</sup>
000C 22AEh	GPT3	A/D converter start request timing buffer register B	GTADTRB	16	16, 32	3 to 51CLK <sup>*6</sup>
000C 22B0h	GPT3	A/D converter start request timing double-buffer register B	GTADTDBRB	16	16, 32	3 to 51CLK <sup>*6</sup>
000C 22B4h	GPT3	General PWM timer output negate control register	GTONCR	16	16, 32	3 to 51CLK <sup>*6</sup>
000C 22B6h	GPT3	General PWM timer dead time control register	GTDTCR	16	16, 32	3 to 51CLK <sup>*6</sup>
000C 22B8h	GPT3	General PWM timer dead time value register	GTDVU	16	16, 32	3 to 51CLK <sup>*6</sup>
000C 22BAh	GPT3	General PWM timer dead time value register	GTDVD	16	16, 32	3 to 51CLK <sup>*6</sup>
000C 22BCh	GPT3	General PWM timer dead time buffer register	GTDBU	16	16, 32	3 to 51CLK <sup>*6</sup>
000C 22BEh	GPT3	General PWM timer dead time buffer register	GTDBD	16	16, 32	3 to 51CLK <sup>*6</sup>
000C 22C0h	GPT3	General PWM timer output protection function status register	GTSOS	16	16, 32	3 to 51CLK <sup>*6</sup>
000C 22C2h	GPT3	General PWM timer output protection temporary release register	GTSOTR	16	16, 32	3 to 51CLK <sup>*6</sup>
007F C402h	FLASH	Flash mode register	FMODR	8	8	2 to 3PCLK <sup>*5</sup>
007F C410h	FLASH	Flash access status register	FASTAT	8	8	2 to 3PCLK <sup>*5</sup>
007F C411h	FLASH	Flash access error interrupt enable register	FAEINT	8	8	2 to 3PCLK <sup>*5</sup>
007F C412h	FLASH	Flash ready interrupt enable register	FRDYIE	8	8	2 to 3PCLK <sup>*5</sup>
007F C440h	FLASH	Data flash read enable register 0	DFLRE0	16	16	2 to 3PCLK <sup>*5</sup>
007F C442h	FLASH	Data flash read enable register 1	DFLRE1	16	16	2 to 3PCLK <sup>*5</sup>
007F C450h	FLASH	Data flash programming/erasure enable register 0	DFLWE0	16	16	2 to 3PCLK <sup>*5</sup>
007F C452h	FLASH	Data flash programming/erasure enable register 1	DFLWE1	16	16	2 to 3PCLK <sup>*5</sup>
007F C454h	FLASH	FCU RAM enable register	FCURAME	16	16	2 to 3PCLK <sup>*5</sup>
007F FFB0h	FLASH	Flash status register 0	FSTATR0	8	8	2 to 3PCLK <sup>*5</sup>
007F FFB1h	FLASH	Flash status register 1	FSTATR1	8	8	2 to 3PCLK <sup>*5</sup>
007F FFB2h	FLASH	Flash P/E mode entry register	FENTRYR	16	16	2 to 3PCLK <sup>*5</sup>
007F FFB4h	FLASH	Flash protect register	FPROTR	16	16	2 to 3PCLK <sup>*5</sup>
007F FFB6h	FLASH	Flash reset register	FRESETR	16	16	2 to 3PCLK <sup>*5</sup>
007F FFBAh	FLASH	FCU command register	FCMDR	16	16	2 to 3PCLK <sup>*5</sup>
007F FFC8h	FLASH	FCU processing switching register	FCPSR	16	16	2 to 3PCLK <sup>*5</sup>
007F FFCAh	FLASH	Data flash blank check control register	DFLBCCNT	16	16	2 to 3PCLK <sup>*5</sup>
007F FFCh	FLASH	Flash P/E status register	FPESTAT	16	16	2 to 3PCLK <sup>*5</sup>
007F FFCEh	FLASH	Data flash blank check status register	DFLBCSTAT	16	16	2 to 3PCLK <sup>*5</sup>
007F FFE8h	FLASH	Peripheral clock notification register	PCKAR	16	16	2 to 3PCLK <sup>*5</sup>

Note 1. This register is not supported by the 100-pin LQFP version.

Note 2. This register is not supported by the 80-pin LQFP version.



Note 3. This register is not supported by the 64-pin LQFP version.

Note 4. This register is not supported by the product without the CAN function.

Note 5. The number of access states depends on the number of divided cycles for clock synchronization (0 to 1 PCLK).

Note 6. Reading the registers takes 3 cycles of ICLK and writing to the registers takes 5 cycles of ICLK.

## 5. Electrical Characteristics

### 5.1 Absolute Maximum Ratings

**Table 5.1 Absolute Maximum Ratings**

Item	Symbol	Value	Unit
Power supply voltage	VCC PLLVCC	-0.3 to +6.5	V
Input voltage (except for ports 4 to 6)	$V_{IN}$	-0.3 to VCC+0.3	V
Input voltage (port 4)	$V_{IN}$	-0.3 to AVCC0+0.3	V
Input voltage (ports 5 and 6)	$V_{IN}$	-0.3 to AVCC+0.3	V
Analog power supply voltage	AVCC0, AVCC* <sup>1</sup>	-0.3 to +6.5	V
Reference power supply voltage	VREFH0* <sup>1</sup>	-0.3 to AVCC0+0.3	V
	VREF* <sup>1</sup>	-0.3 to AVCC+0.3	
Analog input voltage (port 4)	$V_{AN}$	-0.3 to AVCC0+0.3	V
Analog input voltage (ports 5 and 6)	$V_{AN}$	-0.3 to AVCC+0.3	V
Operating temperature	$T_{opr}$	-40 to +85	°C
Storage temperature	$T_{stg}$	-55 to +125	°C

Caution: Permanent damage to the LSI may result if absolute maximum ratings are exceeded.

Note 1. When the A/D converter is not in use, do not leave the AVCC0, VREFH0, VREFL0, AVSS0, AVCC, VREF, and AVSS pins open. Connect the AVCC0, VREFH0, AVCC, and VREF pins to VCC, and the AVSS0, VREFL0, and AVSS pins to VSS, respectively.

## 5.2 DC Characteristics

**Table 5.2 DC Characteristics (1) (1 / 3)**

Note: Items for which test conditions are not specifically stated in the table below have the same values under conditions 1 to 3.

Condition 1: VCC = PLLVCC = 2.7 to 3.6 V, VSS = PLLVSS = AVSS0 = AVSS = VREFL0 = 0 V  
AVCC0 = AVCC = 3.0 to 3.6 V, VREFH0 = 3.0 V to AVCC0, VREF = 3.0 V to AVCC

Condition 2: VCC = PLLVCC = 2.7 to 3.6 V, VSS = PLLVSS = AVSS0 = AVSS = VREFL0 = 0V  
AVCC0 = AVCC = 4.0 to 5.5 V, VREFH0 = 4.0 V to AVCC0, VREF = 4.0 V to AVCC

Condition 3: VCC = PLLVCC = 4.0 to 5.5 V, VSS = PLLVSS = AVSS0 = AVSS = VREFL0 = 0V  
AVCC0 = AVCC = 4.0 to 5.5 V, VREFH0 = 4.0 V to AVCC0, VREF = 4.0 V to AVCC  
Ta = -40 to +85°C. Ta is the same under conditions 1 to 3.

Item	Symbol	Min.	Typ.	Max.	Unit	Test Conditions
Schmitt trigger input voltage	CAN input pin IRQ input pin MTU3 input pin POE3 input pin SCI input pin A/D trigger input pin NMI input pin GPT input pin LIN input pin RES#	V <sub>IH</sub>	VCC×0.8	-	VCC+0.3	V
		V <sub>IL</sub>	-0.3	-	VCC×0.2	
		ΔV <sub>T</sub>	VCC ×0.06	-	-	
	RiC input pin (IICBus)	V <sub>IH</sub>	VCC×0.7	-	VCC+0.3	
		V <sub>IL</sub>	-0.3	-	VCC×0.3	
		ΔV <sub>T</sub>	VCC ×0.05	-	-	
	Port 4*1 (also usable as an analog port)	V <sub>IH</sub>	AVCC0 ×0.8	-	AVCC0 +0.3	
		V <sub>IL</sub>	- 0.3	-	AVCC0 ×0.2	
		ΔV <sub>T</sub>	AVCC0 ×0.06	-	-	
	Ports 5 and 6*1 (also usable as analog ports)	V <sub>IH</sub>	AVCC ×0.8	-	AVCC +0.3	
		V <sub>IL</sub>	-0.3	-	AVCC ×0.2	
		ΔV <sub>T</sub>	AVCC ×0.06	-	-	
	Ports 1 to 3*1 Ports 7 to B*1 Ports D, E, and G*1	V <sub>IH</sub>	VCC×0.8	-	VCC+0.3	
		V <sub>IL</sub>	-0.3	-	VCC×0.2	
		ΔV <sub>T</sub>	VCC ×0.06	-	-	
Input high voltage (except Schmitt trigger input pin)	MD pin, EMLE	V <sub>IH</sub>	VCC×0.9	-	VCC+0.3	V
	EXTAL RSPI input pin		VCC×0.8		VCC+0.3	
	RiC input pin (SMBus)		2.1		VCC+0.3	
Input low voltage (except Schmitt trigger input pin)	MD pin, EMLE	V <sub>IL</sub>	-0.3	-	VCC×0.1	V
	EXTAL RSPI input pin		-0.3	-	VCC×0.2	
	RiC input pin (SMBus)		-0.3	-	0.8	

**Table 5.2 DC Characteristics (1) (2 / 3)**

Note: Items for which test conditions are not specifically stated in the table below have the same values under conditions 1 to 3.

Condition 1: VCC = PLLVCC = 2.7 to 3.6 V, VSS = PLLVSS = AVSS0 = AVSS = VREFL0 = 0 V  
AVCC0 = AVCC = 3.0 to 3.6 V, VREFH0 = 3.0 V to AVCC0, VREF = 3.0 V to AVCC

Condition 2: VCC = PLLVCC = 2.7 to 3.6 V, VSS = PLLVSS = AVSS0 = AVSS = VREFL0 = 0V  
AVCC0 = AVCC = 4.0 to 5.5 V, VREFH0 = 4.0 V to AVCC0, VREF = 4.0 V to AVCC

Condition 3: VCC = PLLVCC = 4.0 to 5.5 V, VSS = PLLVSS = AVSS0 = AVSS = VREFL0 = 0V  
AVCC0 = AVCC = 4.0 to 5.5 V, VREFH0 = 4.0 V to AVCC0, VREF = 4.0 V to AVCC  
Ta = -40 to +85°C. Ta is the same under conditions 1 to 3.

Item		Symbol	Min.	Typ.	Max.	Unit	Test Conditions
Output high voltage	All output pins (except for P71 to P76 and P90 to P95)	V <sub>OH</sub>	VCC-0.5	-	-	V	I <sub>OH</sub> = -1 mA
	P71 to P76		VCC-0.5	-	-		I <sub>OH</sub> = -1mA 64-pin LQFP Condition 3
			VCC-1.0	-	-		I <sub>OH</sub> = -5mA 64-pin LQFP Other than condition 3
	P90 to P95		VCC-0.5	-	-		I <sub>OH</sub> = -1mA 80-pin LQFP or 64-pin LQFP
			VCC-1.0	-	-		I <sub>OH</sub> = -5 mA 112-pin LQFP or 100-pin LQFP
Output low voltage	All output pins (except for P71 to P76, P90 to P95, and RIIC)	V <sub>OL</sub>	-	-	0.5	V	I <sub>OL</sub> = 1.0 mA
	P71 to P76		-	-	0.5		I <sub>OL</sub> = 1.0 mA 64-pin LQFP Other than condition 3
			-	-	1.1		I <sub>OL</sub> = 15 mA Conditions 1 and 2
			-	-	1.4		I <sub>OL</sub> = 15 mA Other than 64-pin LQFP Condition 3
	P90 to P95		-	-	0.5		I <sub>OL</sub> = 1.0 mA 80-pin LQFP or 64-pin LQFP
			-	-	1.1		I <sub>OL</sub> = 15 mA 112-pin LQFP or 100-pin LQFP Conditions 1 and 2
			-	-	1.4		I <sub>OL</sub> = 1 mA 112-pin LQFP or 100-pin LQFP Condition 3
			-	-	0.4		I <sub>OL</sub> = 3 mA
	RIIC pin		-	-	0.6		I <sub>OL</sub> = 6 mA
	Input leakage current		RES#, MD pin, EMLE	I <sub>in</sub>	-		-
Three-state leakage current (off state)	Ports 1 to A, PB0, PB3 to PB7, D, E, G	I <sub>TSI</sub>	-	-	1.0	μA	V <sub>in</sub> = 0 V, V <sub>in</sub> = VCC
	Ports PB1 and PB2		-	-	5.0		

**Table 5.2 DC Characteristics (1) (3 / 3)**

Note: Items for which test conditions are not specifically stated in the table below have the same values under conditions 1 to 3.

Condition 1: VCC = PLLVCC = 2.7 to 3.6 V, VSS = PLLVSS = AVSS0 = AVSS = VREFL0 = 0 V  
AVCC0 = AVCC = 3.0 to 3.6 V, VREFH0 = 3.0 V to AVCC0, VREF = 3.0 V to AVCC

Condition 2: VCC = PLLVCC = 2.7 to 3.6 V, VSS = PLLVSS = AVSS0 = AVSS = VREFL0 = 0V  
AVCC0 = AVCC = 4.0 to 5.5 V, VREFH0 = 4.0 V to AVCC0, VREF = 4.0 V to AVCC

Condition 3: VCC = PLLVCC = 4.0 to 5.5 V, VSS = PLLVSS = AVSS0 = AVSS = VREFL0 = 0V  
AVCC0 = AVCC = 4.0 to 5.5 V, VREFH0 = 4.0 V to AVCC0, VREF = 4.0 V to AVCC  
Ta = -40 to +85°C. Ta is the same under conditions 1 to 3.

Item		Symbol	Min.	Typ.	Max.	Unit	Test Conditions
Input capacitance	All input pins (except for ports PB1 and PB2)	C <sub>in</sub>	-	-	15	pF	V <sub>in</sub> = 0 V, f = 1 MHz, T <sub>a</sub> = 25°C
	Ports PB1 and PB2		-	-	30		

Note 1. This includes the multiplexed input pins, except in cases where port pins PB1 and PB2 are used as RIIC input pins or port pins P22 to P24, P30, PA3 to PA5, PB0, PD0 to PD2, or PD6 are used as RSPI input pins.

**Table 5.3 DC Characteristics (2)**

Note: Items for which test conditions are not specifically stated in the table below have the same values under conditions 1 to 3.

Condition 1: VCC = PLLVCC = 2.7 to 3.6 V, VSS = PLLVSS = AVSS0 = AVSS = VREFL0 = 0 V

AVCC0 = AVCC = 3.0 to 3.6 V, VREFH0 = 3.0 V to AVCC0, VREF = 3.0 V to AVCC

Condition 2: VCC = PLLVCC = 2.7 to 3.6 V, VSS = PLLVSS = AVSS0 = AVSS = VREFL0 = 0 V

AVCC0 = AVCC = 4.0 to 5.5 V, VREFH0 = 4.0 V to AVCC0, VREF = 4.0 V to AVCC

Condition 3: VCC = PLLVCC = 4.0 to 5.5 V, VSS = PLLVSS = AVSS0 = AVSS = VREFL0 = 0 V

AVCC0 = AVCC = 4.0 to 5.5 V, VREFH0 = 4.0 V to AVCC0, VREF = 4.0 V to AVCC

Ta = -40 to +85°C. Ta is the same under conditions 1 to 3.

Item		Symbol	Min.	Typ.	Max.	Unit	Test Conditions	
Supply current <sup>*1</sup>	In operation	Max. <sup>*2</sup>	-	-	70	mA	ICLK = 100 MHz PCLK = 50 MHz	
		Normal <sup>*4</sup>		35	-			
		Increased by BGO operation <sup>*5</sup>		15	-			
	Sleep			22	60			
	All-module-clock-stop mode <sup>*6</sup>			14	28			
	Standby mode	Software standby mode		-	0.10	3		mA
Deep software standby mode			-	20	60	μA		
Analog power supply current	During 12-bit A/D conversion (when a sample-and-hold circuit is in use; per unit)		AI <sub>CC0</sub>	-	3	5	mA	
	During 12-bit A/D conversion (when a sample-and-hold circuit is not in use; per unit)			-	3	5	mA	
	Programmable gain amp (per channel)			-	1	2	mA	
	Window comparator (1 channel)				0.5	1	mA	
	Window comparator (6 channels)			-	1	2	mA	
	During 12-bit A/D conversion (per unit)				60	90	μA	
	During 10-bit A/D conversion (per unit)			AI <sub>CC</sub>	-	0.9	2	mA
	Waiting for 10-bit A/D conversion (all units)				-	0.3	3	μA
Reference power supply current	During 12-bit A/D conversion (per unit)		AI <sub>REFH0</sub>	-	1.6	3	mA	
	Waiting for 12-bit A/D conversion (all units)			-	1.6	3	mA	
	During 10-bit A/D conversion (per unit)		AI <sub>REF</sub>	-	0.1	1	mA	
	Waiting for 10-bit A/D conversion (all units)			-	0.1	3	μA	
VCC rising gradient		SV <sub>CC</sub>	-	-	20	ms/V		

Note 1. Supply current values are with all output pins unloaded.

Note 2. Measured with clocks supplied to the peripheral functions. This does not include the BGO operation.

Note 3. I<sub>CC</sub> depends on f (ICLK) as follows. (ICLK : PCLK = 8:4)

ICC max. = 0.54 x f + 16 (max.)

ICC max. = 0.14 x f + 6 (normal operation)

ICC max. = 0.44 x f + 16 (sleep mode)

Note 4. Measured with clocks not supplied to the peripheral functions. This does not include the BGO operation.

Note 5. Incremented if data is written to or erased from the ROM or data flash for data storage during the program execution.

Note 6. The values are for reference.

**Table 5.4 Permissible Output Currents**

Note: Items for which test conditions are not specifically stated in the table below have the same values under conditions 1 to 3.

Condition 1: VCC = PLLVCC = 2.7 to 3.6 V, VSS = PLLVSS = AVSS0 = AVSS = VREFL0 = 0 V  
AVCC0 = AVCC = 3.0 to 3.6 V, VREFH0 = 3.0 V to AVCC0, VREF = 3.0 V to AVCC

Condition 2: VCC = PLLVCC = 2.7 to 3.6 V, VSS = PLLVSS = AVSS0 = AVSS = VREFL0 = 0 V  
AVCC0 = AVCC = 4.0 to 5.5 V, VREFH0 = 4.0 V to AVCC0, VREF = 4.0 V to AVCC

Condition 3: VCC = PLLVCC = 4.0 to 5.5 V, VSS = PLLVSS = AVSS0 = AVSS = VREFL0 = 0 V  
AVCC0 = AVCC = 4.0 to 5.5 V, VREFH0 = 4.0 V to AVCC0, VREF = 4.0 V to AVCC  
Ta = -40 to +85°C. Ta is the same under conditions 1 to 3.

Item	Symbol	Min.	Typ.	Max.	Unit
Permissible output low current (average value per pin)	$I_{OL}$	-	-	2.0 <sup>*1</sup>	mA
Permissible output low current (max. value per pin)	$I_{OL}$	-	-	4.0 <sup>*1</sup>	mA
Permissible output low current (total)	$\Sigma I_{OL}$	-	-	110	mA
Permissible output high current (average value per pin)	- $I_{OH}$	-	-	2.0 <sup>*1</sup>	mA
Permissible output high current (max. value per pin)	- $I_{OH}$	-	-	4.0 <sup>*1</sup>	mA
Permissible output high current (total)	$\Sigma - I_{OH}$	-	-	35	mA

Caution: To protect the LSI's reliability, the output current values should not exceed the permissible output current.

Note 1.  $I_{OL} = 15$  mA (max.) / -  $I_{OH} = 5$  mA (max.) for P71 to P76 and P90 to P95. Note, however, that up to 6 (112-pin or 100-pin LQFP) or 3 (80-pin or 64-pin LQFP) pins can accept over 2.0-mA  $I_{OL}$  / -  $I_{OH}$  at the same time.

### 5.3 AC Characteristics

**Table 5.5 Operation Frequency Value**

Note: Items for which test conditions are not specifically stated in the table below have the same values under conditions 1 to 3.

Condition 1: VCC = PLLVCC = 2.7 to 3.6 V, VSS = PLLVSS = AVSS0 = AVSS = VREFL0 = 0 V  
AVCC0 = AVCC = 3.0 to 3.6 V, VREFH0 = 3.0 V to AVCC0, VREF = 3.0 V to AVCC

Condition 2: VCC = PLLVCC = 2.7 to 3.6 V, VSS = PLLVSS = AVSS0 = AVSS = VREFL0 = 0 V  
AVCC0 = AVCC = 4.0 to 5.5 V, VREFH0 = 4.0 V to AVCC0, VREF = 4.0 V to AVCC

Condition 3: VCC = PLLVCC = 4.0 to 5.5 V, VSS = PLLVSS = AVSS0 = AVSS = VREFL0 = 0 V  
AVCC0 = AVCC = 4.0 to 5.5 V, VREFH0 = 4.0 V to AVCC0, VREF = 4.0 V to AVCC  
Ta = -40 to +85°C. Ta is the same under conditions 1 to 3.

Item	Symbol	Min.	Typ.	Max.	Unit	
Operating frequency	System clock (ICLK)	f	8	-	100	MHz
	Peripheral module clock (PCLK)		8	-	50	

#### 5.3.1 Clock Timing

**Table 5.6 Clock Timing**

Note: Items for which test conditions are not specifically stated in the table below have the same values under conditions 1 to 3.

Condition 1: VCC = PLLVCC = 2.7 to 3.6 V, VSS = PLLVSS = AVSS0 = AVSS = VREFL0 = 0 V  
AVCC0 = AVCC = 3.0 to 3.6 V, VREFH0 = 3.0 V to AVCC0, VREF = 3.0 V to AVCC

Condition 2: VCC = PLLVCC = 2.7 to 3.6 V, VSS = PLLVSS = AVSS0 = AVSS = VREFL0 = 0 V  
AVCC0 = AVCC = 4.0 to 5.5 V, VREFH0 = 4.0 V to AVCC0, VREF = 4.0 V to AVCC

Condition 3: VCC = PLLVCC = 4.0 to 5.5 V, VSS = PLLVSS = AVSS0 = AVSS = VREFL0 = 0 V  
AVCC0 = AVCC = 4.0 to 5.5 V, VREFH0 = 4.0 V to AVCC0, VREF = 4.0 V to AVCC

Ta = -40 to +85°C. Ta is the same under conditions 1 to 3.

Item	Symbol	Min.	Max.	Unit	Test Conditions
Oscillation settling time after reset (crystal)	t <sub>OSC1</sub>	10	-	ms	Figure 5.1
Oscillation settling time after leaving software standby mode (crystal)	t <sub>OSC2</sub>	10	-	ms	Figure 5.2
Oscillation settling time after leaving deep software standby mode (crystal)	t <sub>OSC3</sub>	10	-	ms	Figure 5.3
EXTAL external clock output delay settling time	t <sub>DEXT</sub>	1	-	ms	Figure 5.1
EXTAL external clock input low pulse width	t <sub>EXL</sub>	35	-	ns	Figure 5.4
EXTAL external clock input high pulse width	t <sub>EXH</sub>	35	-	ns	
EXTAL external clock rising time	t <sub>EXr</sub>	-	5	ns	
EXTAL external clock falling time	t <sub>EXf</sub>	-	5	ns	
On-chip oscillator (IWDTCCLK) oscillation frequency	f <sub>IWDTCCLK</sub>	62.5	187.5	kHz	



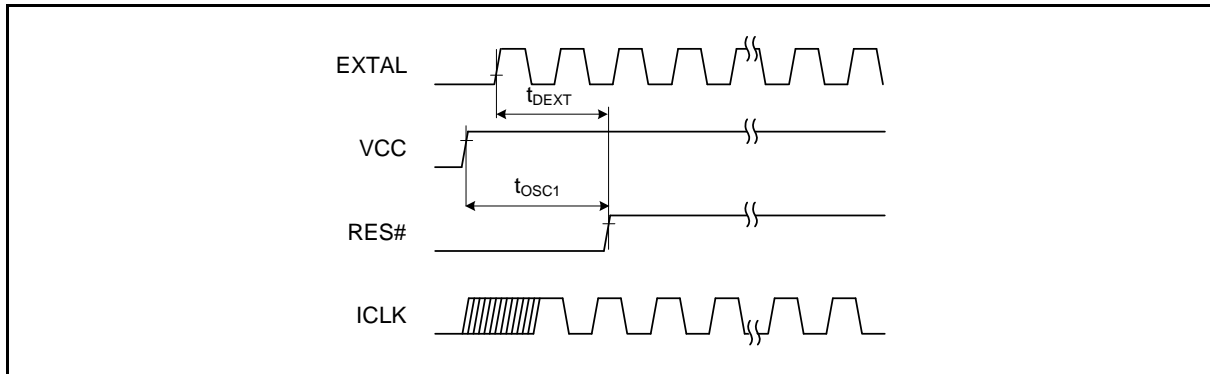

Figure 5.1 Oscillation Settling Timing

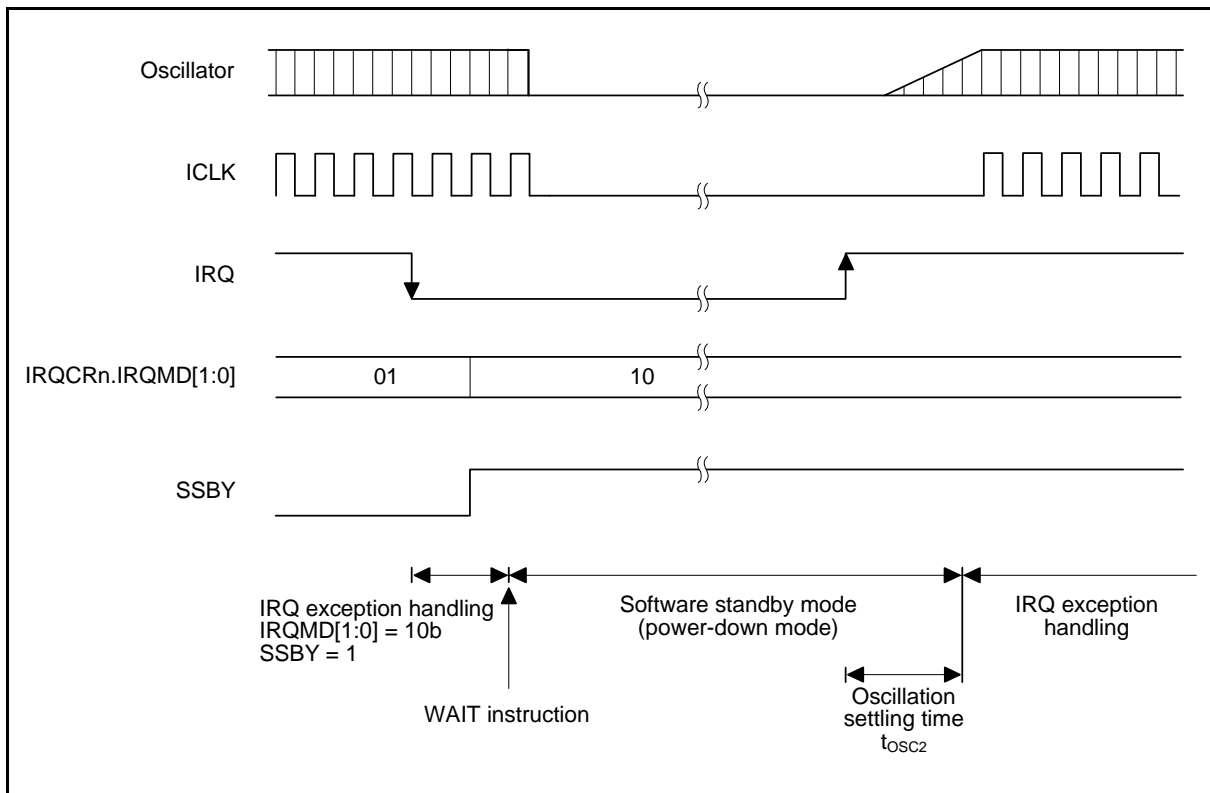

Figure 5.2 Oscillation Settling Timing after Software Standby Mode

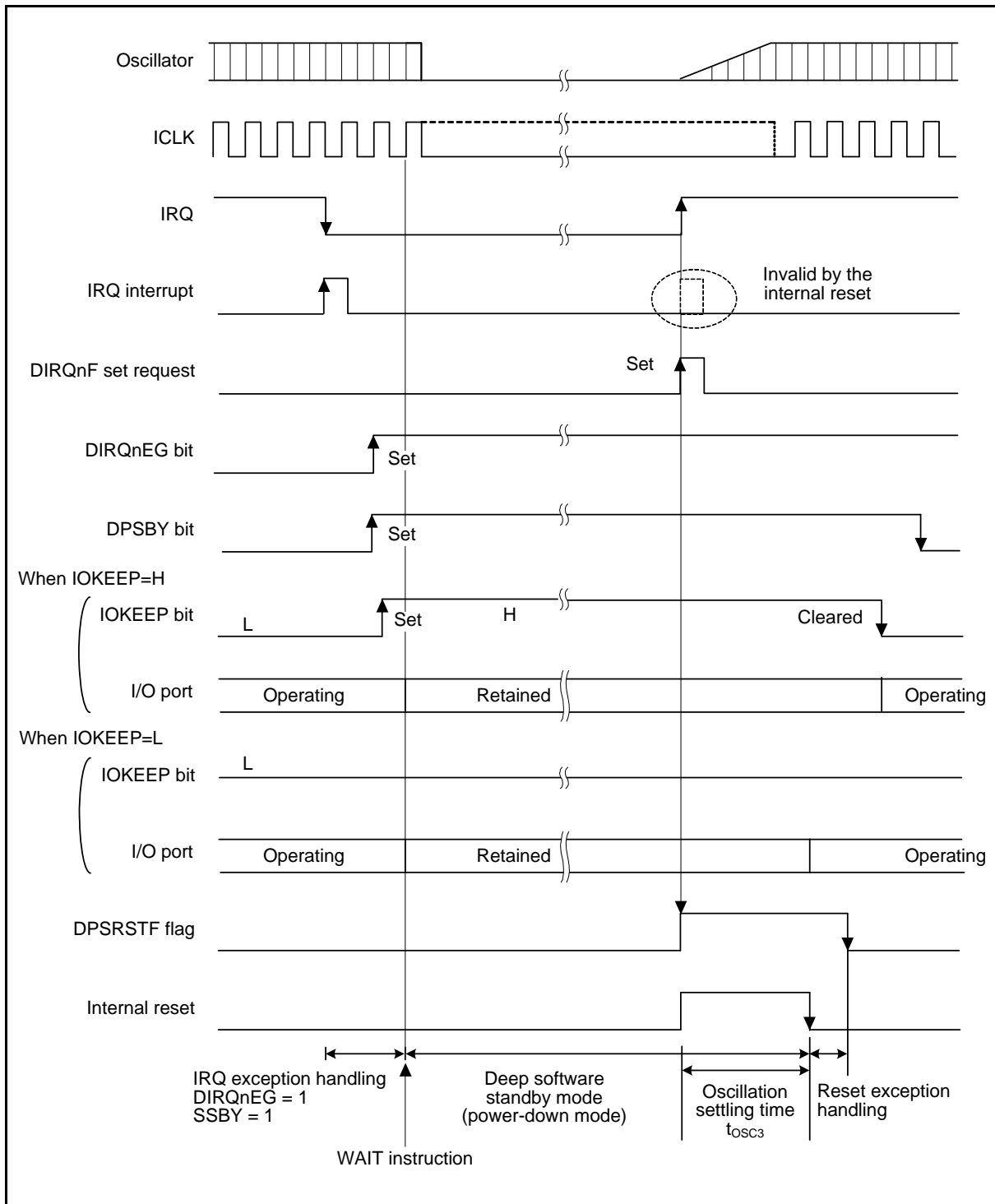

Figure 5.3 Oscillation Settling Timing after Deep Software Standby Mode

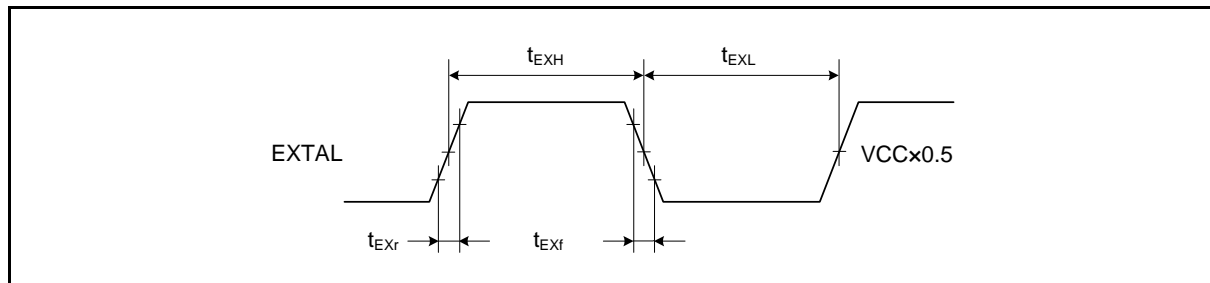

Figure 5.4 EXTAL External Input Clock Timing

### 5.3.2 Control Signal Timing

**Table 5.7 Control Signal Timing**

Note: Items for which test conditions are not specifically stated in the table below have the same values under conditions 1 to 3.

Condition 1: VCC = PLLVCC = 2.7 to 3.6 V, VSS = PLLVSS = AVSS0 = AVSS = VREFL0 = 0 V  
AVCC0 = AVCC = 3.0 to 3.6 V, VREFH0 = 3.0 V to AVCC0, VREF = 3.0 V to AVCC

Condition 2: VCC = PLLVCC = 2.7 to 3.6 V, VSS = PLLVSS = AVSS0 = AVSS = VREFL0 = 0 V  
AVCC0 = AVCC = 4.0 to 5.5 V, VREFH0 = 4.0 V to AVCC0, VREF = 4.0 V to AVCC

Condition 3: VCC = PLLVCC = 4.0 to 5.5 V, VSS = PLLVSS = AVSS0 = AVSS = VREFL0 = 0 V  
AVCC0 = AVCC = 4.0 to 5.5 V, VREFH0 = 4.0 V to AVCC0, VREF = 4.0 V to AVCC  
Ta = -40 to +85°C. Ta is the same under conditions 1 to 3.

Item	Symbol	Min.	Max.	Unit	Test Conditions
RES# pulse width (except for programming or erasure of the ROM or data-flash memory or blank checking of the data-flash memory*1)	$t_{RESW}^{*2}$	20	-	$t_{CYC}^{*4}$	Figure 5.5
		1.5	-	$\mu\text{s}$	
Internal reset time*3	$t_{RESW2}$	35	-	$\mu\text{s}$	
NMI pulse width	$t_{NMIW}$	200	-	ns	Figure 5.6
IRQ pulse width	$t_{IRQW}$	200	-	ns	Figure 5.7

Note 1. Do not allow a reset by the signal on the RES# pin during programming or erasure of the ROM or data-flash memory or during blank checking of the data-flash memory. For details, see section 30.12, Usage Notes in section 30, ROM (Flash Memory for Code Storage).

Note 2. Both the time and the number of cycles should satisfy the specifications.

Note 3. This is to specify the FCU reset and the WDT reset.

Note 4. ICLK cycles.

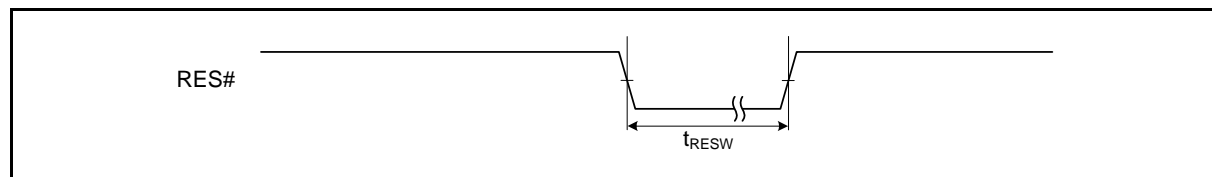

**Figure 5.5 Reset Input Timing**

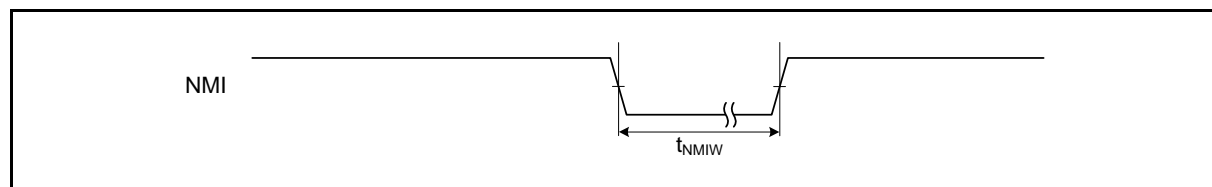

**Figure 5.6 NMI Interrupt Input Timing**

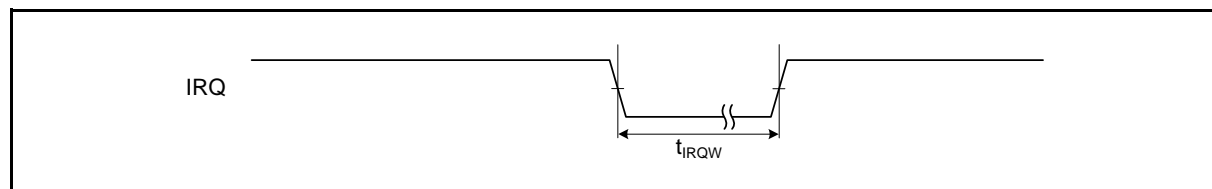

**Figure 5.7 IRQ Interrupt Input Timing**

### 5.3.3 Timing of On-Chip Peripheral Modules

**Table 5.8 Timing of On-Chip Peripheral Modules (1)**

Note: Items for which test conditions are not specifically stated in the table below have the same values under conditions 1 to 3.

Condition 1: VCC = PLLVCC = 2.7 to 3.6 V, VSS = PLLVSS = AVSS0 = AVSS = VREFL0 = 0 V  
 AVCC0 = AVCC = 3.0 to 3.6 V, VREFH0 = 3.0 V to AVCC0, VREF = 3.0 V to AVCC

Condition 2: VCC = PLLVCC = 2.7 to 3.6 V, VSS = PLLVSS = AVSS0 = AVSS = VREFL0 = 0 V  
 AVCC0 = AVCC = 4.0 to 5.5 V, VREFH0 = 4.0 V to AVCC0, VREF = 4.0 V to AVCC

Condition 3: VCC = PLLVCC = 4.0 to 5.5 V, VSS = PLLVSS = AVSS0 = AVSS = VREFL0 = 0 V  
 AVCC0 = AVCC = 4.0 to 5.5 V, VREFH0 = 4.0 V to AVCC0, VREF = 4.0 V to AVCC  
 Ta = -40 to +85°C. Ta is the same under conditions 1 to 3.

Item		Symbol	Min.	Typ.	Max.	Unit	
SCI	Input clock cycle	Asynchronous	$t_{S\text{cyc}}$	$4 \times t_{P\text{cyc}}$	-	ns	Figure 5.8
		Clock synchronous		$6 \times t_{P\text{cyc}}$	-		
	Input clock pulse width		$t_{S\text{CKW}}$	$0.4 \times t_{P\text{cyc}}$	$0.6 \times t_{S\text{cyc}}$	ns	
	Input clock rise time		$t_{S\text{CKr}}$	-	20	ns	
	Input clock fall time		$t_{S\text{CKf}}$	-	20	ns	
	Output clock cycle	Asynchronous	$t_{S\text{cyc}}$	$4 \times t_{P\text{cyc}}$	-	ns	
		Clock synchronous		$6 \times t_{P\text{cyc}}$	-	ns	
	Output clock pulse width		$t_{S\text{CKW}}$	$0.4 \times t_{S\text{cyc}}$	$0.6 \times t_{S\text{cyc}}$	ns	
	Output clock rise time		$t_{S\text{CKr}}$	-	20	ns	
	Output clock fall time		$t_{S\text{CKf}}$	-	20	ns	
Transmit data delay time (clock synchronous)		$t_{T\text{XD}}$	-	40	ns	Figure 5.9	
Receive data setup time (clock synchronous)		$t_{R\text{XS}}$	40	-	ns		
Receive data hold time (clock synchronous)		$t_{R\text{XH}}$	40	-	ns		

Note: •  $t_{P\text{cyc}}$ : PCLK cycle

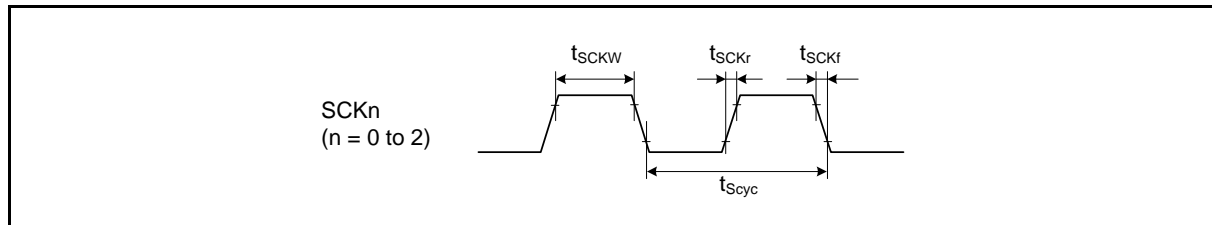

Figure 5.8 SCK Clock Input Timing

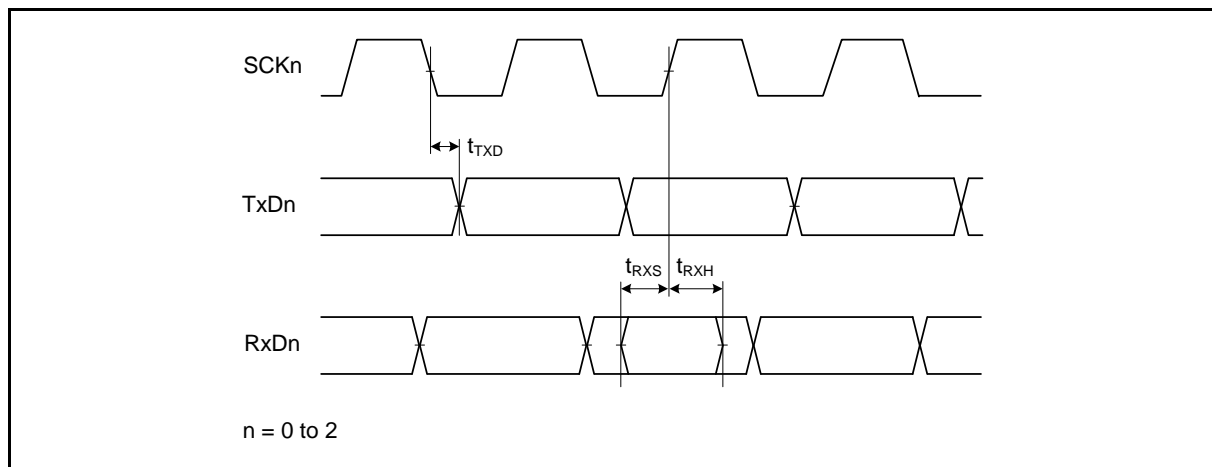

Figure 5.9 SCI Input/Output Timing: Clock Synchronous Mode

**Table 5.9 Timing of On-Chip Peripheral Modules (2)**

Note: Items for which test conditions are not specifically stated in the table below have the same values under conditions 1 to 3.

Condition 1: VCC = PLLVCC = 2.7 to 3.6 V, VSS = PLLVSS = AVSS0 = AVSS = VREFL0 = 0 V  
AVCC0 = AVCC = 3.0 to 3.6 V, VREFH0 = 3.0 V to AVCC0, VREF = 3.0 V to AVCC

Condition 2: VCC = PLLVCC = 2.7 to 3.6 V, VSS = PLLVSS = AVSS0 = AVSS = VREFL0 = 0 V  
AVCC0 = AVCC = 4.0 to 5.5 V, VREFH0 = 4.0 V to AVCC0, VREF = 4.0 V to AVCC

Condition 3: VCC = PLLVCC = 4.0 to 5.5 V, VSS = PLLVSS = AVSS0 = AVSS = VREFL0 = 0 V  
AVCC0 = AVCC = 4.0 to 5.5 V, VREFH0 = 4.0 V to AVCC0, VREF = 4.0 V to AVCC  
Ta = -40 to +85°C. Ta is the same under conditions 1 to 3.

Item	Symbol	Min.*1 *2	Max.	Unit	Test Conditions	
RIIC (standard mode)	SCL input cycle time	$t_{SCL}$	$6(12) \times t_{IICcyc} + 1300$	-	ns	Figure 5.10
	SCL input high pulse width	$t_{SCLH}$	$3(6) \times t_{IICcyc} + 300$	-	ns	
	SCL input low pulse width	$t_{SCLL}$	$3(6) \times t_{IICcyc} + 1000$	-	ns	
	SCL, SDA input rising time	$t_{Sr}$	-	1000	ns	
	SCL, SDA input falling time	$t_{Sf}$	-	300	ns	
	SCL, SDA input spike pulse removal time	$t_{SP}$	0	$1(4) \times t_{IICcyc}$	ns	
	SDA input bus free time	$t_{BUF}$	$3(6) \times t_{IICcyc} + 300$	-	ns	
	Start condition input hold time	$t_{STAH}$	$t_{IICcyc} + 300$	-	ns	
	Re-start condition input setup time	$t_{STAS}$	1000	-	ns	
	Stop condition input setup time	$t_{STOS}$	1000	-	ns	
	Data input setup time	$t_{SDAS}$	$t_{IICcyc} + 50$	-	ns	
	Data input hold time	$t_{SDAH}$	0	-	ns	
	SCL, SDA capacitive load	$C_b$	-	400	pF	
RIIC (fast mode)	SCL input cycle time	$t_{SCL}$	$6(12) \times t_{IICcyc} + 600$	-	ns	
	SCL input high pulse width	$t_{SCLH}$	$3(6) \times t_{IICcyc} + 300$	-	ns	
	SCL input low pulse width	$t_{SCLL}$	$3(6) \times t_{IICcyc} + 300$	-	ns	
	SCL, SDA input rising time	$t_{Sr}$	$20 + 0.1C_b$	300	ns	
	SCL, SDA input falling time	$t_{Sf}$	$20 + 0.1C_b$	300	ns	
	SCL, SDA input spike pulse removal time	$t_{SP}$	0	$1(4) \times t_{IICcyc}$	ns	
	SDA input bus free time	$t_{BUF}$	$3(6) \times t_{IICcyc} + 300$	-	ns	
	Start condition input hold time	$t_{STAH}$	$t_{IICcyc} + 300$	-	ns	
	Re-start condition input setup time	$t_{STAS}$	300	-	ns	
	Stop condition input setup time	$t_{STOS}$	300	-	ns	
	Data input setup time	$t_{SDAS}$	$t_{IICcyc} + 50$	-	ns	
	Data input hold time	$t_{SDAH}$	0	-	ns	
	SCL, SDA capacitive load	$C_b$	-	400	pF	

Note: •  $t_{IICcyc}$ : Cycles of internal base clock (IIC $\phi$ ) for the RIIC module

Note 1. The value in parentheses is used when ICMR3.NF[1:0] are set to 11b while a digital filter is enabled with ICFER.NFE = 1.

Note 2.  $C_b$  indicates the total capacity of the bus line.

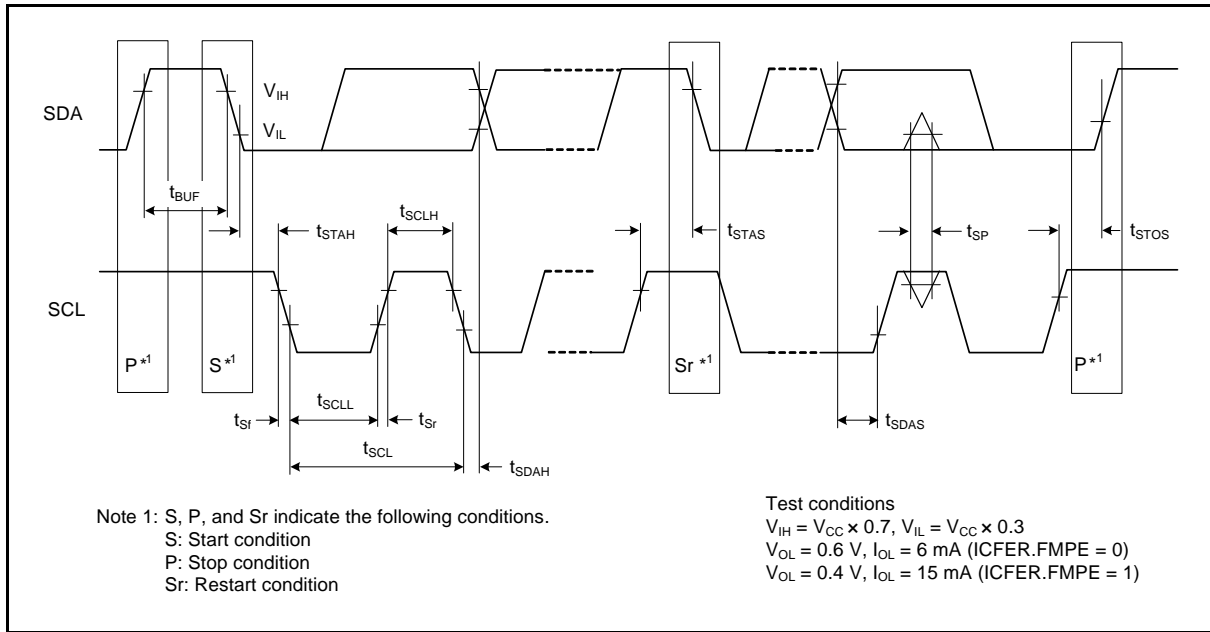

Figure 5.10 I2C Bus Interface Input/Output Timing

**Table 5.10 Timing of On-Chip Peripheral Modules (3)**

Note: Items for which test conditions are not specifically stated in the table below have the same values under conditions 1 to 3.

Condition 1: VCC = PLLVCC = 2.7 to 3.6 V, VSS = PLLVSS = AVSS0 = AVSS = VREFL0 = 0 V  
AVCC0 = AVCC = 3.0 to 3.6 V, VREFH0 = 3.0 V to AVCC0, VREF = 3.0 V to AVCC

Condition 2: VCC = PLLVCC = 2.7 to 3.6 V, VSS = PLLVSS = AVSS0 = AVSS = VREFL0 = 0 V  
AVCC0 = AVCC = 4.0 to 5.5 V, VREFH0 = 4.0 V to AVCC0, VREF = 4.0 V to AVCC

Condition 3: VCC = PLLVCC = 4.0 to 5.5 V, VSS = PLLVSS = AVSS0 = AVSS = VREFL0 = 0 V  
AVCC0 = AVCC = 4.0 to 5.5 V, VREFH0 = 4.0 V to AVCC0, VREF = 4.0 V to AVCC  
Ta = -40 to +85°C. Ta is the same under conditions 1 to 3.

Item		Symbol	Min.	Max.	Unit	Test Conditions		
RSPI	RSPCK clock cycle	Master	t <sub>SPCyc</sub>	4	4096	t <sub>Pcyc</sub>	Figure 5.11	
		Slave		8	4096			
	RSPCK clock high pulse width	Master	t <sub>SPCKWH</sub>	(t <sub>SPcyc</sub> - t <sub>SPCKR</sub> - t <sub>SPCKF</sub> ) / 2-3	-	ns		Figure 5.12 to Figure 5.15
		Slave		(t <sub>SPcyc</sub> - t <sub>SPCKR</sub> - t <sub>SPCKF</sub> ) / 2	-			
	RSPCK clock low pulse width	Master	t <sub>SPCKWL</sub>	(t <sub>SPcyc</sub> - t <sub>SPCKR</sub> - t <sub>SPCKF</sub> ) / 2-3	-	ns		
		Slave		(t <sub>SPcyc</sub> - t <sub>SPCKR</sub> - t <sub>SPCKF</sub> ) / 2	-			
	RSPCK clock rise/fall time	Output	t <sub>SPCKR</sub>	-	5	ns		
		Input	t <sub>SPCKF</sub>	-	1	μs		
	Data input setup time	Master	t <sub>SU</sub>	25	-	ns		
		Slave		0	-			
	Data input hold time	Master	t <sub>H</sub>	0	-	ns		
		Slave		20+2×t <sub>Pcyc</sub>	-			
	SSL setup time	Master	t <sub>LEAD</sub>	1	8	t <sub>SPcyc</sub>		
		Slave		4	-	t <sub>Pcyc</sub>		
	SSL hold time	Master	t <sub>LAG</sub>	1	8	t <sub>SPcyc</sub>		
		Slave		4	-	t <sub>Pcyc</sub>		
	Data output delay time	Master	t <sub>OD</sub>	-	20	ns		
		Slave		-	3×t <sub>Pcyc</sub> +40			
	Data output hold time	Master	t <sub>OH</sub>	0	-	ns		
		Slave		0	-			
Sucessive transmission delay time	Master	t <sub>TD</sub>	t <sub>SPcyc</sub> +2×t <sub>Pcyc</sub>	8×t <sub>SPcyc</sub> +2×t <sub>Pcyc</sub>	ns			
	Slave		4×t <sub>Pcyc</sub>	-				
MOSI, MISO rise/fall time	Output	t <sub>DR</sub>	-	15	ns	Figure 5.12 to Figure 5.15		
	Input	t <sub>DF</sub>	-	1	μs			
SSL rise/fall time	Output	t <sub>SSLR</sub>	-	15	ns			
	Input	t <sub>SSLF</sub>	-	1	μs			
Slave access time		t <sub>SA</sub>	-	4	t <sub>Pcyc</sub>	Figure 5.12 to Figure 5.15		
Slave output release time		t <sub>REL</sub>	-	3	t <sub>Pcyc</sub>			

Note: • Note 1: t<sub>Pcyc</sub>: PCLK cycle



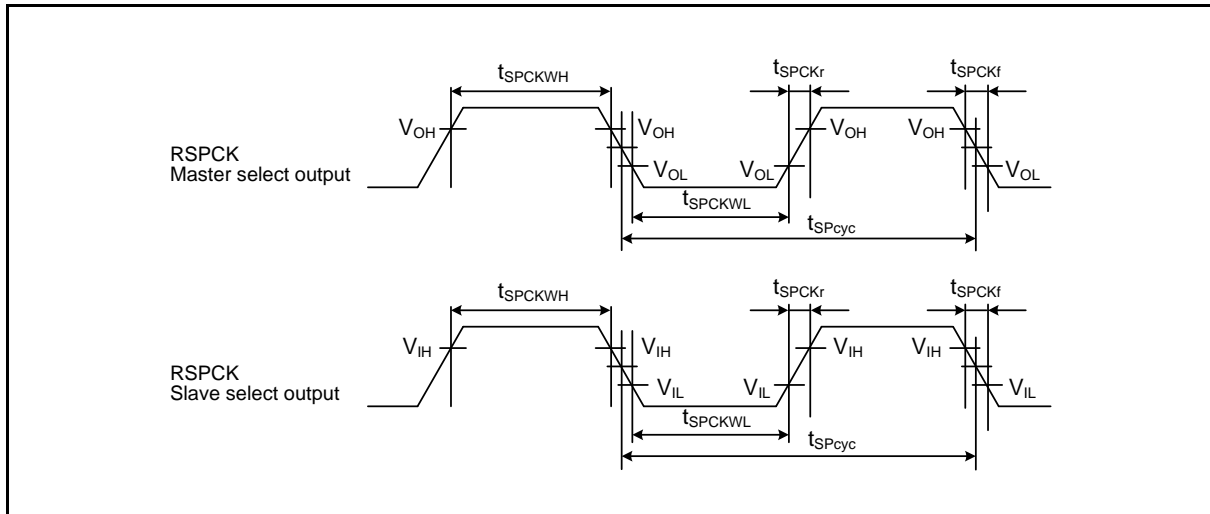

Figure 5.11 RSPCK Clock Timing

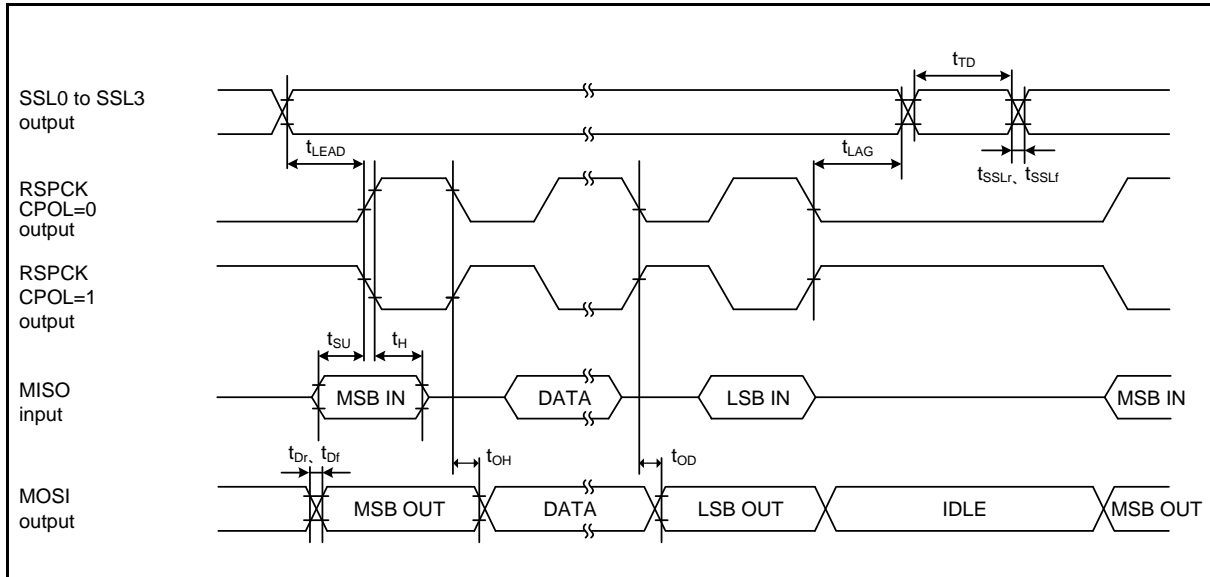

Figure 5.12 RSPCK Timing (Master, CPHA = 0)

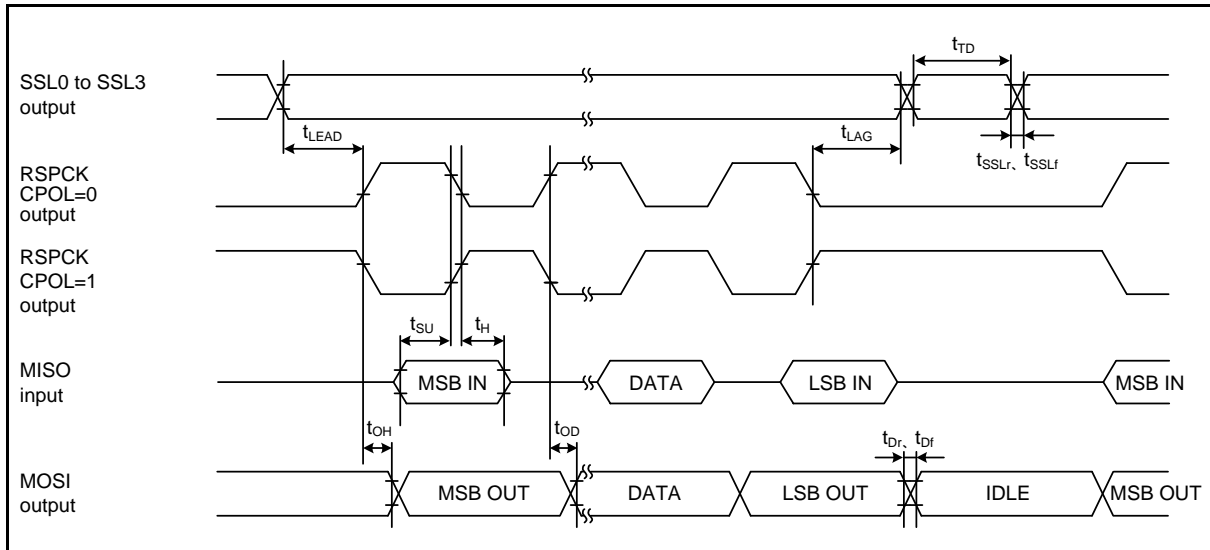

Figure 5.13 RSPI Timing (Master, CPHA = 1)

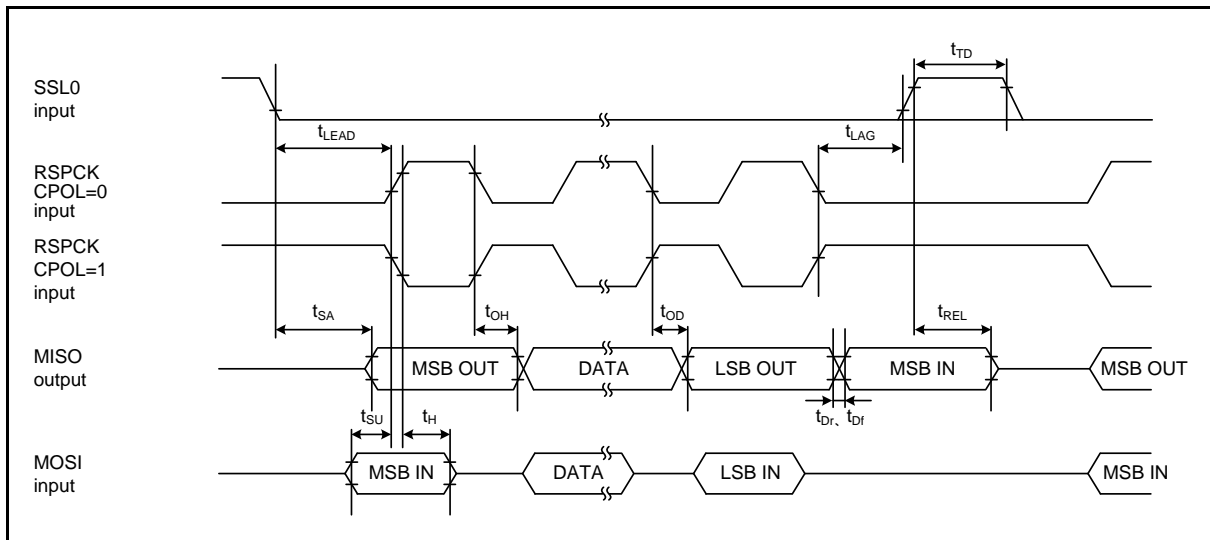

Figure 5.14 RSPI Timing (Slave, CPHA = 0)

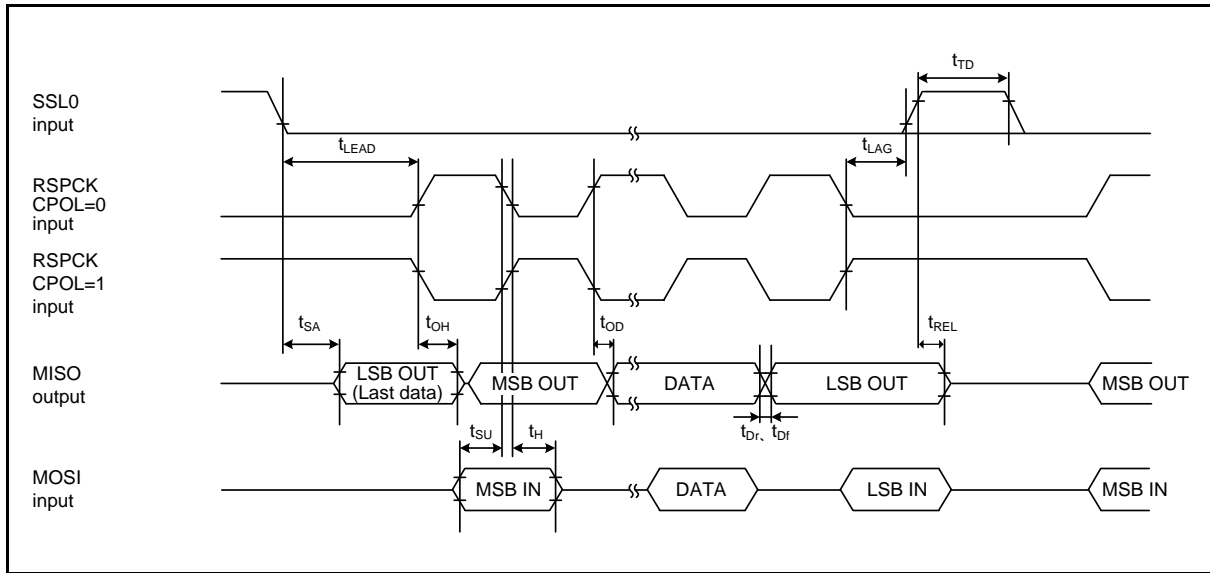

Figure 5.15 RSPI Timing (Slave, CPHA = 1)

**Table 5.11 Timing of On-Chip Peripheral Modules (4)**

Note: Items for which test conditions are not specifically stated in the table below have the same values under conditions 1 to 3.

Condition 1: VCC = PLLVCC = 2.7 to 3.6 V, VSS = PLLVSS = AVSS0 = AVSS = VREFL0 = 0 V  
 AVCC0 = AVCC = 3.0 to 3.6 V, VREFH0 = 3.0 V to AVCC0, VREF = 3.0 V to AVCC

Condition 2: VCC = PLLVCC = 2.7 to 3.6 V, VSS = PLLVSS = AVSS0 = AVSS = VREFL0 = 0 V  
 AVCC0 = AVCC = 4.0 to 5.5 V, VREFH0 = 4.0 V to AVCC0, VREF = 4.0 V to AVCC

Condition 3: VCC = PLLVCC = 4.0 to 5.5 V, VSS = PLLVSS = AVSS0 = AVSS = VREFL0 = 0 V  
 AVCC0 = AVCC = 4.0 to 5.5 V, VREFH0 = 4.0 V to AVCC0, VREF = 4.0 V to AVCC  
 Ta = -40 to +85°C. Ta is the same under conditions 1 to 3.

Item		Symbol	Min.	Max.	Unit	Test Conditions
MTU3	Input capture input pulse width (single-edge setting)	$t_{TICW}$	3.0	-	$t_{cyc}$	Figure 5.16
	Input capture input pulse width (both-edge setting)	$t_{TICW}$	5.0	-	$t_{cyc}$	
	Timer clock pulse width (single-edge setting)	$t_{TCKWH/L}$	3.0	-	$t_{cyc}$	Figure 5.17
	Timer clock pulse width (both-edge setting)	$t_{TCKWH/L}$	5.0	-	$t_{cyc}$	
	Timer clock pulse width (phase coefficient mode)	$t_{TCKWH/L}$	5.0	-	$t_{cyc}$	
GPT	Input capture input pulse width (single-edge setting)	$t_{GTICW}$	3.0	-	$t_{cyc}$	Figure 5.18
	Input capture input pulse width (both-edge setting)	$t_{GTICW}$	5.0	-	$t_{cyc}$	

Note: •  $t_{cyc}$ : ICLK cycle

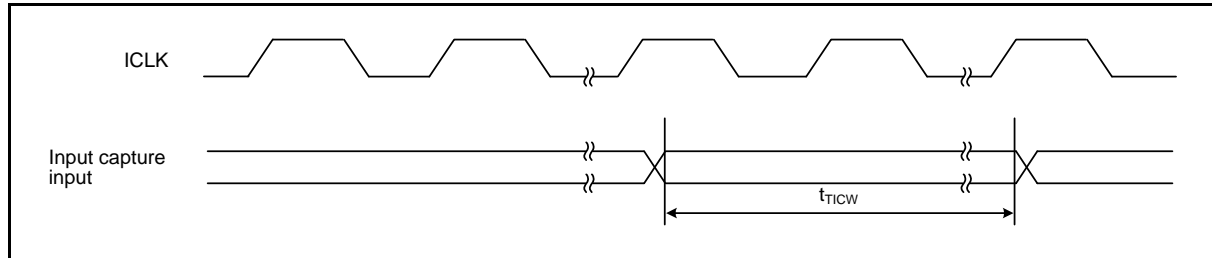

**Figure 5.16 MTU3 Input/Output Timing**

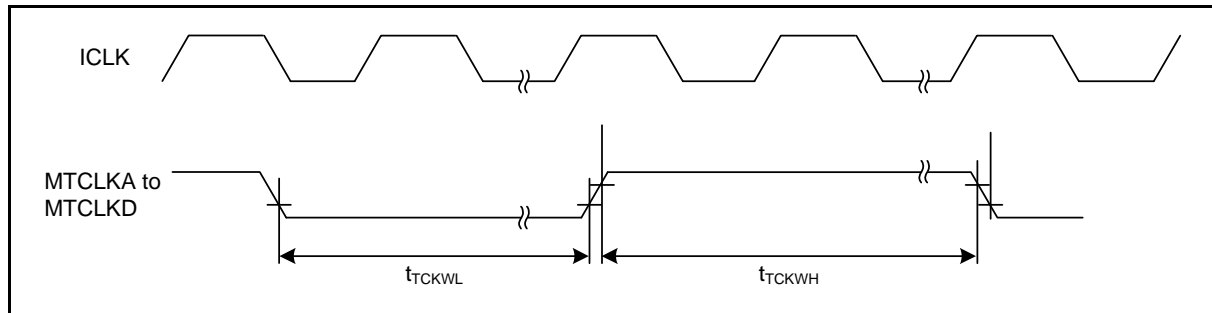

**Figure 5.17 MTU3 Clock Input Timing**

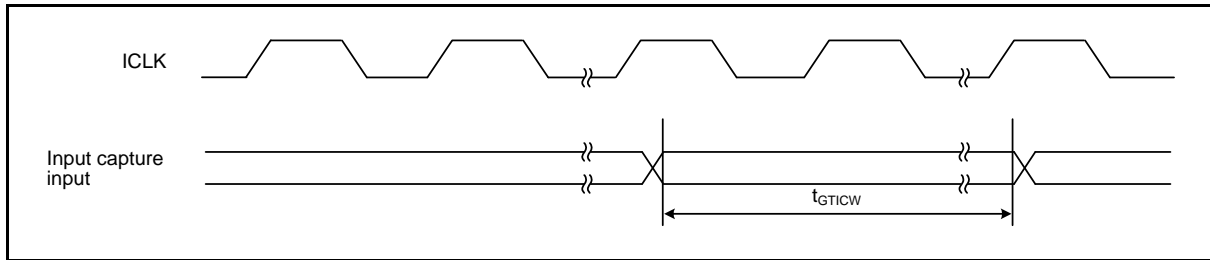

Figure 5.18 GPT Input/Output Timing

Table 5.12 Timing of On-Chip Peripheral Modules (5)

Note: Items for which test conditions are not specifically stated in the table below have the same values under conditions 1 to 3.

Condition 1: VCC = PLLVCC = 2.7 to 3.6 V, VSS = PLLVSS = AVSS0 = AVSS = VREFL0 = 0 V

AVCC0 = AVCC = 3.0 to 3.6 V, VREFH0 = 3.0 V to AVCC0, VREF = 3.0 V to AVCC

Condition 2: VCC = PLLVCC = 2.7 to 3.6 V, VSS = PLLVSS = AVSS0 = AVSS = VREFL0 = 0 V

AVCC0 = AVCC = 4.0 to 5.5 V, VREFH0 = 4.0 V to AVCC0, VREF = 4.0 V to AVCC

Condition 3: VCC = PLLVCC = 4.0 to 5.5 V, VSS = PLLVSS = AVSS0 = AVSS = VREFL0 = 0 V

AVCC0 = AVCC = 4.0 to 5.5 V, VREFH0 = 4.0 V to AVCC0, VREF = 4.0 V to AVCC

Ta = -40 to +85°C. Ta is the same under conditions 1 to 3.

Item	Symbol	Min.	Max.	Unit	Test Conditions
POE3	POE# input pulse width	t <sub>POEW</sub>	1.5	-	t <sub>Pcyc</sub> Figure 5.19

Note: • t<sub>Pcyc</sub>: PCLK cycle

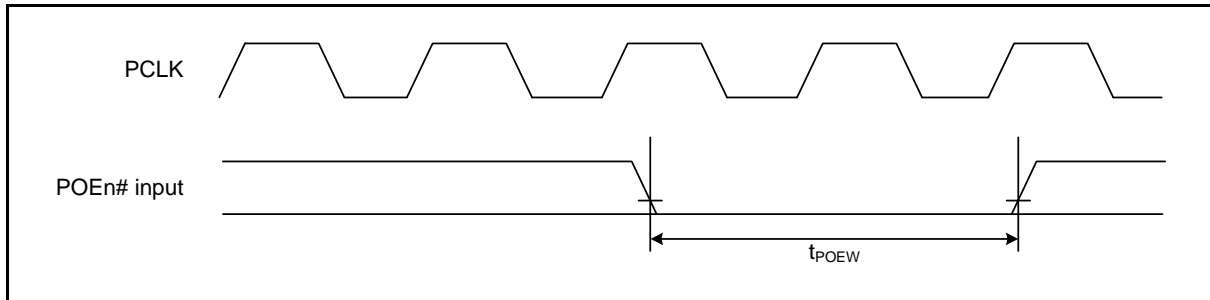

Figure 5.19 POE3# Clock Timing

## 5.4 A/D Conversion Characteristics

**Table 5.13 10-Bit A/D Conversion Characteristics**

Note: Items for which test conditions are not specifically stated in the table below have the same values under conditions 1 to 3.

Condition 1: VCC = PLLVCC = 2.7 to 3.6 V, VSS = PLLVSS = AVSS0 = AVSS = VREFL0 = 0 V  
 AVCC0 = AVCC = 3.0 to 3.6 V, VREFH0 = 3.0 V to AVCC0, VREF = 3.0 V to AVCC  
 Ta = -40 to +85°C

Item	Min.	Typ.	Max.	Unit	Test Conditions
Resolution	10	10	10	Bit	
Conversion time*1 (AD clock = 25-MHz operation)	2.0	-	-	μs	Sampling 25 states
Analog input capacitance	-	-	4	pF	
Integral nonlinearity error	-	-	±3.0	LSB	
Offset error	-	-	±3.0	LSB	
Full-scale error	-	-	±3.0	LSB	
Quantization error	-	±0.5	-	LSB	
Absolute accuracy	-	-	±4.0	LSB	
Permissible signal source impedance	-	-	1.0	kΩ	

Condition 2: VCC = PLLVCC = 2.7 to 3.6 V, VSS = PLLVSS = AVSS0 = AVSS = VREFL0 = 0 V  
 AVCC0 = AVCC = 4.0 to 5.5 V, VREFH0 = 4.0 V to AVCC0, VREF = 4.0 V to AVCC

Condition 3: VCC = PLLVCC = 4.0 to 5.5 V, VSS = PLLVSS = AVSS0 = AVSS = VREFL0 = 0 V  
 AVCC0 = AVCC = 4.0 to 5.5 V, VREFH0 = 4.0 V to AVCC0, VREF = 4.0 V to AVCC  
 Ta = -40 to +85°C. Ta is the same under conditions 1 to 3.

Item	Min.	Typ.	Max.	Unit	Test Conditions
Resolution	10	10	10	Bit	
Conversion time*1 (AD clock = 50-MHz operation)	1.0	-	-	μs	Sampling 25 states
Analog input capacitance	-	-	4	pF	
Integral nonlinearity error	-	-	±3.0	LSB	
Offset error	-	-	±3.0	LSB	
Full-scale error	-	-	±3.0	LSB	
Quantization error	-	±0.5	-	LSB	
Absolute accuracy	-	-	±4.0	LSB	
Permissible signal source impedance	-	-	1.0	kΩ	

Note 1. The conversion time includes the sampling time and the comparison time. As the test conditions, the number of sampling states is indicated.

**Table 5.14 12-Bit A/D Conversion Characteristics**

Note: Items for which test conditions are not specifically stated in the table below have the same values under conditions 1 to 3.

Condition 1: VCC = PLLVCC = 2.7 to 3.6 V, VSS = PLLVSS = AVSS0 = AVSS = VREFL0 = 0 V

AVCC0 = AVCC = 3.0 to 3.6 V, VREFH0 = 3.0 V to AVCC0, VREF = 3.0 V to AVCC

Ta = -40 to +85°C, ICLK = 8 to 100 MHz, PCLK = 8 to 50 MHz

Item	Min.	Typ.	Max.	Unit	Test Conditions	
Resolution	12	12	12	Bit		
Conversion time*1 (AD clock = 25-MHz operation)	2.0	-	-	μs	Sampling 20 states	
Analog input capacitance	-	-	6	pF		
Integral nonlinearity error	-	-	±4.0	LSB		
Offset error	-	-	±7.5	LSB		
Full-scale error	-	-	±7.5	LSB		
Quantization error	-	±0.5	-	LSB		
Absolute accuracy	When a sample-and-hold circuit is in use	-	-	±8.0	LSB	AVin = 0.25 to AVREFH - 0.25
	When a sample-and-hold circuit is not in use	-	-	±8.0	LSB	AVin = AVREFL to AVREFH
Permissible signal source impedance	-	-	3.0	kΩ		

Condition 2: VCC = PLLVCC = 2.7 to 3.6 V, VSS = PLLVSS = AVSS0 = AVSS = VREFL0 = 0 V

AVCC0 = AVCC = 4.0 to 5.5 V, VREFH0 = 4.0 V to AVCC0, VREF = 4.0 V to AVCC

Condition 3: VCC = PLLVCC = 4.0 to 5.5 V, VSS = PLLVSS = AVSS0 = AVSS = VREFL0 = 0 V

AVCC0 = AVCC = 4.0 to 5.5 V, VREFH0 = 4.0 V to AVCC0, VREF = 4.0 V to AVCC

Ta = -40 to +85°C. Ta is the same under conditions 1 to 3. ICLK = 8 to 100 MHz, PCLK = 8 to 50 MHz.

Item	Min.	Typ.	Max.	Unit	Test Conditions	
Resolution	12	12	12	Bit		
Conversion time*1 (AD clock = 25-MHz operation)	1.0	-	-	μs	Sampling 20 states	
Analog input capacitance	-	-	6	pF		
Integral nonlinearity error	-	-	±4.0	LSB		
Offset error	-	-	±7.5	LSB		
Full-scale error	-	-	±7.5	LSB		
Quantization error	-	±0.5	-	LSB		
Absolute accuracy	When a sample-and-hold circuit is in use	-	-	±8.0	LSB	AVin = 0.25 to AVREFH - 0.25
	When a sample-and-hold circuit is not in use	-	-	±8.0	LSB	AVin = AVREFL to AVREFH
Permissible signal source impedance	-	-	3.0	kΩ		

Note 1. The conversion time includes the sampling time and the comparison time. As the test conditions, the number of sampling states is indicated.

**Table 5.15 Programmable Gain Amp Characteristics**

Note: Items for which test conditions are not specifically stated in the table below have the same values under conditions 1 to 3.

Condition 1: VCC = PLLVCC = 2.7 to 3.6 V, VSS = PLLVSS = AVSS0 = AVSS = VREFL0 = 0 V  
 AVCC0 = AVCC = 3.0 to 3.6 V, VREFH0 = 3.0 V to AVCC0, VREF = 3.0 V to AVCC

Condition 2: VCC = PLLVCC = 2.7 to 3.6 V, VSS = PLLVSS = AVSS0 = AVSS = VREFL0 = 0 V  
 AVCC0 = AVCC = 4.0 to 5.5 V, VREFH0 = 4.0 V to AVCC0, VREF = 4.0 V to AVCC

Condition 3: VCC = PLLVCC = 4.0 to 5.5 V, VSS = PLLVSS = AVSS0 = AVSS = VREFL0 = 0 V  
 AVCC0 = AVCC = 4.0 to 5.5V, VREFH0 = 4.0 V to AVCC0, VREF = 4.0 V to AVCC  
 Ta = -40 to +85°C. Ta is the same under conditions 1 to 3.

Item	Symbol	Min.	Typ.	Max.	Unit	Test Conditions
Analog input capacitance	Cin	-	-	6	pF	
Input offset voltage	Voff	-	-	8	mV	
Input voltage range (Vin)	Gain × 2.000	0.050 × AVcc	-	0.38 × AVcc	V	
	Gain × 2.500	0.047 × AVcc	-	0.30 × AVcc		
	Gain × 3.077	0.045 × AVcc	-	0.24 × AVcc		
	Gain × 3.636	0.042 × AVcc	-	0.21 × AVcc		
	Gain × 4.000	0.040 × AVcc	-	0.19 × AVcc		
	Gain × 4.444	0.036 × AVcc	-	0.17 × AVcc		
	Gain × 5.000	0.033 × AVcc	-	0.15 × AVcc		
	Gain × 5.714	0.031 × AVcc	-	0.13 × AVcc		
	Gain × 6.667	0.029 × AVcc	-	0.11 × AVcc		
	Gain × 10.000	0.025 × AVcc	-	0.08 × AVcc		
Gain × 13.333	0.023 × AVcc	-	0.06 × AVcc			
Slew rate	SR	10	-	-	V/μs	
Gain error	Gain × 2.000	-	-	1	%	
	Gain × 2.500	-	-	1		
	Gain × 3.077	-	-	1		
	Gain × 3.636	-	-	1.5		
	Gain × 4.000	-	-	1.5		
	Gain × 4.444	-	-	2		
	Gain × 5.000	-	-	2		
	Gain × 5.714	-	-	2		
	Gain × 6.667	-	-	3		
	Gain × 10.000	-	-	4		
Gain × 13.333	-	-	4			



**Table 5.16 Comparator Characteristics**

Note: Items for which test conditions are not specifically stated in the table below have the same values under conditions 1 to 3.

Condition 1: VCC = PLLVCC = 2.7 to 3.6 V, VSS = PLLVSS = AVSS0 = AVSS = VREFL0 = 0 V

AVCC0 = AVCC = 3.0 to 3.6 V, VREFH0 = 3.0 V to AVCC0, VREF = 3.0 V to AVCC

Condition 2: VCC = PLLVCC = 2.7 to 3.6 V, VSS = PLLVSS = AVSS0 = AVSS = VREFL0 = 0 V

AVCC0 = AVCC = 4.0 to 5.5 V, VREFH0 = 4.0 V to AVCC0, VREF = 4.0 V to AVCC

Condition 3: VCC = PLLVCC = 4.0 to 5.5 V, VSS = PLLVSS = AVSS0 = AVSS = VREFL0 = 0 V

AVCC0 = AVCC = 4.0 to 5.5 V, VREFH0 = 4.0 V to AVCC0, VREF = 4.0 V to AVCC

Ta = -40 to +85°C. Ta is the same under conditions 1 to 3.

Item	Symbol	Min.	Typ.	Max.	Unit	Test Conditions
Analog input capacitance	Cin	-	-	6	pF	
REFH pin offset voltage	Voff	-	-	5	mV	
REFL pin offset voltage		-	-	5	mV	
REFH input voltage range	Vin	1.7	-	AVcc - 0.3	V	
REFL input voltage range		0.3	-	AVcc - 1.7	V	
REFH reply time	tCR	-	-	1	μs	
REFL reply time	tCF	-	-	1	μs	

5.5 Power-on Reset Circuit, Voltage Detection Circuit Characteristics

**Table 5.17 Power-on Reset Circuit, Voltage Detection Circuit Characteristics**

Note: Items for which test conditions are not specifically stated in the table below have the same values under conditions 1 to 3.

Condition 1: VCC = PLLVCC = 2.7 to 3.6 V, VSS = PLLVSS = AVSS0 = AVSS = VREFL0 = 0 V  
 AVCC0 = AVCC = 3.0 to 3.6 V, VREFH0 = 3.0 V to AVCC0, VREF = 3.0 V to AVCC

Condition 2: VCC = PLLVCC = 2.7 to 3.6 V, VSS = PLLVSS = AVSS0 = AVSS = VREFL0 = 0 V  
 AVCC0 = AVCC = 4.0 to 5.5 V, VREFH0 = 4.0 V to AVCC0, VREF = 4.0 V to AVCC  
 Ta = -40 to +85°C. Ta is the same under conditions 1 to 3.

Item		Symbol	Min.	Typ.	Max.	Unit	Test Conditions
Voltage detection level	Power-on reset (POR)	V <sub>POR</sub>	2.48	2.60	2.72	V	Figure 5.20
	Voltage detection circuit (LVD)	V <sub>det1</sub>	2.68	2.80	2.92		Figure 5.21
		V <sub>det2</sub>	2.98	3.10	3.22		Figure 5.22
Internal reset time		t <sub>POR</sub>	20	35	50	ms	Figure 5.21 and Figure 5.22
Min. VCC down time *1		t <sub>VOFF</sub>	200	-	-	us	Figure 5.20 to Figure 5.22
Reply delay time		t <sub>det</sub>	-	-	200	us	

Condition 3: VCC = PLLVCC = 4.0 to 5.5 V, VSS = PLLVSS = AVSS0 = AVSS = VREFL0 = 0 V  
 AVCC0 = AVCC = 4.0 to 5.5 V, VREFH0 = 4.0 V to AVCC0, VREF = 4.0 V to AVCC  
 Ta = -40 to +85°C

Item		Symbol	Min.	Typ.	Max.	Unit	Test Conditions
Voltage detection level	Power-on reset (POR)	V <sub>POR</sub>	3.70	3.90	4.10	V	Figure 5.20
	Voltage detection circuit (LVD)	V <sub>det1</sub>	3.95	4.15	4.35		Figure 5.21
		V <sub>det2</sub>	4.40	4.60	4.80		Figure 5.22
Internal reset time		t <sub>POR</sub>	20	35	50	ms	Figure 5.21 and Figure 5.22
Min. VCC down time *1		t <sub>VOFF</sub>	200	-	-	us	Figure 5.20 to Figure 5.22
Reply delay time		t <sub>det</sub>	-	-	200	us	

Note 1. The power-off time indicates the time when VCC is below the minimum value of voltage detection levels V<sub>POR</sub>, V<sub>det1</sub>, and V<sub>det2</sub> for the POR/ LVD.

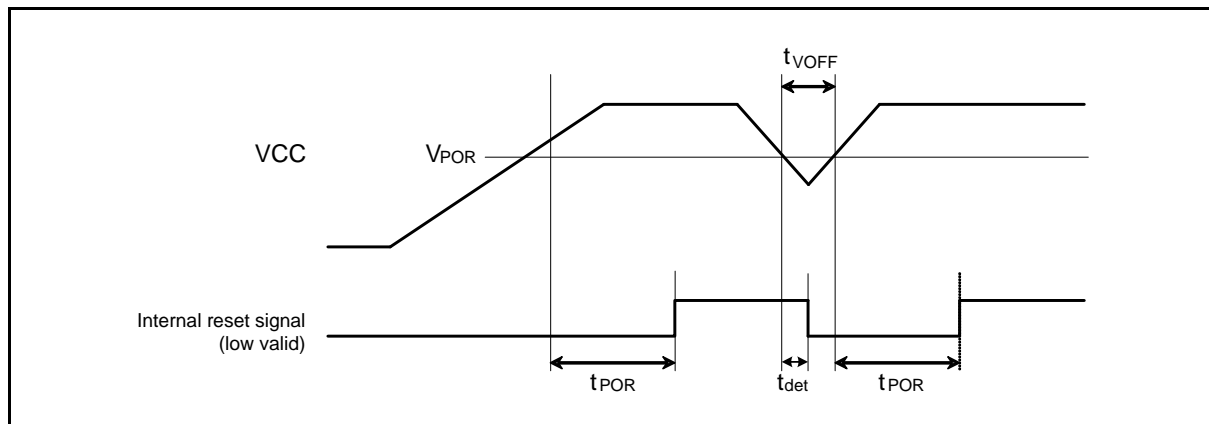

**Figure 5.20 Power-on Reset Timing**

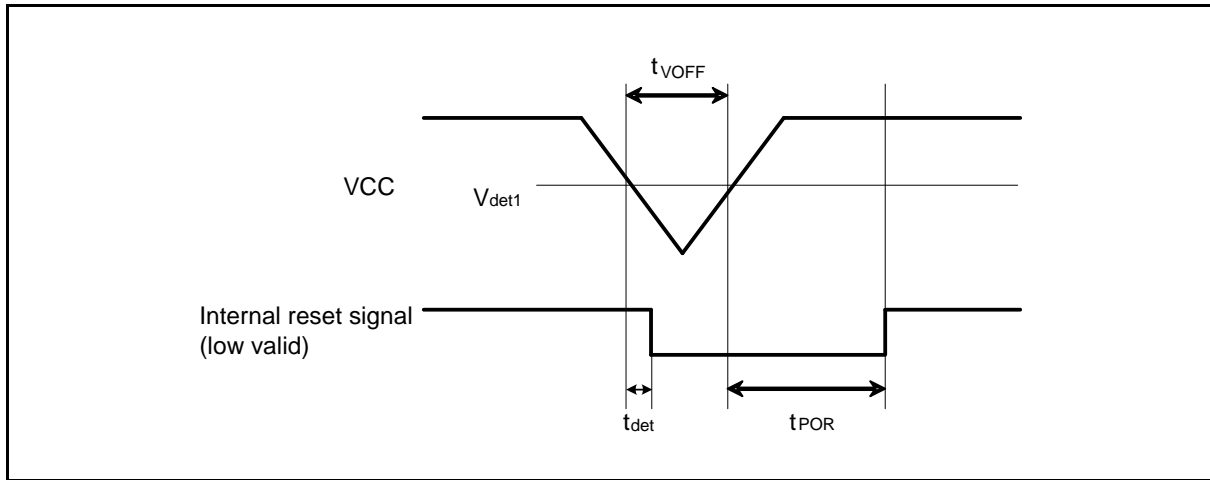

Figure 5.21 Voltage Detection Circuit Timing (Vdet1)

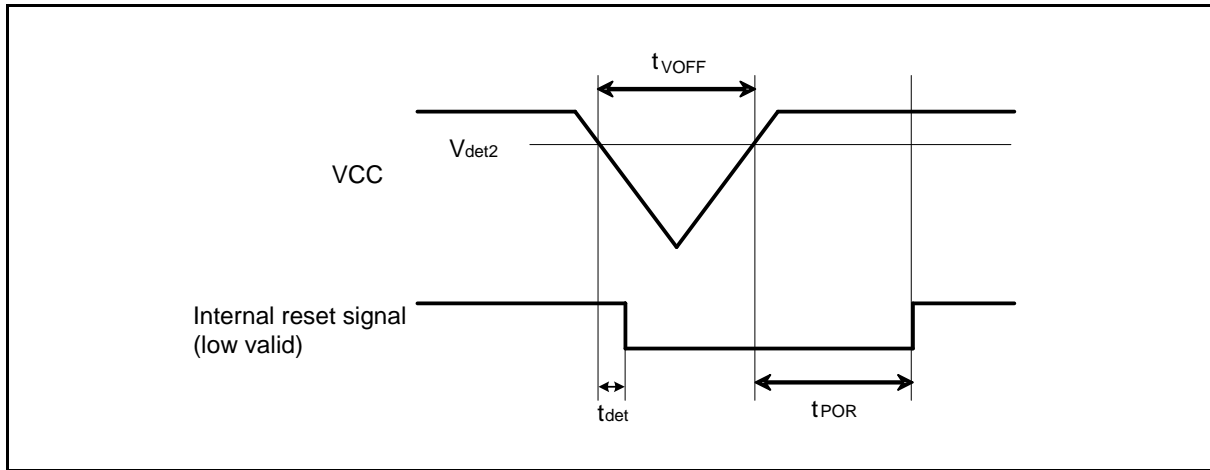

Figure 5.22 Voltage Detection Circuit Timing (Vdet2)

5.6 Oscillation Stop Detection Timing

**Table 5.18 Oscillation Stop Detection Circuit Characteristics**

Note: Items for which test conditions are not specifically stated in the table below have the same values under conditions 1 to 3.

Condition 1: VCC = PLLVCC = 2.7 to 3.6 V, VSS = PLLVSS = AVSS0 = AVSS = VREFL0 = 0 V  
 AVCC0 = AVCC = 3.0 to 3.6 V, VREFH0 = 3.0 V to AVCC0, VREF = 3.0 V to AVCC

Condition 2: VCC = PLLVCC = 2.7 to 3.6 V, VSS = PLLVSS = AVSS0 = AVSS = VREFL0 = 0 V  
 AVCC0 = AVCC = 4.0 to 5.5 V, VREFH0 = 4.0 V to AVCC0, VREF = 4.0 V to AVCC

Condition 3: VCC = PLLVCC = 4.0 to 5.5 V, VSS = PLLVSS = AVSS0 = AVSS = VREFL0 = 0 V  
 AVCC0 = AVCC = 4.0 to 5.5 V, VREFH0 = 4.0 V to AVCC0, VREF = 4.0 V to AVCC  
 Ta = -40 to +85°C. Ta is the same under conditions 1 to 3.

Item	Symbol	Min.	Typ.	Max.	Unit	Test Conditions
Detection time	tdr	-	-	1.0	ms	Figure 5.23
Internal oscillation frequency when oscillation stop is detected	f <sub>MAIN</sub>	0.5	-	7.0	MHz	

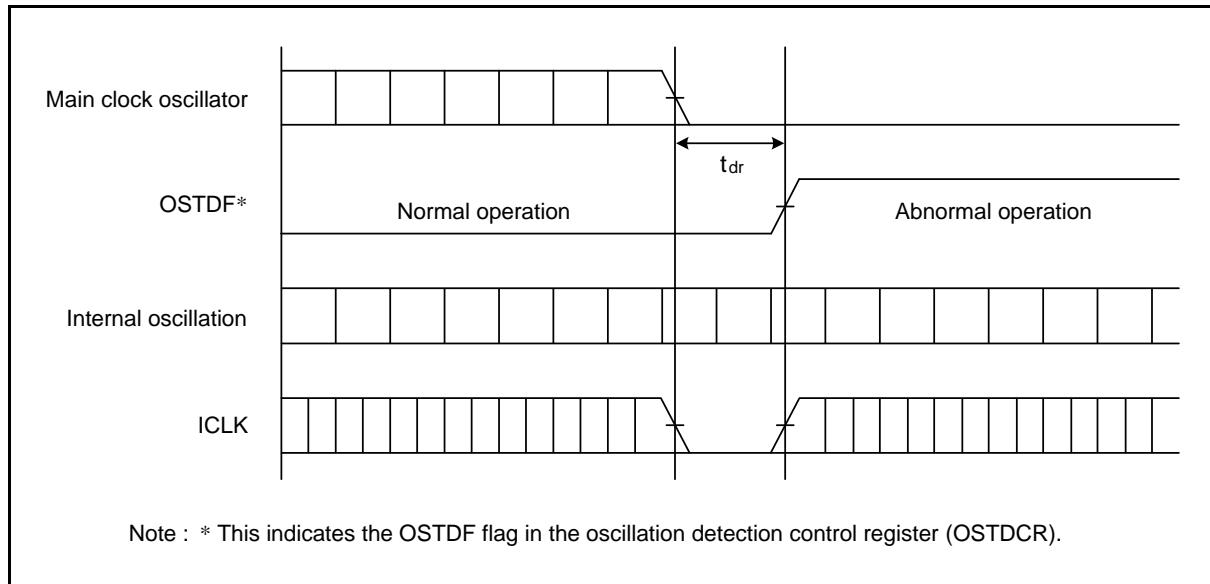

**Figure 5.23 Oscillation Stop Detection Timing**

## 5.7 ROM (Flash Memory for Code Storage) Characteristics

**Table 5.19 ROM (Flash Memory for Code Storage) Characteristics**

Note: Items for which test conditions are not specifically stated in the table below have the same values under conditions 1 to 3.

Condition 1: VCC = PLLVCC = 2.7 to 3.6 V, VSS = PLLVSS = AVSS0 = AVSS = VREFL0 = 0 V  
AVCC0 = AVCC = 3.0 to 3.6 V, VREFH0 = 3.0 V to AVCC0, VREF = 3.0 V to AVCC

Condition 2: VCC = PLLVCC = 2.7 to 3.6 V, VSS = PLLVSS = AVSS0 = AVSS = VREFL0 = 0 V  
AVCC0 = AVCC = 4.0 to 5.5 V, VREFH0 = 4.0 V to AVCC0, VREF = 4.0 V to AVCC

Condition 3: VCC = PLLVCC = 4.0 to 5.5 V, VSS = PLLVSS = AVSS0 = AVSS = VREFL0 = 0 V  
AVCC0 = AVCC = 4.0 to 5.5 V, VREFH0 = 4.0 V to AVCC0, VREF = 4.0 V to AVCC

Temperature range for the programming/erasure operation:

Ta = -40 to +85°C. Ta is the same under conditions 1 to 3.

Item		Symbol	Min.	Typ.	Max.	Unit	Test Conditions	
Programming time	256 bytes	t <sub>P256</sub>	-	2	12	ms	PCLK = 50 MHz N <sub>PEC</sub> ≤ 100	
	4 Kbytes	t <sub>P4K</sub>	-	23	50	ms		
	16 Kbytes	t <sub>P16K</sub>	-	90	200	ms		
		256 byte	t <sub>P256</sub>	-	2.4	14.4	ms	PCLK = 50 MHz N <sub>PEC</sub> > 100
		4 Kbytes	t <sub>P4K</sub>	-	27.6	60	ms	
		16 Kbytes	t <sub>P16K</sub>	-	108	240	ms	
Erasure time	4 Kbytes	t <sub>E4K</sub>	-	25	60	ms	PCLK = 50 MHz N <sub>PEC</sub> ≤ 100	
	16 Kbytes	t <sub>E16K</sub>	-	100	240	ms		
		4 Kbytes	t <sub>E4K</sub>	-	30	72	ms	PCLK = 50 MHz N <sub>PEC</sub> > 100
		16 Kbytes	t <sub>E16K</sub>	-	120	288	ms	
Rewrite/erase cycle <sup>*1</sup>		N <sub>PEC</sub>	1000 <sup>*2</sup>	-	-	Times		
Suspend delay time during writing		t <sub>SPD</sub>	-	-	120	μs	Figure 5.24 PCLK = 50 MHz	
First suspend delay time during erasing (in suspend priority mode)		t <sub>SESD1</sub>	-	-	120	μs		
Second suspend delay time during erasing (in suspend priority mode)		t <sub>SESD2</sub>	-	-	1.7	ms		
Suspend delay time during erasing (in erasure priority mode)		t <sub>SEED</sub>	-	-	1.7	ms		
Data hold time <sup>*3</sup>		t <sub>DRP</sub>	10	-	-	Year		

Note 1. Definition of rewrite/erase cycle:

The rewrite/erase cycle is the number of erasing for each block. When the rewrite/erase cycle is n times (n = 1000), erasing can be performed n times for each block. For instance, when 256-byte writing is performed 16 times for different addresses in 4-Kbyte block and then the entire block is erased, the rewrite/erase cycle is counted as one. However, writing to the same address for several times as one erasing is not enabled (overwriting is prohibited).

Note 2. This indicates the minimum number that guarantees the characteristics after rewriting. (The guaranteed value is in the range from one to the minimum number.)

Note 3. This indicates the characteristic when rewrite is performed within the specification range including the minimum number.

## 5.8 Data Flash (Flash Memory for Data Storage) Characteristics

**Table 5.20 Data Flash (Flash Memory for Data Storage) Characteristics**

Note: Items for which test conditions are not specifically stated in the table below have the same values under conditions 1 to 3.

Condition 1: VCC = PLLVCC = 2.7 to 3.6 V, VSS = PLLVSS = AVSS0 = AVSS = VREFL0 = 0 V  
AVCC0 = AVCC = 3.0 to 3.6 V, VREFH0 = 3.0 V to AVCC0, VREF = 3.0 V to AVCC

Condition 2: VCC = PLLVCC = 2.7 to 3.6 V, VSS = PLLVSS = AVSS0 = AVSS = VREFL0 = 0 V  
AVCC0 = AVCC = 4.0 to 5.5 V, VREFH0 = 4.0 V to AVCC0, VREF = 4.0 V to AVCC

Condition 3: VCC = PLLVCC = 4.0 to 5.5 V, VSS = PLLVSS = AVSS0 = AVSS = VREFL0 = 0 V  
AVCC0 = AVCC = 4.0 to 5.5 V, VREFH0 = 4.0 V to AVCC0, VREF = 4.0 V to AVCC

Temperature range for the programming/erasure operation:

Ta = -40 to +85°C. Ta is the same under conditions 1 to 3.

Item		Symbol	Min.	Typ.	Max.	Unit	Test Conditions
Programming time	8 bytes	t <sub>DP8</sub>	-	0.4	2	ms	PCLK = 50 MHz
	128 bytes	t <sub>DP128</sub>	-	1	5	ms	
Erase time	2 Kbytes	t <sub>DE2K</sub>	-	70	250	ms	PCLK = 50 MHz
Blank check time	8 bytes	t <sub>DBC8</sub>	-	-	30	μs	PCLK = 50 MHz
	2 Kbytes	t <sub>DBC2K</sub>	-	-	0.7	ms	
Rewrite/erase cycle <sup>*1</sup>		N <sub>DPEC</sub>	30000 <sup>*2</sup>	-	-	Times	
Suspend delay time during writing		t <sub>DSPD</sub>	-	-	120	μs	Figure 5.24 PCLK = 50 MHz
First suspend delay time during erasing (in suspend priority mode)		t <sub>DSESD1</sub>	-	-	120	μs	
Second suspend delay time during erasing (in suspend priority mode)		t <sub>DSESD2</sub>	-	-	1.7	ms	
Suspend delay time during erasing (in erasure priority mode)		t <sub>DSEED</sub>	-	-	1.7	ms	
Data hold time <sup>*3</sup>		t <sub>DDRP</sub>	10	-	-	Year	

Note 1. Definition of rewrite/erase cycle:

The rewrite/erase cycle is the number of erasing for each block. When the rewrite/erase cycle is n times (n = 30000), erasing can be performed n times for each block. For instance, when 128-byte writing is performed 16 times for different addresses in 2-Kbyte block and then the entire block is erased, the rewrite/erase cycle is counted as one. However, writing to the same address for several times as one erasing is not enabled (overwriting is prohibited).

Note 2. This indicates the minimum number that guarantees the characteristics after rewriting. (The guaranteed value is in the range from one to the minimum number.)

Note 3. This indicates the characteristic when rewrite is performed within the specification range including the minimum number.

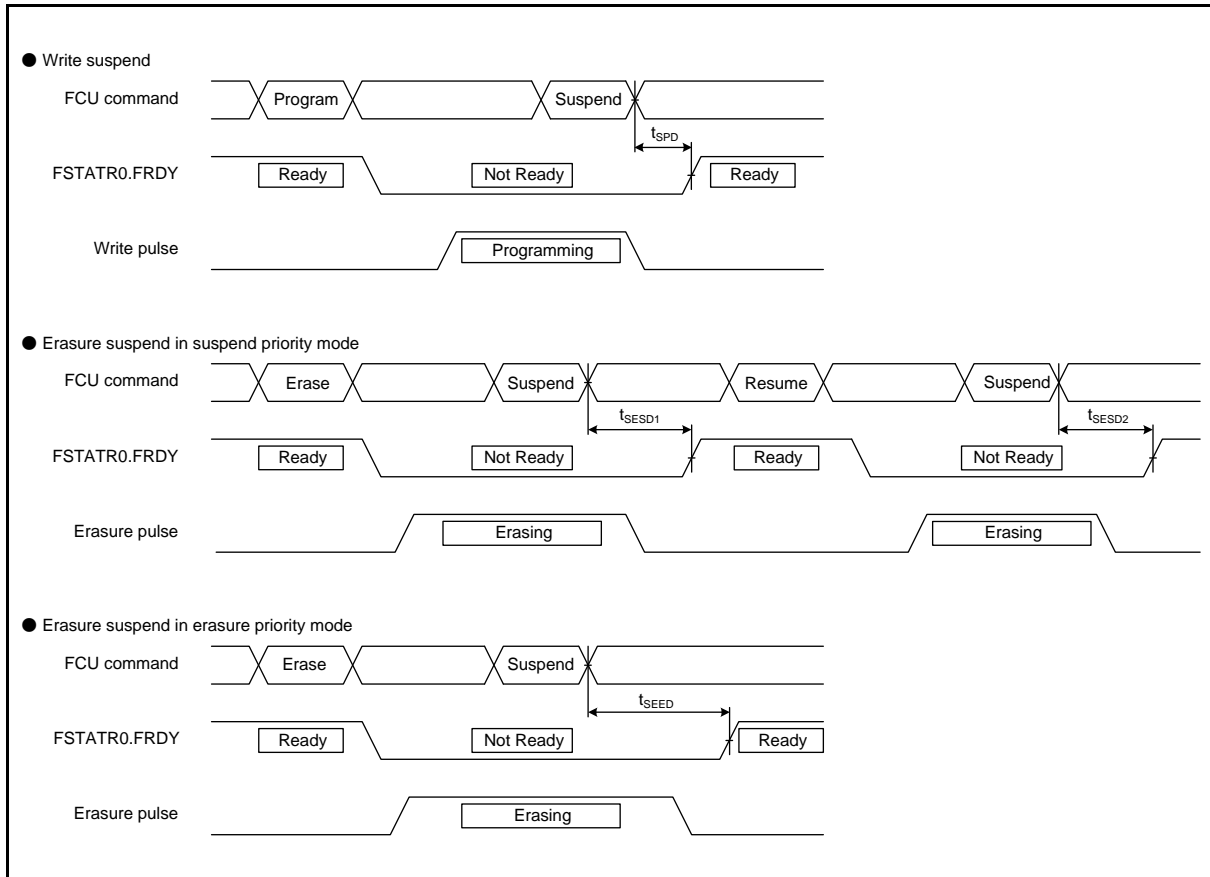

Figure 5.24 Flash Memory Write/Erase Suspend Timing

### Appendix 1. Package Dimensions

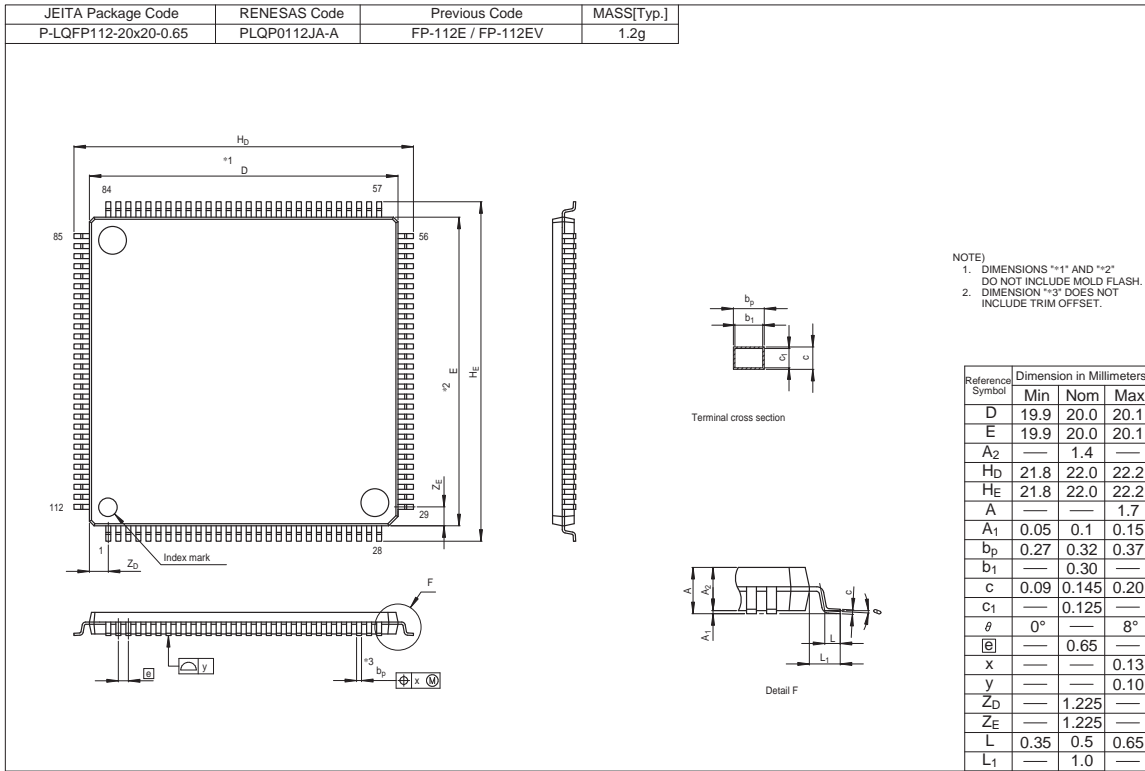

Figure A 112-Pin LQFP (PLQP0112JA-A) Package Dimensions



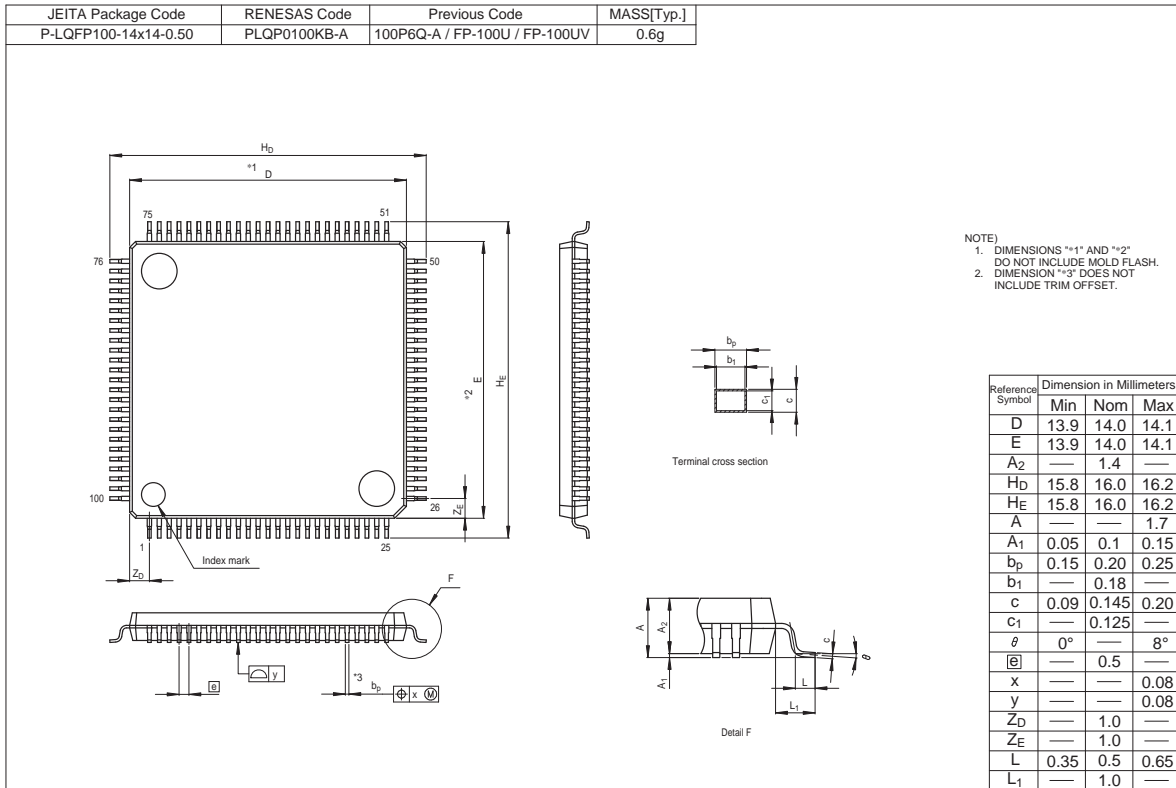

Figure B 100-Pin LQFP (PLQP0100KB-A) Package Dimensions

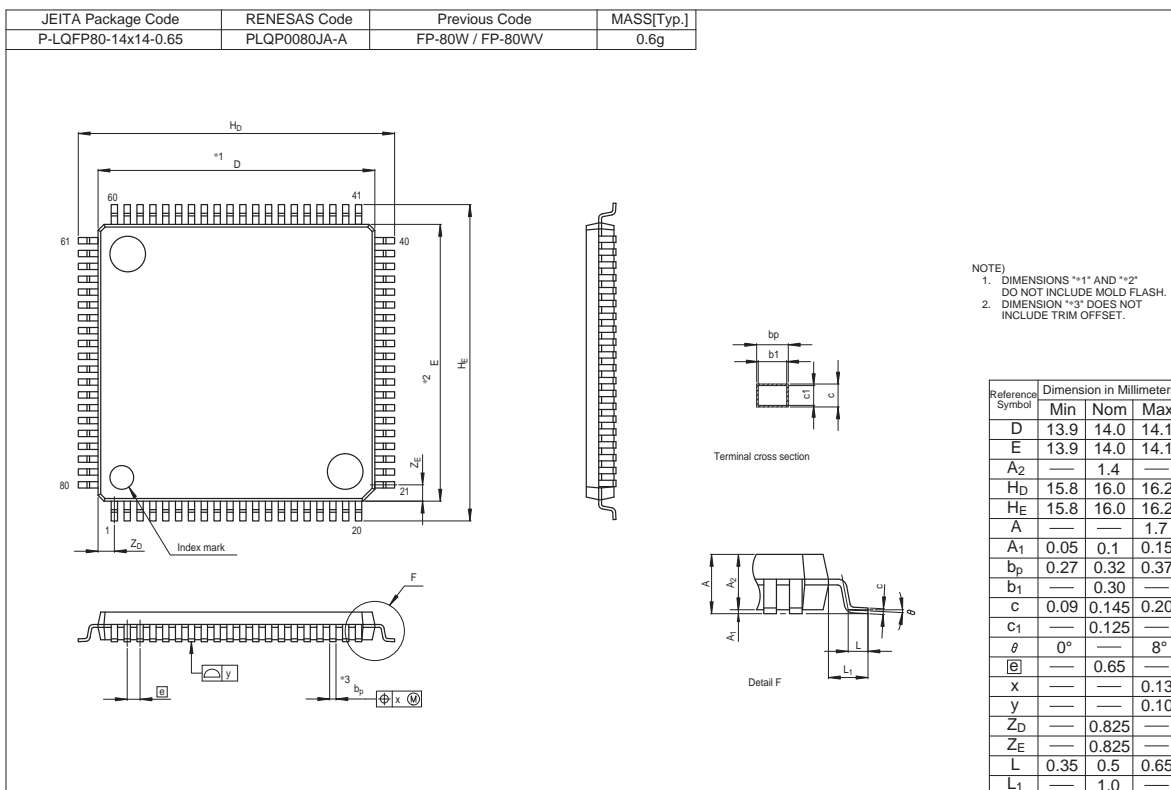

Figure C 80-Pin LQFP (PLQP0080JA-A) Package Dimensions

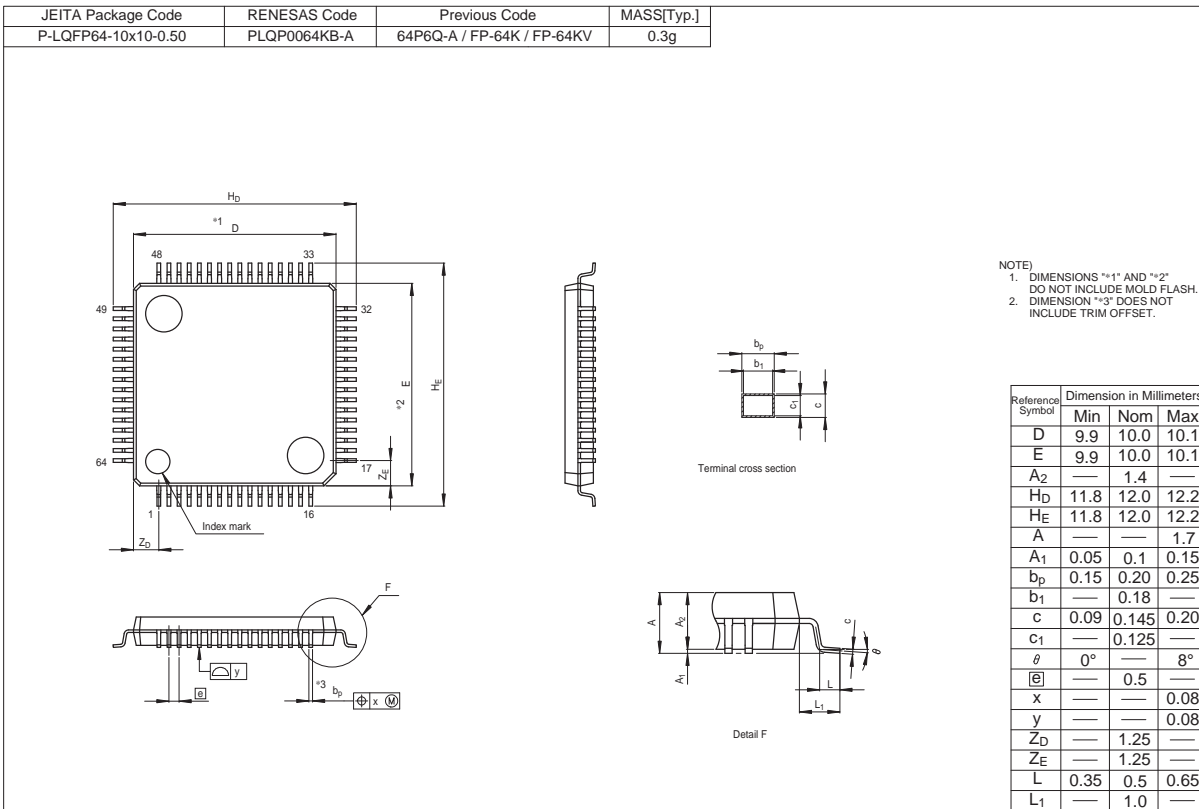

Figure D 64-Pin LQFP (PLQP0064KB-A) Package Dimensions

REVISION HISTORY	RX62T Group Datasheet
------------------	-----------------------

Rev.	Date	Description	
		Page	Summary
1.00	Apr 20, 2011	—	First edition issued

All trademarks and registered trademarks are the property of their respective owners.

## General Precautions in the Handling of MPU/MCU Products

The following usage notes are applicable to all MPU/MCU products from Renesas. For detailed usage notes on the products covered by this manual, refer to the relevant sections of the manual. If the descriptions under General Precautions in the Handling of MPU/MCU Products and in the body of the manual differ from each other, the description in the body of the manual takes precedence.

### 1. Handling of Unused Pins

Handle unused pins in accord with the directions given under Handling of Unused Pins in the manual.

- The input pins of CMOS products are generally in the high-impedance state. In operation with an unused pin in the open-circuit state, extra electromagnetic noise is induced in the vicinity of LSI, an associated shoot-through current flows internally, and malfunctions occur due to the false recognition of the pin state as an input signal become possible. Unused pins should be handled as described under Handling of Unused Pins in the manual.

### 2. Processing at Power-on

The state of the product is undefined at the moment when power is supplied.

- The states of internal circuits in the LSI are indeterminate and the states of register settings and pins are undefined at the moment when power is supplied.  
In a finished product where the reset signal is applied to the external reset pin, the states of pins are not guaranteed from the moment when power is supplied until the reset process is completed.  
In a similar way, the states of pins in a product that is reset by an on-chip power-on reset function are not guaranteed from the moment when power is supplied until the power reaches the level at which resetting has been specified.

### 3. Prohibition of Access to Reserved Addresses

Access to reserved addresses is prohibited.

- The reserved addresses are provided for the possible future expansion of functions. Do not access these addresses; the correct operation of LSI is not guaranteed if they are accessed.

### 4. Clock Signals

After applying a reset, only release the reset line after the operating clock signal has become stable. When switching the clock signal during program execution, wait until the target clock signal has stabilized.

- When the clock signal is generated with an external resonator (or from an external oscillator) during a reset, ensure that the reset line is only released after full stabilization of the clock signal. Moreover, when switching to a clock signal produced with an external resonator (or by an external oscillator) while program execution is in progress, wait until the target clock signal is stable.

### 5. Differences between Products

Before changing from one product to another, i.e. to one with a different part number, confirm that the change will not lead to problems.

- The characteristics of MPU/MCU in the same group but having different part numbers may differ because of the differences in internal memory capacity and layout pattern. When changing to products of different part numbers, implement a system-evaluation test for each of the products.

## Notice

1. All information included in this document is current as of the date this document is issued. Such information, however, is subject to change without any prior notice. Before purchasing or using any Renesas Electronics products listed herein, please confirm the latest product information with a Renesas Electronics sales office. Also, please pay regular and careful attention to additional and different information to be disclosed by Renesas Electronics such as that disclosed through our website.
  2. Renesas Electronics does not assume any liability for infringement of patents, copyrights, or other intellectual property rights of third parties by or arising from the use of Renesas Electronics products or technical information described in this document. No license, express, implied or otherwise, is granted hereby under any patents, copyrights or other intellectual property rights of Renesas Electronics or others.
  3. You should not alter, modify, copy, or otherwise misappropriate any Renesas Electronics product, whether in whole or in part.
  4. Descriptions of circuits, software and other related information in this document are provided only to illustrate the operation of semiconductor products and application examples. You are fully responsible for the incorporation of these circuits, software, and information in the design of your equipment. Renesas Electronics assumes no responsibility for any losses incurred by you or third parties arising from the use of these circuits, software, or information.
  5. When exporting the products or technology described in this document, you should comply with the applicable export control laws and regulations and follow the procedures required by such laws and regulations. You should not use Renesas Electronics products or the technology described in this document for any purpose relating to military applications or use by the military, including but not limited to the development of weapons of mass destruction. Renesas Electronics products and technology may not be used for or incorporated into any products or systems whose manufacture, use, or sale is prohibited under any applicable domestic or foreign laws or regulations.
  6. Renesas Electronics has used reasonable care in preparing the information included in this document, but Renesas Electronics does not warrant that such information is error free. Renesas Electronics assumes no liability whatsoever for any damages incurred by you resulting from errors in or omissions from the information included herein.
  7. Renesas Electronics products are classified according to the following three quality grades: "Standard", "High Quality", and "Specific". The recommended applications for each Renesas Electronics product depends on the product's quality grade, as indicated below. You must check the quality grade of each Renesas Electronics product before using it in a particular application. You may not use any Renesas Electronics product for any application categorized as "Specific" without the prior written consent of Renesas Electronics. Further, you may not use any Renesas Electronics product for any application for which it is not intended without the prior written consent of Renesas Electronics. Renesas Electronics shall not be in any way liable for any damages or losses incurred by you or third parties arising from the use of any Renesas Electronics product for an application categorized as "Specific" or for which the product is not intended where you have failed to obtain the prior written consent of Renesas Electronics. The quality grade of each Renesas Electronics product is "Standard" unless otherwise expressly specified in a Renesas Electronics data sheets or data books, etc.  
"Standard": Computers; office equipment; communications equipment; test and measurement equipment; audio and visual equipment; home electronic appliances; machine tools; personal electronic equipment; and industrial robots.  
"High Quality": Transportation equipment (automobiles, trains, ships, etc.); traffic control systems; anti-disaster systems; anti-crime systems; safety equipment; and medical equipment not specifically designed for life support.  
"Specific": Aircraft; aerospace equipment; submersible repeaters; nuclear reactor control systems; medical equipment or systems for life support (e.g. artificial life support devices or systems), surgical implants, or healthcare intervention (e.g. excision, etc.), and any other applications or purposes that pose a direct threat to human life.
  8. You should use the Renesas Electronics products described in this document within the range specified by Renesas Electronics, especially with respect to the maximum rating, operating supply voltage range, movement power voltage range, heat radiation characteristics, installation and other product characteristics. Renesas Electronics shall have no liability for malfunctions or damages arising out of the use of Renesas Electronics products beyond such specified ranges.
  9. Although Renesas Electronics endeavors to improve the quality and reliability of its products, semiconductor products have specific characteristics such as the occurrence of failure at a certain rate and malfunctions under certain use conditions. Further, Renesas Electronics products are not subject to radiation resistance design. Please be sure to implement safety measures to guard them against the possibility of physical injury, and injury or damage caused by fire in the event of the failure of a Renesas Electronics product, such as safety design for hardware and software including but not limited to redundancy, fire control and malfunction prevention, appropriate treatment for aging degradation or any other appropriate measures. Because the evaluation of microcomputer software alone is very difficult, please evaluate the safety of the final products or system manufactured by you.
  10. Please contact a Renesas Electronics sales office for details as to environmental matters such as the environmental compatibility of each Renesas Electronics product. Please use Renesas Electronics products in compliance with all applicable laws and regulations that regulate the inclusion or use of controlled substances, including without limitation, the EU RoHS Directive. Renesas Electronics assumes no liability for damages or losses occurring as a result of your noncompliance with applicable laws and regulations.
  11. This document may not be reproduced or duplicated, in any form, in whole or in part, without prior written consent of Renesas Electronics.
  12. Please contact a Renesas Electronics sales office if you have any questions regarding the information contained in this document or Renesas Electronics products, or if you have any other inquiries.
- (Note 1) "Renesas Electronics" as used in this document means Renesas Electronics Corporation and also includes its majority-owned subsidiaries.  
(Note 2) "Renesas Electronics product(s)" means any product developed or manufactured by or for Renesas Electronics.



### SALES OFFICES

Renesas Electronics Corporation

<http://www.renesas.com>

Refer to "<http://www.renesas.com/>" for the latest and detailed information.

#### Renesas Electronics America Inc.

2880 Scott Boulevard Santa Clara, CA 95050-2554, U.S.A.  
Tel: +1-408-588-6000, Fax: +1-408-588-6130

#### Renesas Electronics Canada Limited

1101 Nicholson Road, Newmarket, Ontario L3Y 9C3, Canada  
Tel: +1-905-898-5441, Fax: +1-905-898-3220

#### Renesas Electronics Europe Limited

Dukes Meadow, Millboard Road, Bourne End, Buckinghamshire, SL8 5FH, U.K  
Tel: +44-1628-585-100, Fax: +44-1628-585-900

#### Renesas Electronics Europe GmbH

Arcadiastrasse 10, 40472 Düsseldorf, Germany  
Tel: +49-211-65030, Fax: +49-211-6503-1327

#### Renesas Electronics (China) Co., Ltd.

7th Floor, Quantum Plaza, No.27 ZhiChunLu Haidian District, Beijing 100083, P.R.China  
Tel: +86-10-8235-1155, Fax: +86-10-8235-7679

#### Renesas Electronics (Shanghai) Co., Ltd.

Unit 204, 205, AZIA Center, No.1233 Lujiazui Ring Rd., Pudong District, Shanghai 200120, China  
Tel: +86-21-5877-1818, Fax: +86-21-6887-7858 / -7898

#### Renesas Electronics Hong Kong Limited

Unit 1601-1613, 16/F., Tower 2, Grand Century Place, 193 Prince Edward Road West, Mongkok, Kowloon, Hong Kong  
Tel: +852-2886-9318, Fax: +852-2886-9022/9044

#### Renesas Electronics Taiwan Co., Ltd.

13F, No. 363, Fu Shing North Road, Taipei, Taiwan  
Tel: +886-2-8175-9600, Fax: +886-2-8175-9670

#### Renesas Electronics Singapore Pte. Ltd.

1 HarbourFront Avenue, #06-10, Keppel Bay Tower, Singapore 098632  
Tel: +65-6213-0200, Fax: +65-6278-8001

#### Renesas Electronics Malaysia Sdn.Bhd.

Unit 906, Block B, Menara Amcorp, Amcorp Trade Centre, No. 18, Jln Persiaran Barat, 46050 Petaling Jaya, Selangor Darul Ehsan, Malaysia  
Tel: +60-3-7955-9390, Fax: +60-3-7955-9510

#### Renesas Electronics Korea Co., Ltd.

11F., Samik Laved' or Bldg., 720-2 Yeoksam-Dong, Kangnam-Ku, Seoul 135-080, Korea  
Tel: +82-2-558-3737, Fax: +82-2-558-5141