

January 30, 1998

TEL:805-498-2111 FAX:805-498-3804 WEB:http://www.semtech.com

## DESCRIPTION

The SC1766 fast charge controller IC is designed for intelligent charging of NiMH or NiCd batteries without overcharging. It detects a voltage drop ( $-\Delta V$ ) occurring in the final stage of a fast charging cycle and correspondingly controls the charging current. Fast charge can also be cut off by a peak voltage timer ( $0\Delta V$ ).

The detection of  $-\Delta V$  is a very reliable method to terminate fast charging for NiMH and NiCd batteries. The SC1766 uses  $-\Delta V$  detection as one of the primary decisions for fast charge cut-off. The  $-\Delta V$  value of the SC1766 is as small as 4mV per cell, particularly suitable for NiMH as well as NiCd batteries. The peak voltage timer is particularly useful when the voltage drop at the end of charge for some batteries, e.g. NiMH cells, is not pronounced enough for reliable detection. An adjustable safety timer (3 settings) is used as a backup termination method. Provisions are made with the SC1766 to prevent fast charge under temperature fault conditions. Two LED outputs are used to indicate the charging status. Another flash LED output can be used alone to indicate charge status.

AC mode allows the battery to drive its loads while being charged. Test mode is provided to dramatically reduce production test time.

## APPLICATIONS

Battery chargers for:

- Mobile phones
- Notebook and laptop personal computers
- Portable power tools and toys
- Portable communications equipment
- Portable video and stereo equipment

## FEATURES

- Reliable fast charge control of NiMH/NiCd batteries
- Fast charge termination by:
  - 1 Accurate  $-\Delta V$  detection level -0.25% with respect to peak value
  - 2 Peak voltage timer ( $0\Delta V$ )
- Adjustable fast charge safety timer
- Protection against temperature fault
- Protection against short-circuited and open batteries
- Wide operation voltage range of 9V to 18V, no extra regulator needed
- Large battery voltage detection range of 0.65V to 3.7V
- LED drivers to indicate charge status or fault conditions
- Voltage reference output
- Quick and easy testing for production
- Space saving 8-pin and 14-pin SO packages

## ORDERING INFORMATION

DEVICE <sup>(1)</sup>	PACKAGE
SC1766CS08	SO-8
SC1766CS14	SO-14

Note:

(1) Add suffix 'TR' for tape and reel.

## ABSOLUTE MAXIMUM RATINGS

Parameter	Symbol	Maximum	Units
Supply Voltage	$V_{CC}$	18	V
DC Voltage Applied to any Pin		18	V
Sink Current of $V_{OUT}$ pin, LED pin, and FLASH pin		20	mA
Operating Temperature Range	$T_A$	0 to 70	°C
Storage Temperature Range	$T_{STG}$	-65 to 150	°C

January 30, 1998

**ELECTRICAL CHARACTERISTICS**

 Unless otherwise specified,  $T_A = 25^\circ\text{C}$ ,  $V_{IN} = 12.5\text{V}$ 

Parameter	Symbol	Min	Typ	Max	Units
Supply Voltage	$V_{DD}$	9		18	V
Supply Current	$I_{DD}$			1.5	mA
$-\Delta V$ detection level w.r.t. peak value			-0.25		%
Voltage protection limits battery low battery high	$V_{BT}$	0.50 3.30	0.65 3.70	0.80 3.90	V
Input impedance of TIMER pin	$Z_{TIMER}$	100			k $\Omega$
Input impedance of MODE pin	$Z_{MODE}$	100			k $\Omega$
Output resistance of LED pin fast charge trickle charge	$R_{LED}$	1	25		M $\Omega$ $\Omega$
Output resistance of $V_{OUT}$ pin fast charge trickle charge	$R_{VOUT}$	1	25		$\Omega$ M $\Omega$
FLASH pin output resistance at fast charge frequency duty cycle	$R_{FLASH}$		25 1 50		$\Omega$ Hz %
Reference voltage source current	$V_{REF}$	1.5	5.85		V mA
Temperature fault voltage limits as fraction of $V_{REF}$ under-temperature over-temperature	$\alpha_{NTCL}$	0.60 0.15	0.70 0.20	0.80 0.25	$V_{REF}$

**PIN CONFIGURATIONS**

VBT □	1	8 □	$V_{REF}$	GND □	1	14 □	GND
GND □	2	7 □	$V_{DD}$	TIMER □	2	13 □	NC
TIMER □	3	6 □	$V_{OUT}$	MODE □	3	12 □	VBT
MODE □	4	5 □	LED	LED □	4	11 □	NC
				$V_{OUT}$ □	5	10 □	$V_{REF}$
				NC □	6	9 □	VNTC
				FLASH □	7	8 □	$V_{DD}$

  

<b>PIN DESCRIPTIONS</b>		$V_{REF}$	Voltage reference output.
$V_{DD}$	Supply voltage input.	LED	Output, for LED indicator.
GND	Ground.	$V_{OUT}$	Output, for LED indicator.
$V_{BT}$	Input, to sense battery voltage.	FLASH	Output, for LED indicator (14-pin only.)
MODE	Input, to set IC operation mode.	VNTC	Input, for temperature protection (14 pin only).
TIMER	Input, for safety timer control.		

January 30, 1998

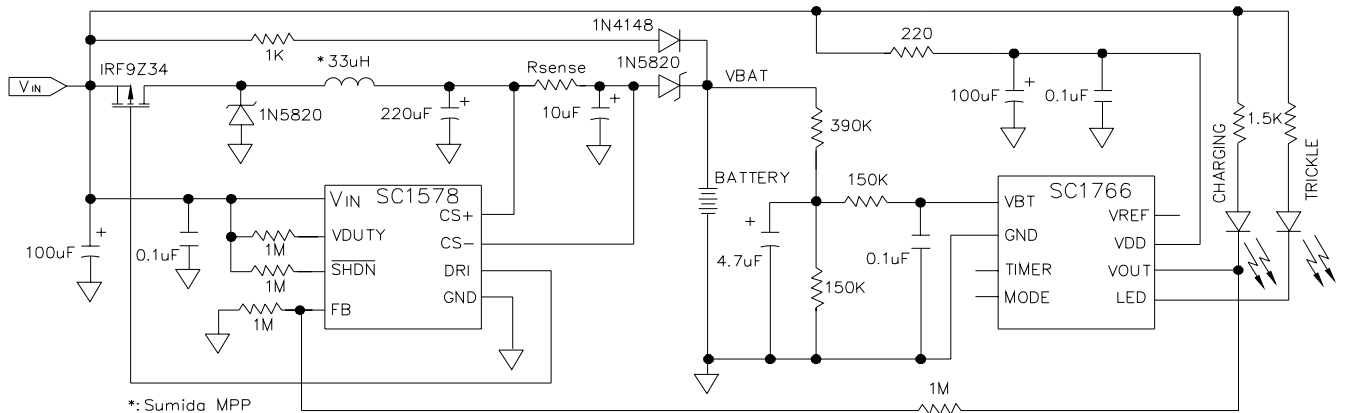
**TYPICAL APPLICATIONS**
**Step-Down High-Side Current Sense Battery Charger**

NOTE: RSENSE = 0.1 ohm, CHARGE CURRENT = 0.5A ±10%,  $V_{IN} > V_{BAT} + 3.5V$   
 RSENSE = 0.05 ohm, CHARGE CURRENT = 1.0A ±10%,  $V_{IN} > V_{BAT} + 4.0V$   
 RSENSE = 0.033 ohm, CHARGE CURRENT = 1.5A ±10%,  $V_{IN} > V_{BAT} + 4.5V$   
 EFFICIENCY > 90%, MEASURED AT CS- NODE

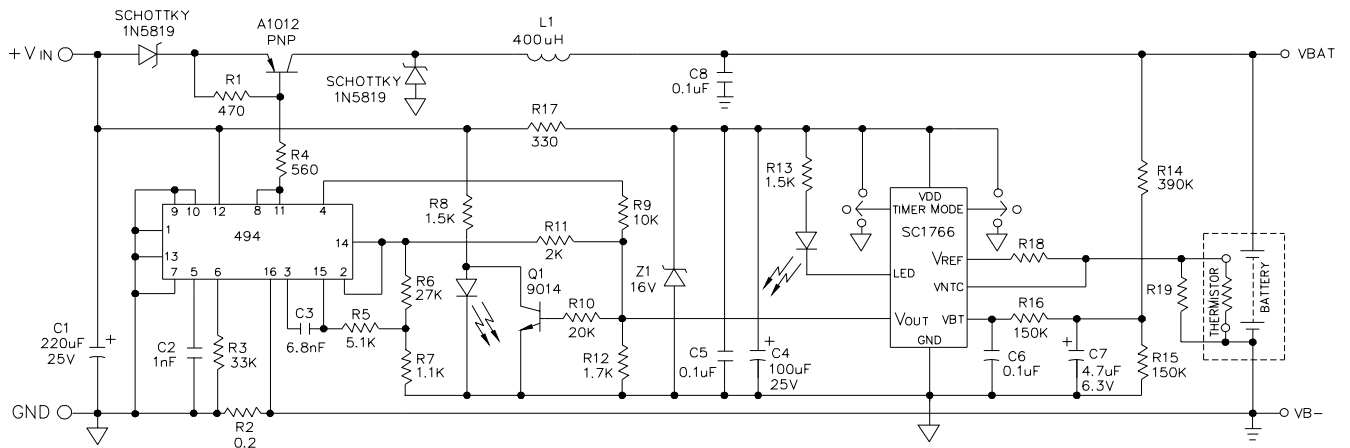
**Step-Down Rechargeable Battery Charger**

NOTE:  $+V_{IN}$  should be higher than 10V. Z1 is required when  $+V_{IN}$  exceeds 18V. Fast charge current is approximately 1A, adjustable through R7. Trickle charge current is adjustable through R12.

January 30, 1998

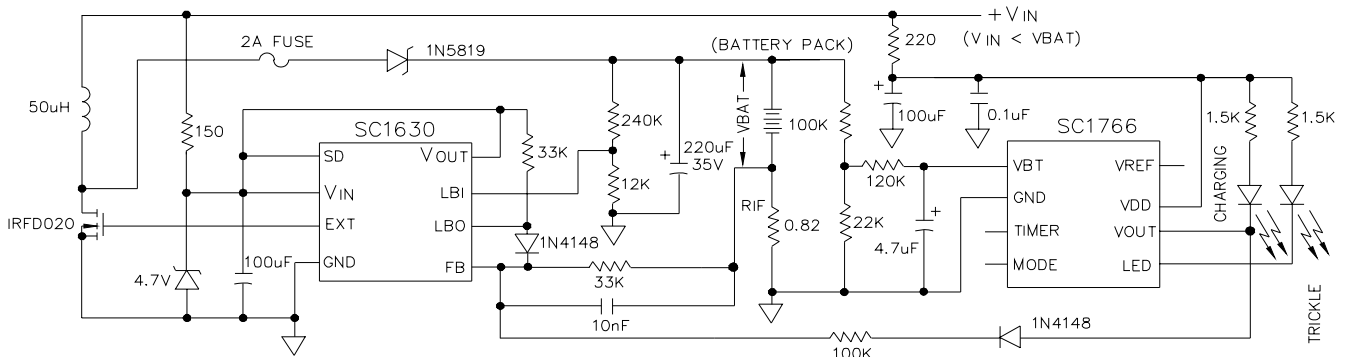
**TYPICAL APPLICATIONS (cont.)**
**Step-Up Rechargeable Battery Charger**

- \*\* CHARGING CURRENT = 0.8A, AUTO CUT-OFF AT 0.25% - DELTA-V POINT AND FAULT CONDITIONS (RIF SETS THE CHARGING CURRENT).
- \*\*  $V_{IN}$  MUST BE LOWER THAN  $V_{BAT}$ .
- \*\* SHORT CIRCUIT CONDITION IS PROTECTED WITH A 2A FUSE.

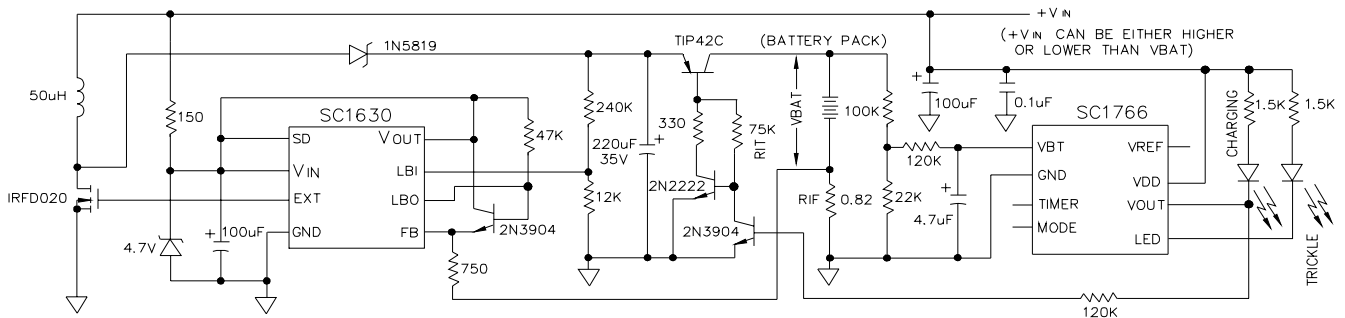
**Step-Up/Down Rechargeable Battery Charger**

- \*\* FAST CHARGE CURRENT = 0.8A @  $V_{IN} < V_{BAT}$ , =  $(V_{IN} - V_{BAT} - 0.5)/0.82$  @  $V_{IN} > V_{BAT}$ .
- TRICKLE CHARGE CURRENT = 30mA (RIF SETS FAST CHARGE CURRENT, RIT SETS TRICKLE CHARGE CURRENT).
- \*\* TYPICAL EFFICIENCY = 75%
- \*\* WITH SHORT CIRCUIT PROTECTION.

January 30, 1998

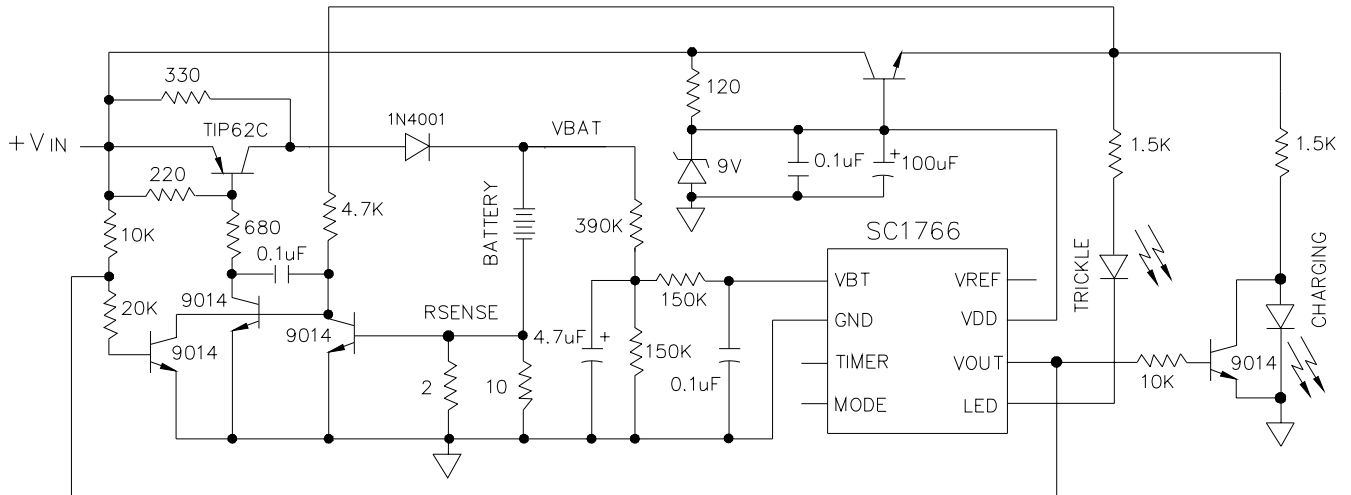
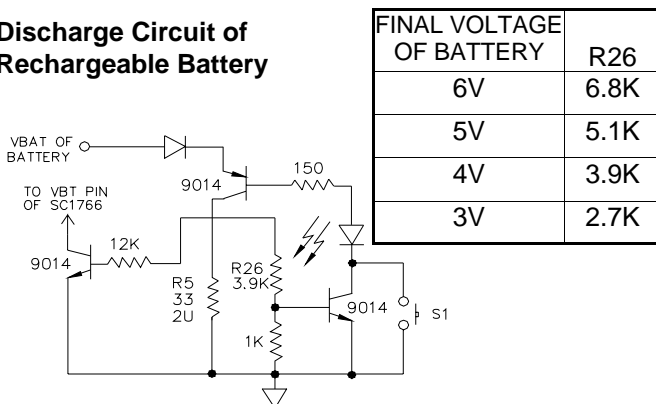
**TYPICAL APPLICATIONS (cont.)**
**Step Down Low-Side Current Sense Battery Charger**

**Discharge Circuit of Rechargeable Battery**

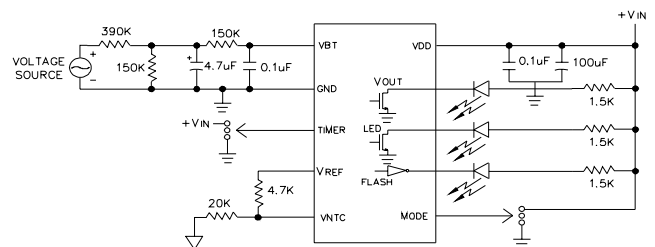
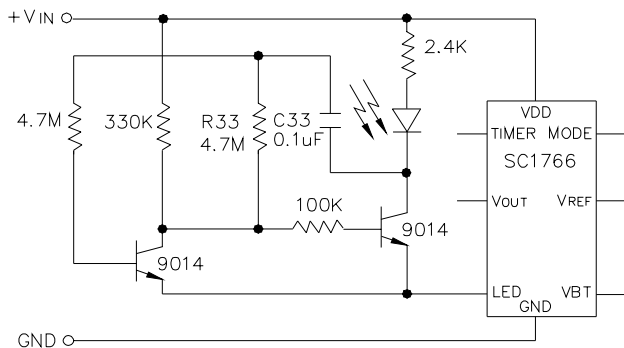
NOTE: The final voltage of battery is determined by R26.  
Discharge current is decided by R5. S1: Push to initiate discharge.

**Test Circuit**

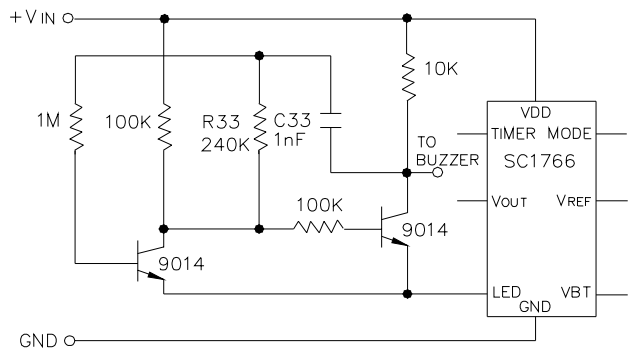
**Flashing-LED Circuit for Trickle Mode**

NOTE: Frequency (about 1Hz) is determined by R33 and C33.  
LED will flash when LED pin goes low.

**Buzzer Circuit for Trickle Charge Mode**

NOTE: Frequency (about 1Hz) is determined by R33 and C33.  
Buzzer will be activated when LED pin goes low.

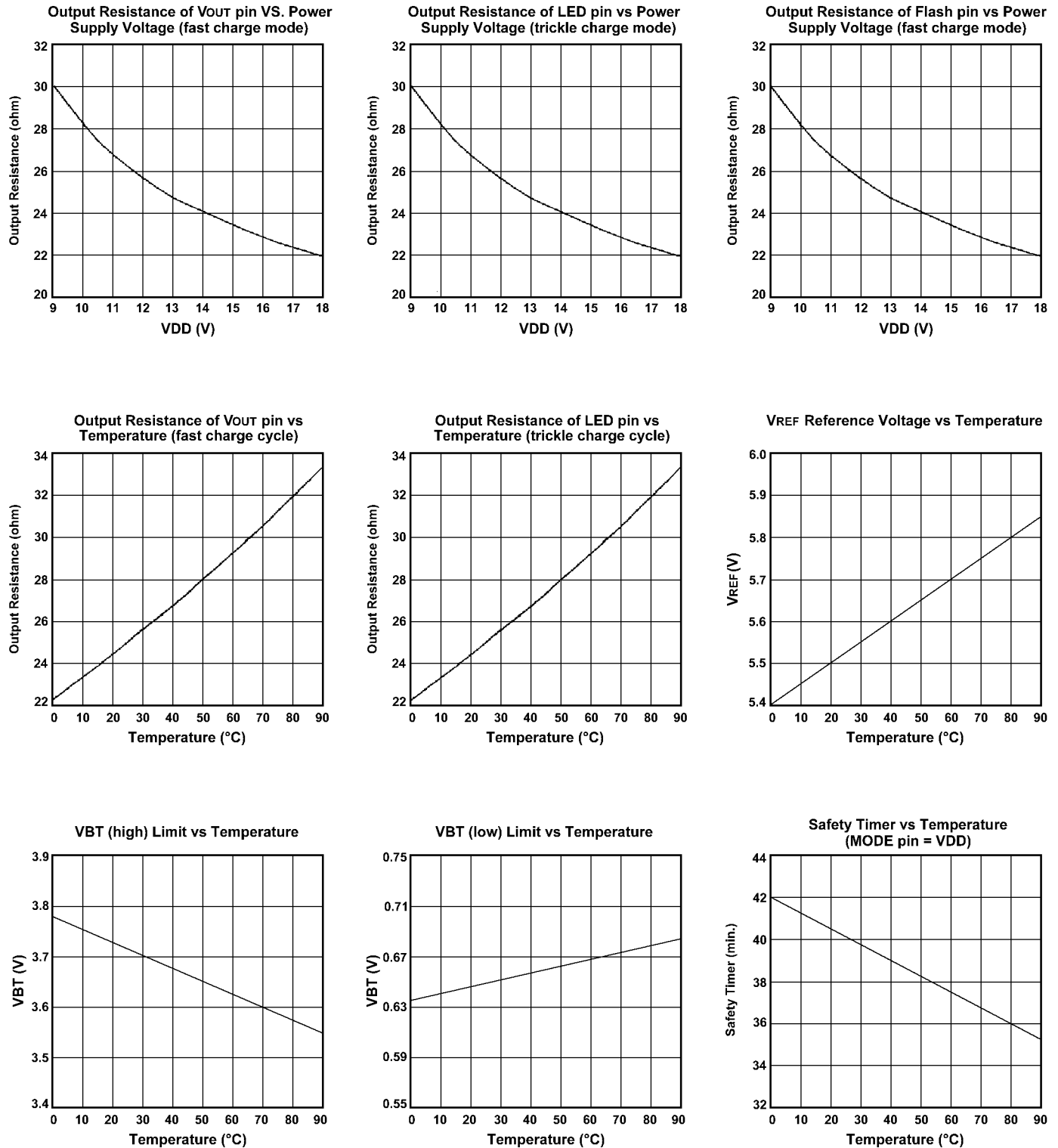
January 30, 1998

**TYPICAL PERFORMANCE CHARACTERISTICS**

January 30, 1998

## PRINCIPLES OF OPERATION

### Battery Properties

The basic principle of rechargeable battery systems, including NiMH and NiCd cells, is that the processes of charge and discharge are reversible. The charge characteristics of NiMH and NiCd cells look similar in that 1) the cell voltage at the end of charge drops and 2) the cell temperature increases rapidly near the end of charge. The figure below shows the charge voltage and charge temperature characteristics of NiMH and NiCd cells. Notice that the cell voltage decline of NiMH cells at the end of charge is less pronounced than for NiCd cells.

Fast battery chargers are available where recharging

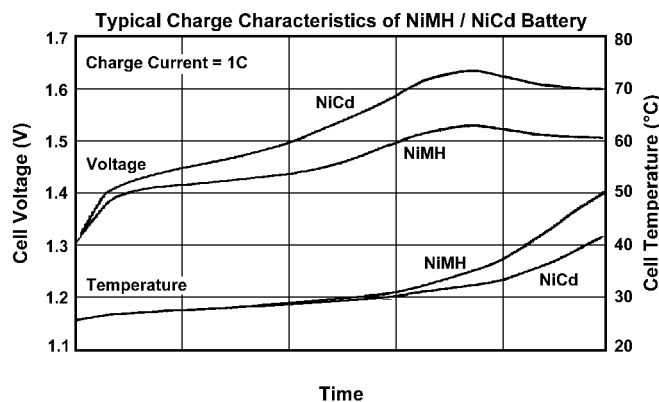

takes only 1 hour or less with a simple control circuit. One main purpose of the control circuit is to terminate the fast charge process to prevent the temperature and internal pressure of the battery cell from building to a damaging level which degrades or even destroys the battery cell.

The SC1766 is a battery fast charge controller IC that utilizes the following methods to terminate the fast charge process for NiMH or NiCd battery cells:

- 1 Negative delta voltage cut-off ( $-\Delta V$ ),
- 2 Peak voltage timer cut-off ( $0\Delta V$ ),
- 3 Maximum temperature cut-off (TCO),
- 4 Maximum voltage cut-off (VCO),
- 5 Safety timer cut-off.

The principle of operation of the SC1766 is described in the following section.

### SC1766 Operation

When power is first applied to the charge system, consisting of rechargeable battery cells, charge current source, the SC1766 and its associated external circuit, all internal digital circuit blocks of the SC1766 are reset by internal power-on-reset circuitry. The internal control

unit then checks the battery condition to prevent fast charge from taking place under battery fault conditions, i.e. cell voltage fault ( $V_{BT} < 0.65V$  or  $V_{BT} > 3.7V$ ) or cell temperature fault ( $\alpha NTC > \alpha NTCL$  or  $\alpha NTC < \alpha NTCH$  for the 14-pin version). Temperature fault limits corresponding to  $\alpha NTCL$  and  $\alpha NTCH$  are determined by an external thermistor divider circuit as included in the typical application circuit. After the battery passes condition fault checks, the  $V_{OUT}$  pin goes to low to start fast charge while the initial timer and safety timer of the SC1766 start counting. Both the negative delta voltage detector and the peak voltage timer, however, are disabled until the initial stage of a charge cycle elapses.

The SC1766 constantly monitors the voltage at the VBT pin, which rises as battery cells are being fast-charged until the battery full condition is nearly approached. The battery temperature is also constantly sensed to guard against abnormal temperature situations. The  $V_{OUT}$  pin will be pulled high by an external pull-up device and the fast charge process will be switched to trickle charge when one of the following situations is encountered:

- A negative delta voltage of 0.25% at the VBT pin is detected compared to its peak value ( $-\Delta V$ ),
- The battery voltage stays at its peak value for the duration determined by the peak voltage timer setting ( $0\Delta V$ ),
- The VBT pin voltage exceeds the "high" battery voltage protection limit (VCO),
- The battery temperature, sensed by the thermistor divider, exceeds the fault temperature range (TCO),
- The selected safety timer period has finished.

### TIMER PIN

The timer pin can be used as follows to select one of the preset safety timer periods and its corresponding periods of initial timer and peak voltage timer:

TIMER pin	Safety timer	Peak V timer	Initial timer
VDD	40 min.	2 min.	1.5 min.
GND	80 min.	4 min.	3 min.
Floating	160 min.	8 min.	3 min.

January 30, 1998

## PRINCIPLES OF OPERATION (cont.)

### MODE PIN

The MODE pin determines the mode in which the IC works:

MODE	Mode	Function
Floating	NORMAL	normal operation
VDD	TEST	1/512 safety timer
GND	AC	$-\Delta V$ detector reset timer stops (not reset)

The SC1766 will operate normally when the MODE pin is left floating (a  $0.1\mu\text{F}$  capacitor is recommended to be tied to the MODE pin if the charge circuit works in a noisy environment). The SC1766 otherwise works in the following ways if the MODE pin is biased either to VDD or to GND:

#### A) AC Mode (MODE pin biased to GND)

In the midst of normal charge operation, where the VBT pin voltage is in the range from 0.8V to 3.5V and the preset safety timer has not run out, the safety timer will stop if the MODE pin is pulled down to GND level. As long as the MODE pin remains low, the VOUT pin stays ON and the LED pin OFF regardless of whether the battery pack voltage declines ( $-\Delta V$  present) or not. AC mode can be activated by pulling the MODE pin to GND to avoid premature battery charge cutoff due to fluctuating charge current source. Switching the MODE pin after the end of the safety timer has no effect on the SC1766 display outputs, i.e., VOUT pin stays OFF while LED pin stays ON.

#### B) TEST Mode (MODE pin biased to VDD)

A unique feature of the SC1766 is that it can be put into a TEST mode by pulling the MODE pin to VDD, allowing verification tests for the SC1766 charge circuit to be performed in a few tens of seconds, extremely valuable in the final phase of production.

When the SC1766 is in TEST mode, all the internal timers are reduced by the following factors when compared to normal operation:

1. Safety timer reduced by a factor of 512 times;
2. Initial timer reduced by a factor of 512 times;
3. Peak timer reduced by a factor of 64 times.

One critical requirement needs to be observed for the

## OPERATION CHART OF THE SC1766

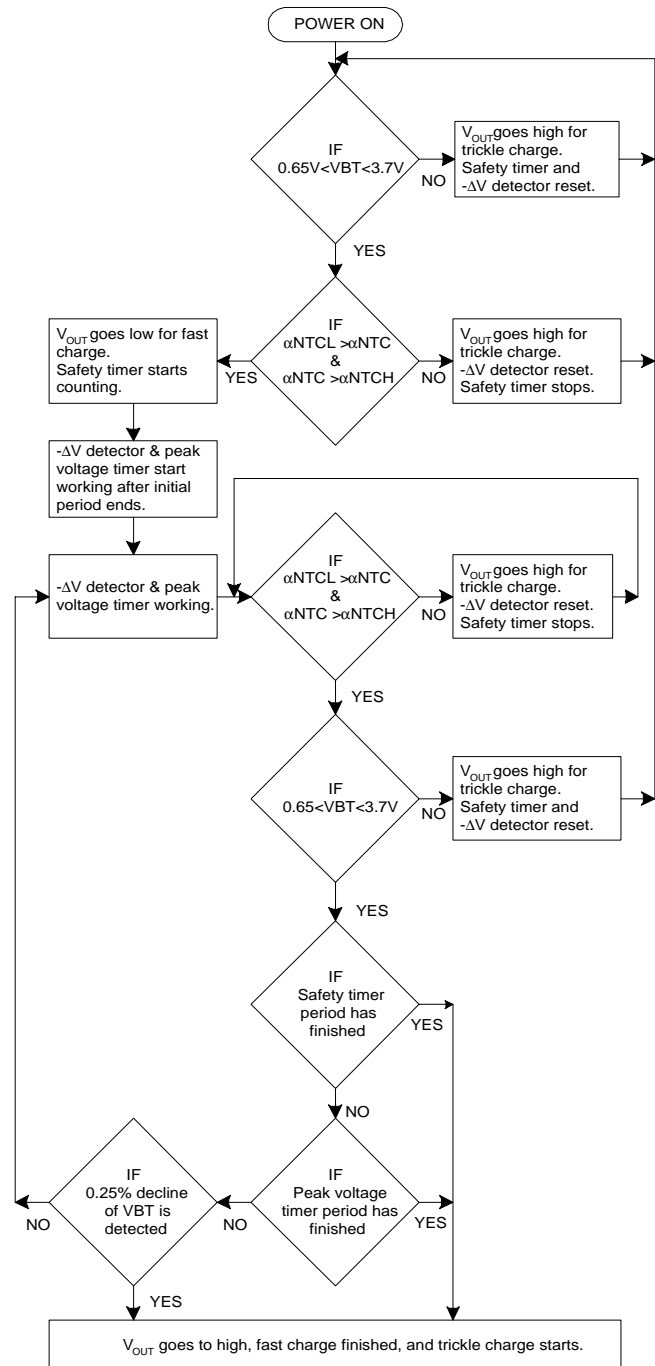



January 30, 1998

**PRINCIPLES OF OPERATION (cont.)**

-ΔV detector of the SC1766 to work properly in test mode, which is that the VBT voltage must be kept between approximately 2.8V to 3.3V, rather than 0.8V to 3.5V in NORMAL mode.

If the TEST mode function is to be utilized in production test, it has to be well planned and included in the circuit design phase to make the voltages of the VBT pin and MODE pins extremely controllable. In addition, an externally controllable TIMER pin can further reduce the test time required for testing the SC1766 in TEST mode.

The figure below shows the timing diagram for externally controlled VBT, TIMER and MODE pin voltages of a recommended SC1766 charge circuit production test scheme, utilizing the TEST mode function. Output waveforms of the VOUT and LED pins (and FLASH pin for 14-pin version) of a properly functioning SC1766 are also shown in the figure. In time segments 4, 8 and 10, the VOUT pin should change from ON to OFF, the LED pin from OFF to ON, and the FLASH pin from ON to flashing output (approximately 4 Hz). For the rest of the time, the VOUT pin should remain ON, the LED pin

OFF, and the FLASH pin ON. The LED indicators work as follows:

	LED PIN	VOUT PIN	FLASH PIN
Fast Charge	OFF	ON	ON
Trickle Charge	ON	OFF	FLASH
VBT Abnormal	OFF	OFF	OFF

The LED pin is used in conjunction with the VOUT pin while the FLASH pin works alone.

Referring to the typical application circuit, the temperature limits beyond where the fast charge is prohibited can be set by choosing values for resistors and the thermistor of the thermistor divider according to the following formula:

$$R18 = 3.57 R_{T1} R_{T2} / (R_{T1} - R_{T2})$$

$$R19 = 10 R_{T1} R_{T2} / (1.218R_{T1} - 11.2R_{T2})$$

RT1: Thermistor resistance at low temp. limit

RT2: Thermistor resistance at high temp. limit

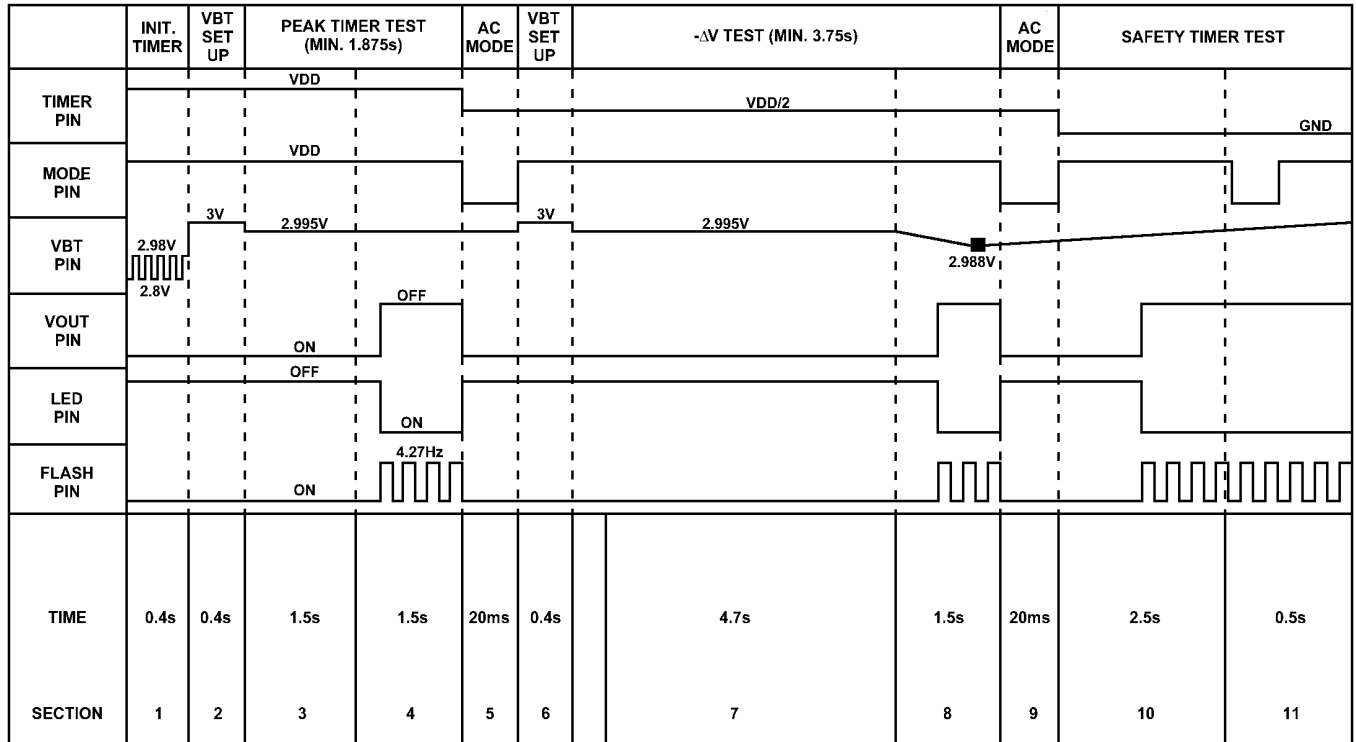
**Timing Diagram of the SC1766 in the Test Mode**

January 30, 1998

## PRINCIPLES OF OPERATION (cont.)

### Battery Voltage Divider

To ensure proper operation of the SC1766, selection of resistor values for the battery voltage divider must meet the following two crucial requirements:

1. When the battery pack is disconnected from the charge circuitry, the voltage of the VBT pin must be higher than 4.0V or lower than 0.5V to put the SC1766 in reset status, where the VOUT and the LED pins become high impedance and the FLASH pin (only for 14-pin version) goes to high level.
2. When the battery pack is connected in normal operation, the VBT pin voltage must remain in the range of 0.8V to 3.5V even when the battery pack voltage reaches its peak when near full charge. Improper setting of the VBT pin voltage may cause the VOUT pin voltage to fluctuate due to SC1766 internal protection scheme.

Take charging an 8-cell battery pack as an example. The highest pack voltage would be 16V when fully charged if the highest voltage of a fully charged battery cell is assumed to be 2V. Since the VBT pin voltage is restricted to no higher than 3.5V, the battery voltage divider ratio must be higher than 3.57 (16V/3.5V - 1). In other words, resistor R14 must be greater than 535kΩ. When the battery pack is disconnected from the charging circuitry the VBT pin voltage must be higher than 4.0V, dictating VBAT node voltage of the charging circuitry to be higher than 17.8V (3.9V x 4.57). Practically, however, the charging circuit supply voltage +VIN should be higher than 18.5 in order to ensure proper operation. In case the supply voltage +VIN can not meet this requirement, the application circuit of the following figure can be adopted to get around this problem.

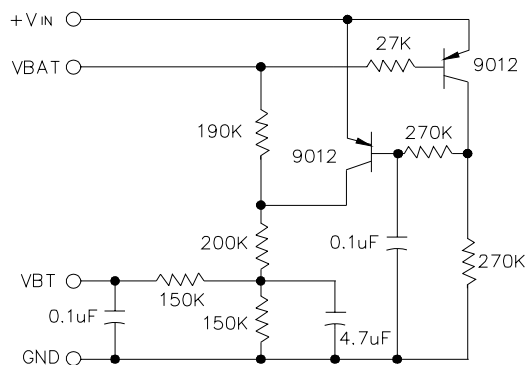

Battery Voltage can be raised to  
VIN = 0.9V when being charged.

### Experimental Results

Experiments have been conducted to verify the SC1766 operation with NiMH and NiCd battery cells of various brands. Actual results shown in the figures below clearly indicate that the negative delta voltage detector and the peak voltage timer of the SC1766 have precisely detected the tiny cell voltage drops or the cell voltage peaks and consequently terminated the fast charge process after batteries are fully charged. The battery cell temperatures were all under safety levels. Note that the fast charge for the NiMH battery in the figure "Charge Characteristics of NiMH Battery" is terminated by the peak voltage timer (0ΔV) while the fast charge for the NiCd battery in the figure "Charge Characteristics of NiCd Battery" is terminated by the -ΔV detector.

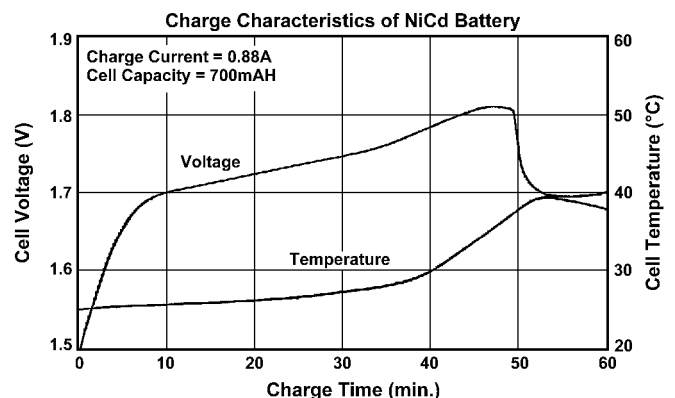
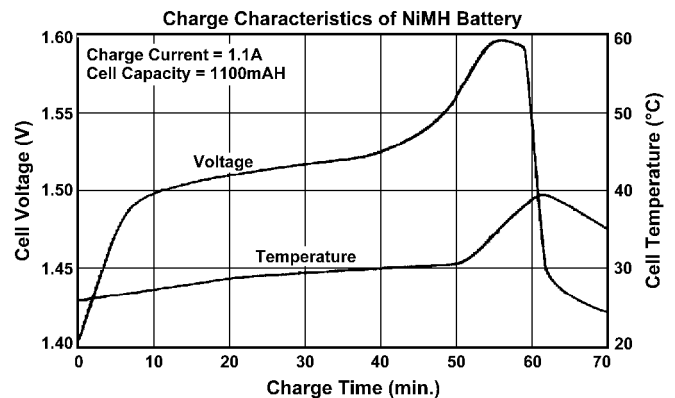

January 30, 1998

**CHARGER CIRCUIT DESIGN TIPS**

1. A stable constant charge current is crucial for reliable precision  $-\Delta V$  detection by the SC1766 since fluctuation of the charge current can cause fluctuation of the battery terminal voltage due to battery internal series resistance, which will likely result in erroneous  $-\Delta V$  detection by a properly functioning SC1766.

2. To prevent damage to the SC1766 from over-voltage, make sure that none of the SC1766 pins see any voltage beyond the supply voltage, which needs to be between +9V and +18V.

3. If the battery charge current is high, e.g. over 1.5A, quality of circuit board layout and wiring connection points become increasingly important in the charger circuit reliability.

4. Since the SC1766 is a CMOS device, care must be taken in handling to avoid possible damage from electrostatic discharge.

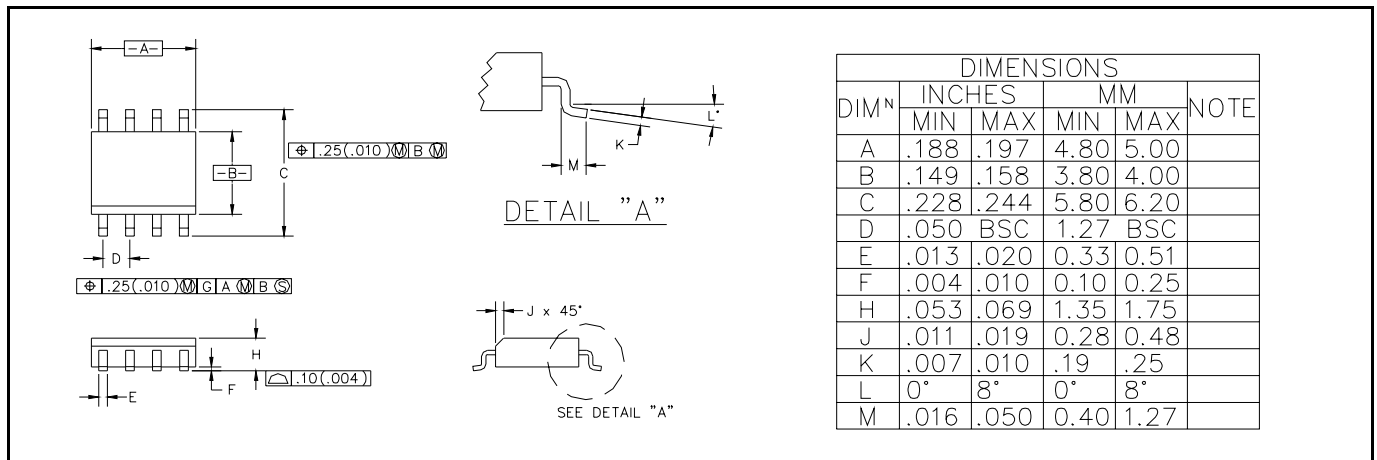
**OUTLINE DRAWING SO-8**

**OUTLINE DRAWING SO-14**
