



Z8 Encore!® Motor Control Flash MCUs

Z8FMC16100 Series

Product Specification

PS024611-0408

Copyright ©2008 by Zilog®, Inc. All rights reserved.
www.zilog.com

 **Warning:** DO NOT USE IN LIFE SUPPORT

LIFE SUPPORT POLICY

ZILOG'S PRODUCTS ARE NOT AUTHORIZED FOR USE AS CRITICAL COMPONENTS IN LIFE SUPPORT DEVICES OR SYSTEMS WITHOUT THE EXPRESS PRIOR WRITTEN APPROVAL OF THE PRESIDENT AND GENERAL COUNSEL OF ZILOG CORPORATION.

As used herein

Life support devices or systems are devices which (a) are intended for surgical implant into the body, or (b) support or sustain life and whose failure to perform when properly used in accordance with instructions for use provided in the labeling can be reasonably expected to result in a significant injury to the user. A critical component is any component in a life support device or system whose failure to perform can be reasonably expected to cause the failure of the life support device or system or to affect its safety or effectiveness.

Document Disclaimer

©2008 by Zilog, Inc. All rights reserved. Information in this publication concerning the devices, applications, or technology described is intended to suggest possible uses and may be superseded. ZILOG, INC. DOES NOT ASSUME LIABILITY FOR OR PROVIDE A REPRESENTATION OF ACCURACY OF THE INFORMATION, DEVICES, OR TECHNOLOGY DESCRIBED IN THIS DOCUMENT. ZILOG ALSO DOES NOT ASSUME LIABILITY FOR INTELLECTUAL PROPERTY INFRINGEMENT RELATED IN ANY MANNER TO USE OF INFORMATION, DEVICES, OR TECHNOLOGY DESCRIBED HEREIN OR OTHERWISE. The information contained within this document has been verified according to the general principles of electrical and mechanical engineering.

Z8, Z8 Encore!, Z8 Encore! XP, Z8 Encore! MC, and eZ80 are trademarks or registered trademarks of Zilog, Inc. All other product or service names are the property of their respective owners.



**ISO 9001:2000
FS 507510**

Zilog products are designed and manufactured under an ISO registered 9001:2000 Quality Management System. For more details, please visit www.zilog.com/quality.

Revision History

Each instance in Revision History reflects a change to this document from its previous revision. For more details, refer to the corresponding pages or appropriate links given in the table below.

Date	Revision Level	Description	Page No
April 2008	11	Updated Ordering Information and Part Number Description section.	298 and 300
January 2008	10	Chapter Electrical Characteristics : updated Table 146 .	265
July 2007	09	Chapter General-Purpose Input/Output : added description for Alternate Function registers. Chapter Pulse Width Modulator : added note under Fault Detection and Protection section. Made Fault1 as active Low. Chapter Reset and Stop Mode Recovery : Updated Table 9 .	35 72 All 27
December 2006	08	Corrected Figure 9 Corrected CMPORST bit Updated Figure 8 and Table 55	69 316 68, 84
November 2006	07	Updated Table 103 Updated Comparator and Op Amp Updated PWM Minimum Pulse Width Filter Table 54 on page 83 Hex Address: F28 section on page 315 Table 138 on page 255 Table 139 on page 256 Added caution on page 33	194 340 79

Table of Contents

Introduction	1
Features	1
Block Diagram	2
CPU and Peripheral Overview	3
Pulse Width Modulator for Motor Control Applications	3
10-Bit Analog-to-Digital Converter	3
Analog Comparator	4
Operational Amplifier	4
General-Purpose Input/Output	4
Flash Controller	4
Random Access Memory	4
UART with LIN and IrDA	4
Serial Peripheral Interface	4
Inter-Integrated Circuit	5
Internal Precision Oscillator	5
Crystal Oscillator	5
Standard Timer	5
Interrupt Controller	5
Reset Controller	5
On-Chip Debugger	5
Signal and Pin Descriptions	7
Pin Configurations	7
Signal Descriptions	8
Pin Characteristics	10
Address Space	11
Register File	11
Program Memory	12
Data Memory	12
Information Area	12
Register File Address Map	15
Reset and Stop Mode Recovery	21
Reset Types	21
System Reset	22

Power-On Reset	23
Voltage Brownout Reset	23
Watchdog Timer Reset	24
External Pin Reset	24
External Reset Indicator	25
On-Chip Debugger Initiated Reset	25
Fault Detect Logic Reset	25
Stop Mode Recovery	25
Stop Mode Recovery Using Watchdog Timer Timeout	26
Stop Mode Recovery Using a GPIO Port Pin Transition	26
PWM $\overline{\text{Fault0}}$ and $\overline{\text{Reset}}$ pin selection	26
Reset Control Register Definitions	27
Reset Status and Control Register	27
Low-Power Modes	29
STOP Mode	29
HALT Mode	29
Peripheral-Level Power Control	30
Power Control Register 0	30
General-Purpose Input/Output	33
GPIO Port Availability By Device	33
Architecture	33
GPIO Alternate Functions	34
GPIO Interrupts	37
GPIO Control Register Definitions	38
Port A-C Address Registers	39
Port A-C Control Registers	40
Port A-C Input Data Registers	46
Port A-C Output Data Registers	47
Interrupt Controller	49
Interrupt and System Exception Vector Listing	49
Architecture	50
Master Interrupt Enable	51
System Exceptions	52
Interrupt Vectors and Priority	52
Interrupt Assertion	52

Software Interrupt Assertion	53
Interrupt Control Register Definitions	53
Interrupt Request 0 Register	53
Interrupt Request 1 Register	54
IRQ0 Enable High and Low Bit Registers	56
IRQ1 Enable High and Low Bit Registers	57
Interrupt Control Register	58
Watchdog Timer	61
Operation	61
Watchdog Timer Refresh	62
Watchdog Timer Timeout Response	62
Watchdog Timer Reload Unlock Sequence	63
Watchdog Timer Reload High and Low Byte Registers	63
Pulse Width Modulator	65
Architecture	65
PWM Option Bits	66
PWM Off State and Output Polarity	67
PWM Channel Pair Enable	67
PWM Reload Event	67
PWM Prescaler	68
PWM Period and Count Resolution	68
PWM Duty Cycle Registers	70
Independent and Complementary PWM Outputs	70
Manual Off-State Control of PWM Output Channels	70
Deadband Insertion	70
Minimum PWM Pulse Width Filter	71
Synchronization of PWM and Analog-to-Digital Converter	71
PWM Timer and Fault Interrupts	72
Fault Detection and Protection	72
PWM Operation in CPU Halt Mode	73
PWM Operation in CPU STOP Mode	73
Observing the State of PWM Output Channels	73
PWM High and Low Byte Registers	73
PWM Reload High and Low Byte Registers	74
PWM 0–2 Duty Cycle High and Low Byte Registers	75

PWM Control 0 Register	76
PWM Control 1 Register	78
PWM Deadband Register	79
PWM Minimum Pulse Width Filter	79
PWM Fault Mask Register	80
PWM Fault Status Register	81
PWM Fault Control Register	83
PWM Input Sample Register	84
PWM Output Control Register	85
Current Sense ADC Trigger Control Register	85
General-Purpose Timer	89
Features	89
Architecture	89
Operation	90
Timer Operating Modes	91
Reading the Timer Count Values	100
Timer 0 High and Low Byte Registers	100
Timer 0 Reload High and Low Byte Registers	102
Timer 0 PWM High and Low Byte Registers	103
Timer 0 Control Registers	104
LIN-UART	109
Architecture	109
Data Format for Standard UART Modes	110
Transmitting Data using Polled Method	111
Transmitting Data using Interrupt-Driven Method	112
Receiving Data using Polled Method	113
Receiving Data using Interrupt-Driven Method	114
Clear To Send Operation	115
External Driver Enable	115
LIN-UART Special Modes	116
MULTIPROCESSOR Mode	116
LIN Protocol Mode	118
LIN-UART Interrupts	122
LIN-UART Baud Rate Generator	125
Noise Filter	125

Architecture	126
Operation	126
LIN-UART Control Register Definitions	128
LIN-UART Transmit Data Register	128
LIN-UART Receive Data Register	128
LIN-UART Status 0 Register	129
LIN-UART Mode Select and Status Register	131
LIN-UART Control 0 Register	133
LIN-UART Control 1 Registers	134
LIN Control Register	137
LIN-UART Address Compare Register	138
LIN-UART Baud Rate High and Low Byte Registers	138
Infrared Encoder/Decoder	143
Architecture	143
Operation	143
Transmitting IrDA Data	144
Receiving IrDA Data	145
Infrared Encoder/Decoder Control Register Definitions	146
Serial Peripheral Interface	147
Architecture	147
Operation	149
SPI Signals	149
SPI Clock Phase and Polarity Control	150
Multimaster Operation	152
Slave Operation	153
Error Detection	153
SPI Interrupts	154
SPI Baud Rate Generator	154
SPI Data Register	155
SPI Control Register	155
SPI Status Register	157
SPI Mode Register	158
SPI Diagnostic State Register	159
SPI Baud Rate High and Low Byte Registers	160

I²C Master/Slave Controller	161
Architecture	161
I ² C Master/Slave Controller Registers	162
Comparison with the Master Mode Only I ² C Controller	163
Operation	164
SDA and SCL Signals	164
I ² C Interrupts	165
Start and Stop Conditions	167
Software Control of I ² C Transactions	167
Master Transactions	167
Slave Transactions	175
I ² C Data Register	182
I ² C Interrupt Status Register	182
I ² C Control Register	184
I ² C Baud Rate High and Low Byte Registers	185
I ² C State Register	186
I ² C Mode Register	190
I ² C Slave Address Register	191
Comparator and Operational Amplifier	193
Comparator Operation	193
Operational Amplifier Operation	194
Interrupts	194
Comparator and Op Amp Control Register	194
Analog-to-Digital Converter	197
Architecture	197
Operation	198
ADC Timing	199
ADC Interrupt	200
ADC Timer 0 Capture	200
Reference Buffer	200
Internal Voltage Reference Generator	200
Calibration and Compensation	201
ADC Control Register 0	201
ADC Raw Data High Byte Register	202
ADC Data High Byte Register	202

ADC Data Low Bits Register	203
Sample Settling Time Register	204
Sample Time Register	204
ADC Clock Prescale Register	205
ADC Timer Capture High Byte Register	206
ADC Timer Capture Low Byte Register	207
Program Memory	209
Information Area	210
Operation	211
Timing Using Flash Frequency Registers	211
Flash Read Protection	212
Flash Write/Erase Protection	212
Byte Programming	213
Page Erase	214
Mass Erase	214
Flash Controller Bypass	215
Flash Controller Behavior in Debug Mode	215
Flash Control Register Definitions	215
Flash Status Register	216
Flash Page Select Register	217
Flash Sector Protect Register	218
Flash Frequency High and Low Byte Registers	218
Option Bits	221
Option Bit Types	221
User Option Bits	221
Trim Option Bits	222
User Option Bit Configuration By Reset	222
Option Bit Address Space	222
Program Memory Address 0000H	222
Program Memory Address 0001H	223
Trim Bit Data Register	225
Trim Bit Address 0001H	225
Trim Bit Address 0002H	226
Trim Bit Address 0003H	227

Oscillator Control	229
Operation	229
System Clock Selection	229
Clock Selection Following System Reset	230
Clock Failure Detection and Recovery for Primary Oscillator	230
Clock Failure Detection and Recovery for WDT Oscillator	231
Oscillator Control Register	231
Oscillator Divide Register	232
On-Chip Oscillator	235
Crystal Oscillator Operation	235
Internal Precision Oscillator	237
Operation	237
On-Chip Debugger	239
Architecture	239
OCD Interface	239
Debug Mode	240
OCD Data Format	241
OCD Auto-Baud Detector/Generator	242
OCD Serial Errors	242
Automatic Reset	243
Break Points	243
OCD CNTR Register	244
On-Chip Debugger Commands	245
OCD Control Register	250
OCD Status Register	252
Baud Reload Register	253
Electrical Characteristics	255
Absolute Maximum Ratings	255
DC Characteristics	256
AC Characteristics	261
On-Chip Peripheral AC and DC Electrical Characteristics	262
General-Purpose Input/Output Port Input Data Sample Timing	268
General-Purpose Input/Output Port Output Timing	269
On-Chip Debugger Timing	270
UART Timing	271

eZ8 CPU Instruction Set	273
Assembly Language Programming Introduction	273
Assembly Language Syntax	274
eZ8 CPU Instruction Notation	275
Condition Codes	277
eZ8 CPU Instruction Classes	278
eZ8 CPU Instruction Summary	282
Flags Register	290
Opcode Maps	293
Packaging	297
Ordering Information	298
Part Number Description	300
Appendix A—Register Tables	301
General Purpose RAM	301
Timer 0	301
Pulse Width Modulator	308
LIN-UART	325
I ² C	328
SPI	331
Analog-to-Digital Converter	333
Oscillator Control	338
Trim Control	339
Comparator and Op Amp	340
Interrupt Controller	341
GPIO Port A	346
GPIO Port B	347
GPIO Port C	349
Reset and Watchdog Timer	351
Flash Memory Controller	353
eZ8 CPU	355
Opcode Maps	356
Index	359
Customer Support	369

Introduction

Zilog's Z8FMC16100 Series Flash MCU is based on Zilog's advanced eZ8 8-bit CPU core and is optimized for motor control applications. It supports control of single and multiphase variable speed motors. Target applications are consumer appliances, HVAC, factory automation, refrigeration, and automotive applications.

Features

The Z8FMC16100 Series Flash MCU features include:

- 20 MHz eZ8 CPU core
- Up to 16 KB Flash program memory
- 512 B register RAM
- Fast 8-channel 10-bit Analog-to-Digital Converter (ADC)
- 12-bit Pulse-Width Modulator (PWM) module with three complementary pairs or six independent PWM outputs with deadband generation and fault trip input
- 16-bit timer with Capture, Compare, and PWM capability
- Analog comparator
- Operational amplifier
- Inter-Integrated Circuit (I²C) controller supports master, slave, and multimaster modes
- Universal Asynchronous Receiver/Transmitter (UART) with interface support for Local Interconnect Network (LIN) and IrDA
- Serial Peripheral Interface (SPI) controller
- Internal Precision Oscillator (IPO)
- On-chip oscillator supports external crystals, ceramic resonators, and clock drivers
- 17 General-Purpose Input/Output (GPIO) pins
- Voltage Brownout/Power-On Reset (VBO/POR)
- Watchdog Timer (WDT) with internal RC oscillator
- On-Chip Debugger (OCD)
- In-circuit serial programming
- Operating at 2.7 V to 3.6 V
- 32-pin packages
- Lead-free packaging
- Standard and extended temperature ranges: 0 °C to 70 °C (S) and –40 °C to 105 °C (E)
- Up to 20 interrupts with configurable priority

Block Diagram

Figure 1 displays the architecture of the Z8FMC16100 Series Flash MCU.

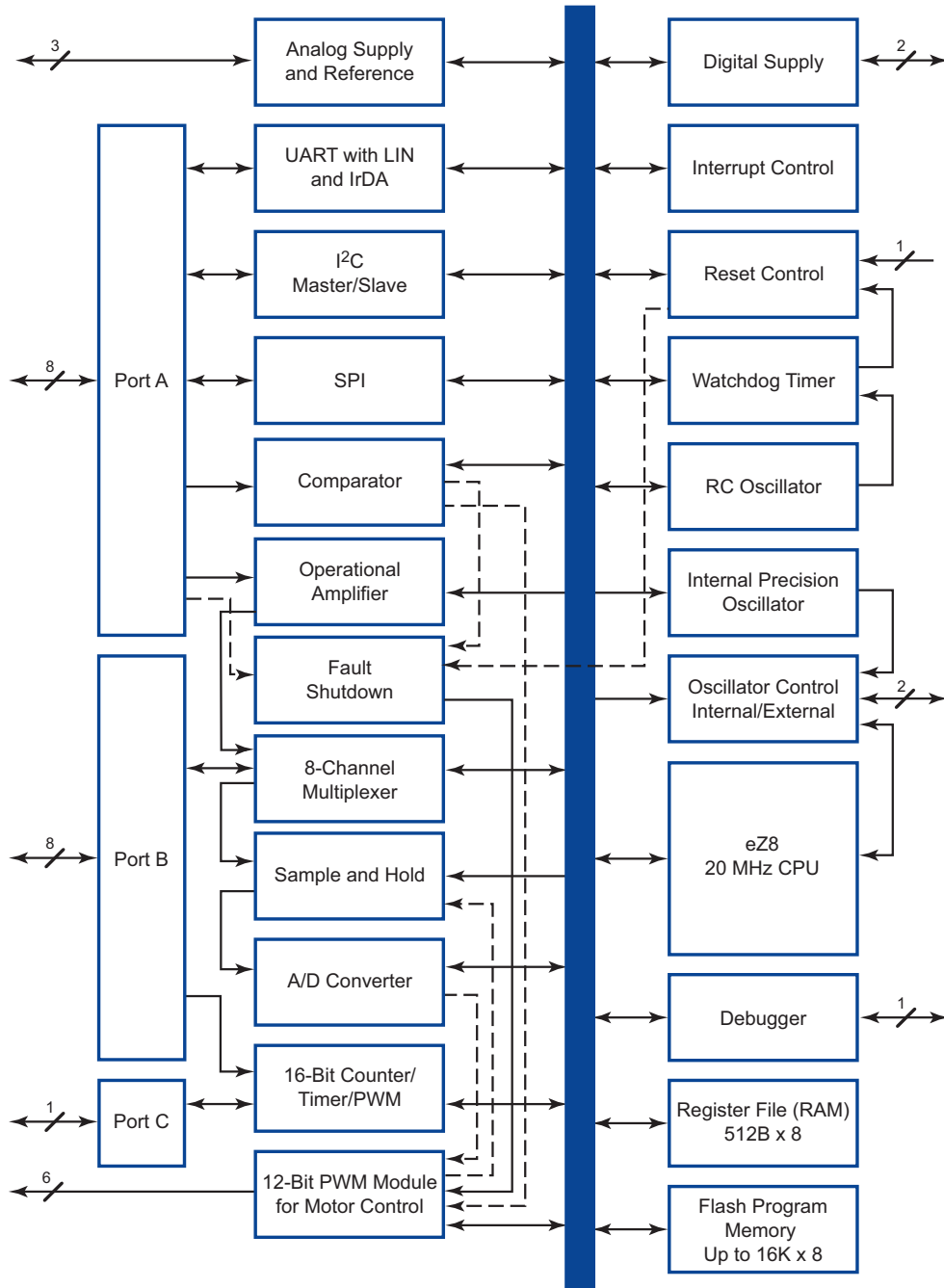

Figure 1. Z8FMC16100 Series Flash MCU Block Diagram

CPU and Peripheral Overview

Zilog's latest 8-bit eZ8 CPU meets the continuing demand for faster and more code-efficient microcontrollers. The eZ8 CPU executes a superset of original Z8[®] instruction set. The eZ8 CPU features include:

- Direct register-to-register architecture allows each register to function as an accumulator, improving execution time, and decreasing the required program memory
- Software stack allows much greater depth in subroutine calls and interrupts than hardware stacks
- Compatible with existing Z8 assembly code
- New instructions improve execution efficiency for code developed using higher-level programming languages, including 'C' language
- Pipelined instruction fetch and execution
- New instructions for improved performance including BIT, BSWAP, BTJ, CPC, LDC, LDCI, LEA, MULT, and SRL
- New instructions support 12-bit linear addressing of the Register File
- Up to 10 MIPS operation
- C-Compiler friendly
- 2-9 clock cycles per instruction

For more details on the eZ8 CPU, refer to *eZ8 CPU User Manual (UM0128)*, available for download at www.zilog.com.

Pulse Width Modulator for Motor Control Applications

To rotate a 3-phase motor three voltage and current signals must be supplied, each 120° shifted from each other. To control a 3-phase motor, the MCU must provide 6 PWM outputs. The Z8FMC16100 Series Flash MCU features a flexible PWM module with three complementary pairs or six independent PWM outputs supporting deadband operation and fault protection trip input. These features provide multiphase control capability for various motor types and ensure safe operation of the motor by providing immediate shutdown of the PWM pins during fault condition.

10-Bit Analog-to-Digital Converter

The Z8FMC16100 Series Flash MCU devices feature up to eight channels of 10-bit analog-to-digital conversion.

Analog Comparator

The Z8FMC16100 Series Flash MCU features an on-chip analog comparator with external input pins.

Operational Amplifier

The Z8FMC16100 Series Flash MCU features a two-input and one-output operational amplifier.

General-Purpose Input/Output

The Z8FMC16100 Series Flash MCU features 17 GPIO pins. Each pin is individually programmable.

Flash Controller

The Flash Controller programs and erases the Flash memory. The Z8FMC16100 Series Flash MCU products contain 16 KB of on-chip Flash memory. A sector protection scheme allows for flexible protection of user code.

Random Access Memory

An internal random access memory (RAM) of 512 B provides storage space for data, variables, and stack operations.

UART with LIN and IrDA

A full-duplex 9-bit UART provides a serial, asynchronous communication and supports the LIN serial communications protocol. The UART communication is full-duplex and capable of handling asynchronous data transfers. The UARTs support 8- and 9-bit data modes, selectable parity, and an efficient bus transceiver Driver Enable signal for controlling a multitransceiver bus, such as RS-485. The LIN bus is a cost-efficient single master, multiple slave organization which supports speed up to 20 Kbps.

Serial Peripheral Interface

The SPI allows the Z8 Encore![®] MCU to exchange data between other peripheral devices such as electrically erasable programmable read-only memory (EEPROM), A/D converters, and ISDN devices. The SPI is a full-duplex, synchronous, character-oriented channel that supports a 4-wire interface.

Inter-Integrated Circuit

The I²C controller makes the Z8 Encore! MCU compatible with the I²C protocol. The I²C controller consists of two bidirectional bus lines, a serial data (SDA) line and a serial clock (SCL) line. The I²C operates as a master and/or slave and supports multimaster bus arbitration.

Internal Precision Oscillator

The IPO provides a stable, accurate time base without the requirement for external components. This reduces system cost in many applications by eliminating the requirement for external crystals or ceramic resonators. The IPO frequency is 5.5296 MHz.

Crystal Oscillator

The on-chip crystal oscillator features programmable gain to support crystals and ceramic resonators ranging from 32 kHz to 20 MHz. The oscillator can also be used with clock drivers.

Standard Timer

The 16-bit reloadable timer can be used for timing/counting events and PWM signal generation. This timer provides a 16-bit programmable reload counter and operate in ONE-SHOT, CONTINUOUS, GATED, CAPTURE, COMPARE, CAPTURE and COMPARE, and PWM modes. This timer can measure velocity from a tachometer wheel or read sensor outputs for rotor position for brushless DC motor commutation. The standard timer can also be used for general-purpose timing and counting operations.

Interrupt Controller

The Z8FMC16100 Series Flash MCU supports 3 levels of programmable interrupt priority. The interrupt sources include internal peripherals, GPIO pins, and system fault detection.

Reset Controller

The Z8FMC16100 Series Flash MCU is reset using the $\overline{\text{RESET}}$ pin, POR, WDT, Stop Mode Recovery, or VBO warning signal.

On-Chip Debugger

The Z8FMC16100 Series Flash MCU features an integrated On-Chip Debugger (OCD). The single-pin OCD interface provides a rich set of debugging capabilities, like reading and writing registers, programming the Flash, setting break points, and executing code. The OCD simplifies code development and allows easy in-circuit programming.

Signal and Pin Descriptions

The Z8FMC16100 Series Flash MCU products are available in various package styles and pin configurations. This chapter describes the signals and available pin configurations for each package style. For more information on the physical package specifications, see [Packaging](#) on page 297.

Pin Configurations

[Figure 2](#) displays the pin configuration for the packages available in the Z8FMC16100 Series Flash MCU. See [Table 1](#) for description of each signal.

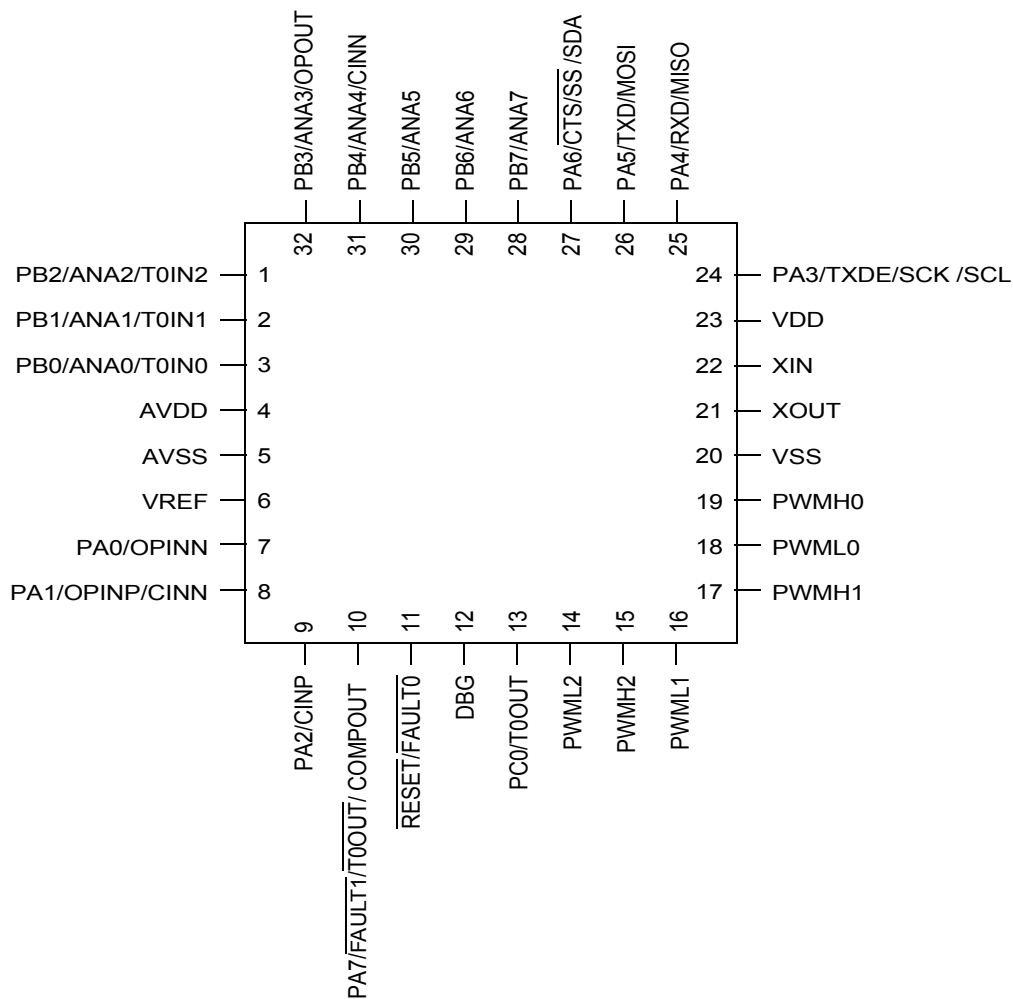

Figure 2. Z8FMC16100 Series Flash MCU in 32-Pin QFN and LQFP Package

Signal Descriptions

Table 1 describes the Z8FMC16100 Series Flash MCU signals.

Table 1. Signal Descriptions

Signal Mnemonic	I/O	Description
General-Purpose Input/Output Ports A–H		
PA[7:0]	I/O	Port A[7:0]: These pins are used for general-purpose I/O.
PB[7:0]	I/O	Port B[7:0]: These pins are used for general-purpose I/O.
PC[0]	I/O	Port C[0]: These pins are used for general-purpose I/O.
Pulse Width Modulator for Motor Control		
PWMH0/PWMH1/ PWMH2	O	PWM High output.
PWML0/PWML1/ PWML2	O	PWM Low output.
FAULT0/FAULT1	I	PWM FAULT condition input. FAULT0 is active Low, FAULT1 is active Low.
Serial Peripheral Interface		
MISO	I/O	Master-In/Slave-Out.
MOSI	I/O	Master-Out/Slave-In.
SCLK	I/O	SPI Clock.
SS	I	Slave Select
Timers		
T0OUT, T0OUT	O	General-Purpose Timer Outputs.
T0INx	I	General-Purpose Timer Input: This signal is used as the capture, gating and counter inputs.
UART Controller		
TXD	O	Transmit Data: This signal is the transmit output from the UART and IrDA.
RXD	I	Receive Data: This signal is the receiver input for the UART and IrDA.
CTS	I	Clear To Send signal from the receiving device that ready to receive data.
TXDE	O	Driver Enable: This signal allows automatic control of external RS-485 drivers. The DE signal may be used to ensure an external RS-485 driver is enabled when data is transmitted by the UART.

Table 1. Signal Descriptions (Continued)



Signal Mnemonic	I/O	Description
Analog		
ANA[7:0]	I	Analog Input: These signals are inputs to the ADC.
V _{REF}	I/O	Voltage buffer output: This signal provides reference voltage for external components.
 Caution		<i>If using the internal reference voltage generator, a 10 μF capacitor must be placed on this pin to Ground.</i>
CINP	I	Comparator positive input.
CINN	I	Comparator negative input.
COMPOUT	O	Comparator output.
OPINP	I	Operational amplifier positive input.
OPINN	I	Operational amplifier negative input.
OPOUT	O	Operational amplifier output.
Oscillators		
X _{IN}	I	The External Crystal Input is the input pin to the crystal oscillator. A crystal can be connected between it and the X _{OUT} pin to form the oscillator. In addition, this pin is used with external RC networks or external clock drivers to provide the system clock.
X _{OUT}	O	External Crystal Output: This pin is the output of the crystal oscillator. A crystal is connected between it and the X _{IN} pin to form the oscillator. This pin must be left unconnected when not using a crystal.
On-Chip Debugger		
DBG	I/O	Debug: This open-drain pin provides the single-pin control and data interface to the OCD. For operation of the OCD, all power pins (V _{DD}) must be supplied with power, and all ground pins (V _{SS}) must be grounded.
 Caution		<i>This pin is open-drain and must have an external pull-up resistor to ensure proper operation.</i>
Reset–PWM Fault		
RESET/FAULT0	I/O	The default state of the RESET pin is determined by FLTSEL bit7 in user Flash Option2 byte in location 0001 as either 1=RESET or 0=FAULT0. Subsequent change to FLTSEL bit0 in RSTSTAT register by software can set the pin to either 0=RESET or 1=FAULT0.

Table 1. Signal Descriptions (Continued)

Signal Mnemonic	I/O	Description
Power Supply		
V_{DD} , AV_{DD}	I	Power Supply.
V_{SS} , AV_{SS}	I	Ground.

Pin Characteristics

Table 2 lists the characteristics for each Z8FMC16100 Series Flash MCU's 32 pins. Data in Table 2 is sorted alphabetically by the pin symbol mnemonic.

Table 2. Pin Characteristics of the Z8FMC16100 Series Flash MCU

Symbol Mnemonic	Direction	Reset Direction	Active Low or Active High	Tri-State Output	Internal Pull-up or Pull-down	Schmitt Trigger Input	Open Drain Output
DBG	I/O	I	N/A	Yes	Pull-up	Yes	Yes
PA[7:0]	I/O	I	N/A	Yes	Pull-up, Programmable	Yes	Yes, Programmable
PB[7:0]	I/O	I	N/A	Yes	Pull-up, Programmable	Yes	Yes, Programmable
PC[0]	I/O	I	N/A	Yes	Pull-up, Programmable	Yes	Yes, Programmable
PWMxH	I/O	Tristate	N/A	Yes	No	Yes	No
PWMxL	I/O	Tristate	N/A	Yes	No	Yes	No
$\overline{\text{RESET}}$	I	I	Low	N/A	Pull-up	Yes	N/A
X_{IN}	I	I	N/A	N/A	No	No	N/A
V_{REF}	I/O	I	N/A	Yes	N/A	N/A	N/A
V_{DD} , AV_{DD}	Supply	N/A	N/A	N/A	No	No	N/A
V_{SS} , AV_{SS}	Supply	N/A	N/A	N/A	No	No	N/A

Note: x represents integers 0, 1,... to indicate multiple pins with symbol mnemonics which differ only by an integer.

Address Space

The eZ8 CPU can access three distinct address spaces:

- The Register File contains addresses for the general-purpose registers, eZ8 CPU, peripheral, and GPIO port control registers.
- The Program Memory contains addresses for all the memory locations having executable code and/or data.
- The Data Memory contains addresses for all the memory locations that hold data only.

For more information on the eZ8 CPU and its address space, refer to *eZ8 CPU User Manual (UM0128)*, available for download at www.zilog.com.

Register File

The Z8FMC16100 Series Flash MCU supports up to 512 B of internal RAM within the Register File address space. The Register File is composed of two sections—**Control Registers** and **General-Purpose Registers (RAM)**. When instructions are executed, registers are read from when defined as sources and written to when defined as destinations. The eZ8 CPU architecture allows all general-purpose registers to function as accumulators, address pointers, index registers, stack areas, or scratch pad memory.

The upper 256 bytes of the 4 KB Register File address space are reserved for control of the eZ8 CPU, on-chip peripherals, and I/O ports. These registers are located at addresses ranging from F00h to FFFh. Some of the addresses within the 256 byte control register section are reserved (unavailable). Reading from reserved Register File addresses returns an undefined value.



Caution: *Writing to reserved Register File addresses is not recommended and can produce unpredictable results.*

The on-chip RAM always begins at address 000h in the Register File address space. The Z8FMC16100 Series Flash MCU devices provide 512 B of on-chip RAM depending upon the device. Reading from Register File addresses outside the available RAM addresses (and not within the control register address space) returns an undefined value. Writing to these Register File addresses produces no effect. To determine the amount of RAM available for the specific Z8FMC16100 Series Flash MCU device, see [Ordering Information for the Z8FMC16100 Series Products*](#) on page 299.

Program Memory

The Z8FMC16100 Series Flash MCU products contain 16 KB of on-chip Flash Memory in the Program Memory address space, depending upon the device (FMC08100 has 8 KB and FMC04100 has 4 KB). Reading from Program Memory addresses outside the available Flash Memory addresses returns `FFh`. Writing to these unimplemented Program Memory addresses produces no effect. [Table 3](#) lists the Program Memory Maps for the Z8FMC16100 Series Flash MCU products.

Table 3. Z8FMC16100 Series Flash MCU Program Memory Maps

Program Memory Address (Hex)	Function
Z8FMC16000 Products	
0000-0001	Option Bits
0002-0003	Reset Vector
0004-0007	System Exception Vectors
0008-003F	Interrupt Vectors
0040-3FFF	Program Memory

Note: See [Table 29](#) on page 50 for a list of interrupt vectors.

Data Memory

The Z8FMC16100 Series Flash MCU do not use the eZ8 CPUs 64 KB Data Memory address space.

Information Area

[Table 4](#) describes the Z8FMC16100 Series Flash MCU Information Area. This 512 byte Information Area is accessed by setting bit 7 of the Flash Page Select Register to 1. When access is enabled, the Information Area is mapped into the Program Memory and overlays the 512 bytes at addresses `FE00h` to `FFFFh`. When the Information Area access is enabled, execution of LDC and LDCI instructions from these Program Memory addresses return the Information Area data rather than the Program Memory data. Reads of these addresses through the OCD also returns the Information Area data. Code execution from these addresses continues to correctly use the Program Memory. Access to the Information Area is read-only.

Table 4. Z8FMC16100 Series Information Area Map

Program Memory Address (Hex)	Function
FE00h–FE3Fh	Reserved.
FE40h–FE5Fh	Part Number 20-character ASCII alphanumeric code Left justified and filled with zeros (ASCII Null character).
FE60h–FFFFh	Reserved.



Register File Address Map

Table 5 provides the address map for the Register File of the Z8FMC16100 Series Flash MCU.

Table 5. Register File Address Map

Address (Hex)	Register Description	Mnemonic	Reset (Hex)	Page No
General Purpose RAM—Z8FMC16 devices with 512 B On-Chip RAM				
000–1FF	General-Purpose Register File RAM	—	XX	11
200–EFF	Reserved	—	XX	
Timer 0				
F00	Timer 0 High Byte Register (T0H)	T0H	00	101
F01	Timer 0 Low Byte Register (T0L)	T0L	01	101
F02	Timer 0 Reload High Byte Register (T0RH)	T0RH	FF	102
F03	Timer 0 Reload Low Byte Register (T0RL)	T0RL	FF	102
F04	Timer 0 PWM High Byte Register (T0PWMH)	T0PWMH	00	103
F05	Timer 0 PWM Low Byte Register (T0PWML)	T0PWML	00	103
F06	Timer 0 Control 0 Register (T0CTL0)	T0CTL0	00	104
F07	Timer 0 Control 1 Register (T0CTL1)	T0CTL1	00	105
F08	ADC Timer 0 Capture Register, High Byte	ADCTCAP_H	XX	206
F09	ADC Timer 0 Capture Register, Low Byte	ADCTCAP_L	XX	207
F0A–F1F	Reserved	—	XX	
Pulse-Width Modulator				
F20	PWM Control 0 Register	PWMCTL0	00	76
F21	PWM Control 1 Register	PWMCTL1	00	78
F22	PWM Deadband Register	PWMDB	00	79
F23	PWM Minimum Pulse Width Filter	PWMMPF	00	79
F24	PWM Fault Mask Register	PWMFM	00	80
F25	PWM Fault Status Register	PWMFSTAT	X0X0-0XXXb	81
F26	PWM Input Sample Register	PWMIN	00	84

Table 5. Register File Address Map (Continued)

Address (Hex)	Register Description	Mnemonic	Reset (Hex)	Page No
F27	PWM Output Control Register	PWMOUT	00	85
F28	PWM Fault Control Register	PWMFCTL	00	83
F29	Current Sense ADC Trigger Control Register	PWMSHC	00	85
F2A–B	Reserved	—	XX	
F2C	PWM High Byte Register (PWMH)	PWMH	00	73
F2D	PWM Low Byte Register (PWML)	PWML	00	74
F2E	PWM Reload High Byte Register (PWMRH)	PWMRH	0F	74
F2F	PWM Reload Low Byte Register (PWML)	PWML	FF	75
F30	PWM 0 High Side Duty Cycle High Byte	PWMH0Dh	00	75
F31	PWM 0 High Side Duty Cycle Low Byte	PWMH0DL	00	76
F32	PWM 0 Low Side Duty Cycle High Byte	PWML0Dh	00	75
F33	PWM 0 Low Side Duty Cycle Low Byte	PWML0DL	00	76
F34	PWM 1 High Side Duty Cycle High Byte	PWMH1DH	00	75
F35	PWM 1 High Side Duty Cycle Low Byte	PWMH1DL	00	76
F36	PWM 1 Low Side Duty Cycle High Byte	PWML1DH	00	75
F37	PWM 1 Low Side Duty Cycle Low Byte	PWML1DL	00	76
F38	PWM 2 High Side Duty Cycle High Byte	PWMH2DH	00	75
F39	PWM 2 High Side Duty Cycle Low Byte	PWMH2DL	00	76
F3A	PWM 2 Low Side Duty Cycle High Byte	PWML2DH	00	75
F3B	PWM 2 Low Side Duty Cycle Low Byte	PWML2DL	00	76
F3C–F3F	Reserved	—	XX	

Table 5. Register File Address Map (Continued)

Address (Hex)	Register Description	Mnemonic	Reset (Hex)	Page No
LIN-UART				
F40	LIN-UART Transmit Data Register	U0TXD	XX	128
	LIN-UART Receive Data Register	U0RXD	XX	128
F41	LIN-UART Status 0 Register	U0STAT0	0000_011 Xb	129
F42	LIN-UART Control 0 Register	U0CTL0	00	133
F43	LIN-UART Control 1	U0CTL1	00	134
F44	LIN-UART Mode Select and Status	U0MDSTAT	00	131
F45	LIN-UART Address Compare	U0ADDR	00	138
F46	LIN-UART Baud Rate High Byte	U0BRH	FF	139
F47	LIN-UART Baud Rate Low Byte	U0BRL	FF	139
F48–F5F	Reserved	—	XX	
Inter-integrated circuit				
F50	I ² C Data Register	I2CDATA	00	182
F51	I ² C Interrupt Status Register	I2CISTAT	80	182
F52	I ² C Control Register	I2CCTL	00	184
F53	I ² C Baud Rate High Byte Register (I2CBRH)	I2CBRH	FF	186
F54	I ² C Baud Rate Low Byte Register (I2CBRL)	I2CBRL	FF	186
F55	I ² C State Register (I2CSTATE) - Description when DIAG = 0	I2CSTATE	0X	187
	I ² C State Register (I2CSTATE) - Description when DIAG = 1	I2CSTATE	00	188
F56	I ² C Mode Register	I2CMODE	00	190
F57	I ² C Slave Address Register	I2CSLVAD	00	191
F58–F5F	Reserved	—	XX	
Serial Peripheral Interface				
F60	SPI Data Register	SPIDATA	XX	155
F61	SPI Control Register	SPICTL	00	155
F62	SPI Status Register	SPISTAT	01	157

Table 5. Register File Address Map (Continued)

Address (Hex)	Register Description	Mnemonic	Reset (Hex)	Page No
F63	SPI Mode Register	SPIMODE	00	158
F64	SPI Diagnostic State Register	SPIDST	00	159
F65	Reserved	—	XX	
F66	SPI Baud Rate High Byte Register (SPIBRH)	SPIBRH	FF	160
F67	SPI Baud Rate Low Byte Register (SPIBRL)	SPIBRL	FF	160
F68–F6F	Reserved	—	XX	
Analog-to-Digital Converter				
F70	ADC Control Register 0	ADCCTL0	20	201
F71	ADC Raw Data High Byte Register	ADCRD_H	XX	202
F72	ADC Data High Byte Register	ADCD_H	XX	202
F73	ADC Data Low Bits Register	ADCD_L	XX	203
F74	Sample Settling Time Register	ADCSST	1F	204
F75	Sample Time Register	ADCST	A0	204
F76	ADC Clock Prescale Register	ADCCP	00	205
F77–F85	Reserved	—	XX	
Oscillator Control				
F86	Oscillator Control Register	OSCCTL	A0	231
F87	Oscillator Divide Register	OSCDIV	00	232
Trim Control				
F88–F8F	Reserved	—	XX	
Comparator and Op Amp				
F90	Comparator and Op Amp Control Register	CMPOPC	00	194
F91–FBF	Reserved	—	XX	
Interrupt Controller				
FC0	Interrupt Request 0 Register	IRQ0	00	53
FC1	IRQ0 Enable High Bit Register (IRQ0ENH)	IRQ0ENH	00	56
FC2	IRQ0 Enable Low Bit Register (IRQ0ENL)	IRQ0ENL	00	57
FC3	Interrupt Request 1 Register	IRQ1	00	54

Table 5. Register File Address Map (Continued)

Address (Hex)	Register Description	Mnemonic	Reset (Hex)	Page No
FC4	IRQ1 Enable High Bit Register (IRQ1ENH)	IRQ1ENH	00	57
FC5	IRQ1 Enable Low Bit Register (IRQ1ENL)	IRQ1ENL	00	58
FC9–FCE	Reserved	—	XX	
FCF	Interrupt Control Register	IRQCTL	00	58
GPIO Port A				
FD0	Port A Address	PAADDR	00	39
FD1	Port A Control	PACTL	00	40
FD2	Port A Input Data	PAIN	XX	46
FD3	Port A Output Data	PAOUT	00	47
GPIO Port B				
FD4	Port B Address	PBADDR	00	39
FD5	Port B Control	PBCTL	00	40
FD6	Port B Input Data	PBIN	XX	46
FD7	Port B Output Data	PBOUT	00	47
GPIO Port C				
FD8	Port C Address	PCADDR	00	39
FD9	Port C Control	PCCTL	00	40
FDA	Port C Input Data	PCIN	XX	46
FDB	Port C Output Data	PCOUT	00	47
Reset and Watchdog Timer				
FF0	Reset Status and Control Register	RSTSTAT	see Table 10	27
FF1	Reserved	—	XX	
FF2	Watchdog Timer Reload High Byte Register (WDTH)	WDTH	04	64
FF3	Watchdog Timer Reload Low Byte Register (WDTL)	WDTL	00	64
FF4–FF5	Reserved	—	XX	

Table 5. Register File Address Map (Continued)

Address (Hex)	Register Description	Mnemonic	Reset (Hex)	Page No
Trim				
FF6	Trim Bit Address Register	TRMADR	00	224
FF7	Trim Bit Data Register	TRMDR	00	225
Flash Memory Controller				
FF8	Flash Control Register Definitions	FCTL	00	215
FF8	Flash Status Register	FSTAT	00	216
FF9	Flash Page Select Register	FPS	00	217
FF9 (if enabled)	Flash Sector Protect Register	FPROT	00	218
FFA	Flash Frequency High Byte Register (FFREQH)	FFREQH	00	219
FFB	Flash Frequency Low Byte Register (FFREQL)	FFREQL	00	219
eZ8 CPU				
FFC	Flags	FLAGS	XX	Refer to the eZ8 CPU User Manual (UM01 28).
FFD	Register Pointer	RP	XX	
FFE	Stack Pointer High Byte	SPH	XX	
FFF	Stack Pointer Low Byte	SPL	XX	
Note: XX = undefined.				

Reset and Stop Mode Recovery

The Reset Controller within the Z8FMC16100 Series Flash MCU controls RESET and Stop Mode Recovery operation. In typical operation, the following events cause a RESET to occur:

- Power-On Reset
- Voltage Brownout (VBO)
- Watchdog Timer timeout (when configured through the WDT_RES Option Bit to initiate a Reset)
- External $\overline{\text{RESET}}$ pin assertion
- OCD initiated RESET (OCDCTL[0] set to 1)
- Fault detect logic

When the Z8FMC16100 Series Flash MCU is in STOP mode, a Stop Mode Recovery is initiated by either of the following:

- WDT timeout
- GPIO port input pin transition on an enabled Stop Mode Recovery source

Reset Types

The Z8FMC16100 Series Flash MCU provides two different types of reset operation: **System Reset** and **Stop Mode Recovery**. The type of reset is a function of both the current operating mode of the Z8FMC16100 Series Flash MCU and the source of the reset. [Table 6](#) lists the types of reset and their operating characteristics.

Table 6. Reset and Stop Mode Recovery Characteristics and Latency

Reset Type	Reset Characteristics and Latency		
	Peripheral Control Registers	eZ8 CPU	Reset Latency (Delay)
System Reset	Reset (as applicable)	RESET	A minimum of 66 IPO cycles.
Stop Mode Recovery	Unaffected, except RSTSRC and OSCCTL registers	Reset	A minimum of 66 IPO cycles.

System Reset

During a system reset, the Z8FMC16100 Series Flash MCU is held in RESET for 66 cycles of internal precision oscillator (IPO). At the beginning of RESET, all GPIO pins are configured as inputs. All GPIO programmable pull-ups are disabled.

At the beginning of a System Reset, the motor control PWM outputs are forced to high-impedance momentarily. When the Option Bits which control the off-state have been properly evaluated the PWM outputs are forced to the programmed off-state.

During RESET, the eZ8 CPU and on-chip peripherals are idle; however, the IPO and WDT oscillator continue to run. During the first 50 clock cycles the internal option bit registers are initialized after which the system clock for the core and peripherals begins operating. The eZ8 CPU and on-chip peripherals remain idle through the next 16 cycles of the system clock after which time the internal reset signal is deasserted.

On RESET, control registers within the Register File which have a defined reset value are loaded with their reset values. Other control registers (including the Flags) and general-purpose RAM are undefined following RESET. The eZ8 CPU fetches the RESET vector at Program Memory addresses 0002h and 0003h and loads that value into the Program Counter. Program execution begins at the RESET vector address.

Table 7 lists the system reset sources as a function of the operating mode. The text following provides more detailed information on the individual RESET sources.

► **Note:** *A POR/VBO event always has priority over all other possible reset sources to ensure a full system reset occurs.*

Table 7. System Reset Sources and Resulting Reset Action

Operating Mode	System Reset Source	Action
NORMAL or HALT modes	POR/VBO.	System Reset.
	WDT timeout when configured for reset.	System Reset.
	$\overline{\text{RESET}}$ pin assertion.	System Reset.
	Write OCDCTL[0] to 1.	System Reset except the OCD is not reset.
	Fault detect logic reset.	System Reset.
STOP mode	Power-on reset/Voltage Brownout.	System Reset.
	$\overline{\text{RESET}}$ pin assertion.	System Reset.
	Fault detect logic reset.	System Reset.

Power-On Reset

Each device in the Z8FMC16100 Series Flash MCU contains an internal Power-On Reset (POR) circuit. The POR circuit monitors the supply voltage and holds the device in the Reset state until the supply voltage reaches a safe operating level. After the supply voltage exceeds the POR voltage threshold (V_{POR}) and has stabilized, the POR Counter is enabled and counts 50 cycles of the IPO. At this point, the System Clock is enabled and the POR Counter counts a total of 16 system clock pulses. The device is held in the Reset state until this second POR Counter sequence has timed out. Once the Z8FMC16100 Series Flash MCU exits the Power-On Reset state, the eZ8 CPU fetches the Reset vector. Following POR, the POR status bit in the [Reset Status and Control Register](#) is set to 1.

Figure 3 displays the POR operation. For POR threshold voltage (V_{POR}), see [On-Chip Peripheral AC and DC Electrical Characteristics](#) on page 262.

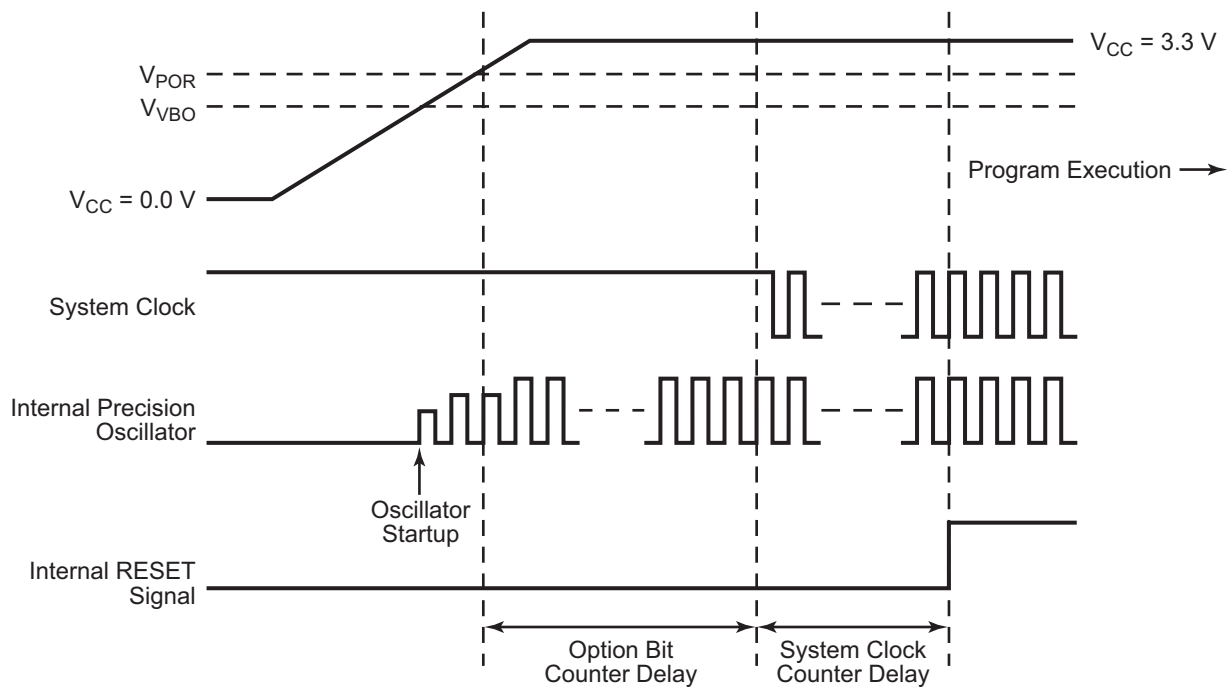

Figure 3. Power-On Reset Operation

Voltage Brownout Reset

The Z8FMC16100 Series Flash MCU provides low VBO protection. The VBO circuit senses when the supply voltage drops to an unsafe level (below the VBO threshold voltage) and forces the device into the Reset state. While the supply voltage remains below the POR voltage threshold (V_{POR}), the VBO holds the device in the Reset state.

After the supply voltage again exceeds the POR voltage threshold and stabilized, the device progresses through a full System Reset sequence, as described in the Power-on reset section. Following POR, the POR status bit in the Reset Source register is set to 1. Figure 4 displays the VBO operation. For VBO and POR threshold voltages (V_{VBO} and V_{POR}), see [On-Chip Peripheral AC and DC Electrical Characteristics](#) on page 262.

The VBO circuit can be either enabled or disabled during STOP mode. Operation during STOP mode is controlled by the VBO_AO Option Bit. For information on configuring VBO_AO , see [Option Bits](#) on page 221.

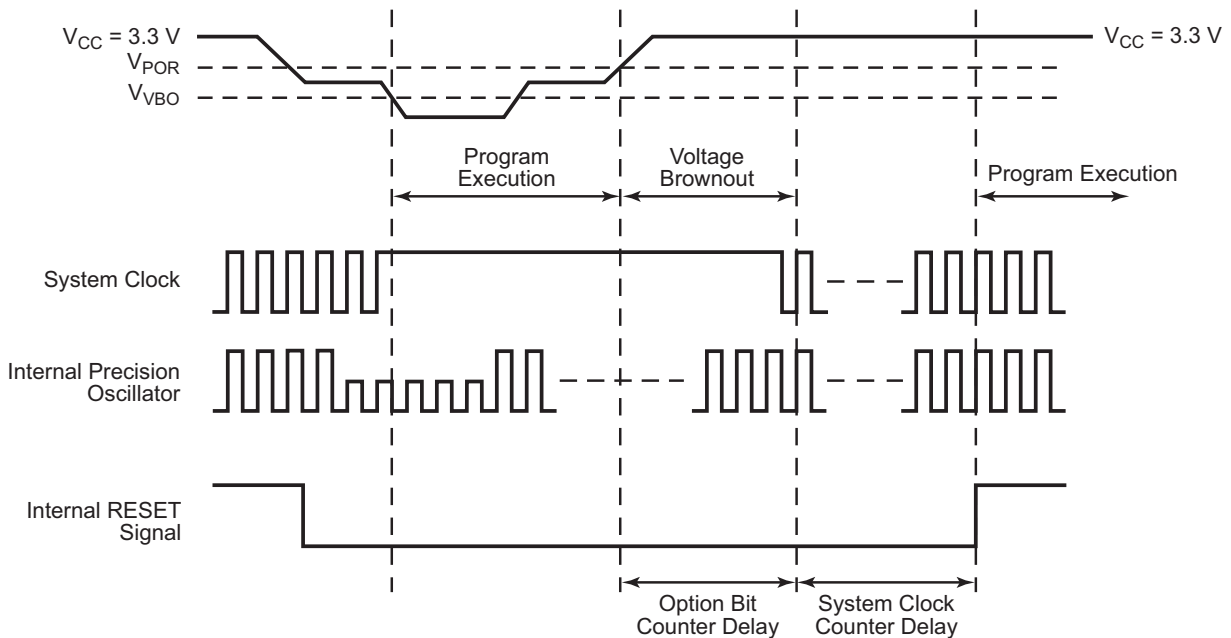

Figure 4. Voltage Brownout Reset Operation

Watchdog Timer Reset

If the device is in normal or HALT mode, the WDT can initiate a System Reset at timeout if the WDT_RES Option Bit is set to 1. This setting is the default (unprogrammed) setting of the WDT_RES Option Bit. The WDT status bit in the [Reset Status and Control Register](#) is set to signify that the reset was initiated by the WDT.

External Pin Reset

The input-only \overline{RESET} pin has a Schmitt-triggered input, an internal pull-up, an analog filter, and a digital filter to reject noise. When the \overline{RESET} pin is asserted for at least 4 system clock cycles, the device progresses through the System Reset sequence. While the \overline{RESET} input pin is asserted Low, the Z8FMC16100 Series Flash MCU device

continues to be held in the Reset state. If the $\overline{\text{RESET}}$ pin is held Low beyond the System Reset timeout, the device exits the Reset state 16 system clock cycles following $\overline{\text{RESET}}$ pin deassertion. If the $\overline{\text{RESET}}$ pin is released before the System Reset timeout, the $\overline{\text{RESET}}$ pin is driven Low by the chip until the completion of the timeout as described in the next section. In STOP mode the digital filter is bypassed because the System Clock is disabled.

Following a System Reset initiated by the external $\overline{\text{RESET}}$ pin, the EXT status bit in the [Reset Status and Control Register](#) is set to 1.

External Reset Indicator

During System Reset, the $\overline{\text{RESET}}$ pin functions as an open-drain (active Low) reset mode indicator in addition to the input functionality. This reset output feature allows a Z8FMC16100 Series Flash MCU device to reset other connected components, even if the reset is caused by internal sources such as POR, VBO, or WDT events and as an indication of when the reset sequence completes.

After an internal reset event occurs, the internal circuitry begins driving the $\overline{\text{RESET}}$ pin Low. The $\overline{\text{RESET}}$ pin is held Low by the internal circuitry until the appropriate delay listed in [Table 6](#) has elapsed.

On-Chip Debugger Initiated Reset

A System Reset may be initiated through the OCD by setting RST bit of the OCDCTL register. The OCD is not reset but the rest of the chip goes through a normal System Reset. The RST bit automatically clears during the system reset. Following the system reset, the POR bit in the [Reset Status and Control Register](#) is set.

Fault Detect Logic Reset

Fault detect circuitry exists to detect *illegal* state changes which may be caused by transient power or electrostatic discharge events. When such a fault is detected, a system reset is forced. Following the system reset, the FLTD bit in the [Reset Status and Control Register](#) is set.

Stop Mode Recovery

The STOP mode is entered by execution of a STOP instruction by the eZ8 CPU. For detailed STOP mode information, see [Low-Power Modes](#) on page 29. During Stop Mode Recovery, the device is held in reset for 66 cycles of the IPO. Stop Mode Recovery only affects the contents of the [Reset Status and Control Register](#) and [Oscillator Control Register](#). Stop Mode Recovery does not affect any other values in the Register File, including the Stack Pointer, Register Pointer, Flags, peripheral control registers, and general-purpose RAM.

The eZ8 CPU fetches the Reset vector at Program Memory addresses 0002h and 0003h and loads that value into the Program Counter. Program execution begins at the Reset vector address. Following Stop Mode Recovery, the STOP bit in the [Reset Status and Control Register](#) is set to 1. [Table 8](#) lists the Stop Mode Recovery sources and resulting actions.

Table 8. Stop Mode Recovery Sources and Resulting Action

Operating Mode	Stop Mode Recovery Source	Action
Stop Mode	WDT timeout when configured for Reset	Stop Mode Recovery
	WDT timeout when configured for System Exception	Stop Mode Recovery followed by WDT System Exception
	Data transition on any GPIO port pin enabled as a Stop Mode Recovery source	Stop Mode Recovery

Stop Mode Recovery Using Watchdog Timer Timeout

If the WDT times out during STOP mode, the device undergoes a SMR sequence. In the [Reset Status and Control Register](#), the WDT and STOP bits are set to 1. If the WDT is configured to generate a System Exception upon timeout, the eZ8 CPU services the WDT System Exception following the normal Stop Mode Recovery sequence.

Stop Mode Recovery Using a GPIO Port Pin Transition

Each of the GPIO port pins may be configured as a Stop Mode Recovery input source. On any GPIO pin enabled as a Stop Mode Recovery source, a change in the input pin value (from High to Low or from Low to High) initiates Stop Mode Recovery. The GPIO Stop Mode Recovery signals are filtered to reject pulses less than 10 ns (typical) in duration. In the [Reset Status and Control Register](#), the STOP bit is set to 1.



Caution: *Short pulses on the Port pin can initiate Stop Mode Recovery without initiating an interrupt (if enabled for that pin).*

PWM Fault0 and Reset pin selection

The $\overline{\text{RESET}}$ pin can be set to function as a PWM Fault input. When selected, the $\overline{\text{RESET}}$ input function is disabled. The FLTSEL bit in the [Reset Status and Control Register](#) allows software selection of the $\overline{\text{RESET}}$ pin function. The pin function is selected by writing the the unlock sequence followed by the mode to this register. A software write to the FLTSEL bit overrides the value set by the FLTSEL user option bit

Reset Control Register Definitions

Writing the 14h, 92h unlock sequence to the Reset Status and Control register address unlocks access to the FLTSEL bit. The locking mechanism prevents spurious writes to this bit. The following sequence is required to unlock this register and write the FLTSEL bit:

1. Write 14h to the Reset Status and Control register (RSTSTAT).
2. Write 92h to the Reset Status and Control register (RSTSTAT).
3. Write the FLTSEL bit.

All steps of the unlock sequence must be written in the order listed.

Reset Status and Control Register

The Reset Status and Control register (Table 9) records the cause of the most recent Reset or Stop Mode Recovery. All status bits are updated on each Reset or Stop Mode Recovery event. Table 10 indicates the possible states of the Reset status bits following a Reset or Stop Mode Recovery event. The $\overline{\text{RESET}}$ pin function is also select with FLTSEL bit.

Table 9. Reset Status and Control Register (RSTSTAT)

BITS	7	6	5	4	3	2	1	0
FIELD	POR	STOP	WDT	EXT	FLT	Reserved		FLTSEL
RESET	See Table 10							u
R/W	R	R	R	R	R	R		R/W
ADDR	FF0H							

The FLTSEL bit in this register allows software selection of the $\overline{\text{RESET}}$ pin. The pin function is selected by writing the unlock sequence followed by the mode to this register. A software write to the FLTSEL bit 0 in the RSTSTAT register overrides the value set by the FLTSEL bit 7 in the User Flash Option2 byte location.

0 = $\overline{\text{RESET}}/\overline{\text{Fault0}}$ pin is configured as $\overline{\text{RESET}}$ input.

1 = $\overline{\text{RESET}}/\overline{\text{Fault0}}$ pin is configured as $\overline{\text{Fault0}}$ input.

- **Note:** *If the FLTSEL bit 7 in the Flash Option2 location is programmed to 0 then after reset, the FLTSEL bit 0 in the RSTSTAT is set to 1. If the FLTSEL bit 7 in the Flash Option2 location is unprogrammed (1) then after reset, the FLTSEL bit 0 in the RSTSTAT is set to 0.*

Table 10. Reset Status Register Values following Reset

Reset or Stop Mode Recovery Event	POR	STOP	WDT	EXT	FLT
Power-On Reset	1	0	0	0	0
Reset using $\overline{\text{RESET}}$ pin assertion	0	0	0	1	0
Reset using Watchdog Timer timeout	0	0	1	1	0
Reset by OCD writing OCDCTL[0] to 1	1	0	0	1	0
Reset from Fault Detect Logic	0	0	0	1	1
Stop Mode Recovery using GPIO pin transition	0	1	0	0	0
Stop Mode Recovery using WDT timeout	0	1	1	0	0

Note: Additional bits may be set depending on the number of resets simultaneously occurring.

Low-Power Modes

The Z8FMC16100 Series Flash MCU products contain power saving features. The highest level of power reduction is provided by STOP mode. The next level of power reduction is provided by the HALT mode.

STOP Mode

Executing eZ8 CPU's STOP instruction places the Z8FMC16100 Series Flash MCU into STOP mode. In STOP mode, the operating characteristics include:

- Primary crystal oscillator and IPO are stopped; XIN and XOUT pins are driven to V_{SS} .
- System clock is stopped.
- eZ8 CPU is stopped.
- Program counter (PC) stops incrementing.
- If enabled for operation during STOP mode, the WDT and its internal RC oscillator continue to operate.
- If enabled for operation in STOP mode through the associated Option Bit, the VBO circuit continues to operate.
- Comparators and voltage reference operate unless disabled.
- All other on-chip peripherals are idle.

To minimize current in STOP mode, all GPIO pins which are configured as digital inputs must be driven to one of the supply rails (V_{CC} or GND), the VBO and WDT must be disabled. The device can be brought out of STOP mode using Stop Mode Recovery. For more information, see [Reset and Stop Mode Recovery](#) on page 21.



Caution: *To prevent excess current consumption, STOP mode must not be used if the device is driven with an external clock source.*

HALT Mode

Execution of the eZ8 CPU's HALT instruction places the device into HALT mode. In HALT mode, the operating characteristics are:

- Primary crystal oscillator is enabled and continues to operate
- System clock is enabled and continues to operate
- eZ8 CPU is stopped

- Program counter (PC) stops incrementing
- WDT's internal RC oscillator continues to operate
- If enabled, the WDT continues to operate
- All other on-chip peripherals continue to operate

The eZ8 CPU can be brought out of HALT mode by any of the following operations:

- Interrupt or System Exception.
- WDT timeout (System Exception or Reset).
- Power-On Reset.
- Voltage Brownout Reset.
- External $\overline{\text{RESET}}$ pin assertion.
- Halt Mode Recovery time is less than 5 μs .

To minimize current in HALT mode, all GPIO pins which are configured as inputs must be driven to one of the supply rails (V_{CC} or GND).

Peripheral-Level Power Control

In addition to the STOP and HALT modes, it is possible to disable unused on-chip analog peripherals of the Z8FMC16100 Series Flash MCU device during operation. Disabling an unused analog peripheral minimizes power consumption. Power consumption of the unused on-chip digital peripherals is automatically minimized when not in use.

Power Control Register 0

Each bit of the following registers disable a peripheral block, either by gating its system clock input or by removing power from the block.

Table 11. Power Control Register 0 (PWRCTL0)

BITS	7	6	5	4	3	2	1	0
FIELD	Reserved	Reserved	Reserved	VBODIS	Reserved	Reserved	Reserved	Reserved
RESET	0	0	0	0	0	0	0	0
R/W	R/W	R/W	R/W	R/W	R/W	R/W	R/W	R/W
ADDR	F80H							

Bit Position	Value (H)	Description
[7:5] Reserved		Must be 0.
[4] VBODIS		VBO Detector Disable (This bit and the <code>VBO_AO</code> Option Bit must be enabled for the VBO to be active).
	0	VBO Detector is enabled.
	1	VBO Detector is disabled.
[3:0] Reserved		Must be 0.



General-Purpose Input/Output

The Z8FMC16100 Series Flash MCU contains general-purpose input/output pins (GPIO) arranged as Ports A–C. Each port contains control and data registers. The GPIO control registers determine data direction, open-drain, output drive current, pull-up, and alternate pin functions. Each port pin is individually programmable.

GPIO Port Availability By Device

Table 12 lists the port pins available with each device and package type.

Table 12. Port Availability by Device and Package Type

Package	Port A	Port B	Port C
32-pin	[7:0]	[7:0]	[0]



Caution: *All Port B, Port A1, Port C0, PA0, and PA2 are not 5 V tolerant. Any voltage above 3.6 V will affect the analog functions.*

Architecture

Figure 5 displays a simplified block diagram of a GPIO port pin. The figure displays the ability to accommodate alternate functions and variable port current drive strength are not illustrated.

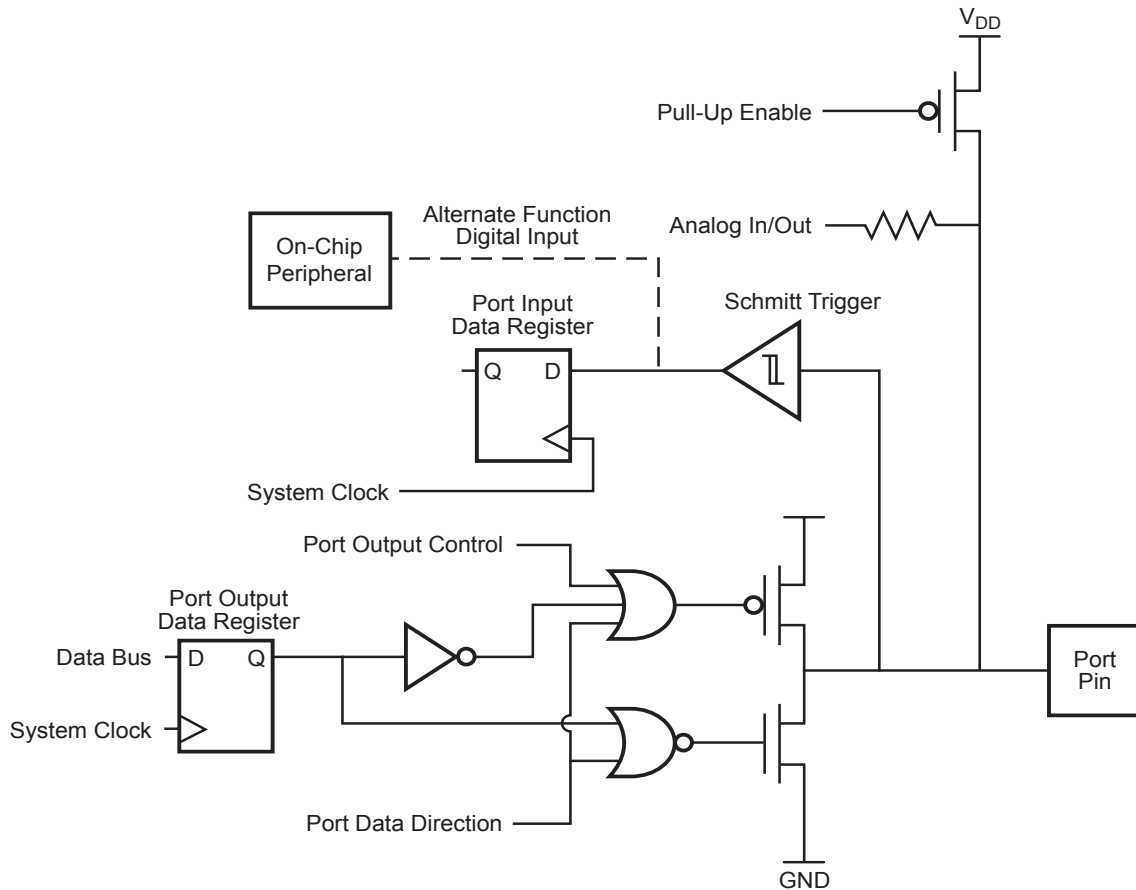

Figure 5. GPIO Port Pin Block Diagram

GPIO Alternate Functions

Many GPIO port pins can be used as both GPIO and to provide access to on-chip peripheral functions, like timers and serial communication devices. The Port A-C Alternate Function subregisters configure these pins for either GPIO or alternate function operation. When a pin is configured for alternate function, control of the port pin direction (input/output) is passed from Port A-C Data Direction registers to the alternate function assigned to this pin. For peripherals with digital input alternate functions (for example, a Timer input T0IN0), selecting the alternate function is not required.

Table 13 lists the alternate functions associated with each port pin and the required alternate function (AF0 and AF1) subregister settings. Enabling an analog alternate function automatically disables the digital Schmitt-trigger input for the associated port input.

Alternate function settings affect the pins direction (output enable) and muxes the output data that come from the peripheral instead of GPIO. The input path coming from the pad to a peripheral is not blocked based on the alternate function setting. The alternate function need not be set for alternate function signals that are used as inputs. The alternate function can be configured as GPIO inputs. When the fault source is not in use, you must disable the input fault source at the peripheral so the fault input does not affect the peripheral.

Table 13. Port Alternate Function Mapping

Port	Pin	Mnemonic	AF0	AF1	Alternate Function Description
Port A	PA7	PA7	0	0	GPIO.
		T0OUT	0	1	Timer 0 output (active Low).
		$\overline{\text{FAULT1}}$	1	0	Fault Input.
		COMPOUT	1	1	Comparator output.
PA6	PA6	PA6	0	0	GPIO.
		SS	0	1	SPI Slave Select.
		CTS	1	0	UART Clear to Send.
		SDA	1	1	I ² C Serial Data.
PA5	PA5	PA5	0	0	GPIO.
		MOSI	0	1	SPI Master Out Slave In.
		TXD	1	0	UART Transmit data.
			1	1	Reserved; do not use.
PA4	PA4	PA4	0	0	GPIO.
		MISO	0	1	SPI Master In Slave Out.
		RXD	1	0	UART Receive data.
			1	1	Reserved; do not use.
PA3	PA3	PA3	0	0	GPIO.
		SCK	0	1	SPI Serial Clock.
		TXDE	1	0	UART Driver Enable.
		SCL	1	1	I ² C serial clock.
PA2	PA2	PA2	0	0	GPIO.
			0	1	Reserved; do not use.
		CINP	1	0	Comparator Positive Input.
			1	1	Reserved; do not use.

Table 13. Port Alternate Function Mapping (Continued)

Port	Pin	Mnemonic	AF0	AF1	Alternate Function Description
Port A	PA1	PA1	0	0	GPIO.
			0	1	Reserved; do not use.
			1	0	Op amp positive input and comparator negative input.
			1	1	Reserved; do not use.
	PA0	PA0	0	0	GPIO.
			0	1	Reserved; do not use.
			1	0	Op amp negative input.
			1	1	Reserved; do not use.
Port B	PB7	PB7	0	0	GPIO.
			0	1	Reserved; do not use.
			1	0	ADC analog input 7.
			1	1	Reserved; do not use.
	PB6	PB6	0	0	GPIO.
			0	1	Reserved; do not use.
			1	0	ADC analog input 6.
			1	1	Reserved; do not use.
	PB5	PB5	0	0	GPIO.
			0	1	Reserved; do not use.
			1	0	ADC analog input 5.
			1	1	Reserved; do not use.
	PB4	PB4	0	0	GPIO.
			0	1	Reserved; do not use.
			1	0	ADC analog input 4 (also CINN, if CPSEL=1).
			1	1	Reserved; do not use.
	PB3	PB3	0	0	GPIO.
			0	1	GPIO with edge interrupt.
			1	0	ADC analog input 3 and op amp output.
			1	1	Reserved; do not use.

Table 13. Port Alternate Function Mapping (Continued)

Port	Pin	Mnemonic	AF0	AF1	Alternate Function Description
Port B	PB2	PB2	0	0	GPIO/Timer 0 input 2.
		PB2INT	0	1	GPIO/Timer 0 input 2—edge interrupt enabled.
		ANA2	1	0	ADC analog input 2.
		T0IN2	1	1	Timer 0 input 2; dedicated input.
	PB1	PB1	0	0	GPIO/Timer 0 input 1.
		PB1INT	0	1	GPIO/Timer 0 input 1—edge interrupt enabled.
		ANA1	1	0	ADC analog input 1.
			1	1	Reserved; do not use.
PB0	PB0	0	0	GPIO/Timer 0 input 0.	
	PB0INT	0	1	GPIO/Timer 0 input 0—edge interrupt enabled.	
	ANA0	1	0	ADC analog input 0.	
		1	1	Reserved; do not use.	
Port C	PC0	PC0	0	0	GPIO.
			0	1	Reserved; do not use.
	T0OUT		1	0	Timer 0 output.
			1	1	Reserved; do not use.

GPIO Interrupts

Many GPIO port pins can be used as interrupt sources. The Port A[7:0] pins can be configured to generate an interrupt request on either the rising edge or falling edge of the pin input signal. The Port B[3:0] pins can be configured to generate an interrupt request on both the rising and falling edges of the pin input signal. For Port A, the GPIO interrupt edge selection is controlled by the Interrupt Edge Select subregister. Enabling and disabling of the Port Interrupts is handled in the Interrupt Controller. Port B[3:0], with dual edge interrupt capability, is selected by AF1, AF0. For more information, see [Interrupt Controller](#) on page 49.

GPIO Control Register Definitions

Four registers for each Port provide access to GPIO control, input data, and output data. [Table 14](#) lists these Port registers. Use the Port A–C Address and Control registers together to provide access to subregisters for Port configuration and control.

Table 14. GPIO Port Registers and Subregisters

Port Register Mnemonic	Port Register Name
PxADDR	Port A–C Address Register—selects subregisters.
PxCTL	Port A–C Control Register—provides access to subregisters.
PxIN	Port A–C Input Data Register.
PxOUT	Port A–C Output Data Register.
Port Subregister Mnemonic	Port Register Name
PxDD	Data Direction
PxAF0	Alternate Function 0
PxAF1	Alternate Function 1—Ports A and B only.
PxOC	Output Control (open-drain).
PxHDE	High Drive Enable.
PxSMRE	Stop Mode Recovery Source Enable.
PxPUE	Pull-Up Enable.
PxIRQES	Interrupt Edge Select—Ports A and C only.
IRQPSEL	Interrupt Port Select—Port A only.

Port A-C Address Registers

The Port A–C Address registers select the GPIO port functionality accessible through the Port A–C Control registers. The Port A–C Address and Control registers combine to provide access to all GPIO port control. See [Table 15](#).

Table 15. Port A–C GPIO Address Registers (PxADDR)

BITS	7	6	5	4	3	2	1	0
FIELD	PADDR[7:0]							
RESET	00H							
R/W	R/W							
ADDR	FD0H, FD4H, FD8H							

[Table 16](#) lists the Port Control subregisters accessible through Port A–C Control registers.

Table 16. Port Control Subregisters by Port Address

Port Address	Port Control Subregisters
00h	No function; provides some protection against accidental port reconfiguration.
01h	Data direction.
02h	Alternate Function 0
03h	Output Control (open-drain).
04h	High Drive Enable.
05h	Stop Mode Recovery source enable.
06h	Pull-up enable.
07h	Alternate Function 1—Ports A and Port B only.
08h	Interrupt Edge Select—Port A and Port C only
09h	Port Interrupt Select Register—Port A only
0Ah–FFh	No Function

Port A–C Control Registers

The Port A–C Control registers (PxCTL) set the GPIO port operation. The value in the corresponding Port A–C Address register determines the control subregisters accessible using the Port A–C Control registers (Table 17). The Port Control registers provide access to all subregisters that configure GPIO port operation.

Table 17. Port A–C Control Registers (PxCTL)

BITS	7	6	5	4	3	2	1	0
FIELD	PCTL							
RESET	00H							
R/W	R/W							
ADDR	FD1H, FD5H, FD9H							

Port A–C Data Direction Subregisters

The Port A–C Data Direction subregisters are accessed through the Port A–C Control registers by writing 01h to the Port A–C Address registers. See Table 18.

In each of these three data direction subregisters, bits [7:0] control the direction of the associated port pin. Port Alternate Function operation overrides the Data Direction register setting.

If the value of bit is 0, the direction is output, and data in the Port A–C Output Data registers is driven onto the port pin.

If the value of bit is 1, the direction is input. The port pin is sampled, the value is written into the Port A–C Input Data registers, and the output driver is tristated.

Table 18. Port A–C Data Direction Subregisters

BITS	7	6	5	4	3	2	1	0
FIELD	DD7	DD6	DD5	DD4	DD3	DD2	DD1	DD0
RESET	1	1	1	1	1	1	1	1
R/W	R/W	R/W	R/W	R/W	R/W	R/W	R/W	R/W
ADDR	If 01H in Port A–C Address register, accessible through the Port A-C Control register							

Bit Position	Value (H)	Description
[7:0] Data Direction	0	These bits control the direction of the associated port pin. Port Alternate Function operation overrides the Data Direction register setting. Output. Data in the Port A–C Output Data register is driven onto the port pin.
	1	Input. The port pin is sampled and the value written into the Port A–C Input Data register. The output driver is tristated.

Port A–B Alternate Function 0 Subregisters

The Port A–B Alternate Function subregisters ([Table 19](#)) are accessed through Port A–B Control registers by writing 02h to the Port A–B Address registers. The Port A–B Alternate Function subregisters select the alternate functions for the selected pins. To determine the alternate function associated with each port pin, see [GPIO Alternate Functions](#) on page 34.



Caution: *You must not enable alternate function for GPIO port pins which do not have an associated alternate function. Failure to follow this guideline may result in unpredictable operation.*

Table 19. Port A–B Alternate Function 0 Subregisters

BITS	7	6	5	4	3	2	1	0
FIELD	AF0_7	AF0_6	AF0_5	AF0_4	AF0_3	AF0_2	AF0_1	AF0_0
RESET	0	0	0	0	0	0	0	0
R/W	R/W	R/W	R/W	R/W	R/W	R/W	R/W	R/W
ADDR	If 02H in Port A-C Address register, accessible through the Port A-C Control register							

Bit Position	Value (H)	Description
[7:0] AF0	0	Port Alternate Function 0 select. The alternate function 0 function is not selected.
	1	The alternate function 0 function is selected.

Port A–C Output Control Subregisters

The Port A–C Output Control subregisters (Table 20) are accessed through the Port A–C Control registers by writing 03h to the Port A–C Address registers. Setting the bits in the Port A–C Output Control subregisters to 1 configures the specified port pins for open-drain operation. These subregisters affect the pins directly, as a result, alternate functions are also affected.

Table 20. Port A–C Output Control Subregisters

BITS	7	6	5	4	3	2	1	0
FIELD	POC7	POC6	POC5	POC4	POC3	POC2	POC1	POC0
RESET	0	0	0	0	0	0	0	0
R/W	R/W	R/W	R/W	R/W	R/W	R/W	R/W	R/W
ADDR	If 03H in Port A–C Address register, accessible through the Port A–C Control register							

Bit Position	Value (H)	Description
[7:0] POC	0	Port Output Control These bits function independently of the alternate function bit and disable the drains if set to 1. The drains are enabled for any output mode.
	1	The drain of the associated pin is disabled (open-drain mode).

Port A–C High Drive Enable Subregisters

The Port A–C High Drive Enable subregisters (Table 21) are accessed through the Port A–C Control registers by writing 04h to the Port A–C Address registers. Setting the bits in the Port A–C High Drive Enable subregisters to 1 configures the specified port pins for high current output drive operation. The Port A–C High Drive Enable subregisters affect the pins directly. As a result, alternate functions are also affected.

Table 21. Port A–C High Drive Enable Subregisters

BITS	7	6	5	4	3	2	1	0
FIELD	PHDE7	PHDE6	PHDE5	PHDE4	PHDE3	PHDE2	PHDE1	PHDE0
RESET	0	0	0	0	0	0	0	0
R/W	R/W	R/W	R/W	R/W	R/W	R/W	R/W	R/W
ADDR	If 04H in Port A-C Address register, accessible through the Port A-C Control register							

Bit Position	Value (H)	Description
--------------	-----------	-------------

[7:0]		Port High Drive Enable
PHDE	0	The Port pin is configured for standard output current drive.
	1	The Port pin is configured for high output current drive.

Port A–C Stop Mode Recovery Source Enable Subregisters

The Port A–C Stop Mode Recovery Source Enable subregisters (Table 22) are accessed through the Port A–C Control registers by writing 05h to the Port A–C Address registers. Setting the bits in the Port A–C Stop Mode Recovery Source Enable subregisters to 1 configures the specified port pins as a Stop Mode Recovery source. During STOP mode, any logic transition on a port pin enabled as a Stop Mode Recovery source initiates Stop Mode Recovery.

Table 22. Port A–C STOP Mode Recovery Source Enable Subregisters

BITS	7	6	5	4	3	2	1	0
FIELD	PSMRE7	PSMRE6	PSMRE5	PSMRE4	PSMRE3	PSMRE2	PSMRE1	PSMRE0
RESET	0	0	0	0	0	0	0	0
R/W	R/W	R/W	R/W	R/W	R/W	R/W	R/W	R/W
ADDR	If 05H in Port A–C Address register, accessible through the Port A–C Control register							

Bit Position	Value (H)	Description
[7:0] PSMRE	0	Port STOP Mode Recovery Source Enable The Port pin is not configured as a STOP Mode Recovery source. Transitions on this pin during STOP mode do not initiate STOP Mode Recovery.
	1	The Port pin is configured as a STOP Mode Recovery source. Any logic transition on this pin during STOP mode initiates STOP Mode Recovery.

The Port A–C Pull-Up Enable subregisters (Table 23), are accessed through the Port A–C Control registers by writing 06h to the Port A–C Address registers. Setting the bits in the Port A–C Pull-Up Enable subregisters enables a weak internal resistive pull-up on the specified port pins.

Table 23. Port A–C Pull-Up Enable Subregisters

BITS	7	6	5	4	3	2	1	0
FIELD	PPUE7	PPUE6	PPUE5	PPUE4	PPUE3	PPUE2	PPUE1	PPUE0
RESET	0	0	0	0	0	0	0	0
R/W	R/W	R/W	R/W	R/W	R/W	R/W	R/W	R/W
ADDR	If 06H in Port A–C Address register, accessible through the Port A–C Control register							

Bit Position	Value (H)	Description
[7:0] PPUE	0	Port Pull-Up Enable The weak pull-up on the Port pin is disabled.
	1	The weak pull-up on the Port pin is enabled.

Port A Interrupt Edge Select Subregister

The Interrupt Edge Select (IRQES) Subregister (Table 24) determines whether an interrupt is generated for the rising edge or falling edge on the selected GPIO Port A input pin.

Table 24. Interrupt Edge Select Subregister (IRQES)

BITS	7	6	5	4	3	2	1	0
FIELD	Reserved				IES3	IES2	IES1	IES0
RESET	0	0	0	0	0	0	0	0
R/W	R	R	R	R	R/W	R/W	R/W	R/W
ADDR	If 08H in Port A Address register, accessible through the Port A and Port C Control register							

Bit Position	Value (H)	Description
[3:0] IESx	0	Interrupt Edge Select x An interrupt request is generated on the falling edge of the PAX input.
	1	An interrupt request is generated on the rising edge of the PAX input, where x indicates the specific GPIO Port pin number (0 through 7).

Interrupt Port Select Register

The Interrupt Port Select register subregister (Table 25) is used to select which Port A pins are used as interrupts.

Table 25. Interrupt Port Select Subregister (IRQPS)

BITS	7	6	5	4	3	2	1	0
FIELD	Reserved				PA73SEL	PA62SEL	PA51SEL	PA40SEL
RESET	0	0	0	0	0	0	0	0
R/W	R	R	R	R	R/W	R/W	R/W	R/W
ADDR	If 09H in Port A Address register, accessible through the Port A and Port C Control register							

Bit Position	Value (H)	Description
[3:0] PAxxSEL	0	Interrupt Port Select x An interrupt request is generated on PAX, where x indicates (0 through 3)
	1	An interrupt request is generated on PAX, where x indicates (4 through 7)

Port B Alternate Function 1 Subregisters

The Port B Alternate Function Subregisters (Table 26) is accessed through the Port B Control register by writing 08H to the Port B Address register. The Port B Alternate Function subregister selects the alternate functions for the selected pins. To determine the alternate function associated with each port pin, see [GPIO Alternate Functions](#) on page 34.



Caution: Do not enable alternate function for GPIO port pins which do not have an associated alternate function. Failure to follow this guideline may result in unpredictable operation.

Table 26. Port A–B Alternate Function 1 Subregisters

BITS	7	6	5	4	3	2	1	0
FIELD	AF1_7	AF1_6	AF1_5	AF1_4	AF1_3	AF1_2	AF1_1	AF1_0
RESET	0	0	0	0	0	0	0	0
R/W	R/W	R/W	R/W	R/W	R/W	R/W	R/W	R/W
ADDR	If 07H in Port A-C Address register, accessible through the Port A-C Control register							

Bit Position	Value (H)	Description
[7:0] AF1	0	Port Alternate Function 1 select. The alternate function 1 function is not selected.
	1	The alternate function 1 function is selected.

Port A-C Input Data Registers

Reading from the Port A–C Input Data registers (Table 27) return the sampled values from the corresponding port pins. The Port A–C Input Data registers are read-only. Sampled data are from the corresponding port pin input.

Table 27. Port A-C Input Data Registers (PxIN)

BITS	7	6	5	4	3	2	1	0
FIELD	PIN7	PIN6	PIN5	PIN4	PIN3	PIN2	PIN1	PIN0
RESET	X	X	X	X	X	X	X	X
R/W	R	R	R	R	R	R	R	R
ADDR	FD2H, FD6H, FDAH							

Bit Position	Value (H)	Description
[7:0] PIN	0	Port Input Data x Input data is a logical 0 (Low).
	1	Input data is a logical 1 (High).

Port A–C Output Data Registers

The Port A–C Output Data registers (Table 28) write output data to the pins. These bits contain the data to be driven out from the port pins. The values are only driven if the corresponding pin is configured as an output and the pin is not configured for alternate function operation.

Table 28. Port A-C Output Data Register (PxOUT)

BITS	7	6	5	4	3	2	1	0
FIELD	POUT7	POUT6	POUT5	POUT4	POUT3	POUT2	POUT1	POUT0
RESET	0	0	0	0	0	0	0	0
R/W	R/W	R/W	R/W	R/W	R/W	R/W	R/W	R/W
ADDR	FD3H, FD7H, FDBH							

Bit Position	Value (H)	Description
[7:0] POUT	0	Port Output Data x Drive is a logical 0 (Low).
	1	Drive is a logical 1 (High). High value is not driven if the drain has been disabled by setting the corresponding Port Output Control register bit to 1.

Interrupt Controller

The interrupt controller on the Z8FMC16100 Series Flash MCU prioritizes the system exceptions and interrupt requests from the on-chip peripherals and the GPIO port pins. The features of the interrupt controller include:

- Multiple GPIO interrupts.
- Interrupts for on-chip peripherals.
- Non-maskable system exceptions.
- Three levels of individually programmable interrupt priority.
- 20 sources of interrupts for the interrupt controller, 9 of the sources can be configured from GPIO pins.

System exceptions (SEs) and interrupt requests (IRQs) allow peripheral devices to suspend CPU operation in an orderly manner and force the CPU to start a service routine. Interrupt service routines are involved with the data exchange, status information, or control information between the CPU and the interrupting peripheral. When the service routine is completed, the CPU returns to the operation from which it was interrupted.

The eZ8 CPU supports both vectored and polled interrupt handling. For polled interrupts, the interrupt controller has no effect on operation.

For more information on interrupt servicing by the eZ8 CPU, refer to *eZ8 CPU User Manual (UM0128)*, available for download at www.zilog.com.

Interrupt and System Exception Vector Listing

Table 29 lists the SEs and the interrupts in order of priority. Reset and system exceptions always have priority over interrupts. The system exception and interrupt vectors are stored with the most significant byte (MSB) at the even Program Memory address and the least significant byte (LSB) at the following odd Program Memory address.

- **Note:** *Port interrupts are only available in those packages which support the associated port pins.*

Table 29. Reset, System Exception, and Interrupt Vectors in Order of Priority

Priority	Program Memory Vector Base Address	Programmable Priority?	Interrupt or Trap Source
Reset and System Exceptions			
	0002h	No	Reset
	0004h	No	Watchdog Timer (see Watchdog Timer on page 61)
	003AH	No	Primary Oscillator Fail Trap
	003CH	No	Watchdog Timer Oscillator Fail Trap
	0006h	No	Illegal Instruction Trap
Interrupts (maskable)			
Highest	0008h	Yes	PWM Timer
	000Ah	Yes	PWM Fault
	000Ch	Yes	ADC
	000Eh	Yes	Comparator output rising and falling edge
	0010h	Yes	Timer 0
	0012H	Yes	UART 0 receiver
	0014H	Yes	UART 0 transmitter
	0016H	Yes	SPI
	0018H	Yes	I ² C
	001AH	Yes	Reserved
	001CH	Yes	Port C0 with selectable rising or falling input edge
	001EH	Yes	Port B[3:0] rising and fall input edge
	0020h	Yes	Port A7/A3 with selectable rising or falling input edge
	0022H	Yes	Port A6/A2 with selectable rising or falling input edge
	0024H	Yes	Port A5/A1 with selectable rising or falling input edge
	0026H	Yes	Port A4/A0 with selectable rising or falling input edge
Lowest	0028H–0039H	N/A	Reserved

Architecture

[Figure 6](#) displays the block diagram of the interrupt controller.

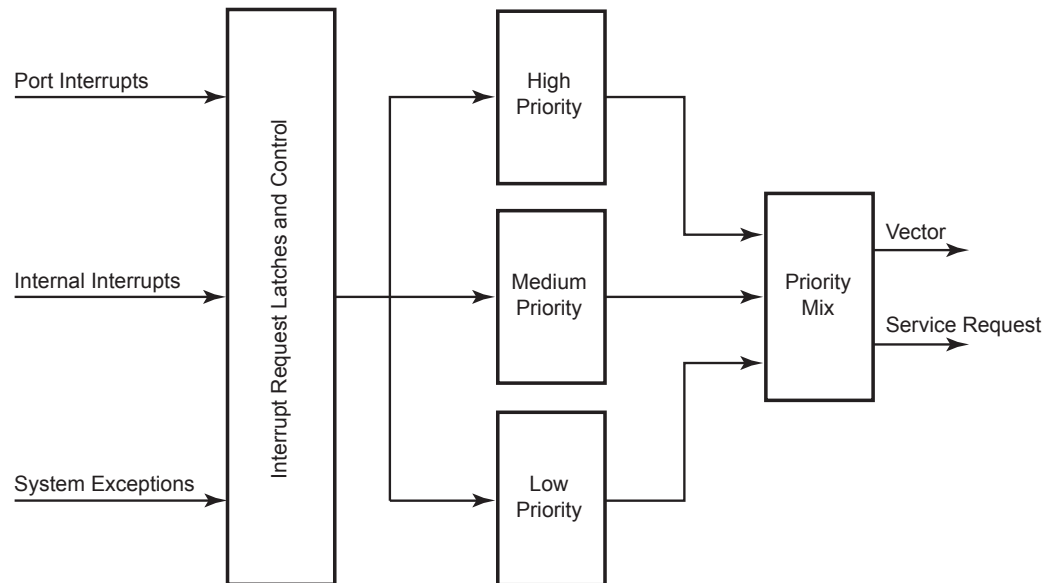

Figure 6. Interrupt Controller Block Diagram

Master Interrupt Enable

The master interrupt enable bit (IRQE) in the Interrupt Control register globally enables and disables interrupts.

Interrupts are globally enabled by any of the following actions:

- Execution of an Enable Interrupt (EI) instruction
- Execution of a Return from Interrupt (IRET) instruction
- Writing a 1 to the IRQE bit in the Interrupt Control register

Interrupts are globally disabled by any of the following actions:

- Execution of a Disable Interrupt (DI) instruction
- eZ8 CPU acknowledgement of an interrupt service request from the interrupt controller
- Writing a 0 to the IRQE bit in the Interrupt Control register
- Reset
- Execution of a Trap instruction
- Illegal Instruction trap

System Exceptions

The Z8FMC16100 Series Flash MCU supports multiple system exceptions. System exceptions are generated for the following events:

- Illegal Instruction trap
- Watchdog Timer interrupt
- Watchdog Timer RC oscillator failure
- Primary oscillator failure

System exceptions, excluding the WDT interrupt, are non-maskable and therefore cannot be disabled by the interrupt controller (setting `IRQE` to 0 has no effect).

Interrupt Vectors and Priority



Caution: *The interrupt controller supports three levels of interrupt priority. Level 3 interrupts are always higher priority than Level 2 interrupts. Level 2 interrupts are always higher priority than Level 1 interrupts. Within each interrupt priority level (Level 1, Level 2, or Level 3), priority is assigned as specified in [Table 29](#).*

Interrupt Assertion

When an interrupt request occurs, the corresponding bit in the Interrupt Request register is set. This bit is automatically cleared when the eZ8 CPU vectors to the Interrupt Service Routine (ISR). Writing a 0 to the corresponding bit in the Interrupt Request register also clears the interrupt request.

If an interrupt is disabled, software polls the appropriate interrupt request register bit and clear the bit directly. The following style of coding to clear bits in the Interrupt Request registers is not recommended. All incoming interrupts that are received between execution of the first LDX command and the last LDX command are lost.

The following code segment is an example of a poor coding style which results in lost interrupt requests:

```
LDX r0, IRQ0
AND r0, MASK
Q0, r0
```

To avoid missing interrupts, Zilog® recommends the following style of coding to clear bits in the Interrupt Request 0 register:

```
ANDX IRQ0, MASK
```

Software Interrupt Assertion

Program code can generate interrupts directly. Writing a 1 to the appropriate bit in the Interrupt Request register triggers an interrupt (assuming that interrupt is enabled). This bit is automatically cleared when the eZ8 CPU vectors to the ISR.

The following style of coding to generate software interrupts by setting bits in the Interrupt Request registers is not recommended. All incoming interrupts that are received between execution of the first LDX command and the last LDX command are lost.

The following code segment is an example of a poor coding style that results in lost interrupt requests:

```
LDX r0, IRQ0
OR r0, MASK
LDX IRQ0, r0
```

To avoid missing interrupts, Zilog® recommends the following style of coding to set bits in the Interrupt Request registers:

```
ORX IRQ0, MASK
```

Interrupt Control Register Definitions

The interrupt control registers enable individual interrupts, set interrupt priorities, and indicate interrupt requests.

Interrupt Request 0 Register

The Interrupt Request 0 (IRQ0) register (Table 30) stores the interrupt requests for both vectored and polled interrupts. When a request is presented to the interrupt controller, the corresponding bit in the IRQ0 register becomes 1. If interrupts are globally enabled (vectored interrupts), the interrupt controller passes an interrupt request to the eZ8 CPU. If interrupts are globally disabled (polled interrupts), the eZ8 CPU reads the Interrupt Request 0 register to determine if any interrupt requests are pending.

Table 30. Interrupt Request 0 Register (IRQ0)

BITS	7	6	5	4	3	2	1	0
FIELD	PWMI	FLTI	ADCI	CMPI	T0I	U0RXI	U0TXI	SPII
RESET	0	0	0	0	0	0	0	0
R/W	R/W	R/W	R/W	R/W	R/W	R/W	R/W	R/W
ADDR	FC0H							

Bit Position	Value (H)	Description
[7] PWMI	0	PWM Timer Interrupt Request No interrupt request is pending for the PWM.
	1	An interrupt request from the PWM is awaiting service.
[6] FLTI	0	Fault Interrupt Request. The fault interrupt is generated in the PWM module and originates from the Fault0 pin, Fault1 pin or the Comparator output. An interrupt enable for each of these sources exists in the PWM module. No Fault interrupt request is pending.
	1	A Fault interrupt request is awaiting service.
[5] ADCI	0	ADC Interrupt Request No interrupt request is pending for the Analog-to-Digital Converter.
	1	An interrupt request from the Analog-to-Digital Converter is awaiting service.
[4] CMPI	0	Comparator Interrupt Request No interrupt request is pending for the Comparators.
	1	An interrupt request from the Comparators is awaiting service.
[3] T0I	0	Timer 0 Interrupt Request No interrupt request is pending for Timer 0.
	1	An interrupt request from Timer 0 is awaiting service.
[2] U0RXI	0	UART 0 Receiver Interrupt Request No interrupt request is pending for the UART 0 receiver.
	1	An interrupt request from the UART 0 receiver is awaiting service.
[1] U0TXI	0	UART 0 Transmitter Interrupt Request No interrupt request is pending for the UART 0 transmitter.
	1	An interrupt request from the UART 0 transmitter is awaiting service.
[0] SPII	0	SPI Interrupt Request No interrupt request is pending for the SPI.
	1	An interrupt request from the SPI is awaiting service.

Interrupt Request 1 Register

The Interrupt Request 1 (IRQ1) register ([Table 31](#)) stores interrupt requests for both vectored and polled interrupts. When a request is presented to the interrupt controller, the corresponding bit in the IRQ1 register becomes 1. If the interrupts are globally enabled (vectored interrupts), the interrupt controller passes an interrupt request to the eZ8 CPU.

If the interrupts are globally disabled (polled interrupts), the eZ8 CPU reads the Interrupt Request 1 register to determine if any interrupt requests are pending.

Table 31. Interrupt Request 1 Register (IRQ1)

BITS	7	6	5	4	3	2	1	0
FIELD	I2CI	Reserved	PC0I	PBI	PA73I	PA62I	PA51I	PA40I
RESET	0	0	0	0	0	0	0	0
R/W	R/W	R	R/W	R/W	R/W	R/W	R/W	R/W
ADDR	FC3H							

Bit Position	Value (H)	Description
[7] I2CI	0	I2C Interrupt Request No interrupt request is pending for I2C.
	1	An interrupt request from I2C is awaiting service.
[5] PC0I	0	PC0 Interrupt Request—Logic in the Port C GPIO module selects either the rising or falling edge. No interrupt request is pending for PC0.
	1	An interrupt request from PC0 is awaiting service.
[4] PBI	0	PB3–PB0 Interrupt Request No interrupt request is pending for any PB3–PB0.
	1	An interrupt request from PB3–PB0 is awaiting service.
[3] PA73I	0	PA7 or PA3 Interrupt Request—Logic in the Port A GPIO module selects either PA7 or PA3 and either rising or falling edge. No interrupt request is pending for PA7 or PA3
	1	An interrupt request from PA7 or PA3 is awaiting service.
[2] PA62I	0	PA6 or PA2 Interrupt Request—Logic in the Port A GPIO module selects either PA6 or PA2 and either rising or falling edge. No interrupt request is pending for PA6 or PA2
	1	An interrupt request from PA6 or PA2 is awaiting service.
[1] PA51I	0	PA5 or PA1 Interrupt Request—Logic in the Port A GPIO module selects either PA5 or PA1 and either rising or falling edge. No interrupt request is pending for PA5 or PA1
	1	An interrupt request from PA5 or PA1 is awaiting service.

Bit Position	Value (H)	Description
[0] PA40I	0	PA4 or PA0 Interrupt Request—Logic in the Port A GPIO module selects either PA4 or PA0 and either rising or falling edge. No interrupt request is pending for PA4 or PA0
	1	An interrupt request from PA4 or PA0 is awaiting service.

IRQ0 Enable High and Low Bit Registers

The IRQ0 Enable High and Low Bit registers, shown in [Table 33](#) and [Table 34](#), form a priority encoded enabling for interrupts in the Interrupt Request 0 register. Priority is generated by setting bits in each register. [Table 32](#) describes the priority control for IRQ0.

Table 32. IRQ0 Enable and Priority Encoding

IRQ0ENH[x]	IRQ0ENL[x]	Priority	Description
0	0	Disabled	Disabled
0	1	Level 1	Low
1	0	Level 2	Nominal
1	1	Level 3	High

Note: x indicates the register bits from 0 through 7.

Table 33. IRQ0 Enable High Bit Register (IRQ0ENH)

BITS	7	6	5	4	3	2	1	0
FIELD	PWMENH	FLTENH	ADCENH	CMPENH	T0ENH	U0RENH	U0TENH	SPIENH
RESET	0	0	0	0	0	0	0	0
R/W	R/W	R/W	R/W	R/W	R/W	R/W	R/W	R/W
ADDR	FC1H							

PWMENH—PWM Interrupt Request Enable High Bit
 FLTENH—Fault Interrupt Request Enable High Bit
 ADCENH—ADC Interrupt Request Enable High Bit
 CMPENH—Comparator Interrupt Request Enable High Bit
 T0ENH—Timer 1 Interrupt Request Enable High Bit
 U0RENH—UART 0 Receive Interrupt Request Enable High Bit
 U0TENH—UART 0 Transmit Interrupt Request Enable High Bit
 SPIENH—SPI Interrupt Request Enable High Bit

Table 34. IRQ0 Enable Low Bit Register (IRQ0ENL)

BITS	7	6	5	4	3	2	1	0
FIELD	PWMENL	FLTENL	ADCENL	CMPENL	T0ENL	U0RENL	U0TENL	SPIENL
RESET	0	0	0	0	0	0	0	0
R/W	R/W	R/W	R/W	R/W	R/W	R/W	R/W	R/W
ADDR	FC2H							

PWMENL—PWM Interrupt Request Enable Low Bit
 FLTENL—Fault Interrupt Request Enable Low Bit
 ADCENL—ADC Interrupt Request Enable Low Bit
 CMPENL—Comparator Interrupt Request Enable Low Bit
 T0ENL—Timer 0 Interrupt Request Enable Low Bit
 U0RENL—UART 0 Receive Interrupt Request Enable Low Bit
 U0TENL—UART 0 Transmit Interrupt Request Enable Low Bit
 SPIENL—SPI Interrupt Request Enable Low Bit

IRQ1 Enable High and Low Bit Registers

The IRQ1 Enable High and Low Bit registers, shown in [Table 36](#) and [Table 37](#), form a priority encoded enabling for interrupts in the Interrupt Request 1 register. Priority is generated by setting bits in each register. [Table 35](#) describes the priority control for IRQ1.

Table 35. IRQ1 Enable and Priority Encoding

IRQ1ENH[x]	IRQ1ENL[x]	Priority	Description
0	0	Disabled	Disabled
0	1	Level 1	Low
1	0	Level 2	Nominal
1	1	Level 3	High

Note: x indicates the register bits from 0 through 7.

Table 36. IRQ1 Enable High Bit Register (IRQ1ENH)

BITS	7	6	5	4	3	2	1	0
FIELD	I2CENH	Reserved	PC0ENH	PBENH	PA73ENH	PA62ENH	PA51ENH	PA40ENH
RESET	0	0	0	0	0	0	0	0
R/W	R/W	R	R/W	R/W	R/W	R/W	R/W	R/W
ADDR	FC4H							

Bit Position	Name	Description
[7]	I2CENH	I2C Interrupt Request Enable High Bit
[5]	PC0ENH	Port C0Interrupt Request Enable High Bit
[4]	PBENH	Port B[3:0] Interrupt Request Enable High Bit
[3]	PA73ENH	Port A73 Interrupt Request Enable High Bit
[2]	PA62ENH	Port A62 Interrupt Request Enable High Bit
[1]	PA51ENH	Port A51 Interrupt Request Enable High Bit
[0]	PA40ENH	Port A40 Interrupt Request Enable High Bit

Table 37. IRQ1 Enable Low Bit Register (IRQ1ENL)

BITS	7	6	5	4	3	2	1	0
FIELD	I2CENL	Reserved	PC0ENL	PBENL	PA73ENL	PA62ENL	PA51ENL	PA40ENL
RESET	0	0	0	0	0	0	0	0
R/W	R/W	R	R/W	R/W	R/W	R/W	R/W	R/W
ADDR	FC5H							

Bit Position	Name	Description
[7]	I2CENL	I2C Interrupt Request Enable Low Bit
[5]	PC0ENL	Port C0Interrupt Request Enable Low Bit
[4]	PBENL	Port B[3:0] Interrupt Request Enable Low Bit
[3]	PA73ENL	Port A73 Interrupt Request Enable Low Bit
[2]	PA62ENL	Port A62 Interrupt Request Enable Low Bit
[1]	PA51ENL	Port A51 Interrupt Request Enable Low Bit
[0]	PA40ENL	Port A40 Interrupt Request Enable Low Bit

Interrupt Control Register

The Interrupt Control (IRQCTL) register ([Table 38](#)) contains the Master Enable Bit (IRQE) for all interrupts.

Table 38. Interrupt Control Register (IRQCTL)

BITS	7	6	5	4	3	2	1	0
FIELD	IRQE	Reserved						
RESET	0	0	0	0	0	0	0	0
R/W	R/W	R	R	R	R	R	R	R
ADDR	FCFH							

IRQE—Interrupt Request Enable

This bit is set to 1 by execution of an EI (Enable Interrupts) or IRET (Interrupt Return) instruction, or by a direct register write of a 1 to this bit. It is reset to 0 by executing a DI instruction, the eZ8 CPU acknowledgement of an interrupt request or system exception, Reset, or direct register write to 0.

0 = Interrupts are disabled.

1 = Interrupts are enabled.

Reserved—Must be 0.

Watchdog Timer

The Watchdog Timer (WDT) helps protect against corrupted or unreliable software and other system-level problems which may place the Z8FMC16100 Series Flash MCU into unsuitable operating states. The WDT includes the following features:

- On-chip RC oscillator
- A selectable timeout response: Reset or System Exception
- 16-bit programmable timeout value

Operation

The WDT is a retriggerable one-shot timer that resets or interrupts the Z8FMC16100 Series Flash MCU when the WDT reaches its terminal count. The WDT uses its own dedicated on-chip RC oscillator as its clock source. The WDT has only two modes of operation—ON and OFF. Once enabled, it always counts and must be refreshed to prevent a timeout. An enable can be performed by executing the WDT instruction or by setting the WDT_AO Option Bit. The WDT_AO bit enables the WDT to operate all the time, even if a WDT instruction has not been executed.

To minimize power consumption, the RC oscillator can be disabled. The RC oscillator is disabled by clearing the WDTEN bit in the [Oscillator Control Register](#). If the RC oscillator is disabled, the WDT will not operate.

The WDT is a 16-bit reloadable downcounter that uses two 8-bit registers in the eZ8 CPU register space to set the reload value. The nominal WDT timeout period is calculated by the following equation:

$$\text{WDT Timeout Period (ms)} = \frac{\text{WDT Reload Value}}{10}$$

where the WDT reload value is assigned by $\{\text{WDTH}[7:0], \text{WDTL}[7:0]\}$ and the typical Watchdog Timer RC oscillator frequency is 10 kHz. You must consider system requirements while selecting the time out delay. [Table 39](#) provides information on approximate timeout delays for the default and maximum WDT reload values.

Table 39. Watchdog Timer Approximate Timeout Delays

WDT Reload Value (Hex)	WDT Reload Value (Decimal)	Approximate Timeout Delay (with 10 kHz Typical WDT Oscillator Frequency)	
		Typical	Description
0400	1024	102 ms	Reset default value timeout delay.
FFFF	65,536	6.55 s	Maximum timeout delay.

Watchdog Timer Refresh

When first enabled, the WDT is loaded with the value in the Watchdog Timer Reload registers. The WDT then counts down to 0000h unless a WDT instruction is executed by the eZ8 CPU. Execution of the WDT instruction causes the downcounter to be reloaded with the WDT Reload value stored in the Watchdog Timer Reload registers. Counting resumes following the reload operation.

When the Z8FMC16100 Series Flash MCU is operating in DEBUG mode (through the OCD), the WDT is continuously refreshed to prevent spurious WDT timeouts.

Watchdog Timer Timeout Response

The WDT times out when the counter reaches 0000h. A timeout of the WDT generates either a system exception or a Reset. The WDT_RES Option Bit determines the timeout response of the WDT. For information on programming of the WDT_RES Option Bit, see [Option Bits](#) on page 221.

WDT System Exception in Normal Operation

If configured to generate a system exception when a timeout occurs, the WDT issues an exception request to the interrupt controller. The eZ8 CPU responds to the request by fetching the System Exception vector and executing code from the vector address. After timeout and system exception generation, the WDT is reloaded automatically and continues counting.

WDT System Exception in STOP Mode

If configured to generate a system exception when a timeout occurs and the Z8FMC16100 Series Flash MCU is in STOP mode, the WDT automatically initiates a Stop Mode Recovery and generates a system exception request. Both the WDT status bit and the STOP bit in the [Reset Status and Control Register](#) on page 27 are set to 1 following WDT timeout in STOP mode. For more information, see [Reset and Stop Mode Recovery](#) on page 21.

Following completion of the Stop Mode Recovery the eZ8 CPU responds to the system exception request by fetching the System Exception vector and executing code from the vector address.

WDT Reset in Normal Operation

If configured to generate a Reset when a timeout occurs, the WDT forces the device into the Reset state. The WDT status bit in the [Reset Status and Control Register](#) is set to 1. For more information on Reset and the WDT status bit, see [Reset and Stop Mode Recovery](#) on page 21. Following a Reset sequence, the WDT Counter is initialized with its reset value.

WDT Reset in Stop Mode

If enabled in STOP mode and configured to generate a Reset when a timeout occurs and the device is in STOP mode, the Watchdog Timer initiates a Stop Mode Recovery. Both the WDT status bit and the STOP bit in the [Reset Status and Control Register](#) are set to 1 following WDT timeout in STOP mode. For more information, see [Reset and Stop Mode Recovery](#) on page 21.

Watchdog Timer Reload Unlock Sequence

Writing the unlock sequence to the Watchdog Timer Reload High (WDTH) register address unlocks the two Watchdog Timer Reload registers (WDTH and WDTL) to allow changes to the timeout period. These write operations to the WDTH register address produce no effect on the bits in the WDTH register. The locking mechanism prevents spurious writes to the Reload registers. The following sequence is required to unlock the Watchdog Timer Reload registers (WDTH and WDTL) for write access:

1. Write 55H to the Watchdog Timer Reload High register (WDTH).
2. Write AAH to the Watchdog Timer Reload High register (WDTH).
3. Write the appropriate value to the Watchdog Timer Reload High register (WDTH).
4. Write the appropriate value to the Watchdog Timer Reload Low register (WDTL).

All steps of the Watchdog Timer Reload Unlock sequence must be written in the order listed above. The value in the Watchdog Timer Reload registers is loaded into the counter every time a WDT instruction is executed.

Watchdog Timer Reload High and Low Byte Registers

The Watchdog Timer Reload High and Low Byte (WDTH, WDTL) registers ([Table 40](#) through [Table 41](#)) form the 16-bit reload value that is loaded into the Watchdog Timer when a WDT instruction executes. The 16-bit reload value is {WDTH[7:0], WDTL[7:0]}. Write to these registers following the unlock sequence sets the appropriate Reload Value. Reading from these registers returns the current WDT count value.

Table 40. Watchdog Timer Reload High Byte Register (WDTH)

BITS	7	6	5	4	3	2	1	0
FIELD	WDTH							
RESET	04H							
R/W	R/W*							
ADDR	FF2H							

R/W* - Read returns the current WDT count value. Write sets the appropriate Reload Value.

WDTH—WDT Reload High Byte

Most significant byte (MSB), Bits[15:8], of the 16-bit WDT reload value.

Table 41. Watchdog Timer Reload Low Byte Register (WDTL)

BITS	7	6	5	4	3	2	1	0
FIELD	WDTL							
RESET	00H							
R/W	R/W*							
ADDR	FF3H							

R/W* - Read returns the current WDT count value. Write sets the appropriate Reload Value.

WDTL—WDT Reload Low

Least significant byte (LSB), Bits[7:0], of the 16-bit WDT reload value.

Pulse Width Modulator

The Z8FMC16100 Series Flash MCU includes a Pulse-Width Modulator (PWM) optimized for Motor Control applications. The PWM features include:

- 6 independent PWM outputs or 3 complementary PWM output pairs
- Programmable deadband insertion for complementary output pairs
- Edge-aligned or center-aligned PWM signal generation
- PWM OFF state is option-bit-programmable
- PWM outputs driven to OFF state on System Reset
- Asynchronous disabling of PWM outputs on system fault; outputs are forced to OFF state
- FAULT inputs generate pulse-by-pulse or hard shutdown
- 12-bit reload counter with 1-, 2-, 4-, or 8-bit programmable clock prescaler
- High current source and sink on all PWM outputs
- When outputs are disabled, PWM pairs are used as general-purpose inputs
- ADC synchronized with PWM period
- Narrow pulse suppression with programmable threshold

Architecture

The PWM unit consists of a master timer to generate the modulator time base and six independent compare registers to set the pulse-width modulation for each output. The six outputs are designed to provide control signals for inverter drive circuits. The outputs are grouped into pairs consisting of a High driver and a Low driver output. The output pairs are programmable to operate independently or as complementary signals. In complementary output mode, a programmable dead time is inserted to ensure non-overlapping signal transitions. The master count and compare values feed into modulator logic that generates the proper transitions in the output states. Output polarity and fault/OFF state control logic allows programming of the default OFF states, which forces the outputs to a safe state in the event a fault in the motor drive is detected.

Figure 7 displays the architecture of the PWM modulator.

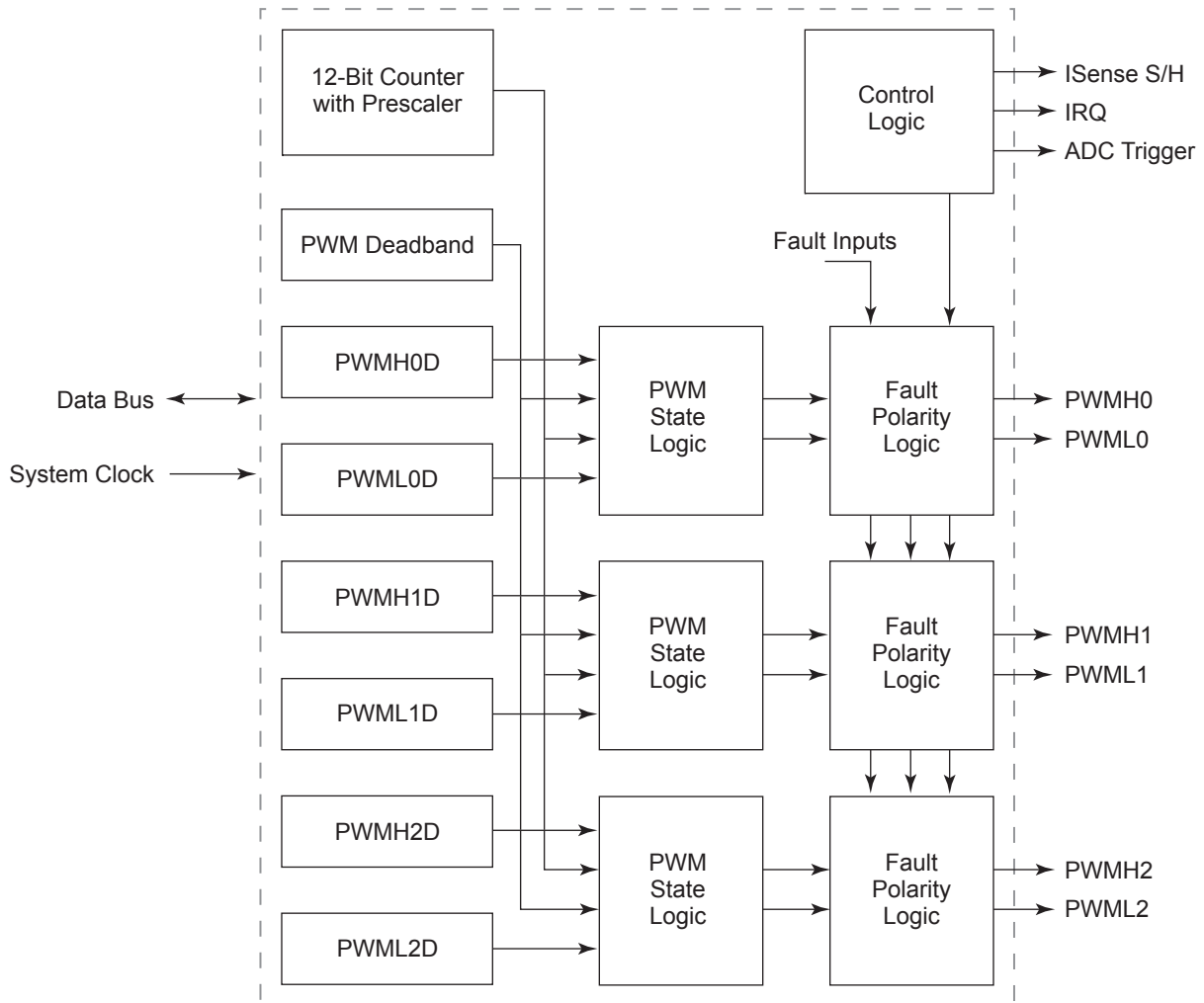

Figure 7. PWM Block Diagram

PWM Option Bits

To protect the configuration of critical PWM parameters, the settings to enable the output channels, and the default OFF state, are maintained as user option bits. These values are set when the user program code is written to the part, and cannot be changed by software. See [Option Bits](#) on page 221.

PWM Off State and Output Polarity

The default OFF state and the polarity of the PWM outputs are controlled by the `PWMHI` and `PWMLO` option bits. The `PWMHI` option controls the OFF state and the polarity for the PWM High outputs H0, H1, and H2. The `PWMLO` option controls the OFF state and the polarity for the Low outputs L0, L1, and L2.

The OFF state is the value programmed in the option bit. For example, programming `PWMHI` to a 1 sets the OFF state of PWMH0, H1, and H2 to a High logic value and the active state a Low logic value. Conversely, programming `PWMHI` to a 0 causes the OFF state to be a Low logic value. `PWMLO` is programmed in a similar manner.

The relative polarity of the PWM channel pairs is controlled by the `POLx` bits in the PWM Control 1 register (`PWMCTL1`). These bits do not affect the OFF state programmed by the option bits. Setting these bits inverts the High and Low of the selected channels. The relative channel polarity controls the order in which the signals of a given PWM pair toggle. If a `POLx` bit is reset to zero, the High will first go active at the start of a PWM period. Alternately, if the bit is set, the Low will go active first. A switching of the `POLx` bits is synchronized with the PWM reload event (see below). In complementary mode, the switch is additionally delayed until the end of the programmed deadband time.

PWM Channel Pair Enable

Following a POR, the PWM pins enter a high-impedance state. As the internal reset proceeds, the PWM outputs are forced to the OFF state as determined by the `PWMHI` and `PWMLO` OFF state option bits.

The `PWM0EN`, `PWM1EN`, and `PWM2EN` option bits enable the PWM0, PWM1, and PWM2 output pairs, respectively. If a PWM channel pair is not enabled, it remains in a high-impedance state after reset and can be used as a general-purpose input.

PWM Reload Event

To prevent erroneous PWM pulse-widths and periods, registers that control the timing of the output are buffered. Buffering causes all of the PWM compare values to update at the same time. In other words, the registers that control the duty cycle and clock source prescaler only take effect upon a PWM reload event. A PWM reload event can be configured to occur at the end of each PWM period, or only every 2, 4, or 8 PWM periods by setting the `RELFREQ` bits in the PWM Control 1 register (`PWMCTL1`). The software must indicate that all new values are ready by setting the `READY` bit in the PWM Control 0 register (`PWMCTL0`) to 1. After this `READY` bit has been set to 1, the buffered values take effect at the next reload event.

PWM Prescaler

The prescaler allows the PWM clock signal to be decreased by factors of 1, 2, 4, or 8 with respect to the system clock. The `PRES[1:0]` bit field in the PWM Control 1 register (PWMCTL1) controls prescaler operation. This 2-bit `PRES` field is buffered so that the prescale value only changes upon a PWM reload event.

PWM Period and Count Resolution

The PWM counter operates in two modes to allow edge-aligned outputs and center-aligned outputs. Figure 8 and Figure 9 display edge-aligned and center-aligned PWM outputs. The period of the PWM outputs (PERIOD) is determined by which mode the PWM counter is operating. The active time of a PWM output is determined by the programmed duty cycle (PWMDC) and the programmed deadband time (PWMDB).

The sections that follows these two figures describe the PWM timer modes and the registers that control the duty cycle and deadband time.

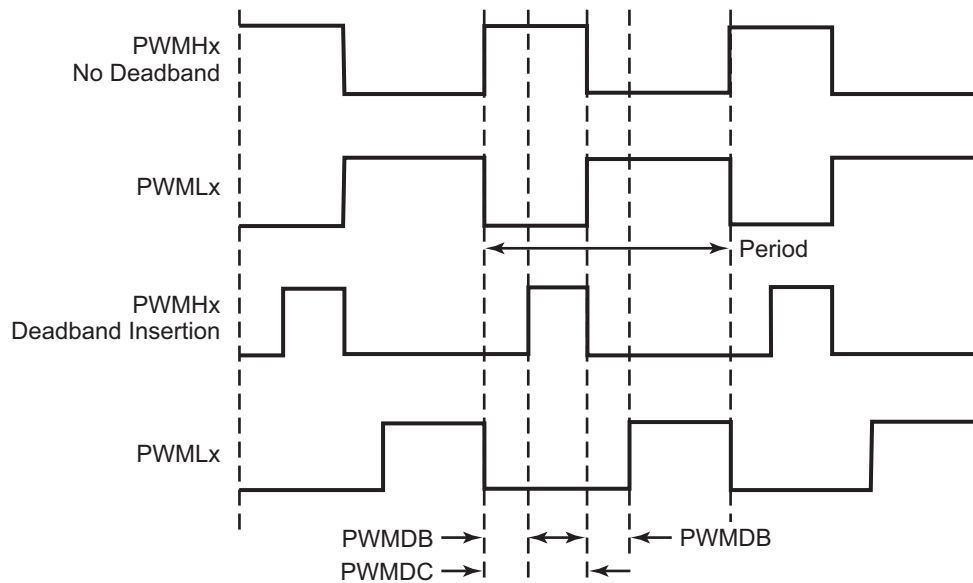

Figure 8. Edge-Aligned PWM Output

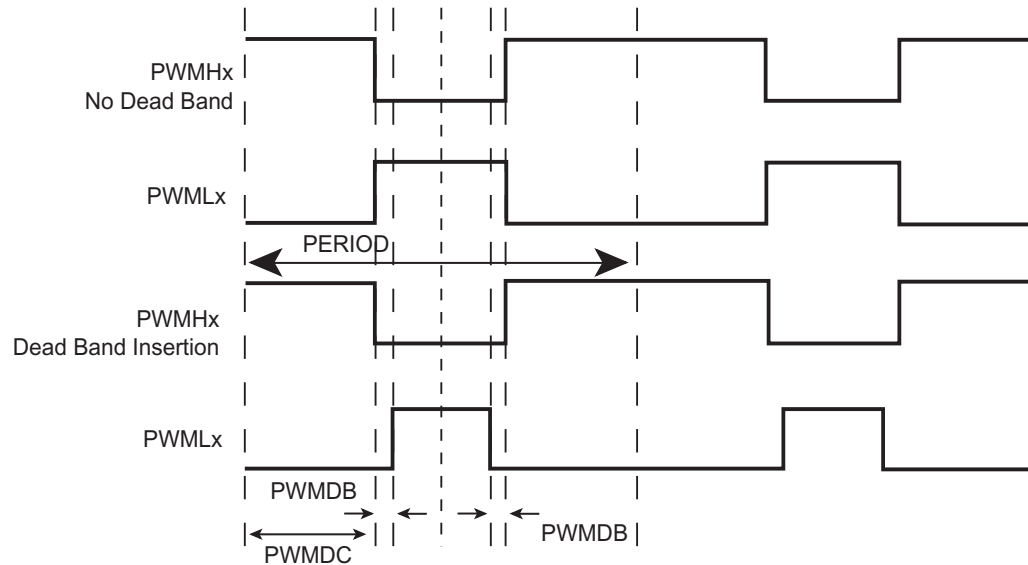

Figure 9. Center-Aligned PWM Output

EDGE-ALIGNED Mode

In EDGE-ALIGNED PWM mode, a 12-bit up counter creates the PWM period with a minimum resolution equal to the PWM clock source period. The counter counts up to the reload value, resets to 000h, and then resumes counting.

$$\text{EDGE-ALIGNED PWM Mode Period} = \frac{\text{Prescaler} \times \text{Reload Value}}{f_{\text{SYSTEMCLK}}}$$

CENTER-ALIGNED Mode

In CENTER-ALIGNED PWM mode, a 12-bit up/down counter creates the PWM period with a minimum resolution equal to twice the PWM clock source period. The counter counts up to the reload value and then counts down to 0.

$$\text{CENTER-ALIGNED PWM Mode Period} = \frac{2 \times \text{Prescaler} \times (\text{Reload Value})}{f_{\text{SYSTEMCLK}}}$$

PWM Duty Cycle Registers

The PWM Duty Cycle registers (PWMH0D, PWML0D, PWMH1D, PWML1D, PWMH2D, and PWML2D) contain a 16-bit signed value, in which bit 15 is the sign bit. The Duty Cycle value is compared to the current 12-bit unsigned PWM count value. If the PWM Duty Cycle value is set less than or equal to 0, the PWM output is deasserted for the full PWM period. If the PWM Duty Cycle value is set to a value greater than the PWM reload value, the PWM output is asserted for the full PWM period.

Independent and Complementary PWM Outputs

The six PWM outputs are configured to operate independently or as three complementary pairs. Operation as six independent PWM channels is enabled by setting the `INDEN` bit in PWM Control 1 register (PWMCTL1). The `PWEN` bit must be cleared to alter this bit. In independent mode, each PWM output uses its own PWM duty cycle value.

When configured to operate as three complementary pairs, the PWM duty cycle values PWMH0D, PWMH1D, and PWMH2D control the modulator output. In complementary output mode, deadband time is also inserted.

The `POLx` bits in the PWM Control 1 register (PWMCTL1) select the relative polarity of the High and Low signals. As displayed in [Figure 8](#) and [Figure 9](#), when the `POLx` bits are cleared to 0, the High PWM output will start in the ON state and transition to the OFF state when the PWM timer count reaches the programmed duty cycle. The Low PWM value starts in the OFF state and transitions to the ON state as the PWM timer count reaches the value in the associated duty cycle register. Setting the `POLx` causes the High output to start in the OFF state and the Low output to start in the ON state.

Manual Off-State Control of PWM Output Channels

Each PWM output is controlled directly by the modulator logic or set to the OFF state. To manually set the PWM outputs to the OFF state, set the `OUTCTL` bit and the associated `OUTx` bits in the PWM Output Control register (PWMOUT). OFF state control operates individually by channel. For example, suppressing the single output of a pair allows the complementary channel to continue operating. Similarly, if outputs are operating independently, disabling one output channel has no effect on the other PWM outputs.

Deadband Insertion

When PWM outputs are configured to operate as complementary pairs, an 8-bit deadband value can be defined in the PWM Deadband register (PWMDDB). Inserting deadband time causes the modulator to separate the deassertion of one PWM signal from the assertion of its complement. This separation is essential for many motor control applications in that it prevents simultaneous turn-on of the High and Low drive transistors. The deadband counter directly counts system clock cycles and is unaffected by PWM prescaler settings. The

width of this deadband is attributed to the number of system clock cycles specified in the PWM Deadband register (PWMDDB). The minimum deadband duration is one system clock, and the maximum duration is 255 system clocks. During the deadband period, both PWM outputs of a complementary pair are deasserted. The generation of deadband time does not alter the PWM period; instead, the deadband time is subtracted from the active time of the PWM outputs. [Figure 8](#) and [Figure 9](#) display the effect of deadband insertion on the PWM output.

Minimum PWM Pulse Width Filter

The PWM modulator is capable of producing pulses as narrow as a single system clock cycle in width. As the response time of external drive circuits can be slower than the period of a system clock, a filter is implemented to enforce a minimum-width pulse on the PWM output pins. All output pulses, whether High or Low, must be at least the minimum number of PWM clock cycles (for more details, see [PWM Prescaler](#) on page 68) in width as specified in the PWM Minimum Pulse Width Filter (PWMMPF) register. If the expected pulse width is less than the threshold, the associated PWM output does not change state until the duty cycle value has changed sufficiently to allow pulse generation of an acceptable width. The minimum pulse width filter also accounts for the duty cycle variation caused by the deadband insertion. The PWM output pulse is filtered even if the programmed duty cycle is greater than the threshold, but the pulse width decrease because of deadband insertion causes the pulse to be too narrow. The pulse width filter value is calculated as:

$$\text{Roundup (PWMMPF)} = \frac{T_{\text{MINPULSEOUT}}}{T_{\text{SYSTEMCLOCK}} \times \text{PWM}_{\text{PRESCALER}}}$$

where $T_{\text{MINPULSEOUT}}$ is the shortest allowed pulse width on the PWM outputs, in seconds.

The PWM Minimum Pulse Width Filter register can only be written when the PWEN bit is cleared. Values written to this register when PWEN is set will be ignored.

Synchronization of PWM and Analog-to-Digital Converter

The ADC on the Z8FMC16100 Series Flash MCU can be synchronized with the PWM period. Enabling the PWM ADC trigger causes the PWM to generate an ADC conversion signal at the end of each PWM period. Additionally, in center-aligned mode, the PWM generates a trigger at the center of the period. Setting the ADCTRIG bit in the PWM Control 0 register (PWMCTL0) enables ADC synchronization.

PWM Timer and Fault Interrupts

The PWM generates interrupts to the eZ8 CPU on any of the following events:

PWM Reload—The interrupt is generated at the end of PWM period, when a PWM register reload occurs (the `READY` bit is set).

PWM Fault—A fault condition is indicated by asserting any of the `FAULT` pins or by the assertion of the comparator.

Fault Detection and Protection

The Z8FMC16100 Series Flash MCU contains hardware and software fault controls that allow rapid deassertion of all enabled PWM output signals. A logic Low on an external fault pin (`FAULT0` or `FAULT1`), or the assertion of the overcurrent comparator, forces the PWM outputs to a predefined OFF state.

Similar deassertion of the PWM outputs can be accomplished in software by writing to the `PWMOFF` bit in the PWM Control 0 register. The PWM counter continues to operate while the outputs are deasserted (made inactive) due to one of these fault conditions.

The fault inputs can be individually enabled through the PWM Fault Control register. If a fault condition is detected and the source is enabled, a fault interrupt is generated. The PWM Fault Status register (`PWMFSTAT`) is read to determine which fault source has caused the interrupt.

After a fault has been detected, and after the PWM outputs are disabled, modulator control of the PWM outputs can be re-enabled either by software, or by deassertion of the `FAULT` input signal. Selection of either method is made through the PWM Fault Control register (`PWMFCTL`). Configuration of the fault modes and re-enable methods allows pulse-by-pulse limiting and hard shutdown. When configured in automatic restart mode, the PWM outputs are reengaged at beginning of the next PWM cycle (the master timer value is equal to 0) if all fault signals are deasserted. In a software-controlled restart, all fault inputs must be deasserted and all fault flags cleared.

The fault input pin is Schmitt-triggered. The input signal from the pin and comparators, pass though an analog filter to reject high-frequency noise.

The logic path from the fault sources to the PWM outputs is asynchronous, which ensures that the fault inputs forces the PWM outputs to their OFF state, even if the system clock is stopped.

► **Note:** *After Reset the Fault mechanism is active, disable the Fault source for normal port input operation.*

PWM Operation in CPU Halt Mode

When eZ8 CPU is operating in HALT mode, the PWM continues to operate, if enabled. To minimize the current in HALT mode, the PWM must be disabled by clearing the PWMEN bit to 0.

PWM Operation in CPU STOP Mode

When the eZ8 CPU is operating in STOP mode, the PWM is disabled, as the system clock ceases to operate in STOP mode. The PWM outputs remain in the same state as they were prior to entering STOP mode. In normal operation, the PWM outputs must be disabled by the software prior to the CPU entering STOP mode. A fault condition detected in STOP mode forces the PWM outputs to a predefined OFF state.

Observing the State of PWM Output Channels

The logic value of the PWM outputs can be sampled by reading the PWMIN register. If a PWM channel pair is disabled (an option bit is not set), the associated PWM outputs are forced to high-impedance, and can be used as general-purpose inputs.

PWM High and Low Byte Registers

The PWM High and Low Byte (PWMH and PWML) registers, shown in [Table 42](#) and [Table 43](#), contain the current 12-bit PWM count value. Reads from PWMH cause the value in PWML to be stored in a temporary holding register. A read from PWML always returns this temporary register value.



Caution: *Writing to the PWM High and Low Byte registers while the PWM is enabled is not recommended. There are no temporary holding registers for Write operations, so simultaneous 12-bit Writes are not possible.*

If either the PWM High register or Low Byte register are written during counting, the 8-bit written value is placed in the counter (High or Low byte) at the next clock edge. The counter continues counting from the new value.

Table 42. PWM High Byte Register (PWMH)

BITS	7	6	5	4	3	2	1	0
FIELD	Reserved				PWMH			
RESET	0H				0H			
R/W	R/W				R/W			
ADDR	F2CH							

Table 43. PWM Low Byte Register (PWML)

BITS	7	6	5	4	3	2	1	0
FIELD	PWML							
RESET	00H							
R/W	R/W							
ADDR	F2DH							

PWMH and PWML—PWM High and Low Bytes

These 2 bytes, {PWMH[3:0], PWML[7:0]}, contain the current 12-bit PWM count value.

PWM Reload High and Low Byte Registers

The PWM Reload High and Low Byte (PWMRH and PWMRL) registers (Table 44 and Table 45) store a 12-bit reload value, {PWMRH[3:0], PWMRL[7:0]}. The PWM reload value is held in buffer registers. The PWM reload value written to the buffer registers is not used by the PWM generator until the next PWM reload event occurs. Reads from these registers always return the values from the buffer registers.

$$\text{Edge-Aligned PWM Mode Period} = \frac{\text{Prescaler x Reload Value}}{f_{\text{PWMCLK}}}$$

$$\text{Center-Aligned PWM Mode Period} = \frac{2 \times \text{Prescaler x Reload Value}}{f_{\text{PWMCLK}}}$$

Table 44. PWM Reload High Byte Register (PWMRH)

BITS	7	6	5	4	3	2	1	0
FIELD	Reserved				PWMRH			
RESET	0H				FH			
R/W	R/W				R/W			
ADDR	F2EH							

Table 45. PWM Reload Low Byte Register (PWMRL)

BITS	7	6	5	4	3	2	1	0
FIELD	PWMRL							
RESET	FF							
R/W	R/W							
ADDR	F2FH							

PWMRH and PWMRL—PWM Reload Register High and Low

These two bytes form the 12-bit Reload value, {PWMRH[3:0], PWMRL[7:0]}. This value sets the PWM period.

PWM 0–2 Duty Cycle High and Low Byte Registers

The PWM 0–2 H/L Duty Cycle High and Low Byte (PWMxDH and PWMxDL) registers, (Table 46 and Table 47) set the duty cycle of the PWM signal. This 14-bit signed value is compared to the PWM count value to determine the PWM output. Reads from these registers always return the values from the temporary holding registers. The PWM duty cycle value is not used by the PWM generator until the next PWM reload event occurs.

$$\text{PWM Duty Cycle} = \frac{\text{PWM Duty Cycle Value}}{\text{PWM Reload Value}}$$

Writing a negative value (DUTYH[7] = 1) forces the PWM to be OFF for the full PWM period. Writing a positive value greater than the 12-bit PWM reload value forces the PWM to be ON for the full PWM period.

Table 46. PWM 0-2 H/L Duty Cycle High Byte Register (PWMHxDH, PWMLxDH)

BITS	7	6	5	4	3	2	1	0
FIELD	SIGN	Reserved			DUTYH			
RESET	0	00			0_0000			
R/W	R/W	R/W			R/W			
ADDR	F30H, F32H, F34H, F36H, F38H, F3AH							

Table 47. PWM 0-2 H/L Duty Cycle Low Byte Register (PWMHxDL, PWMLxDL)

BITS	7	6	5	4	3	2	1	0
FIELD	DUTYL							
RESET	00H							
R/W	R/W							
ADDR	F31H, F33H, F35H, F37H, F39H, F3BH							

Bit Position	Value (H)	Description
[7] SIGN	0	Duty Cycle Sign Duty Cycle is a positive two's complement number.
	1	Duty Cycle is a negative two's complement number. Output is forced to the off-state.
[6:0], [7:0] DUTYH and DUTYL		PWM Duty Cycle High and Low Bytes These two bytes, {DUTYH[7:0], DUTYL[7:0]}, form a 14-bit signed value (Bits 5 and 6 of the High Byte are always 0). The value is compared to the current 12-bit PWM count.

PWM Control 0 Register

The PWM Control 0 (PWMCTL0) register ([Table 48](#)) controls PWM operation.

Table 48. PWM Control 0 Register (PWMCTL0)

BITS	7	6	5	4	3	2	1	0
FIELD	PWMOFF	OUTCTL	ALIGN	Reserved	ADCTRIG	Reserved	READY	PWMEN
RESET	0	0	0	0	0	0	0	0
R/W	R/W	R/W	R/W	R/W	R/W	R/W	R/W	R/W
ADDR	F20H							

Bit Position	Value (H)	Description
[7] PWMOFF	0	Place PWM outputs in off-state Disable modulator control of PWM pins. Outputs are in predefined off-state. This is not dependent on the reload event.
	1	Re-enable modulator control of PWM pins at next PWM reload event.
[6] OUTCTL	0	PWM Output Control PWM outputs are controlled by the PWM.
	1	PWM outputs selectively disabled (set to off-state) according to values in the OUTx bits of the PWMOUT register.
[5] ALIGN	0	PWM Edge Alignment PWM outputs are edge aligned.
	1	PWM outputs are center aligned.
[4] Reserved		Reserved.
[3] ADCTRIG	0	ADC Trigger Enable No ADC trigger pulses.
	1	ADC trigger enabled.
[2] Reserved	0	Reserved.
[1] READY	0	Values Ready for Next Reload Event PWM values (pre-scale, period, and duty cycle) are not ready. Do not use values in holding registers at next PWM reload event.
	1	PWM values (pre-scale, period, and duty cycle) are ready. Transfer all values from temporary holding registers to working registers at next PWM reload event.
[0] PWMEN	0	PWM Enable PWM is disabled and enabled PWM output pins are forced to default off-state. PWM master counter is stopped. Certain control registers may only be written in this state.
	1	PWM is enabled and PWM output pins are enabled as outputs.

PWM Control 1 Register

The PWM Control 1 (PWMCTL1) register (Table 49) controls portions of PWM operation.

Table 49. PWM Control 1 Register (PWMCTL1)

BITS	7	6	5	4	3	2	1	0
FIELD	RLFREQ[1:0]		INDEN	Pol45	Pol23	Pol10	PRES[1:0]	
RESET	00		0	0	0	0	00	
R/W	R/W		R/W	R/W	R/W	R/W	R/W	
ADDR	F21H							

Bit Position	Value (H)	Description
[7:6] RLFREQ[1:0]		Reload Event Frequency This bit field is buffered. Changes to the reload event frequency takes effect at the end of the current PWM period. Reads always return the bit values from the temporary holding register.
	00	PWM reload event occurs at the end of every PWM period.
	01	PWM reload event occurs once every 2 PWM periods.
	10	PWM reload event occurs once every 4 PWM periods.
	11	PWM reload event occurs once every 8 PWM periods.
[5] INDEN	0	Independent PWM Mode Enable This bit may only be altered when <i>PWEN</i> (PWMCTL0) cleared. PWM outputs operate as 3 complementary pairs.
	1	PWM outputs operate as 6 independent channels.
[4] Pol2	1	Invert Output polarity for channel pair PWM2.
	0	Non-inverted polarity for channel pair PWM2.
[3] Pol1	1	Invert Output polarity for channel pair PWM1.
	0	Non-inverted polarity for channel pair PWM1.
[2] Pol0	1	Invert Output polarity for channel pair PWM0.
	0	Non-inverted polarity for channel pair PWM0.

Bit Position	Value (H)	Description
[1:0] PRES		PWM Prescaler The prescaler divides down the PWM input clock (either the system clock or the PWMIN external input). This field is buffered. Changes to this field take effect at the next PWM reload event. Reads always return the values from the temporary holding register.
	00	Divide by 1
	01	Divide by 2
	10	Divide by 4
	11	Divide by 8

PWM Deadband Register

The PWM Deadband (PWMDDB) register ([Table 50](#)) stores the 8-bit PWM deadband value. This register determines the number of system clock cycles inserted as dead-time in complementary output mode. The minimum deadband value is 1.

Table 50. PWM DeadBand Register (PWMDDB)

BITS	7	6	5	4	3	2	1	0
FIELD	PWMDDB[7:0]							
RESET	01H							
R/W	R/W							
ADDR	F22H							

Bit Position	Value (H)	Description
[7:0] PWMDDB		PWM Dead band Sets the PWM dead band period for which both PWM outputs of a complementary PWM output pair are deasserted.

Note: This register can only be written when `PWEN` is cleared.

PWM Minimum Pulse Width Filter

The value in the PWM Minimum Pulse Width Filter (PWMMPF) register ([Table 51](#)) determines the minimum width pulse, either High or Low, which can be generated by the PWM module. The minimum pulse width period is calculated as:

$$T_{\text{MINPULSEOUT}} = \frac{(\text{PWMDDB} + \text{PWMMPF}) * \text{PWMPrescale}}{\text{FOSC}}$$



Caution: *A Value other than 00H must be written to the PWMMPF register or the PWM output waveform will be distorted.*

Table 51. PWM Minimum Pulse Width Filter (PWMMPF)

BITS	7	6	5	4	3	2	1	0
FIELD	PWMMPF[7:0]							
RESET	00H							
R/W	R/W							
ADDR	F23H							

Bit Position	Value (H)	Description
[7:0]		PWM Minimum Pulse Filter
PWMMPF		Sets the minimum allowed output pulse width in PWM clock cycles.

Note: This register can only be written when `PWEN` is cleared.

PWM Fault Mask Register

The PWM Fault Mask (PWFMF) register (Table 52) enables individual fault sources. PWM behavior when an input is asserted is determined by the PWM Fault Control register (PWFMFCTL).

Table 52. PWM Fault Mask Register (PWFMF)

BITS	7	6	5	4	3	2	1	0
FIELD	Reserved		DBGMSK	Reserved		F1MASK	C0MASK	FMASK
RESET	00		0	000		0	0	0
R/W	R		R/W	R		R/W	R/W	R/W
ADDR	F24H							

Bit Position	Value (H)	Description
[7:6] Reserved		Must be 0.
[5] DBGMSK	0	Debug Entry Fault Mask Entering CPU DEBUG mode generates a PWM fault.
	1	Entering CPU DEBUG mode does not generate a PWM fault.
[4:3] Reserved		Must be 0.
[2] F1MASK	0	$\overline{\text{Fault1}}$ Fault Mask $\overline{\text{Fault1}}$ generates a PWM fault.
	1	$\overline{\text{Fault1}}$ does not generate a PWM fault.
[1] COMASK	0	Comparator Fault Mask Comparator generates a PWM fault.
	1	Comparator does not generate a PWM fault.
[0] F0MASK	0	Fault Pin Mask $\overline{\text{Fault0}}$ pin generates a PWM fault.
	1	$\overline{\text{Fault0}}$ pin does not generate a PWM fault.

Note: This register can only be written when `PWEN` is cleared.

PWM Fault Status Register

The PWM Fault Status (PWMFSTAT) register ([Table 53](#)) provides status of fault inputs and timer reload. The fault flags indicate which fault source is active. If a fault source is masked the flag in this register will not be set if the source is asserted. The reload flag is set when the timer compare values are updated. Clear flags by writing a 1 to the flag bits. Fault flag bits can only be cleared if the associated fault source has deasserted.

Table 53. PWM Fault Status Register (PWMFSTAT)

BITS	7	6	5	4	3	2	1	0
FIELD	RLDFlag	Reserved	DBGFLAG	Reserved		F1FLAG	C0FLAG	FFLAG
RESET	U	0	U	00		U	U	U
R/W	R/W1C	R	R/W1C	R		R/W1C	R/W1C	R/W1C
ADDR	F25H							

Bit Position	Value (H)	Description
[7] RLDFlag		Reload Flag This bit is set and latched when a PWM timer reload occurs. Writing a 1 to this bit clears the flag.
[6] Reserved	0	Reserved Always reads 0.
[5] DBGFLAG		Debug Flag This bit is set and latched when DEBUG mode is entered. Writing a 1 to this bit clears the flag.
[4:3] Reserved	0	Reserved Always reads 0.
[2] F1FLAG		Fault1 Flag This bit is set and latched when $\overline{\text{Fault1}}$ is asserted. Writing a 1 to this bit clears the flag.
[1] C0FLAG		Comparator 0 Flag This bit is set and latched when Comparator is asserted. Writing a 1 to this bit clears the flag.
[0] FFLAG		Fault Flag This bit is set and latched when the $\overline{\text{FAULT0}}$ input is asserted. Writing a 1 to this bit clears the flag.

Note: For this register, W1C means that you must write one to clear the flag.

PWM Fault Control Register

The PWM Fault Control (PWMFCTL) register (Table 54) determines how the PWM recovers from a fault condition. Settings in this register select automatic or software controlled PWM restart.

Table 54. PWM Fault Control Register (PWMFCTL)

BITS	7	6	5	4	3	2	1	0
FIELD	Reserved	DBGRST	Fault1INT	Fault1RST	CMP0INT	CMP0RST	Fault0INT	Fault0RST
RESET	0	0	0	0	0	0	0	0
R/W	R/W	R/W	R/W	R/W	R/W	R/W	R/W	R/W
ADDR	F28H							

Bit Position	Value (H)	Description
[7] Reserved	0	Reserved.
[6] DBGRST	0	DebugRestart Automatic recovery. PWM resumes control of outputs when all fault sources have deasserted and a new PWM period begins.
	1	Software controlled recovery. PWM resumes control of outputs only after all fault sources have deasserted and all fault flags are cleared and a PWM reload occurs.
[5] Fault1INT	0	<u>Fault1</u> Interrupt Interrupt on comparator assertion disabled.
	1	Interrupt on comparator assertion enabled.
[4] Fault1RST	0	<u>Fault1</u> Restart Automatic recovery. PWM resumes control of outputs when all fault sources have deasserted.
	1	Software controlled recovery. PWM resumes control of outputs only after all fault sources have deasserted and all fault flags are cleared and a PWM reload occurs.
[3] CMP0INT	0	Comparator 0 Interrupt Interrupt on comparator 0 assertion disabled.
	1	Interrupt on comparator 0 assertion enabled.

Bit Position	Value (H)	Description
[2] CMPORST	0	Comparator 0 Restart Automatic recovery. PWM resumes control of outputs when all fault sources have deasserted.
	1	Software controlled recovery. PWM resumes control of outputs only after all fault sources have deasserted and all fault flags are cleared and a PWM reload occurs
[1] Fault0INT	0	<u>Fault0</u> Interrupt Interrupt on <u>Fault0</u> pin assertion disabled.
	1	Interrupt on <u>Fault0</u> pin assertion enabled.
[0] Fault0RST	0	<u>Fault0</u> Restart Automatic recovery. PWM resumes control of outputs when all fault sources have deasserted.
	1	Software controlled recovery. PWM resumes control of outputs only after all fault sources have deasserted and all fault flags are cleared and a PWM reload occurs

Note: This register can only be written when PWEN is cleared.

PWM Input Sample Register

PWM pin values are sampled by reading the PWM Input Sample register (Table 55).

Table 55. PWM Input Sample Register (PWWIN)

BITS	7	6	5	4	3	2	1	0
FIELD	Reserved	FAULT	IN2H	IN2L	IN1H	IN1L	IN0H	IN0L
RESET	0	0	0	0	0	0	0	0
R/W	R	R/W	R/W	R/W	R/W	R/W	R/W	R/W
ADDR	F26H							

Bit Position	Value (H)	Description
[7] Reserved		Must be 0.
[6] FAULT	0	Sample <u>Fault0</u> pin A Low level signal was read on the <u>Fault0</u> pin.
	1	A High level signal was read on the <u>Fault0</u> pin.

Bit Position	Value (H)	Description
[5:0] IN2H/IN2L/ IN1H/IN1L/ IN0H/IN0L	0	Sample PWM pins A Low level signal was read on the pins.
	1	A High level signal was read on the pins.

PWM Output Control Register

The PWM Output Control (PWMOUT) register (Table 56) enables modulator control of the six PWM output signals. Output control is enabled by OUTCTL bit in the PWMCTL0 register. The PWM continues to operate, but has no effect on the disabled PWM pins. If a fault condition is detected, all PWM outputs are forced to their selected OFF state.

Table 56. PWM Output Control Register (PWMOUT)

BITS	7	6	5	4	3	2	1	0
FIELD	Reserved	Reserved	OUT2L	OUT2H	OUT1L	OUT1H	OUT0L	OUT0H
RESET	0	0	0	0	0	0	0	0
R/W	R	R	R/W	R/W	R/W	R/W	R/W	R/W
ADDR	F27H							

Bit Position	Value (H)	Description
[7,6] Reserved		Must be 0.
[5, 3, 1] OUT2L/ OUT1L/ OUT0L	0	PWM L2/L1/L0 Output Configuration PWM L2/L1/L0 output signal is enabled and controlled by PWM.
	1	PWM L2/L1/L0 output signal is in low-side off-state.
[4, 2, 0] OUT2H/ OUT1H/ OUT0H	0	PWM H2/H1/H0 Output Configuration PWM H2/H1/H0 output signal is enabled and controlled by PWM.
	1	PWM H2/H1/H0 output signal is in high-side off-state.

Current Sense ADC Trigger Control Register

An ADC trigger is generated when the PWM output signals match the state specified by the Current-Sense ADC-Trigger control register. The match logic is an AND-OR tree that

will solve to true if based on the register settings. An ADC conversion will be triggered on the rising edge of this signal.

The logic equation for the adc-trigger is:

$$\text{ADCTRIGGER} = \text{CSTPOL} \wedge (\\ \text{(HEN \& PWMH0 \& PWMH1 \& PWMH2) |} \\ \text{(LEN \& PWML0 \& PWML1 \& PWML2) |} \\ \text{(nHEN \& !PWMH0 \& !PWMH1 \& !PWMH2) |} \\ \text{(nLEN \& !PWMH0 \& !PWMH1 \& !PWMH2))}$$

where

- the ^ symbol indicates a logical exclusive OR (XOR) function
- the & symbol indicates a logical AND function
- the | symbol indicates a logical OR function
- the ! symbol indicates a logical NOT function

The combinations of polarity, enable, and PWM signals allow the logic to generate an ADC-trigger under a wide variety of operating conditions. The HEN, LEN, nHEN, and nLEN bits enable a group in the OR logic. The CSTPWMx bits allow the level of the PWM output signals to control the equation. If a CSTPWMx bit is cleared, the value of the associated PWMx output always evaluates to a TRUE condition in the equation. Note that these bits do not affect the actual PWM outputs.

Table 57. Current-Sense Trigger Control Register (PWMSHC)

BITS	7	6	5	4	3	2	1	0
FIELD	CSTPOL	HEN	NHEN	LEN	NLEN	CSTPWM2	CSTPWM1	CSTPWM0
RESET	0	0	0	0	0	0	0	0
R/W	R/W	R/W	R/W	R/W	R/W	R/W	R/W	R/W
ADDR	F29H							

Bit Position	Value (H)	Description
[7] CSTPOL	0	Sample Hold Polarity Hold when terms are active
	1	Hold when terms are not active
[6] HEN	0	High Side Active enable Ignore Product of PWMH0, PWMH1, and PWMH2 in Sample/Hold equation
	1	Hold when PWMH0, PWMH1, and PWMH2 are all active.
[5] NHEN	0	High Side inactive <u>enable</u> Ignore Product of PWMH0, <u>PWMH1</u> , and <u>PWMH2</u> in Sample/Hold equation
	1	Hold when are all active
[4] LEN	0	Low Side Active enable Ignore Product of PWML0, PWML1, and PWML2 in Sample/Hold equation
	1	Hold when PWML0, PWML1, and PWML2 are all active
[3] NLEN	0	Low Side Inactive <u>enable</u> Ignore Product of <u>PWML0</u> , <u>PWML1</u> , and <u>PWML2</u> in Sample/Hold equation
	1	Hold when <u>PWML0</u> , <u>PWML1</u> , and <u>PWML2</u> are all active
[2] CSTPWM2	0	PWM Channel2 Sample/Hold Enable Channel 2 terms are not used in Sample/Hold Equation
	1	Channel 2 terms are used in Sample/Hold Equation
[1] CSTPWM1	0	PWM Channel1 Sample/Hold Enable Channel 1 terms are not used in Sample/Hold Equation
	1	Channel 1 terms are used in Sample/Hold Equation
[0] CSTPWM0	0	PWM Channel0 Sample/Hold Enable Channel 0 terms are not used in Sample/Hold Equation
	1	Channel 0 terms are used in Sample/Hold Equation

General-Purpose Timer

The Z8FMC16100 Series Flash MCU contains one 16-bit reloadable timer used for timing, event counting, or generation of PWM signals.

Features

The features of general-purpose timer include:

- 16-bit reload counter
- Programmable prescaler with prescale values from 1 to 128
- PWM output generation (single or differential)
- Capture and compare capability
- External input pin for event counting, clock gating, or capture signal
- Complementary Timer Output pins
- Timer interrupt

Architecture

Capture and compare capability measures the velocity from a tachometer wheel or reads sensor outputs for rotor position for brushless DC motor commutation. [Figure 10](#) displays the architecture of the timer.

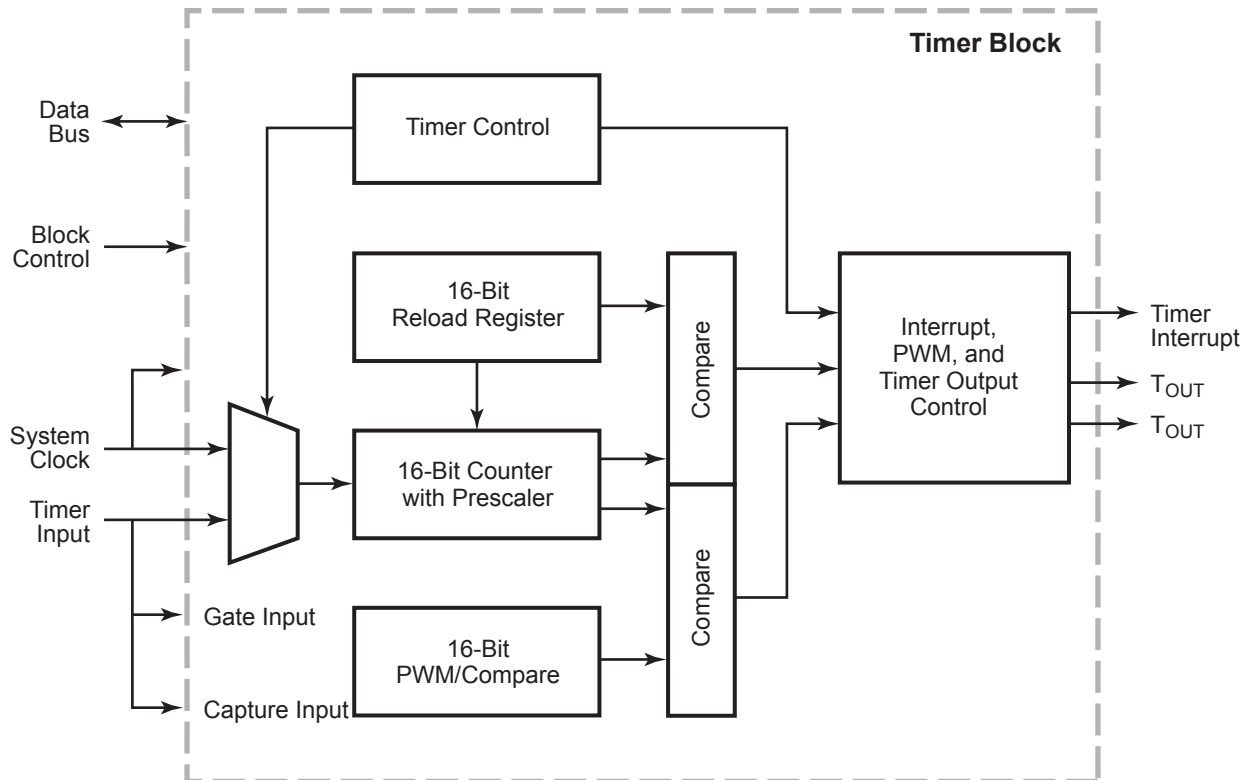

Figure 10. Timer Block Diagram

Operation

The general-purpose timer is a 16-bit up-counter. In normal operation, the timer is initialized to 0001h. After it is enabled, the timer counts up to the value contained in the Reload High and Low Byte registers, then resets to 0001h. The counter either halts or continues, depending on its current mode of operation.

Minimum timeout delay (**1 system clock in duration**) is set by loading the value 0001h into the Timer Reload High and Low Byte registers and setting the prescale value to 1.

Maximum timeout delay (**$2^{16} \times 2^7$ system clocks**) is set by loading the value 0000h into the Timer Reload High and Low Byte registers and setting the prescale value to 128. When the timer reaches FFFFh, the timer rolls over to 0000h.

If the reload register is set to a value less than the current counter value, the counter continues counting until reaching FFFFh, rolls over to 0000h, and continues counting until reaching the reload value, then resets to 0001h.

Timer Operating Modes

The timers can be configured to operate in the following eleven modes:

- ONE-SHOT mode
- TRIGGERED ONE-SHOT mode
- CONTINUOUS mode
- COUNTER mode
- COMPARATOR COUNTER mode
- PWM SINGLE OUTPUT mode
- PWM DUAL OUTPUT mode
- CAPTURE RESTART mode
- CAPTURE COMPARE mode
- COMPARE mode
- GATED mode

ONE-SHOT Mode

In ONE-SHOT mode, the timer counts up to the 16-bit reload value stored in the Timer Reload High and Low Byte registers. The Timer Input is the system clock. After reaching this reload value, the timer generates an interrupt and the count value in the Timer High and Low Byte registers is reset to 0001h. The timer is automatically disabled and stops counting.

If the Timer Output alternate function is enabled, the Timer Output pin changes state for one system clock cycle (from Low to High, then back to Low if $TPOL = 0$) at timer reload. If the user chooses, the Timer Output can undergo a permanent state change upon One-Shot timeout, as given below:

1. Set the $TPOL$ bit in the Timer Control 1 register to the start value before beginning ONE-SHOT mode.
2. After starting the timer, set $TPOL$ to the opposite value.

Follow the steps below to configure a timer for ONE-SHOT mode and initiate the count:

1. Write to the Timer Control registers to:
 - (a) Disable the timer.
 - (b) Configure the timer for ONE-SHOT mode.
 - (c) Set the prescale value.

- (d) If using the Timer Output alternate function, set the initial output level (High or Low) using the TPOL bit.
- (e) Set the interrupt mode.
- 2. Write to the Timer High and Low Byte registers to set the starting count value.
- 3. Write to the Timer Reload High and Low Byte registers to set the reload value.
- 4. If appropriate, enable the timer interrupt and set the timer interrupt priority by writing to the relevant interrupt registers.
- 5. If using the Timer Output function, configure the associated GPIO port pin for the Timer Output alternate function.
- 6. Write to the Timer Control 1 register to enable the timer and initiate counting.

The timer period is calculated by the following equation (Start Value = 1):

$$\text{ONE-SHOT Mode Timeout Period (s)} = \frac{(\text{Reload Value} - \text{Start Value} + 1) \times \text{Prescaler}}{\text{System Clock Frequency (Hz)}}$$

TRIGGERED ONE-SHOT Mode

In TRIGGERED ONE-SHOT mode, the timer operates as given below:

1. The Timer idles until a trigger is received. The timer trigger is taken from the Timer Input pin. The TPOL bit in the Timer Control 1 register selects whether the trigger occurs on the rising edge or the falling edge of the Timer Input signal.
2. Following the trigger event, the timer counts system clocks up to the 16-bit reload value stored in the Timer Reload High and Low Byte registers.
3. Upon reaching the reload value, the timer outputs a pulse on the Timer Output pin, generates an interrupt, and resets the count value in the Timer High and Low Byte registers to 0001h. The duration of the output pulse is a single system clock. The TPOL bit also sets the polarity of the output pulse.
4. The timer idles until the next trigger event. Trigger events that occur while the timer is responding to a previous trigger is ignored.

Follow the steps below to configure Timer 0 in TRIGGERED ONE-SHOT mode and initiate operation:

1. Write to the Timer Control registers to:
 - (a) Disable the timer.
 - (b) Configure the timer for TRIGGERED ONE-SHOT mode.
 - (c) Set the prescale value.

- (d) If using the Timer Output alternate function, set the initial output level (High or Low) via the TPOL bit.
- (e) Set the INTERRUPT mode.
- 2. Write to the Timer High and Low Byte registers to set the starting count value.
- 3. Write to the Timer Reload High and Low Byte registers to set the reload value.
- 4. If appropriate, enable the timer interrupt and set the timer interrupt priority by writing to the relevant interrupt registers.
- 5. If using the Timer Output function, configure the associated GPIO port pin for the Timer Output alternate function.
- 6. Write to the Timer Control 1 register to enable the timer. Counting does not start until the appropriate input transition occurs.

The timer period is calculated by the following equation (Start Value = 1):

$$\text{TRIGGERED ONE-SHOT Mode Timeout Period (s)} = \frac{(\text{Reload Value} - \text{Start Value} + 1) \times \text{Prescaler}}{\text{System Clock Frequency (Hz)}}$$

► **Note:** *The one-shot delay from input trigger to output includes the above-defined timeout period, plus an additional delay of 2–3 system clock cycles, due to the synchronization of the input trigger.*

CONTINUOUS Mode

In CONTINUOUS mode, the timer counts up to the 16-bit reload value stored in the Timer Reload High and Low Byte registers. After reaching the reload value, the timer generates an interrupt, the count value in the Timer High and Low Byte registers is reset to 0001h, and counting resumes. Also, if the Timer Output alternate function is enabled, the Timer Output pin changes state (from Low to High or High to Low) after timer reload.

Follow the steps below to configure a timer for CONTINUOUS mode and initiate the count:

1. Write to the Timer Control registers to:
 - (a) Disable the timer.
 - (b) Configure the timer for CONTINUOUS mode.
 - (c) Set the prescale value.
 - (d) If using the Timer Output alternate function, set the initial output level (High or Low) through TPOL.

2. Write to the Timer High and Low Byte registers to set the starting count value (usually 0001h). This setting only affects the first pass in CONTINUOUS mode. After the first timer reloads in CONTINUOUS mode, counting begins at the reset value of 0001h.
3. Write to the Timer Reload High and Low Byte registers to set the reload period.
4. If appropriate, enable the timer interrupt and set the timer interrupt priority by writing to the relevant interrupt registers.
5. If using the Timer Output function, configure the associated GPIO port pin for the Timer Output alternate function.
6. Write to the Timer Control 1 register to enable the timer and initiate counting.

The timer period is calculated by the following equation:

$$\text{CONTINUOUS Mode Timeout Period (s)} = \frac{\text{Reload Value} \times \text{Prescaler}}{\text{System Clock Frequency (Hz)}}$$

If an initial starting value other than 0001h is loaded into the Timer High and Low Byte registers, use the ONE-SHOT mode equation to determine the first timeout period.

COUNTER and COMPARATOR COUNTER Modes

In COUNTER mode, the timer counts input transitions from a GPIO port pin. The Timer Input is taken from the associated GPIO port pin. The TPOL bit in the Timer Control 1 register selects whether the count occurs on the rising edge or the falling edge of the Timer Input signal. In COUNTER mode, the prescaler is disabled.



Caution: *The input frequency of the Timer Input signal must not exceed one-fourth the system clock frequency.*

In COMPARATOR COUNTER mode, the timer counts output transitions from an analog comparator output. Timer 0 takes its input from the output of the comparator. The TPOL bit in the Timer Control 1 register selects whether the count occurs on the rising edge or the falling edge of the comparator output signal. In COMPARATOR COUNTER mode, the prescaler is disabled.



Caution: *The frequency of the comparator output signal must not exceed one-fourth the system clock frequency.*

After reaching the reload value stored in the Timer Reload High and Low Byte registers, the timer generates an interrupt, the count value in the Timer High and Low Byte registers is reset to 0001h, and counting resumes.

If the Timer Output alternate function is enabled, the Timer Output pin changes state (from Low to High or High to Low) at timer reload.

Follow the steps below to configure a timer for COUNTER and COMPARATOR COUNTER modes and initiate the count:

1. Write to the Timer Control registers to:
 - (a) Disable the timer.
 - (b) Configure the timer for COUNTER or COMPARATOR COUNTER mode.
 - (c) Select either the rising edge or falling edge of the Timer Input or comparator output signal for the count. This choice also sets the initial logic level (High or Low) for the Timer Output alternate function. However, the Timer Output function does not have to be enabled.
2. Write to the Timer High and Low Byte registers to set the starting count value. This setting only affects the first pass in the counter modes. After the first timer reload, counting begins at the reset value of 0001h.
3. Write to the Timer Reload High and Low Byte registers to set the reload value.
4. If appropriate, enable the timer interrupt and set the timer interrupt priority by writing to the relevant interrupt registers.
5. Configure the associated GPIO port pin for the Timer Input alternate function (COUNTER mode).
6. If using the Timer Output function, configure the associated GPIO port pin for the Timer Output alternate function.
7. Write to the Timer Control 1 register to enable the timer.

PWM SINGLE and DUAL OUTPUT Modes

In PWM SINGLE OUTPUT mode, the timer outputs a PWM output signal through a GPIO port pin. In PWM DUAL OUTPUT mode, the timer outputs a PWM output signal and also its complement through two GPIO port pins. The timer first counts up to the 16-bit PWM match value stored in the Timer PWM High and Low Byte registers. When the timer count value matches the PWM value, the Timer Output toggles. The timer continues counting until it reaches the reload value stored in the Timer Reload High and Low Byte registers. On reaching the reload value, the timer generates an interrupt, the count value in the Timer High and Low Byte registers is reset to 0001h, and counting resumes.

The Timer Output signal begins with a value equal to T_{POL} and then transits to $\overline{T_{POL}}$ when the timer value matches the PWM value. The Timer Output signal returns to T_{POL} after the timer reaches the reload value and is reset to 0001h.

In PWM DUAL OUTPUT mode, the timer also generates a second PWM output signal, Timer Output Complement ($\overline{T_{OUT}}$). A programmable deadband can be configured (PWMD field) to delay (0–128 system clock cycles) the Low to a High (inactive to active) output transitions on these two pins. This configuration ensures a time gap between the deassertion of one PWM output to the assertion of its complement.

Follow the steps below to configure a timer for either PWM SINGLE or DUAL OUTPUT mode and initiate PWM operation:

1. Write to the Timer Control registers to:
 - (a) Disable the timer.
 - (b) Configure the timer for the selected PWM mode.
 - (c) Set the prescale value.
 - (d) Set the initial logic level (High or Low) and PWM High/Low transition for the Timer Output alternate function with the TPOL bit.
 - (e) Set the deadband delay (DUAL OUTPUT mode) with the PWMD field.
2. Write to the Timer High and Low Byte registers to set the starting count value (typically 0001h). The starting count value only affects the first pass in PWM mode. After the first timer reset in PWM mode, counting begins at the reset value of 0001h.
3. Write to the PWM High and Low Byte registers to set the PWM value.
4. Write to the Timer Reload High and Low Byte registers to set the reload value (PWM period). The reload value must be greater than the PWM value.
5. If appropriate, enable the timer interrupt and set the timer interrupt priority by writing to the relevant interrupt registers.
6. Configure the associated GPIO port pin(s) for the Timer Output alternate function.
7. Write to the Timer Control 1 register to enable the timer and initiate counting.

The PWM period is determined by the following equation:

$$\text{PWM Period (s)} = \frac{\text{Reload Value} \times \text{Prescaler}}{\text{System Clock Frequency (Hz)}}$$

If an initial starting value other than 0001h is loaded into the Timer High and Low Byte registers, use the ONE-SHOT mode equation to determine the first PWM timeout period.

If TPOL is set to 0, the ratio of the PWM output High time to the total period is determined by the equation:

$$\text{PWM Output High Time Ratio (\%)} = \frac{\text{Reload Value} - \text{PWM Value}}{\text{Reload Value}} \times 100$$

If T_{POL} is set to 1, the ratio of the PWM output High time to the total period is determined by the equation:

$$\text{PWM Output High Time Ratio (\%)} = \frac{\text{PWM Value}}{\text{Reload Value}} \times 100$$

CAPTURE Modes

There are three capture modes that provide slightly different methods for recording the time or time interval between, Timer Input events. These modes are CAPTURE mode, CAPTURE RESTART mode, and CAPTURE COMPARE mode. In all three modes, when the appropriate Timer Input transition (capture event) occurs, the timer counter value is captured and stored in the PWM High and Low Byte registers. The T_{POL} bit in the Timer Control 1 register determines whether the Capture occurs on a rising edge or a falling edge of the Timer Input signal. The $TICONFIG$ bit determines whether interrupts are generated on capture events, reload events, or both. The $INCAP$ bit in Timer Control 0 register clears to indicate an interrupt caused by a reload event and sets to indicate the timer interrupt is caused by an input capture event.

There is a delay from the input event to the timer capture of 2–3 system clock cycles, due to internal synchronization logic.

If the Timer Output alternate function is enabled, the Timer Output pin changes state (from Low to High or High to Low) at timer reload. The initial value is determined by the T_{POL} bit.

CAPTURE Mode—In CAPTURE mode, and after it is enabled, the timer counts continuously and rolls over from $FFFFh$ to $0000h$. When the capture event occurs, the timer counter value is captured and stored in the PWM High and Low Byte registers, an interrupt is generated, and the timer continues counting. The timer continues counting up to the 16-bit reload value stored in the Timer Reload High and Low Byte registers. Upon reaching the reload value, the timer generates an interrupt and continues counting.

CAPTURE RESTART Mode—In CAPTURE RESTART mode, after it is enabled, the timer counts continuously until the capture event occurs or the timer count reaches the 16-bit compare value stored in the Timer Reload High and Low Byte registers. If the capture event occurs first, the timer counter value is captured and stored in the PWM High and Low Byte registers. An interrupt is generated, the count value in the Timer High and Low Byte registers is reset to $0001h$, and counting resumes. If no capture event occurs, upon reaching the reload value, the timer generates an interrupt, the count value in the Timer High and Low Byte registers is reset to $0001h$, and counting resumes.

CAPTURE/COMPARE Mode—CAPTURE/COMPARE mode is identical to CAPTURE RESTART mode, except that counting does not start until the first external Timer Input transition occurs. Every subsequent transition (after the first) of the Timer Input signal captures the current count value. When the capture event occurs, an interrupt is generated,

the count value in the Timer High and Low Byte registers is reset to 0001h, and counting resumes. If no capture event occurs, upon reaching the compare value, the timer generates an interrupt, the count value in the Timer High and Low Byte registers is reset to 0001h, and counting resumes.

Follow the steps below to configure a timer for one of these capture modes and initiate the count:

1. Write to the Timer Control registers to:
 - (a) Disable the timer.
 - (b) Configure the timer for the selected capture mode.
 - (c) Set the prescale value.
 - (d) Set the capture edge (rising or falling) for the Timer Input.
 - (e) Configure the timer interrupt to be generated at the input capture event, the reload event, or both, by setting the `TICONFIG` field.
2. Write to the Timer High and Low Byte registers to set the starting count value (typically 0001h).
3. Write to the Timer Reload High and Low Byte registers to set the reload value.
4. If appropriate, enable the timer interrupt and set the timer interrupt priority by writing to the relevant interrupt registers.
5. Configure the associated GPIO port pin for the Timer Input alternate function.
6. Write to the Timer Control 1 register to enable the timer. In `CAPTURE` and `CAPTURE RESTART` modes, the timer begins counting. In `CAPTURE COMPARE` mode, the timer does not start counting until the first input transition occurs.

In capture modes, the elapsed time from a timer start to a capture event can be calculated using the following equation (Start Value = 1):

$$\text{Capture Elapsed Time (s)} = \frac{(\text{Capture Value} - \text{Start Value} + 1) \times \text{Prescale}}{\text{System Clock Frequency (Hz)}}$$

COMPARE Mode

In `COMPARE` mode, the timer counts up to the 16-bit compare value stored in the Timer Reload High and Low Byte registers. After reaching the compare value, the timer generates an interrupt and counting continues (the timer value is not reset to 0001h). If the Timer Output alternate function is enabled, the Timer Output pin changes state (from Low to High or High to Low).

If the timer reaches `FFFFh`, the timer rolls over to `0000h` and continues counting.

Follow the steps below to configure a timer for COMPARE mode and initiate the count:

1. Write to the Timer Control registers to:
 - (a) Disable the timer.
 - (b) Configure the timer for COMPARE mode.
 - (c) Set the prescale value.
 - (d) Set the initial logic level (High or Low) for the Timer Output alternate function, if appropriate.
2. Write to the Timer High and Low Byte registers to set the starting count value.
3. Write to the Timer Reload High and Low Byte registers to set the Compare value.
4. If appropriate, enable the timer interrupt and set the timer interrupt priority by writing to the relevant interrupt registers.
5. If using the Timer Output function, configure the associated GPIO port pin for the Timer Output alternate function.
6. Write to the Timer Control 1 register to enable the timer and initiate counting.

The compare time is calculated by the following equation (Start Value = 1):

$$\text{Compare Mode Time (s)} = \frac{(\text{Compare Value} - \text{Start Value} + 1) \times \text{Prescale}}{\text{System Clock Frequency (Hz)}}$$

GATED Mode

In GATED mode, the timer counts only when the Timer Input signal is in its active state, as determined by the TPOL bit in the Timer Control 1 register. When the Timer Input signal is active, counting begins. A timer interrupt is generated when the Timer Input signal transits from active to inactive state, a timer reload occurs, or both, depending on TICONFIG[1:0]. To determine if a Timer Input signal deassertion generated the interrupt, read the associated GPIO input value and compare it to the value stored in the TPOL bit.

The timer counts up to the 16-bit reload value stored in the Timer Reload High and Low Byte registers. On reaching the reload value, the timer generates an interrupt, the count value in the Timer High and Low Byte registers is reset to 0001h, and counting continues as long as the Timer Input signal is active. Also, if the Timer Output alternate function is enabled, the Timer Output pin changes state (from Low to High or from High to Low) at timer reload.

Follow the steps below for configuring a timer for GATED mode and initiating the count:

1. Write to the Timer Control registers to:
 - (a) Disable the timer.
 - (b) Configure the timer for GATED mode.
 - (c) Set the prescale value.
 - (d) Select the active state of the Timer Input through the TPOL bit.
2. Write to the Timer High and Low Byte registers to set the starting count value. This setting only affects the first pass in GATED mode. After the first timer reset in GATED mode, counting begins at the reset value of 0001h.
3. Write to the Timer Reload High and Low Byte registers to set the reload value.
4. If appropriate, enable the timer interrupt and set the timer interrupt priority by writing to the relevant interrupt registers.
5. Configure the timer interrupt to be generated only at the input deassertion event, the reload event, or both, by setting the TICONFIG field of the Timer Control 0 register.
6. Configure the associated GPIO port pin for the Timer Input alternate function.
7. Write to the Timer Control 1 register to enable the timer.
8. The timer counts when the Timer Input is equal to the TPOL bit.

Reading the Timer Count Values

The current count value in the timers can be read while counting (enabled). This Read has no effect on timer operation. When the timer is enabled and the Timer High Byte register is read, the contents of the Timer Low Byte register are placed into a holding register. A subsequent Read from Timer Low Byte register returns the value in the holding register. This operation allows accurate Reads of the full 16-bit timer count value while enabled. When the timer is not enabled, a Read from the Timer Low Byte register returns the actual value in the counter.

Timer 0 High and Low Byte Registers

The Timer 0 High and Low Byte (T0H and T0L) registers ([Table 53](#) and [Table 59](#)) contain the current 16-bit timer count value. When the timer is enabled, a Read from T0H causes the value in T0L to be stored in a temporary holding register. A Read from T0L always returns this temporary register when the timer is enabled. When the timer is disabled, Reads from the T0L are direct from this temporary register.



Caution: *Writing to the Timer High and Low Byte registers while the timer is enabled is not recommended. There are no temporary holding registers available for Write operations; therefore, simultaneous 16-bit Writes are not possible.*

If either the Timer High or Low Byte registers are written during counting, the 8-bit written value is placed in the counter (High or Low Byte) at the next clock edge. The counter continues counting from the new value.

Table 58. Timer 0 High Byte Register (T0H)

BITS	7	6	5	4	3	2	1	0
FIELD	TH							
RESET	00H							
R/W	R/W							
ADDR	F00H							

Table 59. Timer 0 Low Byte Register (T0L)

BITS	7	6	5	4	3	2	1	0
FIELD	TL							
RESET	01H							
R/W	R/W							
ADDR	F01H							

TH and TL—Timer High and Low Bytes

These two bytes, {TH[7:0], TL[7:0]}, contain the current 16-bit timer count value.

Timer 0 Reload High and Low Byte Registers

The Timer 0 Reload High and Low Byte (T0RH and T0RL) registers (Table 60 and Table 61) store a 16-bit reload value, {TRH[7:0], TRL[7:0]}. Values written to the Timer Reload High Byte register are stored in a temporary holding register. When a Write to the Timer Reload Low Byte register occurs, the temporary holding register value is written to the Timer High Byte register. This operation allows simultaneous updates of the 16-bit timer reload value.

Table 60. Timer 0 Reload High Byte Register (T0RH)

BITS	7	6	5	4	3	2	1	0
FIELD	TRH							
RESET	FFH							
R/W	R/W							
ADDR	F02H							

Table 61. Timer 0 Reload Low Byte Register (T0RL)

BITS	7	6	5	4	3	2	1	0
FIELD	TRL							
RESET	FF							
R/W	R/W							
ADDR	F03H							

TRH and TRL—Timer Reload Register High and Low

These two bytes form the 16-bit Reload value, {TRH[7:0], TRL[7:0]}. This value sets the maximum count value which initiates a timer reload to 0001H.

Timer 0 PWM High and Low Byte Registers

The Timer 0 PWM High and Low Byte (T0PWMH and T0PWML) registers, shown in Table 62 63, define PWM operations. These registers also store the timer counter values for the Capture modes.

The two bytes {PWMH[7:0], PWML[7:0]} form a 16-bit value that is compared to the current 16-bit timer count. When a match occurs, the PWM output changes state. The PWM output value is set by the TPOL bit in the Timer Control 1 register (T0CTL1).

The T0PWMH and T0PWML registers also store the 16-bit captured timer value when operating in CAPTURE or CAPTURE/COMPARE modes.

Table 62. Timer 0 PWM High Byte Register (T0PWMH)

BITS	7	6	5	4	3	2	1	0
FIELD	PWMH							
RESET	00H							
R/W	R/W							
ADDR	F04H							

Table 63. Timer 0 PWM Low Byte Register (T0PWML)

BITS	7	6	5	4	3	2	1	0
FIELD	PWML							
RESET	00H							
R/W	R/W							
ADDR	F05H							

PWMH and PWML—PWM High and Low Bytes

These two bytes, {PWMH[7:0], PWML[7:0]}, form a 16-bit value which is compared to the current 16-bit timer count. When a match occurs, the PWM output changes state. The PWM output value is set by the TPOL bit in the Timer Control 1 register (T0CTL1).

The T0PWMH and T0PWML registers also store the 16-bit captured timer value when operating in CAPTURE or CAPTURE/COMPARE modes.

Timer 0 Control Registers

Two Timer 0 control registers determine timer configuration (T0CTL0) and operation (T0CTL1).

Timer 0 Control 0 Register

The Timer 0 Control 0 (T0CTL0) register together with the Timer 0 Control 1 (T0CTL1) register, determines the timer configuration and operation. See [Table 64](#).

Table 64. Timer 0 Control 0 Register (T0CTL0)

BITS	7	6	5	4	3	2	1	0
FIELD	TMODE[3]	TICONFIG		TINSEL	PWMD		INCAP	
RESET	0	00		0	000		0	
R/W	R/W	R/W		R/W	R/W		R	
ADDR	F06H							

Bit Position	Value (H)	Description
[7] TMODE[3]		<p>Timer Mode High Bit This bit along with TMODE[2:0] field in T0CTL1 register determines the operating mode of the timer. This is the most significant bit of the Timer mode selection value. For more details, see the T0CTL1 register description.</p>
[6–5] TICONFIG		<p>Timer Interrupt Configuration—This field configures timer interrupt definitions. These bits affect all modes. The effect per mode is explained below:</p> <p>ONE SHOT, CONTINUOUS, COUNTER, PWM, COMPARE, DUAL PWM, TRIGGERED ONE-SHOT, COMPARATOR COUNTER: 0x Timer interrupt occurs on reload. 10 Timer interrupts are disabled. 11 Timer Interrupt occurs on reload.</p> <p>GATED: 0x Timer interrupt occurs on reload or inactive gate edge. 10 Timer interrupt occurs on inactive gate edge. 11 Timer interrupt occurs on reload.</p> <p>CAPTURE, CAPTURE/COMPARE, CAPTURE RESTART: 0x Timer interrupt occurs on reload and capture. 10 Timer interrupt occurs on capture only. 11 Timer interrupt occurs on reload only</p>

Bit Position	Value (H)	Description
[4] TINSEL	0 1	Timer Input Select Timer input is the Timer input pin. Timer input is the comparator output.
[3–1] PWMD	000 001 010 011 100 101 110 111	PWM Delay Value This field is a programmable delay to control the number of additional system clock cycles following a PWM or Reload compare before the Timer Output or the Timer Output Complement is switched to the active state. This field ensures a time gap between the deassertion of one PWM output to the assertion of its complement. No delay 2 cycles delay 4 cycles delay 8 cycles delay 16 cycles delay 32 cycles delay 64 cycles delay 128 cycles delay
[0] INCAP	0 1	Input Capture Event Previous timer interrupt is not a result of a Timer Input Capture Event Previous timer interrupt is a result of a Timer Input Capture Event.

Timer 0 Control 1 Register

The Timer 0 Control 1 (T0CTL1) register (Table 65) enables/disables the timer, sets the prescaler value, and determines the timer operating mode.

Table 65. Timer 0 Control 1 Register (T0CTL1)

BITS	7	6	5	4	3	2	1	0
FIELD	TEN	TPOL	PRES			TMODE		
RESET	0	0	000			000		
R/W	R/W	R/W	R/W			R/W		
ADDR	F07H							

Bit Position	Value (H)	Description
[7] TEN	0 1	Timer is enabled. Timer is disabled. Timer is enabled.

Bit Position	Value (H)	Description
[6] TPOL		<p>Timer Input/Output Polarity This bit is a function of the current operating mode of the timer. It determines the polarity of the input and/or output signal. When the timer is disabled, the Timer Output signal is set to the value of this bit.</p> <p>ONE-SHOT mode—If the timer is enabled the Timer Output signal pulses (changes state) for one system clock cycle after timer Reload.</p> <p>CONTINUOUS mode—If the timer is enabled the Timer Output signal is complemented after timer Reload.</p> <p>COUNTER mode—If the timer is enabled the Timer Output signal is complemented after timer reload. 0 = Count occurs on the rising edge of the Timer Input signal. 1 = Count occurs on the falling edge of the Timer Input signal.</p> <p>PWM SINGLE OUTPUT mode—When enabled, the Timer Output is forced to $\overline{\text{TPOL}}$ after PWM count match and forced back to TPOL after Reload.</p> <p>CAPTURE mode—If the timer is enabled, the Timer Output signal is complemented after timer Reload. 0 = Count is captured on the rising edge of the Timer Input signal. 1 = Count is captured on the falling edge of the Timer Input signal.</p> <p>COMPARE mode—The Timer Output signal is complemented after timer Reload.</p> <p>GATED mode—The Timer Output signal is complemented after timer Reload. 0 = Timer counts when the Timer Input signal is High and interrupts are generated on the falling edge of the Timer Input. 1 = Timer counts when the Timer Input signal is Low and interrupts are generated on the rising edge of the Timer Input.</p> <p>CAPTURE/COMPARE mode—If the timer is enabled, the Timer Output signal is complemented after timer Reload 0 = Counting starts on the first rising edge of the Timer Input signal. The current count is captured on subsequent rising edges of the Timer Input signal. 1 = Counting starts on the first falling edge of the Timer Input signal. The current count is captured on subsequent falling edges of the Timer Input signal.</p>

Bit Position	Value (H)	Description
		<p>PWM DUAL OUTPUT mode—If enabled, the Timer Output is set=T_{POL} after PWM match and set=T_{POL} after Reload. If enabled the Timer Output Complement takes on the opposite value of the Timer Output. The PWMD field in the T0CTL1 register determines an optional added delay on the assertion (Low to High) transition of both Timer Output and the Timer Output Complement for deadband generation.</p> <p>CAPTURE RESTART mode—If the timer is enabled the Timer Output signal is complemented after timer Reload. 0 = Count is captured on the rising edge of the Timer Input signal. 1 = Count is captured on the falling edge of the Timer Input signal.</p> <p>COMPARATOR COUNTER mode—If the timer is enabled the Timer Output signal is complemented after timer Reload. 0 = Count is captured on the rising edge of the Timer Input signal. 1 = Count is captured on the falling edge of the Timer Input signal.</p> <p>TRIGGERED ONE-SHOT mode—If the timer is enabled the Timer Output signal is complemented after timer Reload. 0 = The timer triggers on a Low to High transition on the input. 1 = The timer triggers on a High to Low transition on the input.</p>
[5:3] PRES		<p>The timer input clock is divided by 2^{PRES}, where PRES can be set from 0 to 7. The prescaler is reset each time the Timer is disabled. This insures proper clock division each time the Timer is restarted.</p>
	000	Divide by 1
	001	Divide by 2
	010	Divide by 4
	011	Divide by 8
	100	Divide by 16
	101	Divide by 32
	110	Divide by 64
	111	Divide by 128

Bit Position	Value (H)	Description
[2:0] TMODE[2:0]		This field along with the TMODE[3] bit in TOCTL0 register determines the operating mode of the timer. TMODE[3:0] selects from the following modes:
	0000	
	0001	ONE-SHOT mode
	0010	CONTINUOUS mode
	0011	COUNTER mode
	0100	PWM SINGLE OUTPUT mode
	0101	CAPTURE mode
	0110	COMPARE mode
	0111	GATED mode
	1000	CAPTURE/COMPARE mode
	1001	PWM DUAL OUTPUT mode
	1010	CAPTURE RESTART mode
	1011	COMPARATOR COUNTER mode
		TRIGGERED ONE-SHOT mode

LIN-UART

The Local Interconnect Network Universal Asynchronous Receiver/Transmitter (LIN-UART) is a full-duplex communication channel capable of handling asynchronous data transfers in standard UART applications as well as providing LIN protocol support.

Features of the LIN-UART include:

- 8-bit asynchronous data transfer
- Selectable even- and odd-parity generation and checking
- Option of one or two `stop` bits
- Selectable Multiprocessor (9-bit) mode with three configurable interrupt schemes
- Separate transmit and receive interrupts
- Framing, parity, overrun and break detection
- 16-bit Baud Rate Generator (BRG) which may function as a general purpose timer with interrupt
- Driver Enable output for external bus transceivers
- LIN protocol support for both master and slave modes:
 - Break generation and detection
 - Selectable Slave Autobaud
 - Check Tx versus Rx data when sending
- Configurable digital noise filter on Receive Data line

Architecture

The LIN-UART consists of three primary functional blocks: **transmitter**, **receiver**, and **BRG**. The LIN-UART's transmitter and receiver function independently, but employ the same baud rate and data format. The basic UART operation is enhanced by the Noise Filter and IrDA blocks. [Figure 11](#) displays the LIN-UART architecture.

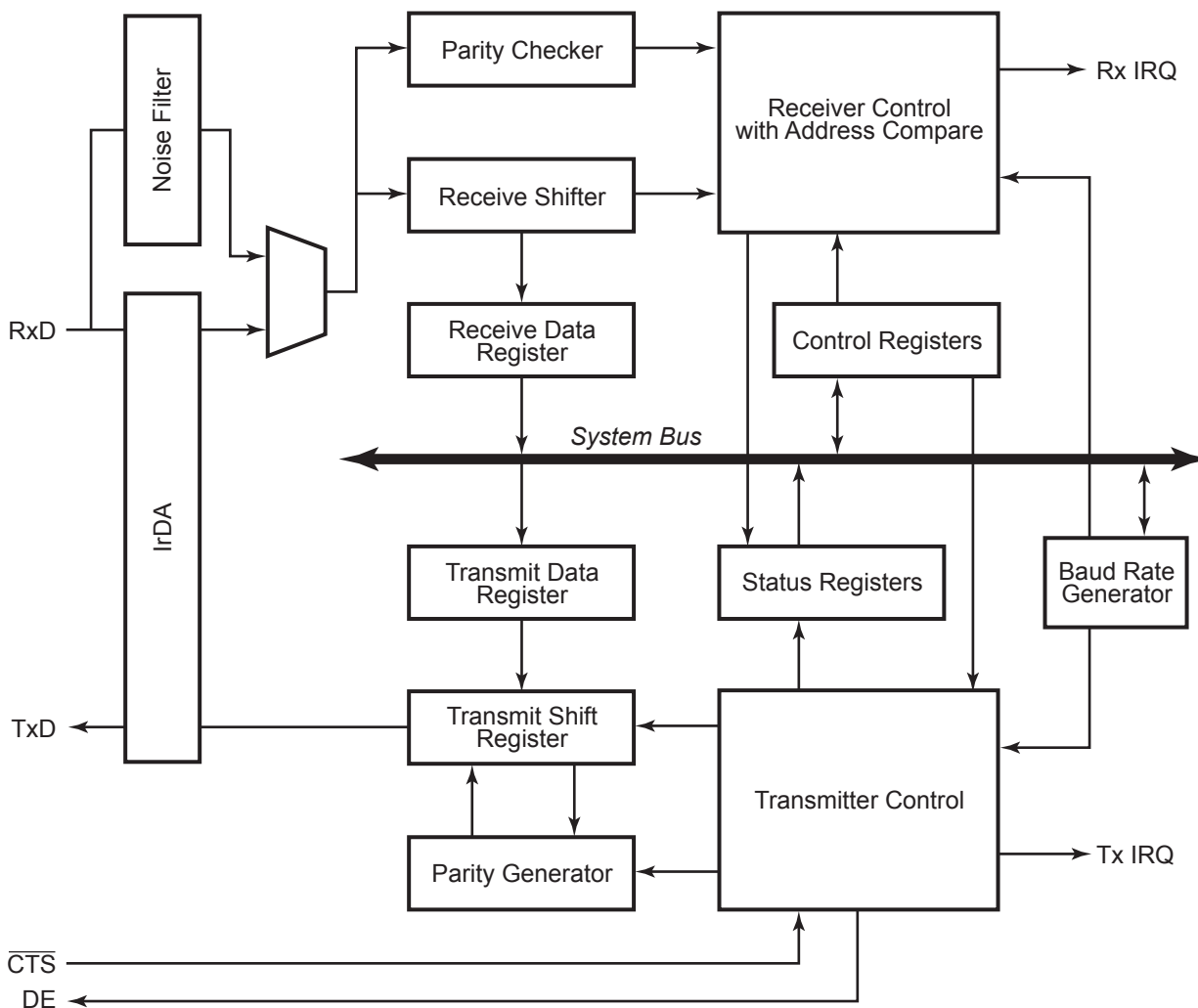

Figure 11. LIN-UART Block Diagram

Data Format for Standard UART Modes

The LIN-UART always transmits and receives data in an 8-bit data format, least-significant bit first. An even- or odd-parity bit or multiprocessor address/data bit can be optionally added to the data stream. Each character begins with an active Low start bit and ends with either 1 or 2 active High stop bits. [Figure 12](#) and [Figure 13](#) display the asynchronous data format employed by the LIN-UART without parity and with parity, respectively.

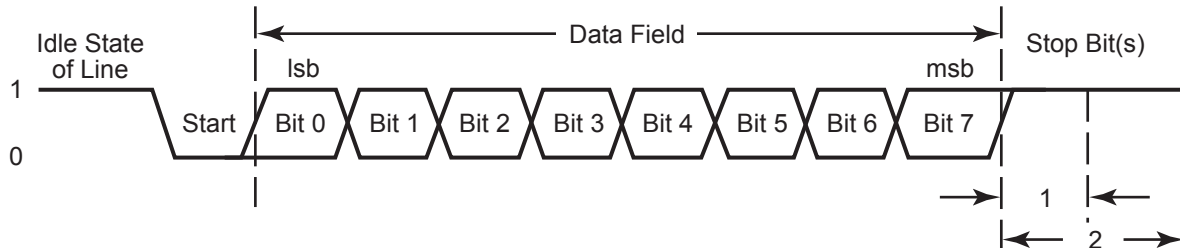

Figure 12. LIN-UART Asynchronous Data Format without Parity

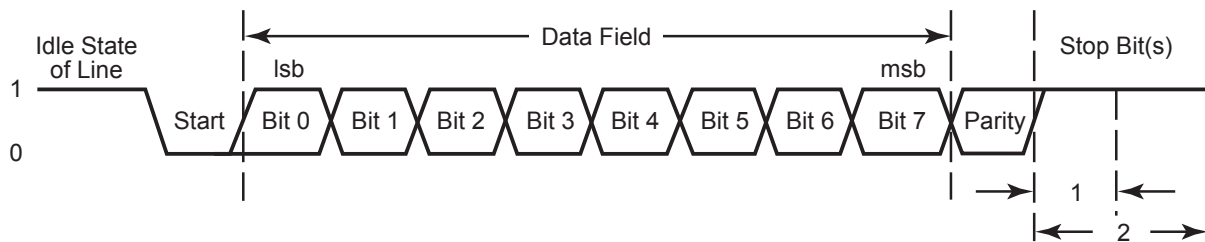

Figure 13. LIN-UART Asynchronous Data Format with Parity

Transmitting Data using Polled Method

Follow the steps below to transmit data using the polled operating method:

1. Write to the LIN-UART Baud Rate High and Low Byte registers to set the appropriate baud rate.
2. Enable the LIN-UART pin functions by configuring the associated GPIO port pins for alternate function operation.
3. If MULTIPROCESSOR mode is appropriate, write to the LIN-UART Control 1 register to enable MULTIPROCESSOR (9-bit) mode functions.

Set the MULTIPROCESSOR Mode Select ($MPEN$) to Enable MULTIPROCESSOR mode.

4. Write to the LIN-UART Control 0 register to:
 - (a) Set the transmit enable bit (TEN) to enable the LIN-UART for data transmission.
 - (b) If parity is appropriate and multiprocessor mode is not enabled, set the parity enable bit (PEN) and select either even or odd parity ($PSEL$).
 - (c) Set or clear the $CTSE$ bit to enable or disable control from the remote receiver using the \overline{CTS} pin.

5. Check the TDRE bit in the LIN-UART Status 0 register to determine if the Transmit Data register is empty (indicated by a 1). If empty, continue to Step 6. If the Transmit Data register is full (indicated by a 0), continue to monitor the TDRE bit until the Transmit Data register becomes available to receive new data.
6. If in MULTIPROCESSOR mode, write the LIN-UART Control 1 register to select the outgoing address bit. Set the Multiprocessor Bit Transmitter (MPBT) if sending an address byte; clear it if sending a data byte.
7. Write the data byte to the LIN-UART Transmit Data register. The transmitter automatically transfers the data to the Transmit Shift register and transmits the data.
8. If appropriate, and if MULTIPROCESSOR mode is enabled, make any changes to the Multiprocessor Bit Transmitter (MPBT) value.
9. To transmit additional bytes, return to Step 4.

Transmitting Data using Interrupt-Driven Method

The LIN-UART Transmitter interrupt indicates the availability of the Transmit Data register to accept new data for transmission. Follow the steps below to configure the LIN-UART for interrupt-driven data transmission:

1. Write to the LIN-UART Baud Rate High and Low Byte registers to set the appropriate baud rate.
2. Enable the LIN-UART pin functions by configuring the associated GPIO port pins for alternate function operation.
3. Execute a DI instruction to disable interrupts.
4. Write to the Interrupt control registers to enable the LIN-UART Transmitter interrupt and set the appropriate priority.
5. If multiprocessor mode is appropriate, write to the LIN-UART Control 1 register to enable Multiprocessor (9-bit) mode functions.
Set the MULTIPROCESSOR Mode Select (MPEN) to Enable MULTIPROCESSOR mode.
6. Write to the LIN-UART Control 0 register to:
 - (a) Set the transmit enable bit (TEN) to enable the LIN-UART for data transmission
 - (b) If multiprocessor mode is not enabled, enable parity, if appropriate, and select either even or odd parity.
 - (c) Set or clear the CTSE bit to enable or disable control from the remote receiver via the CTS pin.
7. Execute an EI instruction to enable interrupts.

The LIN-UART is now configured for interrupt-driven data transmission. As the LIN-UART Transmit Data register is empty, an interrupt is generated immediately. When the LIN-UART Transmit interrupt is detected, and there is transmit data ready to send, the associated interrupt service routine (ISR) performs the following:

1. If in MULTIPROCESSOR mode, write the LIN-UART Control 1 register to select the outgoing address bit:
Set the Multiprocessor Bit Transmitter (MPBT) if sending an address byte, clear it if sending a data byte.
2. Write the data byte to the LIN-UART Transmit Data register. The transmitter automatically transfers the data to the Transmit Shift register and transmits the data.
3. Execute the IRET instruction to return from the interrupt-service routine and wait for the Transmit Data register to again become empty.

If a transmit interrupt occurs and there is no transmit data ready to send, the interrupt-service routine executes the IRET instruction. When the application does have data to transmit, software can set the appropriate interrupt request bit in the Interrupt Controller to initiate a new transmit interrupt. Another alternative would be for software to write the data to the Transmit Data register instead of invoking the interrupt-service routine.

Receiving Data using Polled Method

Follow the steps below to configure the LIN-UART for polled data reception:

1. Write to the LIN-UART Baud Rate High and Low Byte registers to set the appropriate baud rate.
2. Enable the LIN-UART pin functions by configuring the associated GPIO port pins for alternate function operation.
3. Write to the LIN-UART Control 1 register to enable MULTIPROCESSOR mode functions, if appropriate.
4. Write to the LIN-UART Control 0 register to:
 - (a) Set the receive enable bit (REN) to enable the LIN-UART for data reception.
 - (b) If multiprocessor mode is not enabled, enable parity, if appropriate, and select either even or odd parity.
5. Check the RDA bit in the LIN-UART Status 0 register to determine if the Receive Data register contains a valid data byte (indicated by a 1). If RDA is set to 1 to indicate available data, continue to [Step 6](#). If the Receive Data register is empty (indicated by a 0), continue to monitor the RDA bit awaiting reception of the valid data.

6. Read data from the LIN-UART Receive Data register. If operating in MULTIPROCESSOR (9-bit) mode, further actions may be required depending on the Multiprocessor Mode bits `MPMD[1:0]`.
7. Return to [Step 5](#) to receive additional data.

Receiving Data using Interrupt-Driven Method

The LIN-UART Receiver interrupt indicates the availability of new data (as well as error conditions).

Follow the steps below to configure the LIN-UART receiver for interrupt-driven operation:

1. Write to the LIN-UART Baud Rate High and Low Byte registers to set the appropriate baud rate.
2. Enable the LIN-UART pin functions by configuring the associated GPIO port pins for alternate function operation.
3. Execute a DI instruction to disable interrupts.
4. Write to the Interrupt control registers to enable the LIN-UART Receiver interrupt and set the appropriate priority.
5. Clear the LIN-UART Receiver interrupt in the applicable Interrupt Request register.
6. Write to the LIN-UART Control 1 register to enable MULTIPROCESSOR (9-bit) mode functions, if appropriate.
 - (a) Set the MULTIPROCESSOR Mode Select (`MPEN`) to Enable Multiprocessor mode.
 - (b) Set the MULTIPROCESSOR Mode Bits, `MPMD [1 : 0]` , to select the appropriate address matching scheme.
 - (c) Configure the LIN-UART to interrupt on received data and errors or errors only (interrupt on errors only is unlikely to be useful for Z8FMC16100 Series Flash MCU devices without a DMA block)
7. Write the device address to the Address Compare register (automatic multiprocessor modes only).
8. Write to the LIN-UART Control 0 register to:
 - (a) Set the receive enable bit (`REN`) to enable the LIN-UART for data reception.
 - (b) If MULTIPROCESSOR mode is not enabled, enable parity, if appropriate, and select either even or odd parity.
9. Execute an EI instruction to enable interrupts.

The LIN-UART is now configured for interrupt-driven data reception. When the LIN-UART Receiver interrupt is detected, the associated ISR performs the following:

1. Check the LIN-UART Status 0 register to determine the source of the interrupt-error, break, or received data.
2. If the interrupt was due to data available, read the data from the LIN-UART Receive Data register. If operating in MULTIPROCESSOR (9-bit) mode, further actions may be required depending on the multiprocessor mode bits `MPMD[1:0]`.
3. Execute the IRET instruction to return from the interrupt-service routine and await more data.

Clear To Send Operation

The Clear To Send ($\overline{\text{CTS}}$) pin, if enabled by the `CTSE` bit of the LIN-UART Control 0 register, performs flow control on the outgoing transmit data stream. The Clear To Send ($\overline{\text{CTS}}$) input pin is sampled one system clock before beginning any new character transmission. To delay transmission of the next data character, an external receiver must deassert $\overline{\text{CTS}}$ at least one system clock cycle before a new data transmission begins. For multiple character transmissions, this operation is typically performed during the Stop Bit transmission. If $\overline{\text{CTS}}$ deasserts in the middle of a character transmission, the current character is sent completely.

External Driver Enable

The LIN-UART provides a Driver Enable (DE) signal for off-chip bus transceivers. This feature reduces the software overhead associated with using a GPIO pin to control the transceiver when communicating on a multitransceiver bus, such as RS-485.

Driver Enable is a programmable polarity signal that envelopes the entire transmitted data frame including parity and Stop bits as displayed in [Figure 14](#). The Driver Enable signal asserts when a byte is written to the LIN-UART Transmit Data register. The Driver Enable signal asserts at least one bit period and no greater than two bit periods before the Start bit is transmitted. This allows a setup time to enable the transceiver.

The Driver Enable signal deasserts one system clock period after the last `STOP` bit is transmitted. This one system clock delay allows both time for data to clear the transceiver before disabling it, as well as the ability to determine if another character follows the current character. In the event of back to back characters (new data must be written to the Transmit Data register before the previous character is completely transmitted) the DE signal is not deasserted between characters. The `DEPOL` bit in the LIN-UART Control register 1 sets the polarity of the Driver Enable signal.

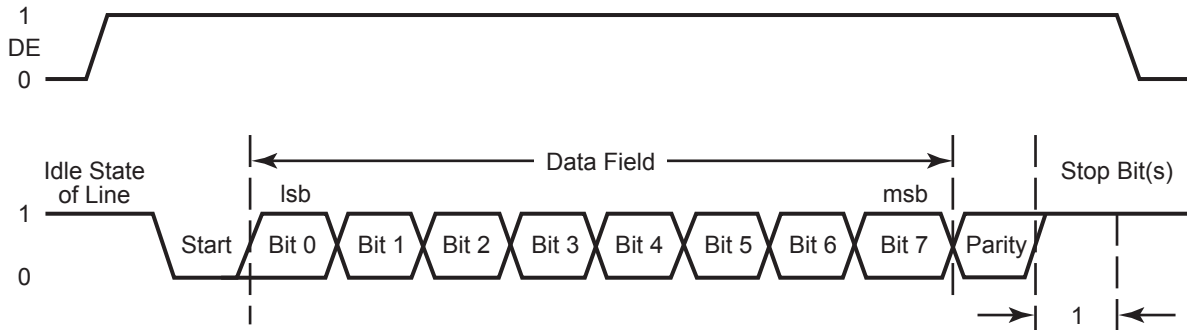

Figure 14. LIN-UART Driver Enable Signal Timing (shown with 1 Stop Bit and Parity)

The Driver Enable to START bit set-up time is calculated as follows:

$$\frac{1}{\text{Baud Rate (Hz)}} \leq \text{DE to Start Bit Setup Time(s)} \leq \frac{2}{\text{Baud Rate (Hz)}}$$

LIN-UART Special Modes

The special modes of the LIN-UART are:

- [MULTIPROCESSOR Mode](#)
- [LIN Protocol Mode](#)

The LIN-UART features a common control register (Control 0) that contains a unique register address and several mode-specific control registers (Multiprocessor Control, Noise Filter Control, and LIN Control) that share a common register address (Control 1). When the Control 1 address is read or written, the `MSEL[2:0]` (Mode Select) field of the Mode Select and Status register determines which physical register is accessed. Similarly, there are mode-specific status registers, one of which is returned when the Status 0 register is read, depending on the `MSEL` field.

MULTIPROCESSOR Mode

The LIN-UART features a MULTIPROCESSOR (9-bit) mode that uses an extra (9th) bit for selective communication when a number of processors share a common UART bus. In MULTIPROCESSOR mode (also referred to as 9-Bit mode), the multiprocessor bit (MP) is transmitted immediately following the 8 bits of data and immediately preceding the stop bit(s) as displayed in [Figure 15](#).

The character format is given below.

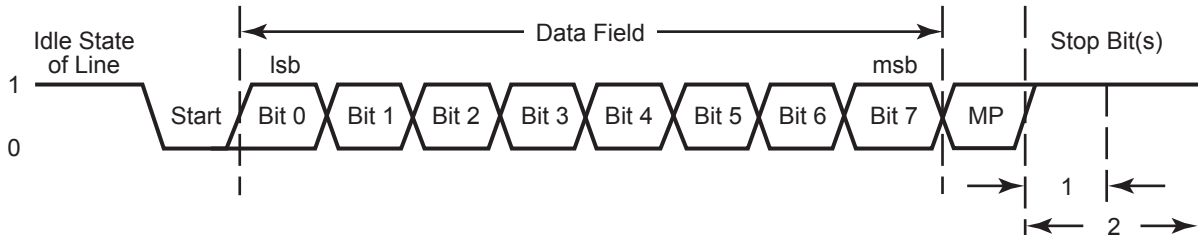

Figure 15. LIN-UART Asynchronous MULTIPROCESSOR Mode Data Format

In MULTIPROCESSOR (9-bit) mode, the Parity bit location (9th bit) becomes the MULTIPROCESSOR control bit. The LIN-UART Control 1 and Status 1 registers provide MULTIPROCESSOR (9-bit) mode control and status information. If an automatic address matching scheme is enabled, the LIN-UART Address Compare register holds the network address of the device.

MULTIPROCESSOR Mode Receive Interrupts

When MULTIPROCESSOR (9-bit) mode is enabled, the LIN-UART processes only frames addressed to it. The determination of whether a frame of data is addressed to the LIN-UART can be made in hardware, software or a combination of the two, depending on the multiprocessor configuration bits. In general, the address compare feature reduces the load on the CPU, as it does not need to access the LIN-UART when it receives data directed to other devices on the multinode network. The following 3 MULTIPROCESSOR modes are available in hardware:

1. Interrupt on all address bytes
2. Interrupt on matched address bytes and correctly framed data bytes
3. Interrupt only on correctly framed data bytes

These modes are selected with MPMD [1 : 0] in the LIN-UART Control 1 register. For all MULTIPROCESSOR modes, bit MPEN of the LIN-UART Control 1 register must be set to 1.

The first scheme is enabled by writing 01b to MPMD [1 : 0]. In this mode, all incoming address bytes cause an interrupt, while data bytes never cause an interrupt. The interrupt service routine checks the address byte which triggered the interrupt. If it matches the LIN-UART address, the software clears MPMD [0]. At this point, each new incoming byte interrupts the CPU. The software determines the end of the frame and checks for it by reading the MPRX bit of the LIN-UART Status 1 register for each incoming byte. If MPRX=1, a new frame has begun. If the address of this new frame is different from the LIN-UART's address, then MPMD [0] must be set to 1 by software, causing the LIN-

UART interrupts to go inactive until the next address byte. If the new frame's address matches the LIN-UART's, then the data in the new frame is processed.

The second scheme is enabled by setting `MPMD[1:0]` to `10B` and writing the LIN-UART's address into the LIN-UART Address Compare register. This mode introduces more hardware control, interrupting only on frames that match the LIN-UART's address. When an incoming address byte does not match the LIN-UART's address, it is ignored. All successive data bytes in this frame are also ignored. When a matching address byte occurs, an interrupt is issued and further interrupts occur on each successive data byte. The first data byte in the frame has `NEWFRM=1` in the LIN-UART Status 1 register. When the next address byte occurs, the hardware compares it to the LIN-UART's address. If there is a match, the interrupt occurs and the `NEWFRM` bit is set for the first byte of the new frame. If there is no match, the LIN-UART ignores all incoming bytes until the next address match.

The third scheme is enabled by setting `MPMD[1:0]` to `11B` and by writing the LIN-UART's address into the LIN-UART Address Compare register. This mode is identical to the second scheme, except that there are no interrupts on address bytes. The first data byte of each frame remains accompanied by a `NEWFRM` assertion.

LIN Protocol Mode

The LIN protocol as supported by the LIN-UART module is defined in revision 2.0 of the LIN Specification Package. The LIN protocol specification covers all aspects of transferring information between LIN Master and Slave devices using *message frames* including error detection and recovery, sleep mode and wake up from sleep mode. The LIN-UART hardware in LIN mode provides character transfers to support the LIN protocol including BREAK transmission and detection, WAKE-UP transmission and detection, and slave autobauding. Part of the error detection of the LIN protocol is for both master and slave devices to monitor their receive data when transmitting.

If the receive and transmit data streams do not match, the LIN-UART asserts the `PLE` bit (physical layer error bit in Status0 register). The *message frame* timeout aspect of the protocol is left to software, requiring the use of an additional general purpose timer. The LIN mode of the LIN-UART does not provide any hardware support for computing/verifying the checksum field or verifying the contents of the Identifier field. These fields are treated as data and are not interpreted by hardware. The checksum calculation/verification can easily be implemented in software through the ADC (Add with Carry) instruction.

The LIN bus contains a single master and one or more slaves. The LIN master is responsible for transmitting the message frame header which consists of the Break, Synch and Identifier fields. Either the master or one of the slaves transmits the associated *response* section of the message which consists of data characters followed by a checksum character.

In LIN mode, the interrupts defined for normal UART operation still apply with the following changes.

- Parity Error (PE bit in Status0 register) is redefined as the Physical Layer Error (PLE) bit. The PLE bit indicates that receive data does not match transmit data when the LIN-UART is transmitting. This applies to both Master and Slave operating modes.
- The Break Detect interrupt (BRKD bit in Status0 register) indicates when a Break is detected by the slave (break condition for at least 11 bit times). Software can use this interrupt to start a timer checking for message frame timeout. The duration of the break can be read in the `RxBreakLength[3:0]` field of the Mode Status register.
- The Break Detect interrupt (BRKD bit in Status0 register) indicates when a Wake-up message has been received if the LIN-UART is in LinSleep state.
- In LIN slave mode, if the BRG counter overflows while measuring the autobaud period (Start bit to beginning of bit 7 of autobaud character) an Overrun Error is indicated (OE bit in the Status0 register). In this case, software sets the LinState field back to 10b, where the Slave ignores the current message and waits for the next Break. The Baud Reload High and Low registers are not updated by hardware if this autobaud error occurs. The OE bit is also set if a data overrun error occurs.

LIN System Clock Requirements

The LIN master provides the timing reference for the LIN network and is required to have a clock source with a tolerance of $\pm 0.5\%$. A slave with autobaud capability is required to have a baud clock matching the master oscillator within $\pm 14\%$. The slave nodes autobaud to lock onto the master timing reference with an accuracy of $\pm 2\%$. If a Slave does not contain autobaud capability it must include a baud clock which deviates from the masters by no more than $\pm 1.5\%$. These accuracy requirements must include effects such as voltage and temperature drift during operation.

Before sending or receiving messages, the Baud Reload High/Low registers must be initialized. Unlike standard UART modes, the Baud Reload High/Low registers must be loaded with the baud interval rather than 1/16 of the baud interval.

In order to autobaud with the required accuracy, the LIN slave system clock must be at least 100 times the baud rate.

LIN Mode Initialization and Operation

The LIN protocol mode is selected by setting either the LMST (LIN Master) or LSLV (LIN Slave), and optionally (for LIN slave) the Autobaud Enable (ABEN) bits in the LIN Control register. To access the LIN Control register, the MSEL (Mode Select) field of the LIN-UART Mode Select/Status register must be = 010B. The LIN-UART Control0 register must be initialized with TEN = 1, REN = 1, all other bits = 0.

In addition to the LMST, LSLV and ABEN bits in the LIN Control register, a LinState[1:0] field exists that defines the current state of the LIN logic. This field is initially set by

software. In the LIN Slave mode, the `LinState` field is updated by hardware as the Slave moves through the Wait For Break, AutoBaud, and Active states.

The Noise Filter may also need to be enabled and configured when interfacing to a LIN bus.

LIN MASTER Mode Operation

LIN MASTER mode is selected by setting `LMST = 1`, `LSLV = 0`, `ABEN = 0`, `LinState[1:0] = 11B`. If the LIN bus protocol indicates the bus is required go into the *LIN sleep* state, the `LinState[1:0]` bits must be set = `00B` by software.

The Break is the first part of the message frame transmitted by the master, consisting of at least 13 bit periods of logical zero on the LIN bus. During initialization of the LIN master, the duration (in bit times) of the Break is written to the `TxBreakLength` field of the LIN Control register. The transmission of the Break is performed by setting the `SBRK` bit in the Control 0 register. The LIN-UART starts the Break once the `SBRK` bit is set and any character transmission currently underway has completed. The `SBRK` bit is deasserted by hardware once the break is completed.

The Synch character is transmitted by writing a `55H` to the Transmit Data register (`TDRE` must = 1 before writing). The Synch character is not transmitted by the hardware until after the Break is complete.

The Identifier character is transmitted by writing the appropriate value to the Transmit Data register (`TDRE` must = 1 before writing).

If the master is sending the *response* portion of the message, these data and checksum characters are written to the Transmit Data register when the `TDRE` bit asserts. If the transmit data register is written after `TDRE` asserts, but before `TXE` asserts, the hardware inserts one or two stop bits between each character as determined by the `STOP` bit in the Control0 register. Additional idle time occurs between characters if `TXE` asserts before the next character is written.

If the selected slave is sending the response portion of the frame to the master, each receive byte is signalled by the receive data interrupt (`RDA` bit is set in the Status0 register).

If the selected slave is sending the response to a different slave, the master can ignore the response characters by deasserting the `REN` bit in the Control0 register until the frame time slot has completed.

LIN Sleep Mode

While the LIN bus is in the *sleep* state, the CPU can be in either low power STOP mode, in HALT mode, or in normal operational state. Any device on the LIN bus may issue a Wake-up message if it requires the master to initiate a LIN message frame. Following the Wake-up message, the master wakes up and initiates a new message. A Wake-up message is accomplished by pulling the bus low for at least 250 μ s but less than 5 ms. Transmitting a `00h` character is one way to transmit the wake-up message.

If the CPU is in STOP mode, the LIN-UART is not active and the Wake-up message must be detected by a GPIO edge detect Stop Mode Recovery. The duration of the Stop Mode Recovery sequence may preclude making an accurate measurement of the Wake-up message duration.

If the CPU is in HALT or operational mode, the LIN-UART (if enabled) times the duration of the Wake-up and provides an interrupt following the end of the break sequence if the duration is ≥ 3 bit times. The total duration of the Wake-up message in bit times may be obtained by reading the `RxBreakLength` field in the Mode Status register. After a Wake-up message has been detected, the LIN-UART can be placed (by software) into either *LIN Master* or *LIN Slave Wait for Break* states as appropriate. If the break duration exceeds 15 bit times, the `RxBreakLength` field contains the value `Fh`. If the LIN-UART is disabled, the Wake-up message can be detected via a port pin interrupt and timed by software. If the device is in STOP mode, the High to Low transition on the port pin bring the device out of STOP mode.

The *LIN Sleep* state is selected by software setting `LinState[1:0] = 00`. The decision to move from an active state to sleep state is based on the LIN messages as interpreted by software.

LIN Slave Operation

LIN Slave mode is selected by setting `LMST = 0`, `LSLV = 1`, `ABEN = 1` or `0` and `LinState[1:0] = 01b` (Wait for Break State). The LIN slave detects the start of a new message by the Break which appears to the Slave as a break of at least 11 bit times in duration. The LIN-UART detects the Break and generates an interrupt to the CPU. The duration of the Break is observable in the `RxBreakLength` field of the Mode Status register. A Break of less than 11 bit times in duration does not generate a break interrupt when the LIN-UART is in *Wait for Break* state. If the Break duration exceeds 15 bit times, the `RxBreakLength` field contains the value `Fh`.

Following the Break the LIN-UART hardware automatically transits to the *Autobaud* state, where it autobauds by timing the duration of the first 8 bit times of the Synch character as defined in the standard. At the end of the autobaud period, the duration measured by the BRG counter (auto baud period divided by 8) is automatically transferred to the Baud Reload High and Low registers if the `ABEN` bit of the LIN control register is set. If the BRG Counter overflows before reaching the start of bit 7 in the autobaud sequence the Autobaud Overrun Error interrupt occurs, the `OE` bit in the Status0 register is set and the Baud Reload registers are not updated. To autobaud within 2% of the master's baud rate, the slave system clock must be minimum 100 times the baud rate. To avoid an autobaud overrun error, the system clock must not be greater than 2^{19} times the baud rate (16 bit counter following 3-bit prescaler when counting the 8 bit times of the Autobaud sequence).

Following the Synch character, the LIN-UART hardware transits to the *Active* state where the Identifier character is received and the characters of the *Response* section of the message are sent or received. The Slave remains in the *Active* state until a Break is

received or software forces a state change. When it is in Active State (autobaud has completed), a Break of 10 or more bit times is recognized and will cause a transition to the Autobaud state.

If the Identifier character indicates that this slave device is not participating in the message, software can set the `LinState[1:0] = 01b` (Wait for Break State) to ignore the rest of the message. No further receive interrupts will occur until the next Break.

LIN-UART Interrupts

The LIN-UART features separate interrupts for the transmitter and receiver. In addition, when the LIN-UART primary functionality is disabled, the BRG can also function as a basic timer with interrupt capability.

Transmitter Interrupts

The transmitter generates a single interrupt when the Transmit Data register Empty bit (TDRE) is set to 1. This indicates that the transmitter is ready to accept new data for transmission. The TDRE interrupt occurs when the transmitter is initially enabled and after the Transmit shift register has shifted the first bit of a character out. At this point, the Transmit Data register may be written with the next character to send. This provides 7 bit periods of latency to load the Transmit Data register before the Transmit shift register completes shifting the current character. Writing to the LIN-UART Transmit Data register clears the TDRE bit to 0.

Receiver Interrupts

The receiver generates an interrupt when any of the following occurs:

- A data byte is received and is available in the LIN-UART Receive Data register. This interrupt can be disabled independent of the other receiver interrupt sources through the `RDAIRQ` bit (this feature is useful in devices which support DMA). The received data interrupt occurs after the receive character is placed in the Receive Data register. Software must respond to this received data available condition before the next character is completely received to avoid an overrun error.

► **Note:** *In MULTIPROCESSOR mode (`MPEN = 1`), the receive data interrupts are dependent on the multiprocessor configuration and the most recent address byte.*

- A break is received.
- A receive data overrun or LIN slave autobaud overrun error is detected.
- A data framing error is detected.
- A parity error is detected (physical layer error in LIN mode).

LIN-UART Overrun Errors

When an overrun error condition occurs the LIN-UART prevents overwriting of the valid data currently in the Receive Data register. The Break Detect and Overrun status bits are not displayed until the valid data has been read.

After the valid data has been read, the OE bit of the Status 0 register is updated to indicate the overrun condition (and Break Detect, if applicable). The RDA bit is set to 1 to indicate that the Receive Data register contains a data byte. However, because the overrun error occurred, this byte may not contain valid data and must be ignored. The BRKD bit indicates if the overrun is caused due to a break condition on the line. After reading the status byte indicating an overrun error, the Receive Data register must be read again to clear the error bits in the LIN-UART Status 0 register.

In LIN mode, an Overrun Error is signaled for receive data overruns as described above and in the LIN Slave if the BRG Counter overflows during the autobaud sequence (the ATB bit will also be set in this case). There is no data associated with the autobaud overflow interrupt, however the Receive Data register must be read to clear the OE bit. In this case software must write a 10B to the `LinState` field, forcing the LIN slave back to a *Wait for Break* state.

LIN-UART Data-Handling and Error-Handling Procedure

Figure 16 displays the recommended procedure for use in LIN-UART receiver interrupt service routines.

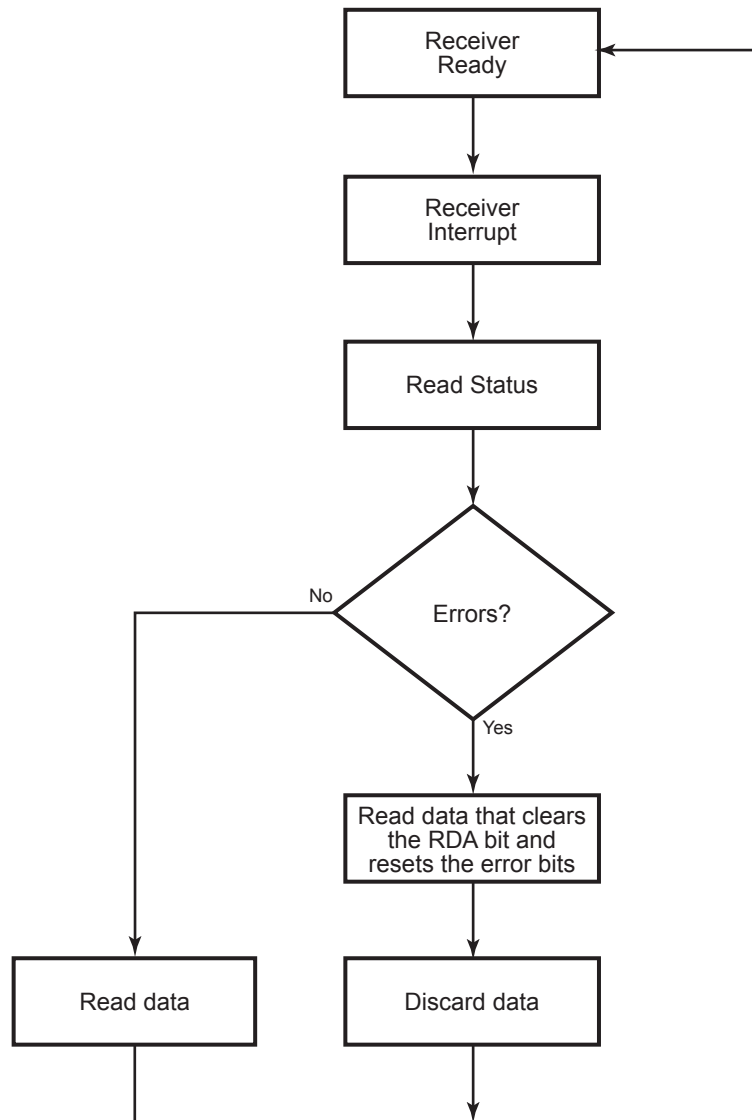

Figure 16. LIN-UART Receiver Interrupt Service Routine Flow

Baud Rate Generator Interrupts

If the `BRGCTL` bit of the Multiprocessor Control register (LIN-UART Control 1 register with `MSEL = 000b`) register is set, and the `REN` bit of the Control 0 register is 0, the LIN-UART Receiver interrupt asserts when the LIN-UART Baud Rate Generator reloads. This allows the BRG to function as an additional counter if the LIN-UART receiver functionality is not employed. The transmitter is enabled in this mode.

LIN-UART Baud Rate Generator

The LIN-UART Baud Rate Generator creates a lower frequency baud rate clock for data transmission. The input to the Baud Rate Generator is the system clock. The LIN-UART Baud Rate High and Low Byte registers combine to create a 16-bit baud rate divisor value ($BRG[15:0]$) that sets the data transmission rate (baud rate) of the LIN-UART. The LIN-UART data rate is calculated using the following equation for normal UART operation:

$$\text{UART Data Rate (bps)} = \frac{\text{System Clock Frequency (Hz)}}{16 \times \text{UART Baud Rate Divisor Value}}$$

The LIN-UART data rate is calculated using the below equation for LIN mode UART operation:

$$\text{UART Data Rate (bps)} = \frac{\text{System Clock Frequency (Hz)}}{\text{UART Baud Rate Divisor Value}}$$

When the LIN-UART is disabled, the Baud Rate Generator can function as a basic 16-bit timer with interrupt on timeout. To configure the Baud Rate Generator as a timer with interrupt on timeout, complete the below procedure:

1. Disable the LIN-UART receiver by clearing the `REN` bit in the LIN-UART Control 0 register to 0 (`TEN` bit may be asserted, transmit activity may occur).
2. Load the appropriate 16-bit count value into the LIN-UART Baud Rate High and Low Byte registers.
3. Enable the Baud Rate Generator timer function and associated interrupt by setting the `BRGCTL` bit in the LIN-UART Control 1 register to 1.

Noise Filter

A noise filter circuit is included which filters noise on a digital input signal (such as UART Receive Data) before the data is sampled by the block. This is likely to be a requirement for protocols with a noisy environment.

The noise filter contains the following features:

- Synchronizes the receive input data to the System Clock.
- Noise Filter Enable (`NFEN`) input selects whether the noise filter is bypassed (`NFEN = 0`) or included (`NFEN = 1`) in the receive data path.
- Noise Filter Control (`NFCTL[2:0]`) input selects the width of the up/down saturating counter digital filter. The available widths range from 4 bits to 11 bits.

- The digital filter output features hysteresis.
- Provides an active low *Saturated State* output (`FiltSatB`) used as an indication of the presence of noise.

Architecture

Figure 17 displays how the noise filter is integrated with the LIN-UART for use on a LIN network.

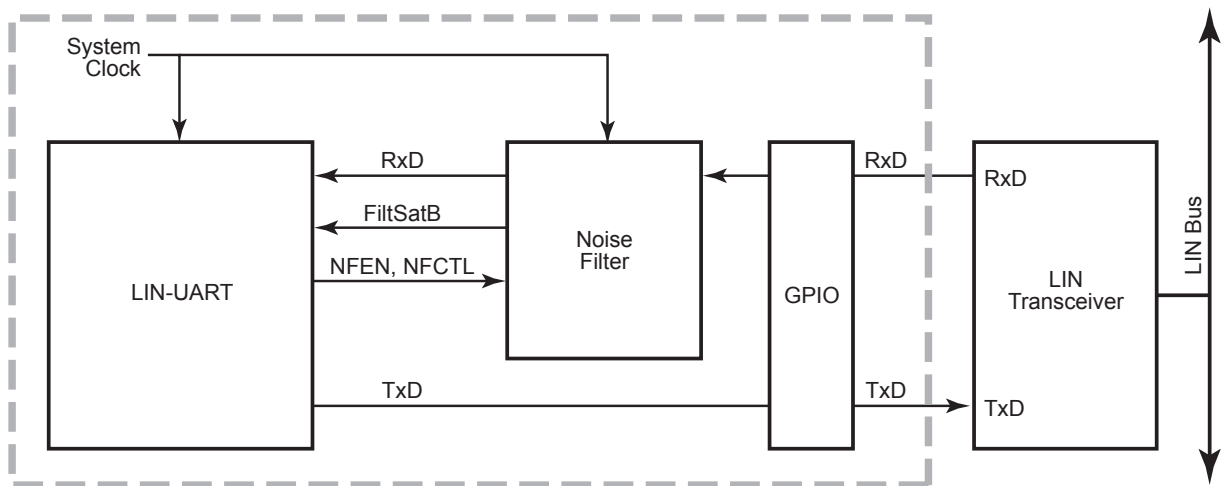

Figure 17. Noise Filter System Block Diagram

Operation

Figure 18 displays the operation of the noise filter both with and without noise. The noise filter in this example is a 2-bit up/down counter which saturates at `00b` and `11b`. A 2-bit counter is shown for convenience, the operation of wider counters is similar. The output of the filter switches from 1 to 0 when the counter counts down from `01b` to `00b` and switches from 0 to 1 when the counter counts up from `10b` to `11b`. The noise filter delays the receive data by three System Clock cycles.

The `FiltSatB` signal is checked when the filtered `RxD` is sampled in the center of the bit time. The presence of noise (`FiltSatB = 1` at center of bit time) does not mean the sampled data is incorrect, just that the filter is not in its "saturated" state of all 1's or all 0's. If `FiltSatB = 1`, when `RxD` is sampled during a receive character, the `NE` bit in the `ModeStatus[4:0]` field is set. By observing this bit, an indication of the level of noise in the network can be obtained.

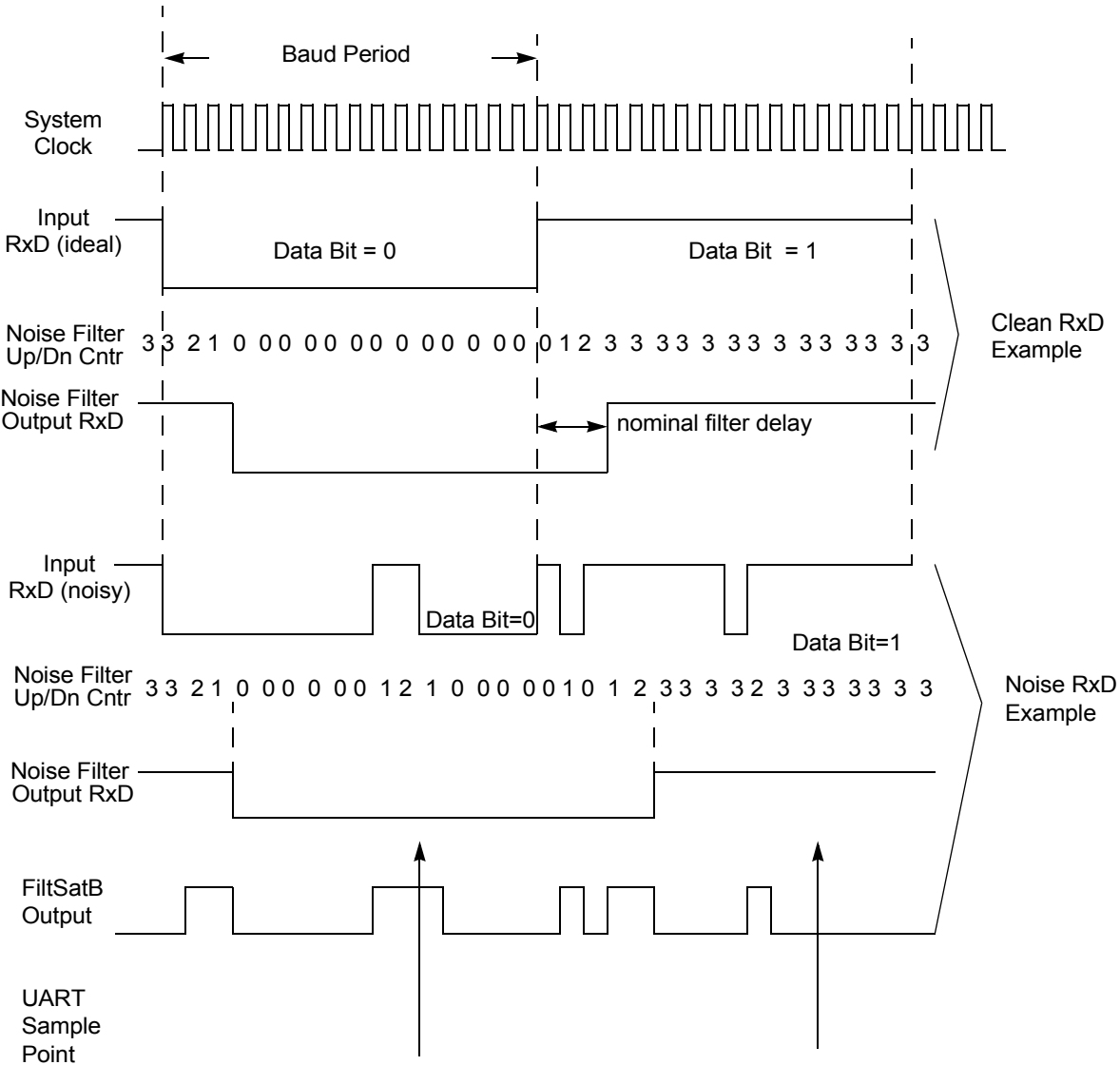

Figure 18. Noise Filter Operation

LIN-UART Control Register Definitions

The LIN-UART control registers support the LIN-UART, the associated Infrared Encoder/Decoder and the noise filter. For more information on the infrared operation, see [Infrared Encoder/Decoder](#) on page 143.

LIN-UART Transmit Data Register

Data bytes written to the LIN-UART Transmit Data register ([Table 66](#)) are shifted out on the TxD pin. The Write-only LIN-UART Transmit Data register shares a Register File address with the read-only LIN-UART Receive Data register.

Table 66. LIN-UART Transmit Data Register (U0TXD)

BITS	7	6	5	4	3	2	1	0
FIELD	TXD							
RESET	X							
R/W	W							
ADDR	F40H							

TXD—Transmit Data

LIN-UART transmitter data byte to be shifted out through the TXD pin.

LIN-UART Receive Data Register

Data bytes received through the RxD pin are stored in the LIN-UART Receive Data register ([Table 67](#)). The read-only LIN-UART Receive Data register shares a Register File address with the Write-only LIN-UART Transmit Data register.

Table 67. LIN-UART Receive Data Register (U0RXD)

BITS	7	6	5	4	3	2	1	0
FIELD	RXD							
RESET	X							
R/W	R							
ADDR	F40H							

RXD—Receive Data

LIN-UART receiver data byte from the RXD pin

LIN-UART Status 0 Register

The LIN-UART Status 0 register identifies the current LIN-UART operating configuration and status. [Table 68](#) describes the Status 0 register for standard UART mode. [Table 69](#) on page 130 describes the Status0 register for LIN mode.

Table 68. LIN-UART Status 0 Register – Standard UART Mode (U0STAT0)

BITS	7	6	5	4	3	2	1	0
FIELD	RDA	PE	OE	FE	BRKD	TDRE	TXE	CTS
RESET	0	0	0	0	0	1	1	X
R/W	R	R	R	R	R	R	R	R
ADDR	F41H							

Receive Data Available (RDA)—This bit indicates that the LIN-UART Receive Data register has received data. Reading the LIN-UART Receive Data register clears this bit.

Parity Error (PE)—This bit indicates that a parity error has occurred. Reading the Receive Data register clears this bit.

Overrun Error (OE)—This bit indicates that an overrun error has occurred. An overrun occurs when new data is received and the Receive Data register has not been read. Reading the Receive Data register clears this bit.

Framing Error (FE)—This bit indicates that a framing error (no STOP bit following data reception) is detected. Reading the Receive Data register clears this bit.

Break Detect (BRKD)—This bit indicates that a break has occurred. If the data bits, parity/multiprocessor bit, and STOP bit(s) are all zeros then this bit is set to 1. Reading the Receive Data register clears this bit.

Transmitter Data Register Empty (TDRE)—This bit indicates that the Transmit Data register is empty and ready for additional data. Writing to the Transmit Data register resets this bit.

Transmitter Empty (TXE)—This bit indicates that the transmit shift register is empty and character transmission is finished.

Clear To Send Signal ($\overline{\text{CTS}}$)—When this bit is read it returns the level of the $\overline{\text{CTS}}$ signal. If LBEN = 1, the CTS input signal is replaced by the internal Receive Data Available signal to provide flow control in loopback mode. CTS only affects transmission if the CTSE bit = 1.

Table 69. LIN-UART Status 0 Register - LIN mode (U0STAT0)

BITS	7	6	5	4	3	2	1	0
FIELD	RDA	PLE	ABOE	FE	BRKD	TDRE	TXE	ATB
RESET	0	0	0	0	0	1	1	0
R/W	R	R	R	R	R	R	R	R
ADDR	F41H							

Receive Data Available (RDA)—This bit indicates that the Receive Data register has received data. Reading the Receive Data register clears this bit.

Physical Layer Error (PLE)—This bit indicates that transmit and receive data do not match when a LIN slave or master is transmitting. This could be caused by a fault in the physical layer or multiple devices driving the bus simultaneously. Reading the Status 0 register or the Receive Data register clears this bit.

Receive Data and Autobaud Overrun Error (OE)—This bit is set just as in normal UART operation if a receive data overrun error occurs. This bit is also set during LIN Slave autobaud if the BRG counter overflows before the end of the autobaud sequence, indicating the receive activity was not an autobaud character or the master baud rate is too slow. The ATB status bit will also be set in this case. This bit is cleared by reading the Receive Data register.

Framing Error (FE)—This bit indicates that a framing error (no STOP bit following data reception) was detected. Reading the Receive Data register clears this bit.

Break Detect (BRKD)—This bit is set in LIN mode if (a) in LinSleep state and a break of at least 4 bit times occurred (Wake-up event) or (b) in Slave Wait Break state and a break of at least 11 bit times occurred (Break event) or (c) in Slave Active state and a break of at least 10 bit times occurs. Reading the Status 0 register or the Receive Data register clears this bit.

Transmitter Data Register Empty (TDRE)—This bit indicates that the Transmit Data register is empty and ready for additional data. Writing to the Transmit Data register resets this bit.

Transmitter Empty (TXE)—This bit indicates that the transmit shift register is empty and character transmission is finished.

LIN Slave Autobaud Complete (ATB)—This bit is set in LIN SLAVE mode when an autobaud character is received. If the ABIEN bit is set in the LIN Control register, then a receive interrupt is generated when this bit is set. Reading the Status 0 register clears this bit. This bit will be 0 in LIN MASTER mode.

LIN-UART Mode Select and Status Register

The LIN-UART Mode Select and Status register (Table 70) contains mode select and status bits. A more detailed discussion of each bit follows the table.

Table 70. LIN-UART Mode Select and Status Register (U0MDSTAT)

BITS	7	6	5	4	3	2	1	0
FIELD	MSEL			Mode Status				
RESET	0	0	0	0	0	0	0	0
R/W	R/W	R/W	R/W	R	R	R	R	R
ADDR	F44H							

MSEL—Mode Select

This R/W field determines which control register is accessed when performing a write or read to the Uart Control 1 register address. This field also determines which status is returned in the ModeStatus field when reading this register.

000 = Multiprocessor and normal UART control/status

001 = Noise Filter control/status

010 = LIN Protocol control/status

011–110: reserved

111 = LIN-UART Hardware Revision (allows hardware revision to be read in the Mode Status field)

Mode Status. This read-only field returns status corresponding to the mode selected by MSEL as follows:

000: Multiprocessor and normal UART mode status = {NE, 0, 0, NEWFRM, MPRX}

001: Noise Filter status = {NE, 0, 0, 0, 0}

010: LIN mode status = {NE, RxBreakLength[3:0]}

011–110: reserved = {0, 0, 0, 0, 0}

111: LIN-UART hardware revision

MULTIPROCESSOR Mode Status field (MSEL = 000B)

NE—Noise Event. This bit is asserted if digital noise is detected on the receive data line while the data is sampled (center of bit time). If this bit is set, it does not mean that the receive data is corrupted (though it may be in extreme cases), just that one or more of the noise filter data samples near the center of the bit time did not match the average data value.

NEWFRM—Status bit denoting the start of a new frame. Reading the LIN-UART Receive Data register resets this bit to 0.

0 = The current byte is not the first data byte of a new frame.

1 = The current byte is the first data byte of a new frame.

MPRX—Multiprocessor Receive

Returns the value of the last multiprocessor bit received. Reading from the LIN-UART Receive Data register resets this bit to 0.

Digital Noise Filter Mode Status Field (MSEL = 001B)

NE—Noise Event. This bit is asserted if digital noise is detected on the receive data line while the data is sampled (center of bit time). If this bit is set, it does not mean that the receive data is corrupted (though it may be in extreme cases), just that one or more of the noise filter data samples near the center of the bit time did not match the average data value.

LIN Mode Status Field (MSEL = 010B)

NE—Noise Event. This bit is asserted if some noise level is detected on the receive data line while the data is sampled (center of bit time). If this bit is set, it does not indicate that the receive data is corrupt (though it may be in extreme cases), just that one or more of the 16x data samples near the center of the bit time did not match the average data value.

RxBreakLength—LIN mode received break length. This field may be read following a break (LIN WAKE-UP or BREAK) so software can determine the measured duration of the break. If the break exceeds 15 bit times the value saturates at 1111B.

Hardware Revision Mode Status Field (MSEL = 111B)

This field indicates the hardware revision of the LIN-UART block.

00_xxx LIN UART hardware rev

01_xxx Reserved

10_xxx Reserved

11_xxx Reserved

LIN-UART Control 0 Register

The LIN-UART Control 0 register (Table 71) configures the basic properties of the LIN-UART's transmit and receive operations. A more detailed discussion of each bit follows the table.

Table 71. LIN-UART Control 0 Register (U0CTL0)

BITS	7	6	5	4	3	2	1	0
FIELD	TEN	REN	CTSE	PEN	PSEL	SBRK	STOP	LBEN
RESET	0	0	0	0	0	0	0	0
R/W	R/W	R/W	R/W	R/W	R/W	R/W	R/W	R/W
ADDR	F42H							

TEN—Transmit Enable

This bit enables or disables the transmitter. The enable is also controlled by the $\overline{\text{CTS}}$ signal and the CTSE bit. If the $\overline{\text{CTS}}$ signal is Low and the CTSE bit is 1, the transmitter is enabled.
0 = Transmitter disabled.
1 = Transmitter enabled.

REN—Receive Enable

This bit enables or disables the receiver.
0 = Receiver disabled.
1 = Receiver enabled.

CTSE—CTS Enable

0 = The $\overline{\text{CTS}}$ signal has no effect on the transmitter.
1 = The LIN-UART recognizes the $\overline{\text{CTS}}$ signal as an enable control for the transmitter.

PEN—Parity Enable

This bit enables or disables parity. Even or odd is determined by the PSEL bit.
0 = Parity is disabled. This bit is overridden by the MPEN bit.
1 = The transmitter sends data with an additional parity bit and the receiver receives an additional parity bit.

PSEL—Parity Select

0 = Even parity is transmitted and expected on all received data.
1 = Odd parity is transmitted and expected on all received data.

SBRK—Send Break

This bit pauses or breaks data transmission. Sending a break interrupts any transmission in progress, so ensure that the transmitter has finished sending data before setting this bit. In standard UART mode, the duration of the break is determined by how long software leaves this bit asserted. Also the duration of any required Stop bits following the break

must be timed by software before writing a new byte to be transmitted to the transmit data register. In LIN mode, the master sends a Break character by asserting *SBRK*. The duration of the break is timed by hardware, and the *SBRK* bit is deasserted by hardware when the Break is completed. The duration of the Break is determined by the *TxBreakLength* field of the LIN Control register. One or two stop bits are automatically provided by the hardware in LIN mode as defined by the *STOP* bit.

0 = No break is sent.

1 = The output of the transmitter is 0.

STOP—Stop Bit Select

0 = The transmitter sends one stop bit.

1 = The transmitter sends two stop bits.

LBEN—Loop Back Enable

0 = Normal operation.

1 = All transmitted data is looped back to the receiver within the IrDA module.

LIN-UART Control 1 Registers

Multiple registers (Table 72 through Table 74) are accessible by a single bus address. The register selected is determined by the Mode Select (MSEL) field. These registers provide additional control over LIN-UART operation.

Multiprocessor Control Register

When MSEL = 000b, the Multiprocessor Control register (Table 72) provides control for UART MULTIPROCESSOR mode, IRDA mode, baud rate timer mode as well as other features which applies to multiple modes.

Table 72. MultiProcessor Control Register (U0CTL1 with MSEL = 000b)

BITS	7	6	5	4	3	2	1	0
FIELD	MPMD[1]	MPEN	MPMD[0]	MPBT	DEPOL	BRGCTL	RDAIRQ	IREN
RESET	0	0	0	0	0	0	0	0
R/W	R/W	R/W	R/W	R/W	R/W	R/W	R/W	R/W
ADDR	F43H with MSEL = 000b							

MPMD[1:0]—MULTIPROCESSOR Mode

If MULTIPROCESSOR (9-bit) mode is enabled,

00 = The LIN-UART generates an interrupt request on all received bytes (data and address).

01 = The LIN-UART generates an interrupt request only on received address bytes.

10 = The LIN-UART generates an interrupt request when a received address byte matches

the value stored in the Address Compare register and on all successive data bytes until an address mismatch occurs.

11 = The LIN-UART generates an interrupt request on all received data bytes for which the most recent address byte matched the value in the Address Compare register.

MPEN—MULTIPROCESSOR (9-bit) Enable

This bit is used to enable MULTIPROCESSOR (9-bit) mode.

0 = Disable Multiprocessor (9-bit) mode.

1 = Enable Multiprocessor (9-bit) mode.

MPBT—Multiprocessor Bit Transmit

This bit is applicable only when Multiprocessor (9-bit) mode is enabled.

0 = Send 0 in the multiprocessor bit location of the data stream (9th bit).

1 = Send 1 in the multiprocessor bit location of the data stream (9th bit).

DEPOL—Driver Enable Polarity

0 = DE signal is Active High.

1 = DE signal is Active Low.

BRGCTL—Baud Rate Generator Control

This bit causes different LIN-UART behavior depending on whether the LIN-UART receiver is enabled ($REN = 1$ in the LIN-UART Control 0 register).

When the LIN-UART receiver is not enabled, this bit determines whether the Baud Rate Generator issues interrupts.

0 = BRG is disabled. Reads from the Baud Rate High and Low Byte registers return the BRG Reload Value

1 = BRG is enabled and counting. The Baud Rate Generator generates a receive interrupt when it counts down to 1. Reads from the Baud Rate High and Low Byte registers return the current BRG count value.

When the LIN-UART receiver is enabled, this bit allows reads from the Baud Rate registers to return the BRG count value instead of the Reload Value.

0 = Reads from the Baud Rate High and Low Byte registers return the BRG Reload Value.

1 = Reads from the Baud Rate High and Low Byte registers return the current BRG count value. Unlike the Timers, there is no mechanism to latch the High Byte when the Low Byte is read.

RDAIRQ—Receive Data Interrupt Enable

0 = Received data and receiver errors generates an interrupt request to Interrupt Controller.

1 = Received data does not generate an interrupt request to the Interrupt Controller. Only receiver errors generate an interrupt request.

IREN—Infrared Encoder/Decoder Enable

0 = Infrared Encoder/Decoder is disabled. LIN-UART operates normally.

1 = Infrared Encoder/Decoder is enabled. The LIN-UART transmits and receives data through the Infrared Encoder/Decoder.

Noise Filter Control Register

When MSEL = 001b, the Noise Filter Control register (Table 73) provides control for the digital noise filter.

Table 73. Noise Filter Control Register (U0CTL1 with MSEL = 001b)

BITS	7	6	5	4	3	2	1	0
FIELD	NFEN	NFCTL			Reserved			
RESET	0	0	0	0	0	0	0	0
R/W	R/W	R/W	R/W	R/W	R	R	R	R
ADDR	F43H with MSEL = 001b							

NFEN—Noise Filter Enable

0 = Noise filter is disabled.

1 = Noise filter is enabled. Receive data is preprocessed by the noise filter.

NFCTL—Noise Filter Control

This field controls the delay and noise rejection characteristics of the noise filter. The wider the counter the more delay that is introduced by the filter and the wider the noise event that is filtered.

000 = 4-bit up/down counter

001 = 5-bit up/down counter

010 = 6-bit up/down counter

011 = 7-bit up/down counter

100 = 8-bit up/down counter

101 = 9-bit up/down counter

110 = 10-bit up/down counter

111 = 11-bit up/down counter

LIN Control Register

When $MSEL = 010b$, the LIN Control register provides control for the LIN mode of operation.

Table 74. LIN Control Register (U0CTL1 with MSEL = 010b)

BITS	7	6	5	4	3	2	1	0
FIELD	LMST	LSLV	ABEN	ABIEN	LinState[1:0]		TxBreakLength	
RESET	0	0	0	0	0	0	0	0
R/W	R/W	R/W	R/W	R/W	R/W	R/W	R/W	R/W
ADDR	F43H with $MSEL = 010b$							

LMST—LIN Master Mode

0 = LIN Master Mode not selected

1 = LIN Master Mode selected (if $MPEN, PEN, LSLV = 0$)

LSLV—LIN Slave Mode

0 = LIN Slave Mode not selected

1 = LIN Slave Mode selected (if $MPEN, PEN, LMST = 0$)

ABEN—Autobaud Enable

0 = Autobaud not enabled

1 = Autobaud enabled if in LIN Slave mode.

ABIEN—Autobaud Interrupt Enable

0 = Interrupt following Autobaud does not occur

1 = Interrupt follows Autobaud, if in LIN Slave mode and $ABEN = 1$. When the Autobaud character is received, a receive interrupt is generated and the ATB bit is set in the Status 0 register. There is no receive data associated with this interrupt. The Baud Reload registers will be updated by hardware with the new bit period value.

LinState[1:0]—LIN State Machine

The LinState is controlled by both hardware and software. Software can force a state change at any time if necessary. In normal operation, software moves the state in and out of Sleep state. For a LIN Slave, software changes the state from Sleep to Wait for Break after which hardware cycles through the Wait for Break, Autobaud and Active states. Software changes the state from one of the active states to Sleep state if the LIN bus goes into Sleep mode. For a LIN Master, software changes the state from Sleep to Active where it remains until software sets it back to the Sleep state. After configuration software does not alter the LinState field during operation.

00 = Sleep State (either LMST or LSLV may be set)

01 = Wait for Break state (only valid for $LSLV = 1$)

10 = Autobaud state (only valid for LSLV = 1)
11 = Active state (either LMST or LSLV may be set)

TxBreakLength—Used in LIN mode by the master to control the duration of the transmitted Break.

00 = 13 bit times
01 = 14 bit times
10 = 15 bit times
11 = 16 bit times

LIN-UART Address Compare Register

The LIN-UART Address Compare register stores the multinode network address of the LIN-UART. When the MPMD[1] bit of the LIN-UART Control register 0 is set, all incoming address bytes are compared to the value stored in this Address Compare register. Receive interrupts and RDA assertions only occur in the event of a match. See [Table 75](#).

Table 75. LIN-UART Address Compare Register (U0ADDR)

BITS	7	6	5	4	3	2	1	0
FIELD	COMP_ADDR							
RESET	00H							
R/W	R/W							
ADDR	F45H							

COMP_ADDR—Compare Address

This 8-bit value is compared to the incoming address bytes.

LIN-UART Baud Rate High and Low Byte Registers

The LIN-UART Baud Rate High and Low Byte registers ([Table 76](#) and [Table 77](#)) combine to create a 16-bit baud rate divisor value (BRG[15:0]) which sets the data transmission rate (baud rate) of the LIN-UART.

Table 76. LIN-UART Baud Rate High Byte Register (U0BRH)

BITS	7	6	5	4	3	2	1	0
FIELD	BRH							
RESET	FFH							
R/W	R/W							
ADDR	F46H							

Table 77. LIN-UART Baud Rate Low Byte Register (U0BRL)

BITS	7	6	5	4	3	2	1	0
FIELD	BRL							
RESET	FFH							
R/W	R/W							
ADDR	F47H							

► **Note:** *The UART must be disabled when updating the Baud Rate registers because the high and low registers must be written independently.*

The LIN-UART data rate is calculated using the below equation for standard UART operation:

$$\text{UART Data Rate (bps)} = \frac{\text{System Clock Frequency (Hz)}}{16 \times \text{UART Baud Rate Divisor Value}}$$

The LIN-UART data rate is calculated using the below equation for LIN mode UART operation:

$$\text{UART Data Rate (bps)} = \frac{\text{System Clock Frequency (Hz)}}{\text{UART Baud Rate Divisor Value}}$$

For a given LIN-UART data rate, the integer baud rate divisor value is calculated using the following equation for standard UART operation:

$$\text{UART Baud Rate Divisor Value} = \text{Round}\left(\frac{\text{System Clock Frequency (Hz)}}{16 \times \text{UART Data Rate (bits/s)}}\right)$$

For a given LIN-UART data rate, the integer baud rate divisor value is calculated using the following equation for LIN mode UART operation:

$$\text{UART Baud Rate Divisor Value } s = \text{Round}\left(\frac{\text{System Clock Frequency (Hz)}}{\text{UART Data Rate (bits/s)}}\right)$$

The baud rate error relative to the appropriate baud rate is calculated using the following equation:

$$\text{UART Baud Rate Error (\%)} = 100 \times \left(\frac{\text{Actual Data Rate} - \text{Desired Data Rate}}{\text{Desired Data Rate}}\right)$$

For reliable communication, the LIN-UART baud rate error must never exceed 5 percent. [Table 78](#) through [Table 82](#) provide error data for popular baud rates and commonly-used crystal oscillator frequencies for normal UART modes of operation.

Table 78. LIN-UART Baud Rates, 20.0 MHz System Clock

Applicable Rate (kHz)	BRG Divisor (Decimal)	Actual Rate (kHz)	Error (%)	Applicable Rate (kHz)	BRG Divisor (Decimal)	Actual Rate (kHz)	Error (%)
1250.0	1	1250.0	0.00	9.60	130	9.62	0.16
625.0	2	625.0	0.00	4.80	260	4.81	0.16
250.0	5	250.0	0.00	2.40	521	2.399	-0.03
115.2	11	113.64	-1.19	1.20	1042	1.199	-0.03
57.6	22	56.82	-1.36	0.60	2083	0.60	0.02
38.4	33	37.88	-1.36	0.30	4167	0.299	-0.01
19.2	65	19.23	0.16				

Table 79. LIN-UART Baud Rates, 10.0 MHz System Clock

Applicable Rate (kHz)	BRG Divisor (Decimal)	Actual Rate (kHz)	Error (%)	Applicable Rate (kHz)	BRG Divisor (Decimal)	Actual Rate (kHz)	Error (%)
1250.0	N/A	N/A	N/A	9.60	65	9.62	0.16
625.0	1	625.0	0.00	4.80	130	4.81	0.16
250.0	3	208.33	-16.67	2.40	260	2.40	-0.03
115.2	5	125.0	8.51	1.20	521	1.20	-0.03
57.6	11	56.8	-1.36	0.60	1042	0.60	-0.03
38.4	16	39.1	1.73	0.30	2083	0.30	0.2
19.2	33	18.9	0.16				

Table 80. LIN-UART Baud Rates, 5.5296 MHz System Clock

Applicable Rate (kHz)	BRG Divisor (Decimal)	Actual Rate (kHz)	Error (%)	Applicable Rate (kHz)	BRG Divisor (Decimal)	Actual Rate (kHz)	Error (%)
1250.0	N/A	N/A	N/A	9.60	36	9.60	0.00
625.0	N/A	N/A	N/A	4.80	72	4.80	0.00
250.0	1	345.6	38.24	2.40	144	2.40	0.00
115.2	3	115.2	0.00	1.20	288	1.20	0.00
57.6	6	57.6	0.00	0.60	576	0.60	0.00
38.4	9	38.4	0.00	0.30	1152	0.30	0.00
19.2	18	19.2	0.00				

Table 81. LIN-UART Baud Rates, 3.579545 MHz System Clock

Applicable Rate (kHz)	BRG Divisor (Decimal)	Actual Rate (kHz)	Error (%)	Applicable Rate (kHz)	BRG Divisor (Decimal)	Actual Rate (kHz)	Error (%)
1250.0	N/A	N/A	N/A	9.60	23	9.73	1.32
625.0	N/A	N/A	N/A	4.80	47	4.76	-0.83
250.0	1	223.72	-10.51	2.40	93	2.41	0.23
115.2	2	111.9	-2.90	1.20	186	1.20	0.23

Table 81. LIN-UART Baud Rates, 3.579545 MHz System Clock (Continued)

Applicable Rate (kHz)	BRG Divisor (Decimal)	Actual Rate (kHz)	Error (%)	Applicable Rate (kHz)	BRG Divisor (Decimal)	Actual Rate (kHz)	Error (%)
57.6	4	55.9	-2.90	0.60	373	0.60	-0.04
38.4	6	37.3	-2.90	0.30	746	0.30	-0.04
19.2	12	18.6	-2.90				

Table 82. LIN-UART Baud Rates, 1.8432 MHz System Clock

Applicable Rate (kHz)	BRG Divisor (Decimal)	Actual Rate (kHz)	Error (%)	Applicable Rate (kHz)	BRG Divisor (Decimal)	Actual Rate (kHz)	Error (%)
1250.0	N/A	N/A	N/A	9.60	12	9.60	0.00
625.0	N/A	N/A	N/A	4.80	24	4.80	0.00
250.0	N/A	N/A	N/A	2.40	48	2.40	0.00
115.2	1	115.2	0.00	1.20	96	1.20	0.00
57.6	2	57.6	0.00	0.60	192	0.60	0.00
38.4	3	38.4	0.00	0.30	384	0.30	0.00
19.2	6	19.2	0.00				

Infrared Encoder/Decoder

The Z8FMC16100 Series Flash MCU contains two fully-functional, high-performance UART to Infrared Encoder/Decoders (endecs). Each infrared endec is integrated with an on-chip UART to allow easy communication between the Z8FMC16100 Series Flash MCU and IrDA Physical Layer Specification, Version 1.3-compliant infrared transceivers. Infrared communication provides secure, reliable, low-cost, point-to-point communication between PCs, PDAs, cell phones, printers and other infrared enabled devices.

Architecture

Figure 19 displays the architecture of the infrared endec.

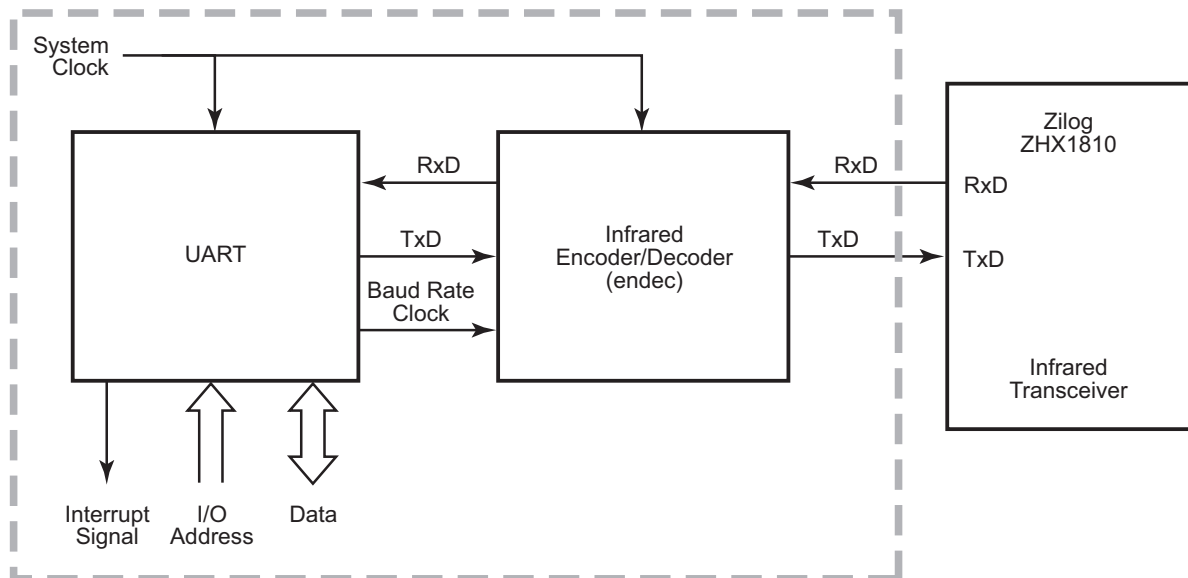

Figure 19. Infrared Data Communication System Block Diagram

Operation

When the infrared endec is enabled, the transmitted data from the associated on-chip UART is encoded as digital signals in accordance with IrDA standard and output to the infrared transceiver using the TXD pin. The data received from the infrared transceiver is passed to the infrared endec using the RXD pin, decoded by the infrared endec, and passed

to the UART. Communication is half-duplex, which means simultaneous data transmission and reception is not allowed.

The baud rate is set by the UART's Baud Rate Generator and supports IrDA standard baud rates from 9600 baud to 115.2 Kbaud. Higher baud rates are possible, but do not meet IrDA specifications. The UART must be enabled to use the infrared endec. The infrared endec data rate is calculated using the following equation:

$$\text{Infrared Data Rate (bps)} = \frac{\text{System Clock Frequency (Hz)}}{16 \times \text{UART Baud Rate Divisor Value}}$$

Transmitting IrDA Data

The data to be transmitted using the infrared transceiver is first sent to the UART. The UART's transmit signal (TXD) and baud rate clock are used by the IrDA to generate the modulation signal (IR_TXD) which drives the infrared transceiver. Each UART/Infrared data bit is 16-clocks wide. If the data to be transmitted is 1, the IR_TXD signal remains Low for the full 16-clock period. If the data to be transmitted is 0, a 3-clock high pulse is output following a 7-clock low period. After the 3-clock high pulse, a 6-clock low period is output to complete the full 16-clock data period. [Figure 20](#) displays the IrDA data transmission. When the infrared endec is enabled, the UART's TXD signal is internal to the Z8FMC16100 Series Flash MCU while the IR_TXD signal is output through the TXD pin.

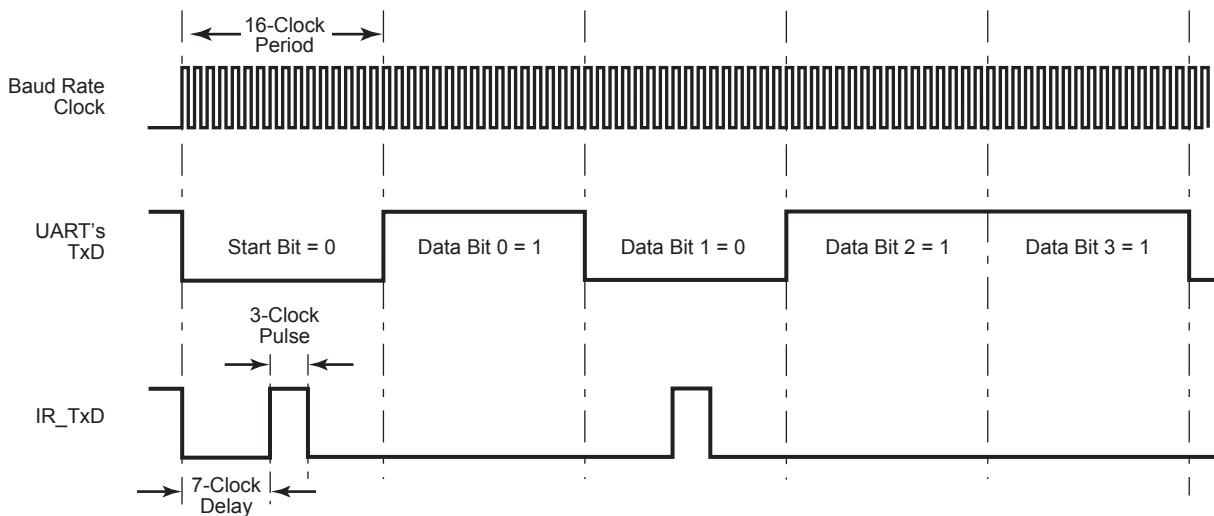

Figure 20. Infrared Data Transmission

Receiving IrDA Data

Data received from the infrared transceiver via the IR_RXD signal through the RXD pin is decoded by the infrared endec and passed to the UART. The UART's baud rate clock is used by the infrared endec to generate the demodulated signal (RXD) which drives the UART. Each UART/Infrared data bit is 16-clocks wide. Figure 21 displays the data reception. When the infrared endec is enabled, the UART's RXD signal is internal to the Z8FMC16100 Series Flash MCU while the IR_RXD signal is received through the RXD pin.

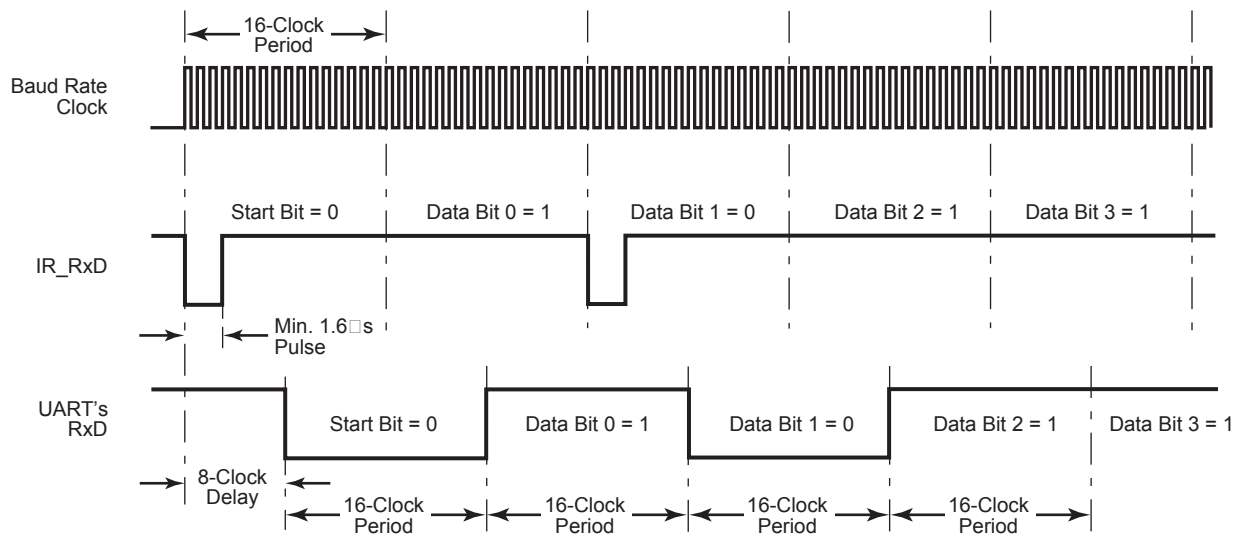

Figure 21. Infrared Data Reception



Caution: The system clock frequency must be at least 1.0 MHz to ensure proper reception of the 1.6 μs minimum-width pulses allowed by the IrDA standard.

Endec Receiver Synchronization

The IrDA receiver uses a local baud rate clock counter (0 to 15 clock periods) to generate an input stream for the UART and to create a sampling window for detection of incoming pulses. The generated UART input (UART RXD) is delayed by 8 baud rate clock periods with respect to the incoming IrDA data stream. When a falling edge in the input data stream is detected, the endec counter is reset. When the count reaches a value of 8, the UART RXD value is updated to reflect the value of the decoded data. When the count reaches 12 baud clock periods, the sampling window for the next incoming pulse opens. The window remains open until the count again reaches 8 (or in other words 24 baud clock periods since the previous pulse was detected) giving the endec a sampling window of minus four baud rate clocks to plus eight baud rate clocks around the expected time of an

incoming pulse. If an incoming pulse is detected inside this window this process is repeated. If the incoming data is a logical 1 (no pulse), the endec returns to the initial state and waits for next falling edge. As each falling edge is detected, the endec clock counter is reset, resynchronizing the endec to the incoming signal. This allows the endec to tolerate jitter and baud rate errors in the incoming data stream. Resynchronizing the endec does not alter the operation of the UART, that ultimately receives the data. The UART is only synchronized to the incoming data stream when a Start bit is received.

Infrared Encoder/Decoder Control Register Definitions

All infrared endec configuration and status information is set by the UART control registers as defined in [LIN-UART Control Register Definitions](#) on page 128.



Caution: *To prevent spurious signals during IrDA data transmission, set the IREN bit in the UARTx Control 1 register to 1 to enable the Infrared Encoder/Decoder before enabling the GPIO Port alternate function for the corresponding pin.*

Serial Peripheral Interface

The Serial Peripheral Interface (SPI) is a synchronous interface allowing several SPI-type devices, such as EEPROMs, to be interconnected. The SPI features include:

- Full-duplex, synchronous, character-oriented communication
- Four-wire interface
- Data transfer rates up to a maximum of one-half the system clock frequency
- Error detection
- Dedicated Baud Rate Generator

Architecture

The SPI can be configured as either a master (in single or multimaster systems) or a slave as displayed in [Figure 22](#), [Figure 23](#), and [Figure 24](#).

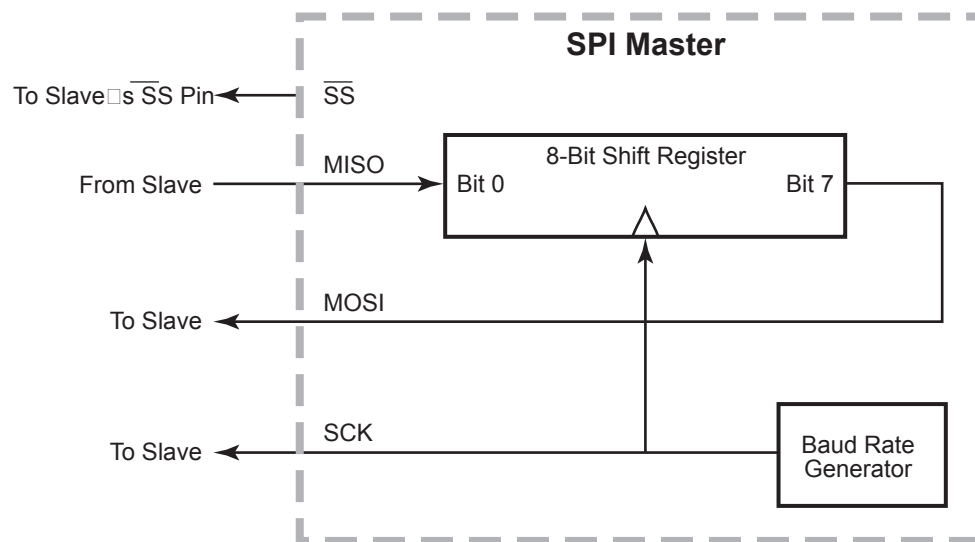

Figure 22. SPI Configured as a Master in a Single Master, Single Slave System

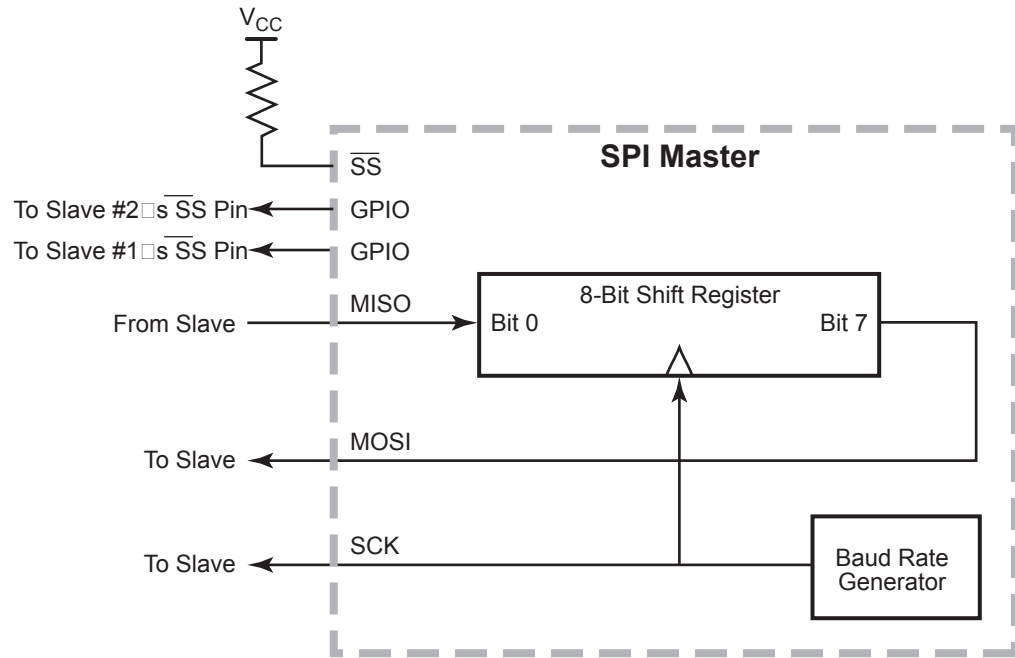

Figure 23. SPI Configured as a Master in a Single Master, Multiple Slave System

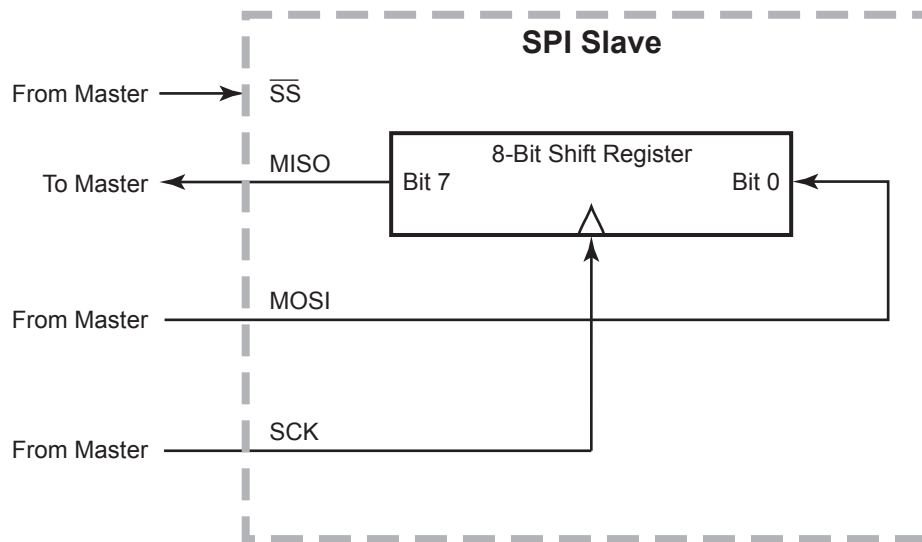

Figure 24. SPI Configured as a Slave

Operation

The SPI is a full-duplex, synchronous, character-oriented channel that supports a four-wire interface (serial clock, transmit, receive, and slave select). The SPI block consists of a transmit/receive shift register, a Baud Rate (clock) Generator, and a control unit.

During an SPI transfer, data is sent and received simultaneously by both the master and the slave SPI devices. Separate signals are required for data and the serial clock. When an SPI transfer occurs, a multibit (typically 8-bit) character is shifted out one data pin and an multibit character is simultaneously shifted in on a second data pin. An 8-bit shift register in the master and another 8-bit shift register in the slave are connected as a circular buffer. The SPI shift register is single-buffered in the transmit and receive directions. New data to be transmitted cannot be written into the shift register until the previous transmission is complete and receive data (if valid) has been read.

SPI Signals

The four basic SPI signals are:

- Master-In/Slave-Out (MISO)
- Master-Out/Slave-In (MOSI)
- Serial Clock (SCK)
- Slave Select (\overline{SS})

Each signal is described in both MASTER and SLAVE modes.

Master-In/Slave-Out

The Master-In/Slave-Out (MISO) pin is configured as an input in a master device and as an output in a slave device. It is one of the two lines that transfer serial data, with the most significant bit sent first. The MISO pin of a slave device is placed in a high-impedance state if the slave is not selected. When the SPI is not enabled, this signal is in a high-impedance state.

Master-Out/Slave-In

The Master-Out/Slave-In (MOSI) pin is configured as an output in a master device and as an input in a slave device. It is one of the two lines that transfer serial data, with the most significant bit sent first. When the SPI is not enabled, this signal is in a high-impedance state.

Serial Clock

The Serial Clock (SCK) synchronizes data movement both in and out of the device through its MOSI and MISO pins. In MASTER mode, the SPI's Baud Rate Generator creates the

serial clock. The master drives the serial clock through its own serial clock (SCK) pin to the slave's SCK pin. When the SPI is configured as a slave, the SCK pin is an input and the clock signal from the master synchronizes the data transfer between the master and slave devices. These slave devices ignore the SCK signal unless the \overline{SS} pin is asserted. When configured as a slave, the SPI block requires a minimum SCK period of greater than or equal to 8 times the system (X_{IN}) clock period.

The master and slave are each capable of exchanging a character of data during a sequence of `NUMBITS` clock cycles (refer to the `NUMBITS` field in the `SPIMODE` register). In both master and slave SPI devices, data is shifted on one edge of the SCK and is sampled on the opposite edge, where data is stable. Edge polarity is determined by the SPI phase and polarity control.

Slave Select

The active Low Slave Select (\overline{SS}) input signal selects a slave SPI device. \overline{SS} must be Low prior to all data communication to and from the slave device. \overline{SS} must remain Low for the full duration of each character transferred. The \overline{SS} signal may stay Low during the transfer of multiple characters, or may deassert between each character.

When the SPI is configured as the only master in an SPI system, the \overline{SS} pin can be set as either an input or an output. For communication between the Z8 Encore![®] 8K Series device's SPI master and external slave devices, the \overline{SS} signal, as an output, can assert the \overline{SS} input pin on one of the slave devices. Other GPIO output pins can also be employed to select external SPI slave devices.

When the SPI is configured as one master in a multimaster SPI system, the \overline{SS} pin should be set as an input. The \overline{SS} input signal on the master must be High. If the \overline{SS} signal goes Low (indicating that another master is driving the SPI bus), a collision error flag is set in the SPI Status register.

SPI Clock Phase and Polarity Control

The SPI supports four combinations of serial clock phase and polarity using two bits in the SPI Control register. The clock polarity bit, `CLKPOL`, selects an active High or active Low clock and has no effect on the transfer format. [Table 83](#) lists the SPI Clock Phase and Polarity Operation parameters. The clock phase bit, `PHASE`, selects one of two fundamentally different transfer formats. For proper data transmission, clock phase and polarity must be identical for the SPI master and the SPI slave. The master always places data on the MOSI line a half-cycle before the receive clock edge (SCK signal) for the slave to latch the data.

Table 83. SPI Clock Phase and Clock Polarity Operation

PHASE	CLKPOL	SCK Transmit Edge	SCK Receive Edge	SCK Idle State
0	0	Falling	Rising	Low
0	1	Rising	Falling	High
1	0	Rising	Falling	Low
1	1	Falling	Rising	High

Transfer Format Phase Equals Zero

Figure 25 displays the timing diagram for an SPI transfer in which PHASE is cleared to 0. The two SCK waveforms show polarity with CLKPOL reset to 0 and with CLKPOL set to 1. The diagram can be interpreted as either a master or slave timing diagram because the SCK Master-In/Slave-Out (MISO) and Master-Out/Slave-In (MOSI) pins are directly connected between the master and the slave.

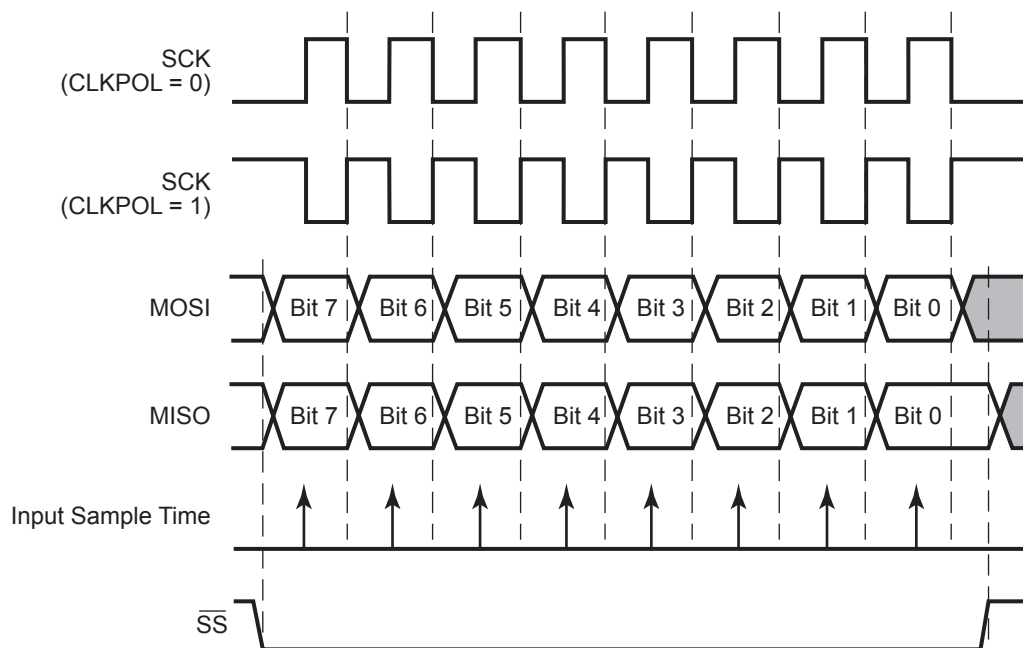

Figure 25. SPI Timing When Phase is 0

Transfer Format Phase Equals One

Figure 26 displays the timing diagram for an SPI transfer in which PHASE is 1. Two waveforms are depicted for SCK, one for CLKPOL reset to 0, and another for CLKPOL set to 1.

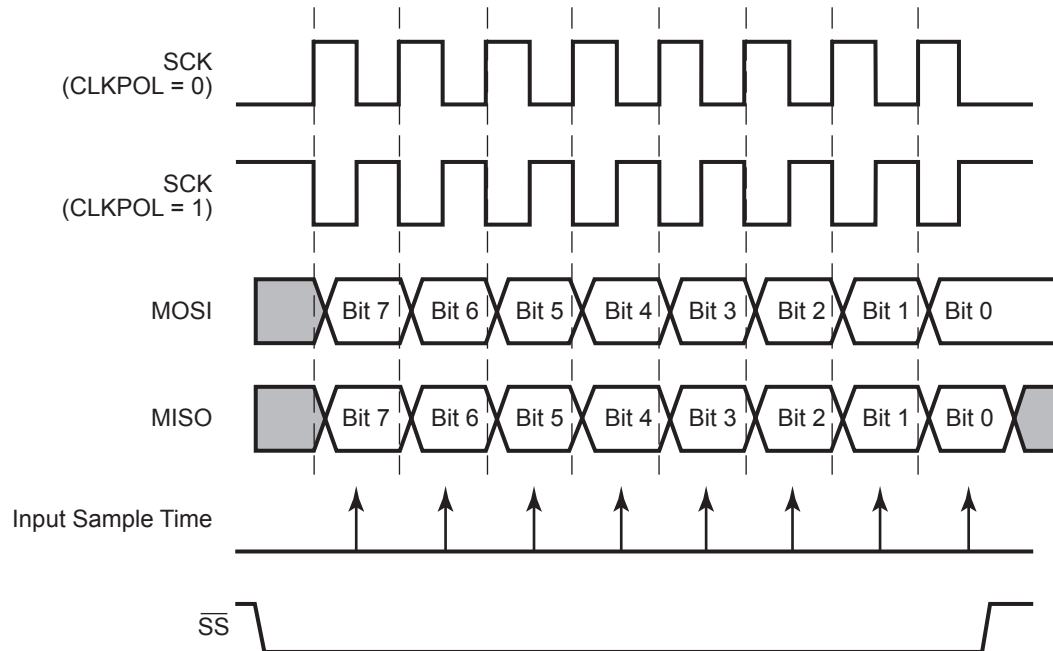

Figure 26. SPI Timing When Phase is 1

Multimaster Operation

In a multimaster SPI system, all SCK pins are tied together, all MOSI pins are tied together, and all MISO pins are tied together. All SPI pins must then be configured in OPEN-DRAIN mode to prevent bus contention. At any time, only one SPI device is configured as the master and all other SPI devices on the bus are configured as slaves. The master enables a single slave by asserting the \overline{SS} pin on that slave only. Then, the single master drives data out its SCK and MOSI pins to the SCK and MOSI pins on the slaves (including those which are not enabled). The enabled slave drives data out its MISO pin to the MISO master pin.

For a master device operating in a multimaster system, if the \overline{SS} pin is configured as an input and is driven Low by another master, the COL bit is set to 1 in the SPI Status register. The COL bit indicates the occurrence of a multimaster collision (mode fault error condition).

Slave Operation

The SPI block is configured for SLAVE mode operation by setting the SPIEN bit to 1 and the MMEN bit to 0 in the SPICTL register and setting the SSIO bit to 0 in the SPIMODE register. The IRQE, PHASE, CLKPOL, and WOR bits in the SPICTL register and the NUMBITS field in the SPIMODE register must be set to be consistent with the other SPI devices. The STR bit in the SPICTL register can be used, if appropriate, to force a *start-up* interrupt. The BIRQ bit in the SPICTL register and the SSV bit in the SPIMODE register are not used in SLAVE mode. The SPI baud rate generator is not used in SLAVE mode; therefore, the SPIBRH and SPIBRL registers do not require initialization.

If the slave contains data to send to the master, the data should be written to the SPIDAT register before the transaction starts (first edge of SCK when \overline{SS} is asserted). If the SPIDAT register is not written prior to the slave transaction, the MISO pin outputs the value that is currently in the SPIDAT register.

Due to the delay resulting from synchronization of the SPI input signals to the internal system clock, the maximum SPICLK baud rate that can be supported in SLAVE mode is the system clock frequency (X_{IN}) divided by 8. This rate is controlled by the SPI master.

Error Detection

The SPI contains error detection logic that supports SPI communication protocols and recognizes when communication errors have occurred. The SPI Status register indicates when a data transmission error has been detected.

Overrun

An overrun error (write collision) indicates that a Write to the SPI Data register was attempted while a data transfer is in progress (in either MASTER or SLAVE modes). An overrun sets the OVR bit in the SPI Status register to 1. Writing a 1 to OVR clears this error flag. The SPI Data register is not altered when a Write occurs while a data transfer is in progress.

Mode Fault

A mode fault indicates when more than one master is trying to communicate at the same time (a multimaster collision). The mode fault is detected when the enabled master's \overline{SS} pin is asserted. A mode fault sets the COL bit in the SPI Status register to 1. Writing a 1 to COL clears this error flag.

Slave Mode Abort

In the SLAVE mode, if the \overline{SS} pin deasserts before all bits in a character are transferred, the transaction aborts. When this condition occurs, the ABT bit is set in the SPISTAT register as well as the IRQ bit (which indicates that the transaction is complete).

The next time \overline{SS} asserts, the MISO pin outputs SPIDAT[7], regardless of where the previous transaction suspended. Writing a 1 to \overline{ABT} clears this error flag.

SPI Interrupts

When SPI interrupts are enabled, the SPI generates an interrupt after character transmission/reception is completed in both MASTER and SLAVE modes. A character can be defined to be 1–8 bits by the $\overline{NUMBITS}$ field in the SPI Mode register. In SLAVE mode, it is not necessary for \overline{SS} to deassert between characters to generate an interrupt. The SPI in SLAVE mode can also generate an interrupt if the \overline{SS} signal deasserts prior to transfer of all the bits in a character (see description of slave abort error above). Writing a 1 to the \overline{IRQ} bit in the SPI Status register clears the pending SPI interrupt request. The \overline{IRQ} bit must be cleared to 0 by the interrupt service routine to generate future interrupts. To start the transfer process, an SPI interrupt can be forced by software to write a 1 to the \overline{STR} bit in the SPICTL register.

If the SPI is disabled, an SPI interrupt can be generated by a Baud Rate Generator timeout. This timer function must be enabled by setting the \overline{BIRQ} bit in the SPICTL register. This Baud Rate Generator timeout does not set the \overline{IRQ} bit in the SPISTAT register, just the SPI interrupt bit in the interrupt controller.

SPI Baud Rate Generator

In SPI MASTER mode, the Baud Rate Generator creates a lower-frequency serial clock (SCK) for data transmission synchronization between the master and the external slave. The input to the Baud Rate Generator is from the system clock. The SPI Baud Rate High and Low Byte registers combine to form a 16-bit reload value, BRG[15:0], for the SPI Baud Rate Generator. The SPI baud rate is calculated using the following equation:

$$\text{SPI Baud Rate (bps)} = \frac{\text{System Clock Frequency (Hz)}}{2 \times \text{BRG}[15:0]}$$

Minimum baud rate is obtained by setting BRG[15:0] to 0000h for a clock divisor value of ($2 \times 65536 = 131072$).

When the SPI is disabled, the Baud Rate Generator can function as a basic 16-bit timer with an interrupt upon timeout. To configure the Baud Rate Generator as a timer with an interrupt upon timeout, complete the following procedure:

1. Disable the SPI by clearing the \overline{SPIEN} bit in the SPI Control register to 0.
2. Load the appropriate 16-bit count value into the SPI Baud Rate High and Low Byte registers.
3. Enable the Baud Rate Generator timer function and the associated interrupt by setting the \overline{BIRQ} bit in the SPI Control register to 1.

SPI Data Register

The SPI Data register stores both the outgoing (transmit) data and the incoming (receive) data. Reads from the SPI Data register always return the current contents of the 8-bit shift register. Data is shifted out starting with bit 7. The last bit received resides in bit position 0.

With the SPI configured as a master, writing a data byte to this register initiates data transmission. With the SPI configured as a slave, writing a data byte to this register loads the shift register in preparation for the next data transfer with the external master. In either MASTER or SLAVE mode, if a transmission is already in progress, Writes to this register are ignored and the overrun error flag, *OVR*, is set in the SPI Status register.

When character length is less than 8 bits (as set by the *NUMBITS* field in the SPI Mode register), the transmit character must be left-justified in the SPI Data register. A received character of less than 8 bits is right-justified (the final bit received is in bit position 0). For example, if the SPI is configured for 4-bit characters, the transmit characters must be written to *SPIDATA*[7:4] and the received characters are read from *SPIDATA*[3:0], see [Table 84](#).

Table 84. SPI Data Register (SPIDATA)

BITS	7	6	5	4	3	2	1	0
FIELD	DATA							
RESET	X							
R/W	R/W							
ADDR	F60H							

DATA—Data

Transmit and/or receive data.

SPI Control Register

The SPI Control register configures the SPI for transmit and receive operations.

Table 85. SPI Control Register (SPICTL)

BITS	7	6	5	4	3	2	1	0
FIELD	IRQE	STR	BIRQ	PHASE	CLKPOL	WOR	MMEN	SPIEN
RESET	00H							
R/W	R/W							
ADDR	F61H							

IRQE—Interrupt Request Enable

0 = SPI interrupts are disabled. No interrupt requests are sent to the Interrupt Controller.

1 = SPI interrupts are enabled. Interrupt requests are sent to the Interrupt Controller.

STR—Start an SPI Interrupt Request

0 = No effect.

1 = Setting this bit to 1 also sets the `IRQ` bit in the SPI Status register to 1. Setting this bit forces the SPI to send an interrupt request to the Interrupt Control. This bit can be used by software for a function similar to transmit buffer empty in a UART. Writing a 1 to the `IRQ` bit in the SPI Status register clears this bit to 0.

BIRQ—BRG Timer Interrupt Request

If the SPI is enabled, this bit has no effect. If the SPI is disabled:

0 = The Baud Rate Generator timer function is disabled.

1 = The Baud Rate Generator timer function and timeout interrupt are enabled.

PHASE—Phase Select

Sets the phase relationship of the data to the clock. For more details on operation of the `PHASE` bit, see SPI Clock Phase and Polarity Control section.

CLKPOL—Clock Polarity

0 = SCK idles Low (0).

1 = SCK idle High (1).

WOR—Wire-OR (Open-Drain) Mode Enabled

0 = SPI signal pins not configured for open-drain.

1 = All four SPI signal pins (`SCK`, $\overline{\text{SS}}$, `MISO`, `MOSI`) configured for open-drain function. This setting is typically used for multi-master and/or multi-slave configurations.

MMEN—SPI MASTER Mode Enable

0 = SPI configured in SLAVE mode.

1 = SPI configured in MASTER mode.

SPIEN—SPI Enable

0 = SPI disabled.

1 = SPI enabled.

SPI Status Register

The SPI Status register indicates the current state of the SPI. All bits revert to their reset state if the SPIEN bit in the SPICTL register = 0.

Table 86. SPI Status Register (SPISTAT)

BITS	7	6	5	4	3	2	1	0
FIELD	IRQ	OVR	COL	ABT	Reserved		TXST	SLAS
RESET	0	0	0	0	0	0	0	1
R/W	R/W*				R			
ADDR	F62H							
R/W* = Read access. Write a 1 to clear the bit to 0.								

IRQ—Interrupt Request

If SPIEN = 1, this bit is set if the STR bit in the SPICTL register is set, or upon completion of an SPI master or slave transaction. This bit does not set if SPIEN = 0 and the SPI Baud Rate Generator is used as a timer to generate the SPI interrupt.

0 = No SPI interrupt request pending.

1 = SPI interrupt request is pending.

OVR—Overrun

0 = An overrun error has not occurred.

1 = An overrun error has been detected.

COL—Collision

0 = A multi-master collision (mode fault) has not occurred.

1 = A multi-master collision (mode fault) has been detected.

ABT—SLAVE mode transaction abort

This bit is set if the SPI is configured in SLAVE mode, a transaction is occurring and \overline{SS} deasserts before all bits of a character have been transferred as defined by the NUMBITS field of the SPIMODE register. The IRQ bit also sets, indicating the transaction has completed.

0 = A SLAVE mode transaction abort has not occurred.

1 = A SLAVE mode transaction abort has been detected.

Reserved—Must be 0.

TXST—Transmit Status

0 = No data transmission currently in progress.

1 = Data transmission currently in progress.

SLAS—Slave Select

If SPI enabled as a Slave,

0 = \overline{SS} input pin is asserted (Low)

1 = \overline{SS} input is not asserted (High).

If SPI enabled as a Master, this bit is not applicable.

SPI Mode Register

The SPI Mode register configures the character bit width and the direction and value of the \overline{SS} pin.

Table 87. SPI Mode Register (SPIMODE)

BITS	7	6	5	4	3	2	1	0
FIELD	Reserved		DIAG	NUMBITS[2:0]			SSIO	SSV
RESET	00H							
R/W	R		R/W					
ADDR	F63H							

Reserved—Must be 0.

DIAG—Diagnostic Mode Control bit

This bit is for SPI diagnostics. Setting this bit allows the Baud Rate Generator value to be read using the SPIBRH and SPIBRL register locations.

0 = Reading SPIBRH, SPIBRL returns the value in the SPIBRH and SPIBRL registers

1 = Reading SPIBRH returns bits [15:8] of the SPI Baud Rate Generator; and reading SPIBRL returns bits [7:0] of the SPI Baud Rate Counter. The Baud Rate Counter High and Low byte values are not buffered.



Caution: *Exercise caution if reading the values while the BRG is counting.*

NUMBITS[2:0]—Number of Data Bits Per Character to Transfer

This field contains the number of bits to shift for each character transfer. Refer to the SPI Data register description for information on valid bit positions when the character length is less than 8-bits.

000 = 8 bits

001 = 1 bit

010 = 2 bits

011 = 3 bits

100 = 4 bits

101 = 5 bits

110 = 6 bits

111 = 7 bits

SSIO—Slave Select I/O

0 = \overline{SS} pin configured as an input.

1 = \overline{SS} pin configured as an output (MASTER mode only).

SSV—Slave Select Value

If SSIO = 1 and SPI configured as a Master:

0 = \overline{SS} pin driven Low (0).

1 = \overline{SS} pin driven High (1).

This bit has no effect if SSIO = 0 or SPI configured as a Slave

SPI Diagnostic State Register

The SPI Diagnostic State register provides observability of internal state. It is a read-only register used for SPI diagnostics. More detail about each bit follows the table.

Table 88. SPI Diagnostic State Register (SPIDST)

BITS	7	6	5	4	3	2	1	0
FIELD	SCKEN	TCKEN	SPISTATE					
RESET	00H							
R/W	R							
ADDR	F64H							

SCKEN - Shift Clock Enable

0 = The internal Shift Clock Enable signal is deasserted

1 = The internal Shift Clock Enable signal is asserted (shift register is updates on next system clock)

TCKEN - Transmit Clock Enable

0 = The internal Transmit Clock Enable signal is deasserted.

1 = The internal Transmit Clock Enable signal is asserted. When this is asserted the serial data out is updated on the next system clock (MOSI or MISO).

SPISTATE - SPI State Machine

Defines the current state of the internal SPI State Machine.

SPI Baud Rate High and Low Byte Registers

The SPI Baud Rate High and Low Byte registers combine to form a 16-bit reload value (BRG[15:0]) for the SPI Baud Rate Generator. The SPI baud rate is calculated using the following equation:

$$\text{SPI Baud Rate (bps)} = \frac{\text{System Clock Frequency (Hz)}}{2 \times \text{BRG}[15:0]}$$

Minimum baud rate is obtained by setting BRG[15:0] to 0000h for a clock divisor value of (2 X 65536 = 131072).

Table 89. SPI Baud Rate High Byte Register (SPIBRH)

BITS	7	6	5	4	3	2	1	0
FIELD	BRH							
RESET	FFH							
R/W	R/W							
ADDR	F66H							

BRH = SPI Baud Rate High Byte

Most significant byte (BRG[15:8]) of the SPI Baud Rate Generator's reload value.

Table 90. SPI Baud Rate Low Byte Register (SPIBRL)

BITS	7	6	5	4	3	2	1	0
FIELD	BRL							
RESET	FFH							
R/W	R/W							
ADDR	F67H							

BRL = SPI Baud Rate Low Byte

Least significant byte (BRG[7:0]) of the SPI Baud Rate Generator's reload value.

I²C Master/Slave Controller

The I²C Master/Slave Controller ensures that the Z8FMC16100 Series Flash MCU devices are bus-compatible with the I²C protocol. The I²C bus consists of the serial data signal (SDA) and a serial clock signal (SCL) bidirectional lines. The features of I²C controller include:

- Operates in MASTER/SLAVE or SLAVE ONLY modes.
- Supports arbitration in a multimaster environment (MASTER/SLAVE mode).
- Supports data rates up to 400 Kbps.
- 7-bit or 10-bit slave address recognition (interrupt only on address match).
- Optional general call address recognition.
- Optional digital filter on receive SDA, SCL lines.
- Optional interactive receive mode allows software interpretation of each received address and/or data byte before acknowledging.
- Unrestricted number of data bytes per transfer.
- Baud Rate Generator can be used as a general-purpose timer with an interrupt if the I²C controller is disabled.

Architecture

Figure 27 displays the architecture of the I²C controller.

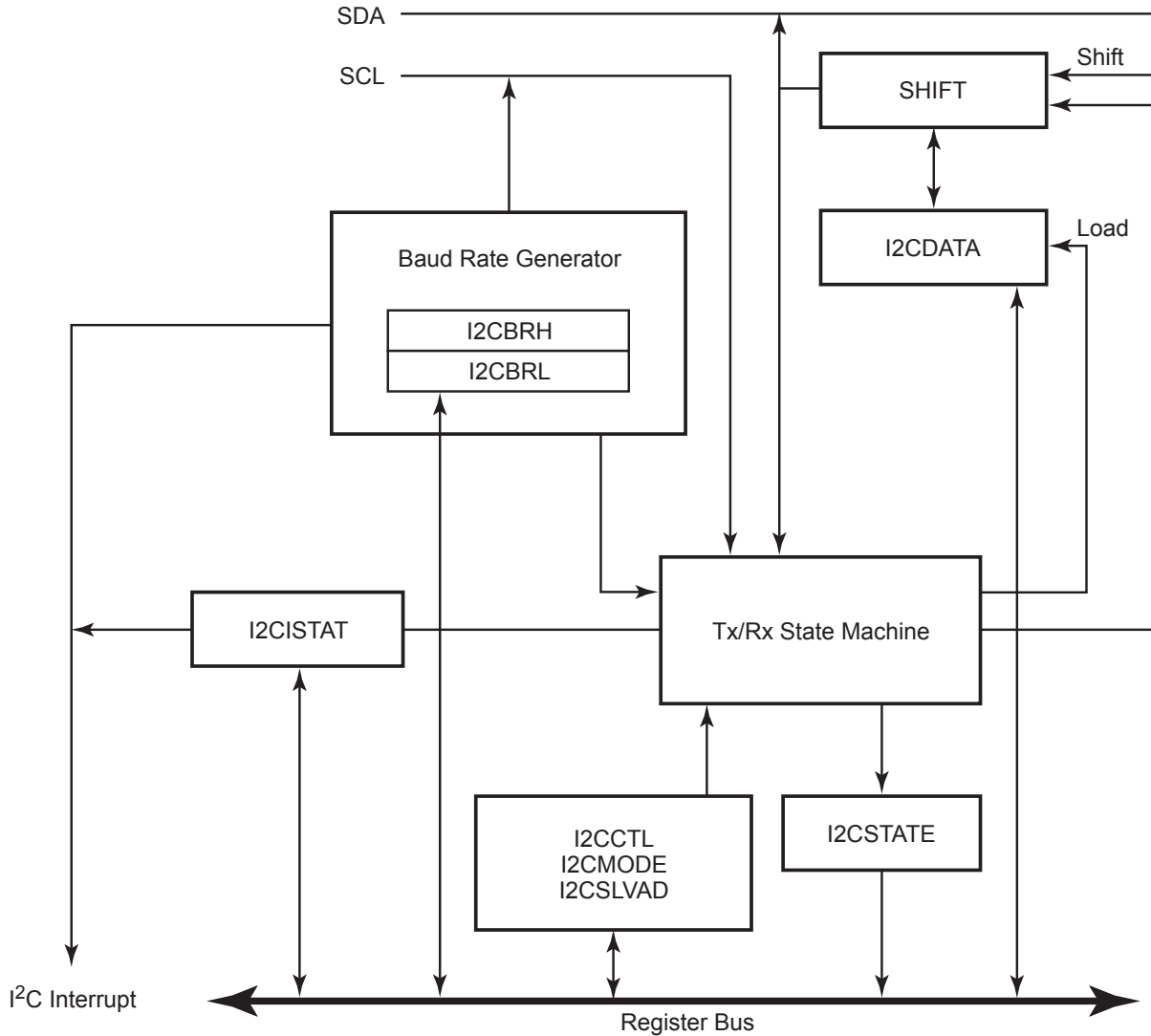

Figure 27. I²C Controller Block Diagram

I²C Master/Slave Controller Registers

Table 91 summarizes the I²C master/slave controller's software-accessible registers.

Table 91. I²C Master/Slave Controller Registers

Name	Abbreviation	Description
I ² C Data	I2CDATA	Transmit/receive Data Register.
I ² C Interrupt Status	I2CISTAT	Interrupt Status Register.
I ² C Control	I2CCTL	Control register—basic control functions.
I ² C Baud Rate High	I2CBRH	High byte of baud rate generator initialization value.
I ² C Baud Rate Low	I2CBRL	Low byte of baud rate generator initialization value.
I ² C State	I2CSTATE	State register.
I ² C Mode	I2CMODE	Selects MASTER or SLAVE modes, 7-bit or 10-bit addressing; configure address recognition, defines slave address bits [9:8].
I ² C Slave Address	I2CSLVAD	Defines slave address bits [7:0].

Comparison with the Master Mode Only I²C Controller

Porting code written for the MASTER ONLY I²C controller found on other Z8 Encore! parts to the I²C Master/Slave Controller is straightforward. The I2CDATA, I2CCTL, I2CBRH and I2CBRL register definitions have not changed. The following bullets highlight the differences between these two designs:

- The Status (I2CSTATE) register from the MASTER ONLY I²C controller is split into the Interrupt Status (I2CISTAT) register and the State (I2CSTATE) register because more interrupt sources are available. The ACK, 10B, TAS (now called AS), and DSS (now called DS) bits, formerly part of the Status register, are now part of the State register.
- The I2CSTATE register was called the Diagnostic State (I2CDST) register in the MASTER-mode-only version. The I2CDST register provided diagnostic information. The I2CSTATE register contains status and state information that may be useful to software in an operational mode.
- The I2CMODE register was called the Diagnostic Control (I2CDIAG) register in the MASTER-mode-only version. The I2CMODE register provides control for the SLAVE modes of operation, as well as the most significant two bits of the 10-bit slave address.
- The I2CSLVAD register is added to provide programming capabilities for the slave address.

- The ACKV bit in the I2CSTATE register enables the master to check the Acknowledge from the slave before sending the next byte.
- Support for multimaster environments—if arbitration is lost when operating as a master, the ARBLST bit in the I2CISTAT register is set and the mode automatically switches to SLAVE mode.

Operation

The I²C Master/Slave Controller operates in MASTER/SLAVE mode, SLAVE ONLY mode, or with master arbitration. In MASTER/SLAVE mode, it can be used as the only master on the bus or as one of several masters on the bus, with arbitration. In a multimaster environment, the controller switches from MASTER to SLAVE mode upon losing arbitration.

Though slave operation is fully supported in MASTER/SLAVE mode, if a device is intended to operate only as a slave, then SLAVE ONLY mode can be selected. In SLAVE ONLY mode, the device will not initiate a transaction, even if the software inadvertently sets the START bit.

SDA and SCL Signals

The I²C circuit sends all addresses, data, and acknowledges signals over the SDA line, most-significant bit first. SCL is the clock for the I²C bus. When the SDA and SCL pin alternate functions are selected for their respective GPIO ports, the pins are automatically configured for open-drain operation.

The master is responsible for driving the SCL clock signal. During Low period of the clock, a slave can hold the SCL signal Low to suspend the transaction if it is not ready to proceed. The master releases the clock at the end of the Low period and notices that the clock remains Low instead of returning to a High level. When the slave releases the clock, the I²C master continues transaction. All data is transferred in bytes; there is no limit to the amount of data transferred in one operation. When transmitting address, data, or an Acknowledge, the SDA signal changes in the middle of the Low period of SCL. When receiving address, Data or an Acknowledge, the SDA signal is sampled in the middle of the High period of SCL.

A low-pass digital filter can be applied to the SDA and SCL receive signals by setting the Filter Enable (FILTEN) bit in the I²C Control register. When the filter is enabled, any glitch less than a system clock period in width will be rejected. This filter should be enabled when running in I²C FAST mode (400 kbps), and can also be used at lower data rates.

I²C Interrupts

The I²C controller contains multiple interrupt sources that are combined into one interrupt request signal to the interrupt controller. If the I²C controller is enabled, the source of the interrupt is determined by which bits are set in the I2CISTAT register. If the I²C controller is disabled, the BRG controller can be used to generate general-purpose timer interrupts.

Each interrupt source, other than the baud rate generator interrupt, features an associated bit in the I2CISTAT register that clears automatically when software reads the register or performs another task, such as reading/writing the data register.

Transmit Interrupts

Transmit interrupts (TDRE bit = 1 in I2CISTAT) occur under the following conditions, both of which must be true:

- The transmit data register is empty and the TXI bit = 1 in the I²C Control register
- The I²C controller is enabled, with one of the following:
 - The first bit of a 10-bit address is shifted out
 - The first bit of the final byte of an address is shifted out and the RD bit is deasserted
 - The first bit of a data byte is shifted out

Writing to the I²C Data register always clears the TRDE bit to 0.

Receive Interrupts

Receive interrupts (RDRF bit = 1 in I2CISTAT) occur when a byte of data has been received by the I²C controller. The RDRF bit is cleared by reading from the I²C Data register. If the RDRF interrupt is not serviced prior to the completion of the next Receive byte, the I²C controller holds SCL Low during the final data bit of the next byte until RDRF is cleared, to prevent receive overruns. A receive interrupt does not occur when a slave receives an address byte or for data bytes following a slave address that did not match. An exception is if the Interactive Receive Mode (IRM) bit is set in the I2CMODE register, in which case Receive interrupts occur for all Receive address and data bytes in SLAVE mode.

Slave Address Match Interrupts

Slave address match interrupts (SAM bit = 1 in I2CISTAT) occur when the I²C controller is in SLAVE mode and an address is received that matches the unique slave address. The General Call Address (0000_0000) and STARTBYTE (0000_0001) are recognized if the GCE bit = 1 in the I2CMODE register. The software checks the RD bit in the I2CISTAT register to determine if the transaction is a Read or Write transaction. The General Call Address and STARTBYTE address are also distinguished by the RD bit. The General Call Address (GCA) bit of the I2CISTAT register indicates whether the address match occurred

on the unique slave address or the General Call/STARTBYTE address. The *SAM* bit clears automatically when the *I2CISTAT* register is read.

If configured through the *MODE* [1 : 0] field of the *I²C Mode* register for 7-bit slave addressing, the most significant 7 bits of the first byte of the transaction are compared against the *SLA* [6 : 0] bits of the *Slave Address* register. If configured for 10-bit slave addressing, the first byte of the transaction is compared against {11110, *SLA* [9 : 8], *R/W*} and the second byte is compared against *SLA* [7 : 0].

Arbitration Lost Interrupts

Arbitration Lost interrupts (*ARBLST* bit = 1 in *I2CISTAT*) occur when the *I²C* controller is in *MASTER* mode and loses arbitration (outputs a 1 on *SDA* and receives a 0 on *SDA*). The *I²C* controller switches to *SLAVE* mode when this instance occurs. This bit clears automatically when the *I2CISTAT* register is read.

Stop/Restart Interrupts

A Stop/Restart event interrupt (*SPRS* bit = 1 in *I2CISTAT*) occurs when the *I²C* controller is in *SLAVE* mode and a *STOP* or *RESTART* condition is received, indicating the end of the transaction. The *RSTR* bit in the *I2C State Register* indicates whether the bit was set due to a *STOP* or *RESTART* condition. When a restart occurs, a new transaction by the same master is expected to follow. This bit is cleared automatically when the *I2CISTAT* register is read. The *STOP/RESTART* interrupt only occurs on a selected (address match) slave.

Not Acknowledge Interrupts

Not Acknowledge interrupts (*NCKI* bit = 1 in *I2CISTAT*) occur in *MASTER* mode when a Not Acknowledge is received or sent by the *I²C* controller and the *START* or *STOP* bit is not set in the *I²C Control* register. In *MASTER* mode, the Not Acknowledge interrupt clears by setting the *START* or *STOP* bit. When this interrupt occurs in *MASTER* mode, the *I²C* controller waits until it is cleared before performing any action. In *SLAVE* mode, the Not Acknowledge interrupt occurs when a Not Acknowledge is received in response to data sent. The *NCKI* bit clears in *SLAVE* mode when software reads the *I2CISTAT* register.

General Purpose Timer Interrupt from Baud Rate Generator

If the *I²C* controller is disabled (*IEN* bit in the *I2CCTL* register = 0) and the *BIRQ* bit in the *I2CCTL* register = 1, an interrupt is generated when the baud rate generator (*BRG*) counts down to 1. The baud rate generator reloads and continues counting, providing a periodic interrupt. None of the bits in the *I2CISTAT* register are set, allowing the *BRG* in the *I²C* controller to be used as a general-purpose timer when the *I²C* controller is disabled.

Start and Stop Conditions

The master generates the START and STOP conditions to start or end a transaction. To start a transaction, the I²C controller generates a START condition by pulling the SDA signal Low while SCL is High. To complete a transaction, the I²C controller generates a STOP condition by creating a Low-to-High transition of the SDA signal while the SCL signal is High. These START and STOP events occur when the START and STOP bits in the I²C Control register are written by software to begin or end a transaction. Any byte transfer currently under way, including the Acknowledge phase, finishes before the START or STOP condition occurs.

Software Control of I²C Transactions

The I²C controller is configured via the I²C Control and I²C Mode registers. The MODE [1 : 0] field of the I²C Mode register allows the configuration of the I²C controller for MASTER/SLAVE or SLAVE ONLY mode, and configures the slave for 7- or 10-bit addressing recognition.

MASTER/SLAVE mode can be used for:

- MASTER ONLY operation in a *single master/one or more slave* I²C system
- MASTER/SLAVE in a *multimaster/multislave* I²C system
- SLAVE ONLY operation in an I²C system

In SLAVE ONLY mode, the START bit of the I²C Control register is ignored (software cannot initiate a master transaction by accident), and operation to SLAVE ONLY mode is restricted, thereby preventing accidental operation in MASTER mode.

The software can control I²C transactions by enabling the I²C controller interrupt in the interrupt controller or by polling the I²C Status register.

To use interrupts, the I²C interrupt must be enabled in the interrupt controller and followed by executing an EI instruction. The TXI bit in the I²C Control register must be set to enable transmit interrupts. An I²C interrupt service routine then checks the I²C Status register to determine the cause of the interrupt.

To control transactions by polling, the TDRE, RDRF, SAM, ARBLST, SPRS, and NCKI interrupt bits in the I²C Status register should be polled. The TDRE bit asserts regardless of the state of the TXI bit.

Master Transactions

The following sections describe master Read and Write transactions to both 7-bit and 10-bit slaves.

Master Arbitration

If a master loses arbitration during the address byte, it releases the SDA line, switches to SLAVE mode and monitors the address to determine if it is selected as a slave. If a master loses arbitration during the transmission of a data byte, it releases the SDA line and waits for the next STOP or START condition.

The master detects a loss of arbitration when a 1 is transmitted but a 0 is received from the bus in the same bit-time. This loss occurs if more than one master is simultaneously accessing the bus. Loss of arbitration can occur during the address phase (two or more masters accessing different slaves) or during the data phase, when the masters are attempting to write different data to the same slave.

When a master loses arbitration, the software is informed by means of the Arbitration Lost interrupt. The software can repeat the same transaction at a later time.

A special case can occur when a slave transaction starts just before the software attempts to start a new master transaction by setting the START bit. In this case, the state machine enters its slave states before the START bit is set, and as a result, the I²C controller will not arbitrate. If a slave address match occurs and the I²C controller receives/transmits data, the START bit is cleared and an Arbitration Lost interrupt is asserted. The software can minimize the chance of this instance occurring by checking the BUSY bit in the I2CSTATE register before initiating a master transaction. If a slave address match does not occur, the Arbitration Lost interrupt will not occur, and the START bit will not be cleared. The I²C controller will initiate the master transaction after the I²C bus is no longer busy.

Master Address-Only Transactions

It is sometimes preferable to perform an address-only transaction to determine if a particular slave device is able to respond. This transaction can be performed by monitoring the ACKV bit in the I2CSTATE register after the address has been written to the I2CDATA register and the START bit has been set. After the ACKV bit is set, the ACK bit in the I2CSTATE register determines if the slave is able to communicate. The STOP bit must be set in the I2CCTL register to terminate the transaction without transferring data. For a 10-bit slave address, if the first address byte is acknowledged, the second address byte should also be sent to determine if the preferred slave is responding.

Another approach is to set both the STOP and START bits (for sending a 7-bit address). After both bits have cleared (7-bit address has been sent and transaction is complete), the ACK bit can be read to determine if the slave has acknowledged. For a 10-bit slave, set the STOP bit after the second TDRE interrupt (which indicates that the second address byte is being sent).

Master Transaction Diagrams

In the following transaction diagrams, the shaded regions indicate the data that is transferred from the master to the slave, and the unshaded regions indicate the data that is transferred from the slave to the master.

The transaction field labels are defined as follows:

- S Start
- W Write
- A Acknowledge
- \bar{A} Not Acknowledge
- P Stop

Master Write Transaction with a 7-Bit Address

Figure 28 displays the data transfer format from a master to a 7-bit addressed slave.

S	Slave Address	W = 0	A	Data	A	Data	A	Data	\bar{A}	P/S
---	---------------	-------	---	------	---	------	---	------	-----------	-----

Figure 28. Data Transfer Format—Master Write Transaction with a 7-Bit Address

The procedure for a master transmit operation to a 7-bit addressed slave is as follows:

1. The software initializes the `MODE` field in the `I2C Mode` register for `MASTER/SLAVE` mode with either a 7- or 10-bit slave address. The `MODE` field selects the address width for this mode when addressed as a slave (but not for the remote slave). The software asserts the `IEN` bit in the `I2C Control` register.
2. The software asserts the `TXI` bit of the `I2C Control` register to enable transmit interrupts.
3. The `I2C` interrupt asserts, because the `I2C Data` register is empty.
4. The software responds to the `TDRE` bit by writing a 7-bit slave address plus the Write bit (which is cleared to 0) to the `I2C Data` register.
5. The software sets the `START` bit of the `I2C Control` register.
6. The `I2C` controller sends a `START` condition to the `I2C` slave.
7. The `I2C` controller loads the `I2C Shift` register with the contents of the `I2C Data` register.
8. After one bit of the address has been shifted out by the `SDA` signal, the transmit interrupt asserts.
9. The software responds by writing the transmit data into the `I2C Data` register.
10. The `I2C` controller shifts the remainder of the address and the Write bit out via the `SDA` signal.

11. The I²C slave sends an Acknowledge (by pulling the SDA signal Low) during the next High period of SCL. The I²C controller sets the ACK bit in the I²C Status register.
If the slave does not acknowledge the address byte, the I²C controller sets the NCKI bit in the I²C Status register, sets the ACKV bit, and clears the ACK bit in the I²C State register. The software responds to the Not Acknowledge interrupt by setting the STOP bit and clearing the TXI bit. The I²C controller flushes the Transmit Data register, sends a STOP condition on the bus, and clears the STOP and NCKI bits. The transaction is complete, and the following steps can be ignored.
12. The I²C controller loads the contents of the I²C Shift register with the contents of the I²C Data register.
13. The I²C controller shifts the data out via the SDA signal. After the first bit is sent, the transmit interrupt asserts.
14. If more bytes remain to be sent, return to Step 9.
15. When there is no more data to be sent, the software responds by setting the STOP bit of the I²C Control register (or the START bit to initiate a new transaction).
16. If no additional transaction is queued by the master, the software can clear the TXI bit of the I²C Control register.
17. The I²C controller completes transmission of the data on the SDA signal.
18. The I²C controller sends a STOP condition to the I²C bus.

► **Note:** *If the slave terminates the transaction early by responding with a Not Acknowledge during the transfer, the I²C controller asserts the NCKI interrupt and halts. The software must terminate the transaction by setting either the STOP bit (end transaction) or the START bit (end this transaction, start a new one). In this case, it is not necessary for software to set the FLUSH bit of the I2CCTL register to flush the data that was previously written but not transmitted. The I²C controller hardware automatically flushes transmit data in this not acknowledge case.*

Master Write Transaction with a 10-Bit Address

Figure 29 displays the data transfer format from a master to a 10-bit addressed slave.

S	Slave Address 1st Byte	W=0	A	Slave Address 2nd Byte	A	Data	A	Data	A \bar{A}	F/S
---	---------------------------	-----	---	---------------------------	---	------	---	------	-------------	-----

Figure 29. Data Transfer Format—Master Write Transaction with a 10-Bit Address

The first seven bits transmitted in the first byte are 11110XX. The two XX bits are the two most significant bits of the 10-bit address. The lowest bit of the first byte transferred is the

Read/Write control bit (which is cleared to 0). The transmit operation is performed in the same manner as 7-bit addressing.

The procedure for a master transmit operation to a 10-bit addressed slave is as follows:

1. The software initializes the `MODE` field in the I²C Mode register for MASTER/SLAVE mode with 7- or 10-bit addressing (the I²C bus protocol allows the mixing of slave address types). The `MODE` field selects the address width for this mode when addressed as a slave (but not for the remote slave). The software asserts the `IEN` bit in the I²C Control register.
2. The software asserts the `TXI` bit of the I²C Control register to enable transmit interrupts.
3. The I²C interrupt asserts because the I²C Data register is empty.
4. The software responds to the `TDRE` interrupt by writing the first slave address byte (11110xx0). The least-significant bit must be 0 for the write operation.
5. The software asserts the `START` bit of the I²C Control register.
6. The I²C controller sends a `START` condition to the I²C slave.
7. The I²C controller loads the I²C Shift register with the contents of the I²C Data register.
8. After one bit of the address is shifted out by the SDA signal, the transmit interrupt asserts.
9. The software responds by writing the second byte of address into the contents of the I²C Data register.
10. The I²C controller shifts the remainder of the first byte of the address and the Write bit out via the SDA signal.
11. The I²C slave sends an Acknowledge by pulling the SDA signal Low during the next High period of SCL. The I²C controller sets the `ACK` bit in the I²C Status register.
If the slave does not acknowledge the first address byte, the I²C controller sets the `NCKI` bit in the I²C Status register, sets the `ACKV` bit, and clears the `ACK` bit in the I²C State register. The software responds to the Not Acknowledge interrupt by setting the `STOP` bit and clearing the `TXI` bit. The I²C controller flushes the second address byte from the data register, sends a `STOP` condition on the bus, and clears the `STOP` and `NCKI` bits. The transaction is complete, and the following steps can be ignored.
12. The I²C controller loads the I²C Shift register with the contents of the I²C Data register (2nd address byte).
13. The I²C controller shifts the second address byte out via the SDA signal. After the first bit has been sent, the transmit interrupt asserts.
14. The software responds by writing the data to be written out to the I²C Control register.

15. The I²C controller shifts out the remainder of the second byte of the slave address (or ensuing data bytes, if looping) via the SDA signal.
16. The I²C slave sends an Acknowledge by pulling the SDA signal Low during the next High period of SCL. The I²C controller sets the ACK bit in the I²C Status register.
If the slave does not acknowledge, refer to the second paragraph of Step 11.
17. The I²C controller shifts the data out by the SDA signal. After the first bit is sent, the transmit interrupt asserts.
18. If more bytes remain to be sent, return to Step 14.
19. The software responds by asserting the STOP bit of the I²C Control register.
20. The I²C controller completes transmission of the data on the SDA signal.
21. The I²C controller sends a STOP condition to the I²C bus.

► **Note:** *If the slave responds with a Not Acknowledge during the transfer, the I²C controller asserts the NCKI bit, sets the ACKV bit, clears the ACK bit in the I²C State register, and halts. The software terminates the transaction by setting either the STOP bit (end transaction) or the START bit (end this transaction, start a new one). The Transmit Data register is flushed automatically.*

Master Read Transaction with a 7-Bit Address

Figure 30 displays the data transfer format for a read operation to a 7-bit addressed slave.

S	Slave Address	R = 1	A	Data	A	Data	A	P/S
---	---------------	-------	---	------	---	------	---	-----

Figure 30. Data Transfer Format—Master Read Transaction with a 7-Bit Address

The procedure for a master Read operation to a 7-bit addressed slave is as follows:

1. The software initializes the MODE field in the I²C Mode register for MASTER/SLAVE mode with 7- or 10-bit addressing (the I²C bus protocol allows the mixing of slave address types). The MODE field selects the address width for this mode when addressed as a slave (but not for the remote slave). The software asserts the IEN bit in the I²C Control register.
2. The software writes the I²C Data register with a 7-bit slave address, plus the Read bit (which is set to 1).
3. The software asserts the START bit of the I²C Control register.
4. If this operation is a single-byte transfer, the software asserts the NAK bit of the I²C Control register so that after the first byte of data has been read by the I²C controller, a Not Acknowledge instruction is sent to the I²C slave.

5. The I²C controller sends a *START* condition.
6. The I²C controller sends the address and Read bit out via the SDA signal.
7. The I²C slave acknowledges the address by pulling the SDA signal Low during the next High period of SCL.

If the slave does not acknowledge the address byte, the I²C controller sets the *NCKI* bit in the I²C Status register, sets the *ACKV* bit, and clears the *ACK* bit in the I²C State register. The software responds to the Not Acknowledge interrupt by setting the *STOP* bit and clearing the *TXI* bit. The I²C controller flushes the Transmit Data register, sends a *STOP* condition on the bus, and clears the *STOP* and *NCKI* bits. The transaction is complete, and the following steps can be ignored.

8. The I²C controller shifts in the first byte of data from the I²C slave on the SDA signal.
9. The I²C controller asserts the receive interrupt.
10. The software responds by reading the I²C Data register. If the next data byte is to be the final byte, the software must set the *NAK* bit of the I²C Control register.
11. The I²C controller sends a Not Acknowledge to the I²C slave if the next byte is the final byte; otherwise, it sends an Acknowledge.
12. If there are more bytes to transfer, the I²C controller returns to Step 7.
13. A NAK interrupt (*NCKI* bit in *I2CISTAT*) is generated by the I²C controller.
14. The software responds by setting the *STOP* bit of the I²C Control register.
15. A *STOP* condition is sent to the I²C slave.

Master Read Transaction with a 10-Bit Address

Figure 31 displays the read transaction format for a 10-bit addressed slave.

S	Slave Address 1st Byte	W=0	A	Slave Address 2nd Byte	A	S	Slave Address 1st Byte	R=1	A	Data	A	Data	A	P
---	---------------------------	-----	---	---------------------------	---	---	---------------------------	-----	---	------	---	------	---	---

Figure 31. Data Transfer Format—Master Read Transaction with a 10-Bit Address

The first seven bits transmitted in the first byte are 11110XX. The two XX bits are the two most-significant bits of the 10-bit address. The lowest bit of the first byte transferred is the write control bit.

The data transfer procedure for a Read operation to a 10-bit addressed slave is as follows:

1. The software initializes the *MODE* field in the I²C Mode register for MASTER/SLAVE mode with 7- or 10-bit addressing (the I²C bus protocol allows the mixing of slave address types). The *MODE* field selects the address width for this mode when addressed

as a slave (but not for the remote slave). The software asserts the IEN bit in the I²C Control register.

2. The software writes 11110b, followed by the two most-significant address bits and a 0 (write) to the I²C Data register.
3. The software asserts the START bit of the I²C Control register.
4. The I²C controller sends a START condition.
5. The I²C controller loads the I²C Shift register with the contents of the I²C Data register.
6. After the first bit has been shifted out, a transmit interrupt is asserted.
7. The software responds by writing the least significant eight bits of address to the I²C Data register.
8. The I²C controller completes shifting of the first address byte.
9. The I²C slave sends an Acknowledge by pulling the SDA signal Low during the next High period of SCL.

If the slave does not acknowledge the address byte, the I²C controller sets the NCKI bit in the I²C Status register, sets the ACKV bit and clears the ACK bit in the I²C State register. The software responds to the Not Acknowledge interrupt by setting the STOP bit and clearing the TXI bit. The I²C controller flushes the Transmit Data register, sends the STOP condition on the bus and clears the STOP and NCKI bits. The transaction is complete, and the following steps can be ignored.

10. The I²C controller loads the I²C Shift register with the contents of the I²C Data register (the lower byte of the 10-bit address).
11. The I²C controller shifts out the next eight bits of the address. After the first bit shifts, the I²C controller generates a transmit interrupt.
12. The software responds by setting the START bit of the I²C Control register to generate a repeated START condition.
13. The software writes 11110b, followed by the 2-bit slave address and a 1 (Read) to the I²C Data register.
14. To read only one byte, the software responds by setting the NAK bit of the I²C Control register.
15. After the I²C controller shifts out the address bits listed in Step 9 (the second address transfer), the I²C slave sends an Acknowledge by pulling the SDA signal Low during the next High period of SCL.

If the slave does not acknowledge the address byte, the I²C controller sets the NCKI bit in the I²C Status register, sets the ACKV bit, and clears the ACK bit in the I²C State register. The software responds to the Not Acknowledge interrupt by setting the STOP bit and clearing the TXI bit. The I²C controller flushes the Transmit Data register,

sends the STOP condition on the bus, and clears the STOP and NCKI bits. The transaction is complete, and the following steps can be ignored.

16. The I²C controller sends a repeated START condition.
17. The I²C controller loads the I²C Shift register with the contents of the I²C Data register (the third address transfer).
18. The I²C controller sends 11110b, followed by the two most-significant bits of the slave read address and a 1 (Read).
19. The I²C slave sends an Acknowledge by pulling the SDA signal Low during the next High period of SCL.
20. The I²C controller shifts in a byte of data from the slave.
21. The I²C controller asserts the Receive interrupt.
22. The software responds by reading the I²C Data register. If the next data byte is to be the final byte, the software must set the NAK bit of the I²C Control register.
23. The I²C controller sends an Acknowledge or Not Acknowledge to the I²C slave, based on the value of the NAK bit.
24. If there are more bytes to transfer, the I²C controller returns to Step 18.
25. The I²C controller generates a NAK interrupt (the NCKI bit in the I2CISTAT register).
26. The software responds by setting the STOP bit of the I²C Control register.
27. A STOP condition is sent to the I²C slave.

Slave Transactions

The following sections describe Read and Write transactions to the I²C controller configured for 7-bit and 10-bit slave modes.

Slave Address Recognition

The following slave address recognition options are supported.

Slave 7-Bit Address Recognition Mode—If $IRM = 0$ during the address phase and the controller is configured for MASTER/SLAVE or SLAVE 7-bit address mode, the hardware detects a match to the 7-bit slave address defined in the I2CSLVAD register and generates the slave address match interrupt (the SAM bit = 1 in the I2CISTAT register). The I²C controller automatically responds during the Acknowledge phase with the value in the NAK bit of the I2CCTL register.

Slave 10-Bit Address Recognition Mode—If $IRM = 0$ during the address phase and the controller is configured for MASTER/SLAVE or SLAVE 10-bit address mode, the hardware detects a match to the 10-bit slave address defined in the I2CMODE and I2CSLVAD registers and generates the slave address match interrupt (the SAM bit = 1 in the I2CISTAT

register). The I²C controller automatically responds during the Acknowledge phase with the value in the NAK bit of the I2CCTL register.

General Call and Start Byte Address Recognition—If GCE = 1 and IRM = 0 during the address phase, and the controller is configured for MASTER/SLAVE or SLAVE in either 7- or 10-bit address modes, the hardware detects a match to the General Call Address or the START byte and generates the slave address match interrupt. A General Call Address is a 7-bit address of all 0's with the R/W bit = 0. A START byte is a 7-bit address of all 0's with the R/W bit = 1. The SAM and GCA bits are set in the I2CISTAT register. The RD bit in the I2CISTAT register distinguishes a General Call Address from a START byte which is cleared to 0 for a General Call Address).

For a General Call Address, the I²C controller automatically responds during the address acknowledge phase with the value in the NAK bit of the I2CCTL register. If the software is set to process the data bytes associated with the GCA bit, the IRM bit can optionally be set following the SAM interrupt to allow the software to examine each received data byte before deciding to set or clear the NAK bit.

A START byte will not be acknowledged—a requirement of the I²C specification.

Software Address Recognition—To disable hardware address recognition, the IRM bit must be set to 1 prior to the reception of the address byte(s). When IRM = 1, each received byte generates a receive interrupt (RDRF = 1 in the I2CISTAT register). The software must examine each byte and determine whether to set or clear the NAK bit. The slave holds SCL Low during the Acknowledge phase until the software responds by writing to the I2CCTL register. The value written to the NAK bit is used by the controller to drive the I²C bus, then releasing the SCL. The SAM and GCA bits are not set when IRM = 1 during the address phase, but the RD bit is updated based on the first address byte.

Slave Transaction Diagrams

In the following transaction diagrams, the shaded regions indicate data transferred from the master to the slave, and the unshaded regions indicate the data transferred from the slave to the master. The transaction field labels are defined as follows:

- S Start
- W Write
- A Acknowledge
- \bar{A} Not Acknowledge
- P Stop

Slave Receive Transaction with 7-Bit Address

The data transfer format for writing data from a master to a slave in 7-bit address mode is shown in Figure 32. The procedure that follows describes the I²C Master/Slave Controller operating as a slave in 7-bit addressing mode and receiving data from the bus master.

S	Slave Address	W=0	A	Data	A	Data	A	Data	A/ \bar{A}	P/S
---	---------------	-----	---	------	---	------	---	------	--------------	-----

Figure 32. Data Transfer Format—Slave Receive Transaction with 7-Bit Address

- The software configures the controller for operation as a slave in 7-bit addressing mode, as follows:
 - Initialize the `MODE` field in the I²C Mode register for either SLAVE ONLY mode or MASTER/SLAVE mode with 7-bit addressing.
 - Optionally set the `GCE` bit.
 - Initialize the `SLA[6:0]` bits in the I²C Slave Address register.
 - Set `IEN = 1` in the I²C Control register. Set `NAK = 0` in the I²C Control register.
- The bus master initiates a transfer, sending the address byte. In SLAVE mode, the I²C controller recognizes its own address and detects that the `R/ \bar{W}` bit = 0 (written from the master to the slave). The I²C controller acknowledges, indicating it is available to accept the transaction. The `SAM` bit in the `I2CISTAT` register is set to 1, causing an interrupt. The `RD` bit in the `I2CISTAT` register is cleared to 0, indicating a Write to the slave. The I²C controller holds the `SCL` signal Low, waiting for the software to load the first data byte.
- The software responds to the interrupt by reading the `I2CISTAT` register (which clears the `SAM` bit). After seeing the `SAM` bit to 1, the software checks the `RD` bit. Because `RD = 0`, no immediate action is required until the first byte of data is received. If software is only able to accept a single byte it sets the `NAK` bit in the `I2CCTL` register at this time.
- The master detects the Acknowledge and sends the byte of data.
- The I²C controller receives the data byte and responds with Acknowledge or Not Acknowledge depending on the state of the `NAK` bit in the `I2CCTL` register. The I²C controller generates the receive data interrupt by setting the `RDRF` bit in the `I2CISTAT` register.
- The software responds by reading the `I2CISTAT` register, finding the `RDRF` bit = 1 and reading the `I2CDATA` register clearing the `RDRF` bit. If software can accept only one more data byte it sets the `NAK` bit in the `I2CCTL` register.
- The master and slave loops through steps 4 to 6 until the master detects a Not Acknowledge instruction or runs out of data to send.

8. The master sends the STOP or RESTART signal on the bus. Either of these signals can cause the I²C controller to assert a STOP interrupt (the STOP bit = 1 in the I2CISTAT register). Because the slave received data from the master, the software takes no action in response to the STOP interrupt other than reading the I2CISTAT register to clear the STOP bit in the I2CISTAT register.

Slave Receive Transaction with 10-Bit Address

The data transfer format for writing data from a master to a slave with 10-bit addressing is shown in Figure 33. The procedure that follows describes the I²C Master/Slave Controller operating as a slave in 10-bit addressing mode and receiving data from the bus master.

S	Slave Address 1st Byte	W=0	A	Slave Address 2nd Byte	A	Data	A	Data	A \bar{A}	P/S
---	---------------------------	-----	---	---------------------------	---	------	---	------	-------------	-----

Figure 33. Data Transfer Format—Slave Receive Transaction with 10-Bit Address

1. The software configures the controller for operation as a slave in 10-bit addressing mode, as follows:
 - (a) Initialize the MODE field in the I2CMODE register for either SLAVE ONLY mode or MASTER/SLAVE mode with 10-bit addressing.
 - (b) Optionally set the GCE bit.
 - (c) Initialize the SLA [7 : 0] bits in the I2CSLVAD register and the SLA [9 : 8] bits in the I2CMODE register.
 - (d) Set IEN = 1 in the I2CCTL register. Set NAK = 0 in the I²C Control register.
2. The master initiates a transfer, sending the first address byte. The I²C controller recognizes the start of a 10-bit address with a match to SLA [9 : 8] and detects the R \bar{W} bit = 0 (a Write from the master to the slave). The I²C controller acknowledges, indicating it is available to accept the transaction.
3. The master sends the second address byte. The SLAVE mode I²C controller detects an address match between the second address byte and SLA [7 : 0]. The SAM bit in the I2CISTAT register is set to 1, thereby causing an interrupt. The RD bit is cleared to 0, indicating a Write to the slave. The I²C controller acknowledges, indicating it is available to accept the data.
4. The software responds to the interrupt by reading the I2CISTAT register, which clears the SAM bit. Because RD = 0, no immediate action is taken by the software until the first byte of data is received. If the software is only able to accept a single byte, it sets the NAK bit in the I2CCTL register.
5. The master detects the Acknowledge and sends the first byte of data.

6. The I²C controller receives the first byte and responds with Acknowledge or Not Acknowledge, depending on the state of the NAK bit in the I2CCTL register. The I²C controller generates the receive data interrupt by setting the RDRF bit in the I2CISTAT register.
7. The software responds by reading the I2CISTAT register, finding the RDRF bit = 1, and then reading the I2CDATA register, which clears the RDRF bit. If the software can accept only one more data byte, it sets the NAK bit in the I2CCTL register.
8. The master and slave loops through steps 5 to 7 until the master detects a Not Acknowledge instruction or runs out of data to send.
9. The master sends the STOP or RESTART signal on the bus. Either of these signals can cause the I²C controller to assert the STOP interrupt (the STOP bit = 1 in the I2CISTAT register). Because the slave received data from the master, the software takes no action in response to the STOP interrupt other than reading the I2CISTAT register to clear the STOP bit.

Slave Transmit Transaction with 7-bit Address

The data transfer format for a master reading data from a slave in 7-bit address mode is shown in Figure 37. The procedure that follows describes the I²C Master/Slave Controller operating as a slave in 7-bit addressing mode and transmitting data to the bus master.

S	Slave Address	R = 1	A	Data	A	Data	A	P/S
---	---------------	-------	---	------	---	------	---	-----

Figure 34. Data Transfer Format—Slave Transmit Transaction with 7-bit Address

1. The software configures the controller for operation as a slave in 7-bit addressing mode, as follows:
 - (a) Initialize the MODE field in the I²C Mode register for either SLAVE ONLY mode or MASTER/SLAVE mode with 7-bit addressing.
 - (b) Optionally set the GCE bit.
 - (c) Initialize the SLA[6:0] bits in the I²C Slave Address register.
 - (d) Set IEN = 1 in the I²C Control register. Set NAK = 0 in the I²C Control register.
2. The master initiates a transfer, sending the address byte. The SLAVE mode I²C controller finds an address match and detects that the R/W bit = 1 (read by the master from the slave). The I²C controller acknowledges, indicating that it is ready to accept the transaction. The SAM bit in the I2CISTAT register is set to 1, causing an interrupt. The RD bit is set to 1, indicating a Read from the slave.
3. The software responds to the interrupt by reading the I2CISTAT register, thereby clearing the SAM bit. Because RD = 1, the software responds by loading the first data byte into the I2CDATA register. The software sets the TXI bit in the I2CCTL register

to enable transmit interrupts. When the master initiates the data transfer, the I²C controller holds SCL Low until the software has written the first data byte to the I2CDATA register.

4. SCL is released and the first data byte is shifted out.
5. After the first bit of the first data byte has been transferred, the I²C controller sets the TDRE bit, which asserts the transmit data interrupt.
6. The software responds to the transmit data interrupt (TDRE = 1) by loading the next data byte into the I2CDATA register, which clears TDRE.
7. After the data byte has been received by the master, the master transmits an Acknowledge instruction (or Not Acknowledge instruction if this byte is the final data byte).
8. The bus cycles through steps 5 to 7 until the final byte has been transferred. If the software has not yet loaded the next data byte when the master brings SCL Low to transfer the most significant data bit, the slave I²C controller holds SCL Low until the data register has been written. When a Not Acknowledge instruction is received by the slave, the I²C controller sets the NCKI bit in the I2CISTAT register, causing the Not Acknowledge interrupt to be generated.
9. The software responds to the Not Acknowledge interrupt by clearing the TXI bit in the I2CCTL register and by asserting the FLUSH bit of the I2CCTL register to *empty* the data register.
10. When the master has completed the final acknowledge cycle, it asserts a STOP or RESTART condition on the bus.
11. The slave I²C controller asserts the STOP/RESTART interrupt (set SPRS bit in I2CISTAT register).
12. The software responds to the STOP/RESTART interrupt by reading the I2CISTAT register, which clears the SPRS bit.

Slave Transmit Transaction with 10-Bit Address

The data transfer format for a master reading data from a slave with 10-bit addressing is shown in Figure 35. The following procedure describes the I²C Master/Slave Controller operating as a slave in 10-bit addressing mode, transmitting data to the bus master.

S	Slave Address 1st Byte	W = 0	A	Slave Address 2nd Byte	A	S	Slave Address 1st Byte	R = 1	A	Data	A	Data	A	P
---	---------------------------	-------	---	---------------------------	---	---	---------------------------	-------	---	------	---	------	---	---

Figure 35. Data Transfer Format—Slave Transmit Transaction with 10-Bit Address

1. The software configures the controller for operation as a slave in 10-bit addressing mode:
 - (a) Initialize the `MODE` field in the I²C Mode register for either SLAVE ONLY mode or MASTER/SLAVE mode with 10-bit addressing.
 - (b) Optionally set the `GCE` bit.
 - (c) Initialize the `SLA [7 : 0]` bits in the I2CSLVAD register and `SLA [9 : 8]` in the I2CMODE register.
 - (d) Set `IEN = 1`, `NAK = 0` in the I²C Control register.
2. The master initiates a transfer, sending the first address byte. The SLAVE mode I²C controller recognizes the start of a 10-bit address with a match to `SLA [9 : 8]` and detects the `R/W` bit = 0 (a Write from the master to the slave). The I²C controller acknowledges, indicating it is available to accept the transaction.
3. The master sends the second address byte. The SLAVE mode I²C controller compares the second address byte with the value in `SLA [7 : 0]`. If there is a match, the `SAM` bit in the I2CISTAT register is set = 1, causing a slave address match interrupt. The `RD` bit is set = 0, indicating a write to the slave. If a match occurs, the I²C controller acknowledges on the I²C bus, indicating it is available to accept the data.
4. The software responds to the slave address match interrupt by reading the I2CISTAT register, which clears the `SAM` bit. Because the `RD` bit = 0, no further action is required.
5. The master sees the Acknowledge and sends a RESTART instruction, followed by the first address byte with the `R/W` set to 1. The SLAVE mode I²C controller recognizes the RESTART instruction followed by the first address byte with a match to `SLA [9 : 8]`, and detects the `R/W` = 1 (the master reads from the slave). The slave I²C controller sets the `SAM` bit in the I2CISTAT register, which causes the slave address match interrupt. The `RD` bit is set = 1. The SLAVE mode I²C controller acknowledges on the bus.
6. The software responds to the interrupt by reading the I2CISTAT register, clearing the `SAM` bit. The software loads the initial data byte into the I2CDATA register and sets the `TXI` bit in the I2CCTL register.
7. The master starts the data transfer by asserting SCL Low. After the I²C controller has data available to transmit, the SCL is released, and the master proceeds to shift the first data byte.
8. After the first bit of the first data byte has been transferred, the I²C controller sets the `TDRE` bit which asserts the transmit data interrupt.
9. The software responds to the transmit data interrupt by loading the next data byte into the I2CDATA register.
10. The I²C master shifts in the remainder of the data byte. The master transmits the Acknowledge (or Not Acknowledge, if this byte is the final data byte).

11. The bus cycles through steps 7 to 10 until the final byte has been transferred. If the software has not yet loaded the next data byte when the master brings SCL Low to transfer the most significant data bit, the slave I²C controller holds SCL Low until the data register is written.

When a Not Acknowledge is received by the slave, the I²C controller sets the NCKI bit in the I2CISTAT register, causing the NAK interrupt to be generated.

12. The software responds to the NAK interrupt by clearing the TXI bit in the I2CCTL register and by asserting the FLUSH bit of the I2CCTL register.
13. When the master has completed the Acknowledge cycle of the last transfer, it asserts a STOP or RESTART condition on the bus.
14. The slave I²C controller asserts the STOP/RESTART interrupt (sets the SPRS bit in the I2CISTAT register).
15. The software responds to the STOP interrupt by reading the I2CISTAT register and clearing the SPRS bit.

I²C Data Register

The I²C Data register (Table 92) contains the data that is to be loaded into the Shift register to transmit onto the I²C bus. This register also contains data that is loaded from the Shift register after it is received from the I²C bus. The I²C Shift register is not accessible in the Register File address space, but is used only to buffer incoming and outgoing data.

Writes by the software to the I2CDATA register are blocked if a slave Write transaction is underway (the I²C controller is in SLAVE mode, and data is being received).

Table 92. I²C Data Register (I2CDATA)

BITS	7	6	5	4	3	2	1	0
FIELD	DATA							
RESET	0							
R/W	R/W							
ADDR	F50H							

I²C Interrupt Status Register

The read-only I²C Interrupt Status register (Table 93) indicates the cause of any current I²C interrupt and provides status of the I²C controller. When an interrupt occurs, one or more of the TDRE, RDRF, SAM, ARBLST, SPRS or NCKI bits is set. The GCA and RD bits do not generate an interrupt but rather provide status associated with the SAM bit interrupt.

Table 93. I²C Interrupt Status Register (I2CISTAT)

BITS	7	6	5	4	3	2	1	0
FIELD	TDRE	RDRF	SAM	GCA	RD	ARBLST	SPRS	NCKI
RESET	1	0	0	0	0	0	0	0
R/W	R	R	R	R	R	R	R	R
ADDR	F51H							

TDRE—Transmit Data Register Empty

When the I²C Controller is enabled, this bit is 1 when the I²C Data register is empty. When set, this bit causes the I²C Controller to generate an interrupt, except when the I²C Controller is shifting in data during the reception of a byte or when shifting an address and the RD bit is set. This bit clears by writing to the I2CDATA register.

RDRF—Receive Data Register Full

This bit is set = 1 when the I²C Controller is enabled and the I²C Controller has received a byte of data. When asserted, this bit causes the I²C Controller to generate an interrupt. This bit clears by reading the I2CDATA register.

SAM—Slave Address Match

This bit is set = 1 if the I²C Controller is enabled in Slave mode and an address is received which matches the unique Slave address or General Call Address (if enabled by the GCE bit in the I²C Mode register). In 10-bit addressing mode, this bit is not set until a match is achieved on both address bytes. When this bit is set, the RD and GCA bits are also valid. This bit clears by reading the I2CISTAT register.

GCA—General Call Address

This bit is set in Slave mode when the General Call Address or START byte is recognized (in either 7 or 10 bit Slave mode). The GCE bit in the I²C Mode register must be set to enable recognition of the General Call Address and START byte. This bit clears when IEN = 0 and is updated following the first address byte of each Slave mode transaction. A General Call Address is distinguished from a START byte by the value of the RD bit (RD = 0 for General Call Address, 1 for START byte).

RD—Read

This bit indicates the direction of transfer of the data. It is set when the Master is reading data from the Slave. This bit matches the least-significant bit of the address byte after the START condition occurs (for both Master and Slave modes). This bit clears when IEN = 0 and is updated following the first address byte of each transaction.

ARBLST—Arbitration Lost

This bit is set when the I²C Controller is enabled in Master mode and loses arbitration (outputs a 1 on SDA and receives a 0 on SDA). The ARBLST bit clears when the I2CISTAT register is read.

SPRS—Stop/Restart Condition Interrupt

This bit is set when the I²C Controller is enabled in Slave mode and detects a STOP or RESTART condition during a transaction directed to this slave. This bit clears when the I2CISTAT register is read. Read the RSTR bit of the I2CSTATE register to determine whether the interrupt was caused by a STOP or RESTART condition.

NCKI—NAK Interrupt

In Master mode, this bit is set when a Not Acknowledge condition is received or sent and neither the START nor the STOP bit is active. In Master mode, this bit can only be cleared by setting the START or STOP bits.

In Slave mode, this bit is set when a Not Acknowledge condition is received (Master reading data from Slave), indicating the Master is finished reading. A STOP or RESTART condition follows. In Slave mode this bit clears when the I2CISTAT register is read.

I²C Control Register

The I²C Control register (Table 94) enables and configures I²C operation.

Table 94. I²C Control Register (I2CCTL)

BITS	7	6	5	4	3	2	1	0
FIELD	IEN	START	STOP	BIRQ	TXI	NAK	FLUSH	FILTEN
RESET	0	0	0	0	0	0	0	0
R/W	R/W	R/W1	R/W1	R/W	R/W	R/W1	R/W	R/W
ADDR	F52H							

► **Note:** R/W1 - bit may be set (write 1) but not cleared.

IEN—I²C Enable

This bit enables the I²C Controller.

START—Send Start Condition

When set, this bit causes the I²C Controller (when configured as the Master) to send the Start condition. Once asserted, it is cleared by the I²C Controller after it sends the Start condition or by deasserting the IEN bit. If this bit is 1, it cannot be cleared by writing to the bit. After this bit is set, the START condition is sent if there is data in the I2CDATA or I2CSHIFT register. If there is no data in one of these registers, the I²C Controller waits until data is loaded. If this bit is set while the I²C Controller is shifting out data, it generates a RESTART condition after the byte shifts and the acknowledge phase completes. If the STOP bit is also set, it also waits until the STOP condition is sent before the START condition.

If START is set while a slave mode transaction is underway to this device, the START bit will be cleared and ARBLST bit in the Interrupt Status register will be set.

STOP—Send Stop Condition

When set, this bit causes the I²C Controller (when configured as the Master) to send the STOP condition after the byte in the I²C Shift register has completed transmission or after a byte has been received in a receive operation. When set, this bit is reset by the I²C Controller after a STOP condition has been sent or by deasserting the IEN bit. If this bit is 1, it cannot be cleared to 0 by writing to the register.

If STOP is set while a slave mode transaction is underway, the STOP bit will be cleared by hardware.

BIRQ—Baud Rate Generator Interrupt Request

This bit is ignored when the I²C Controller is enabled. If this bit is set = 1 when the I²C Controller is disabled (IEN = 0) the baud rate generator is used as an additional timer causing an interrupt to occur every time the baud rate generator counts down to one. The baud rate generator runs continuously in this mode, generating periodic interrupts.

TXI—Enable TDRE interrupts

This bit enables interrupts when the I²C Data register is empty.

NAK—Send NAK

Setting this bit sends a Not Acknowledge condition after the next byte of data has been received. It is automatically deasserted after the Not Acknowledge is sent or the IEN bit is cleared. If this bit is 1, it cannot be cleared to 0 by writing to the register.

FLUSH—Flush Data

Setting this bit clears the I²C Data register and sets the TDRE bit to 1. This bit allows flushing of the I²C Data register when an NAK condition is received after the next data byte has been written to the I²C Data register. Reading this bit always returns 0.

FILTEN—I²C Signal Filter Enable

Setting this bit enables low-pass digital filters on the SDA and SCL input signals. This function provides the spike suppression filter required in I2C Fast Mode. These filters reject any input pulse with periods less than a full system clock cycle. The filters introduce a 3-system clock cycle latency on the inputs.

I²C Baud Rate High and Low Byte Registers

The I²C Baud Rate High and Low Byte registers, shown in [Table 95](#) and [Table 96](#), combine to form a 16-bit reload value, BRG[15:0], for the I²C Baud Rate Generator.

The I²C baud rate is calculated using the following equation:

- **Note:** *If BRG = 0000h, use 10000h in the equation:*

$$\text{I}^2\text{C Baud Rate (bps)} = \frac{\text{System Clock Frequency (Hz)}}{4 \times \text{BRG}[15:0]}$$

Table 95. I²C Baud Rate High Byte Register (I2CBRH)

BITS	7	6	5	4	3	2	1	0
FIELD	BRH							
RESET	FFH							
R/W	R/W							
ADDR	F53H							

BRH = I²C Baud Rate High Byte

Most significant byte, BRG[15:8], of the I²C Baud Rate Generator's reload value.

- **Note:** *If the DIAG bit in the I²C Mode Register is set to 1, a read of the I2CBRH register returns the current value of the I²C Baud Rate Counter[15:8].*

Table 96. I²C Baud Rate Low Byte Register (I2CBRL)

BITS	7	6	5	4	3	2	1	0
FIELD	BRL							
RESET	FFH							
R/W	R/W							
ADDR	F54H							

BRL = I²C Baud Rate Low Byte

Least significant byte, BRG[7:0], of the I²C Baud Rate Generator's reload value.

- **Note:** *If the DIAG bit in the I²C Mode register is set to 1, a read of the I2CBRL register returns the current value of the I²C Baud Rate Counter[7:0].*

I²C State Register

The read-only I²C State register provides information about the state of the I²C bus and the I²C bus controller.

When the `DIAG` bit of the I²C Mode register is cleared, this register provides information on the internal state of the I²C controller and I²C bus (Table 97). A detailed discussion of each bit follows this table.

When the `DIAG` bit of the I²C Mode register is set, this register returns the value of the I²C controller state machine (Table 98).

Table 97. I²C State Register (I2CSTATE) - Description when DIAG = 0

BITS	7	6	5	4	3	2	1	0
FIELD	ACKV	ACK	AS	DS	10B	RSTR	SCLOUT	BUSY
RESET	0	0	0	0	0	0	X	X
R/W	R	R	R	R	R	R	R	R
ADDR	F55H							

ACKV—ACK Valid

This bit is set if sending data (Master or Slave) and the `ACK` bit in this register is valid for the byte just transmitted. This bit can be monitored if it is appropriate for software to verify the `ACK` value before writing the next byte to be sent. To operate in this mode, the data register must not be written when `TDRE` asserts; instead, software waits for `ACKV` to assert. This bit clears when transmission of the next byte begins or the transaction is ended by a `STOP` or `RESTART` condition.

ACK—Acknowledge

This bit indicates the status of the Acknowledge for the last byte transmitted or received. This bit is set for an Acknowledge and cleared for a Not Acknowledge condition.

AS—Address State

This bit is active High while the address is being transferred on the I²C bus.

DS—Data State

This bit is active High while the data is being transferred on the I²C bus.

10B—This bit indicates whether a 10 or 7-bit address is being transmitted when operating as a Master. After the `START` bit is set, if the five most-significant bits of the address are `11110B`, this bit is set. When set, it is reset once the address has been sent.

RSTR—RESTART

This bit is updated each time a `STOP` or `RESTART` interrupt occurs (`SPRS` bit set in `I2CISTAT` register).

- 0 = Stop condition
- 1 = Restart condition

SCLOUT—Serial Clock Output

Current value of Serial Clock being output onto the bus. The actual values of the `SCL` and `SDA` signals on the I²C bus can be observed via the GPIO Input register.

BUSY—I²C Bus Busy

0 = No activity on the I²C Bus.

1 = A transaction is underway on the I²C bus.

Table 98. I²C State Register (I2CSTATE) - Description when DIAG = 1

BITS	7	6	5	4	3	2	1	0
FIELD	I2CSTATE_H				I2CSTATE_L			
RESET	0	0	0	0	0	0	0	0
R/W	R	R	R	R	R	R	R	R
ADDR	F55H							

I2CSTATE_H—I²C State

This field defines the current state of the I²C Controller. It is the most significant nibble of the internal state machine. [Table 99](#) defines the states for this field.

I2CSTATE_L—Least significant nibble of the I²C state machine. This field defines the substates for the states defined by I2CSTATE_H. [Table 100](#) defines the values for this field.

Table 99. I2CSTATE_H

State Encoding	State Name	State Description
0000	Idle	I ² C bus is idle or I ² C controller is disabled.
0001	Slave Start	I ² C controller has received a START condition.
0010	Slave Bystander	Address did not match; ignore remainder of transaction.
0011	Slave Wait	Waiting for STOP or RESTART condition after sending a Not Acknowledge instruction.
0100	Master Stop2	Master completing STOP condition (SCL = 1, SDA = 1).
0101	Master Start/Restart	MASTER mode sending START condition (SCL = 1, SDA = 0).
0110	Master Stop1	Master initiating STOP condition (SCL = 1, SDA = 0).
0111	Master Wait	Master received a Not Acknowledge instruction, waiting for software to assert STOP or START control bits.
1000	Slave Transmit Data	9 substates, one for each data bit and one for the Acknowledge.
1001	Slave Receive Data	9 substates, one for each data bit and one for the Acknowledge.
1010	Slave Receive Addr1	Slave receiving first address byte (7- and 10-bit addressing) 9 substates, one for each address bit and one for the Acknowledge.

Table 99. I2CSTATE_H (Continued)

State Encoding	State Name	State Description
1011	Slave Receive Addr2	Slave Receiving second address byte (10-bit addressing) 9 substates, one for each address bit and one for the Acknowledge.
1100	Master Transmit Data	9 substates, one for each data bit and one for the Acknowledge.
1101	Master Receive Data	9 substates, one for each data bit and one for the Acknowledge.
1110	Master Transmit Addr1	Master sending first address byte (7- and 10-bit addressing) 9 substates, one for each address bit and one for the Acknowledge.
1111	Master Transmit Addr2	Master sending second address byte (10-bit addressing) 9 substates, one for each address bit and one for the Acknowledge.

Table 100. I2CSTATE_L

State I2CSTATE_H	Substate I2CSTATE_L	Substate Name	State Description
0000–0100	0000	—	There are no substates for these I2CSTATE_H values.
0110–0111	0000	—	There are no substates for these I2CSTATE_H values.
0101	0000	Master Start	Initiating a new transaction
	0001	Master Restart	Master is ending one transaction and starting a new one without letting the bus go idle.
1000–1111	0111	send/receive bit 7	Sending/Receiving most significant bit
	0110	send/receive bit 6	
	0101	send/receive bit 5	
	0100	send/receive bit 4	
	0011	send/receive bit 3	
	0010	send/receive bit 2	
	0001	send/receive bit 1	
	0000	send/receive bit 0	Sending/Receiving least significant bit
	1000	send/receive Acknowledge	Sending/Receiving Acknowledge

I²C Mode Register

The I²C Mode register (Table 101) provides control over master versus slave operating mode, slave address, and diagnostic modes.

Table 101. I²C Mode Register (I2CMODE)

BITS	7	6	5	4	3	2	1	0
FIELD	Reserved	MODE[1:0]		IRM	GCE	SLA[9:8]		DIAG
RESET	0	0		0	0	0		0
R/W	R	R/W		R/W	R/W	R/W		R/W
ADDR	F56H							

MODE—Selects the I²C Controller operational mode

00 = Master/Slave capable (supports multi-Master arbitration) with 7-bit Slave address
 01 = Master/Slave capable (supports multi-Master arbitration) with 10-bit Slave address
 10 = Slave Only capable with 7-bit address
 11 = Slave Only capable with 10-bit address

IRM—Interactive Receive Mode

Valid in Slave mode when software needs to interpret each received byte before acknowledging. This bit is useful for processing the data bytes following a General Call Address or if software wants to disable hardware address recognition.

0 = Acknowledge occurs automatically and is determined by the value of the NAK bit of the I2CCTL register.

1 = A receive interrupt is generated for each byte received (address or data). The SCL is held Low during the acknowledge cycle until software writes to the I2CCTL register. The value written to the NAK bit of the I2CCTL register is output on SDA. This value allows software to Acknowledge or Not Acknowledge after interpreting the associated address/data byte.

GCE—General Call Address Enable

Enables reception of messages beginning with the General Call Address or START byte.

0 = Do not accept a message with the General Call Address or START byte.

1 = Do accept a message with the General Call Address or START byte. When an address match occurs, the GCA and RD bits in the I²C Status register indicates whether the address matched the General Call Address/START byte or not. Following the General Call Address byte, software may set the IRM bit that allows software to examine the following data byte(s) before acknowledging.

SLA[9:8]— Slave Address Bits 9 and 8

Initialize with the appropriate Slave address value when using 10-bit Slave addressing. These bits are ignored when using 7-bit Slave addressing.

DIAG—Diagnostic Mode

Selects read back value of the Baud Rate Reload and State registers.

0 = Reading the Baud Rate registers returns the Baud Rate register values. Reading the State register returns I²C Controller state information

1 = Reading the Baud Rate registers returns the current value of the baud rate counter. Reading the State register returns additional state information.

I²C Slave Address Register

The I²C Slave Address register (Table 102) provides control over the lower order address bits used in 7- and 10-bit slave address recognition.

Table 102. I²C Slave Address Register (I2CSLVAD)

BITS	7	6	5	4	3	2	1	0
FIELD	SLA[7:0]							
RESET	00H							
R/W	R/W							
ADDR	F57H							

SLA[7:0] — Slave Address Bits 7-0. Initialize with the appropriate Slave address value. When using 7 bit Slave addressing, SLA[9:7] are ignored.



Comparator and Operational Amplifier

The Z8FMC16100 Series Flash MCU devices feature a general-purpose comparator and an operational amplifier. The comparator is a moderate speed (200 ns propagation delay) device that is designed for a maximum input offset of 5 mV. The comparator is used to compare two analog input signals. General-purpose input pins (CINP and CINN) provide the comparator inputs. The output is available as an interrupt source.

The operational amplifier is a two-input, one-output operational amplifier with a open loop gain of 10,000 (80 dB). One general-purpose input pin (OPINP) provides a non-inverting amplifier input, while another general-purpose input pin (OPINN) provides the inverting amplifier input. The output is available at the output pin (OPOUT).

The key operating characteristics of the operational amplifier are:

- Input common-mode range from GND (0.0 V) to $V_{DD} - 1$ V
- Input offset voltage less than 15 mV
- Output voltage swing from GND + 0.1 V to $V_{DD} - 0.1$ V
- Input bias current less than 1 nA
- Operating the operational amplifier open loop (no feedback) effectively provides another on-chip comparator (if appropriate)

Comparator Operation

The comparator output reflects the relationship between the non-inverting input and the inverting (reference) input. If the voltage on the non-inverting input is higher than the voltage on the inverting input, the comparator output is at a High state. If the voltage on the non-inverting input is lower than the voltage on the inverting input, the comparator output is at a Low state.

To operate, the comparator must be enabled by setting the `CMPEN` bit in the Comparator and Op Amp Register to 1. In addition the `CINP` and `CINN` comparator input alternate functions must be enabled on their respective GPIO pins. For more information, see [GPIO Alternate Functions](#) on page 34.

The comparator does not automatically power-down. To reduce operating current when not in use, the comparator is disabled by clearing the `CMPEN` bit to 0.

Operational Amplifier Operation

To operate, the operational amplifier must be enabled by setting the `OPEN` bit in the Comparator and Op Amp Register to 1. In addition, the `OPINP`, `OPINN`, and `OPOUT` alternate functions must be enabled on their respective GP I/O pins. For more information, see [GPIO Alternate Functions](#) on page 34.

The logical value of the operational amplifier output (`OPOUT`) can be read from the Port 3 data input register if both the operational amplifier and input pin Schmitt trigger are enabled. For more information, see [GPIO Alternate Functions](#) on page 34. The operational amplifier can also generate an interrupt through the GPIO Port B3 input interrupt, if enabled.

The output of the operational amplifier is also connected to an analog input (`ANA3`) of the Analog-to-Digital Converter (ADC) multiplexer.

The operational amplifier does not automatically power-down. To reduce operating current when not in use, the operational amplifier is disabled by clearing the `OPEN` bit in the Comparator and Op Amp register to 0. When the operational amplifier is disabled, the output is high-impedance. Operation of operational amplifier in unity gain mode may require external compensation.

Interrupts

The comparator generates an interrupt on any change in the logic output value (from 0 to 1 and 1 to 0). For information on enabling and prioritization of the comparator interrupt, see [Interrupt Controller](#) on page 49.

Comparator and Op Amp Control Register

The Comparator and Op Amp Control (`CMPOPC`) register ([Table 103](#)) enables the comparator and operational amplifier and provides access to the comparator output.

Table 103. Comparator and Op Amp Control Register (CMPOPC)

BITS	7	6	5	4	3	2	1	0
FIELD	OPEN	Reserved		CPSEL	CMPIRQ	CMPIV	CMPOUT	CMPEN
RESET	0	00		0	0	0	X	0
R/W	R/W	R/W		R/W	R/W	R/W	R	R/W
ADDR	F90H							

Bit Position	Value (H)	Description
[7] OPEN	0	Operational Amplifier Disable Operational amplifier is disabled.
	1	Operational amplifier is enabled.
[6:5] Reserved		Must be 0.
[4] CPSEL	0	Comparator Input Select Comparator input is PA1
	1	Comparator input is PB4
[3] CMPIRQ	0	Comparator Interrupt Edge Select Interrupt Request on Comparator Rising Edge
	1	Interrupt Request on Comparator Falling Edge
[2] CMPIV	0	PWM Fault Comparator Polarity PWM Fault is active when CP- > CP+
	1	PWM Fault is active when CP+ > CP-
[1] CMPOUT	0	Comparator Output Value Comparator output is logical 0.
	1	Comparator output is logical 1.
[0] CMPEN	0	Comparator Enable Comparator is disabled.
	1	Comparator is enabled.



Analog-to-Digital Converter

The Z8FMC16100 Series Flash MCU includes an eight-channel Analog-to-Digital Converter (ADC). The ADC converts an analog input signal to a 10-bit binary number.

The features of the successive-approximation ADC include:

- Eight analog input sources multiplexed with general-purpose I/O ports
- Fast conversion time, less than 5 μ s
- Programmable timing controls
- Interrupt upon conversion complete
- Internal voltage reference generator
- Internal reference voltage available externally
- Ability to supply external reference voltage
- Timer count capture on every ADC conversion

Architecture

Figure 36 displays the ADC architecture which consists of an 8-input multiplexer, sample-and-hold amplifier, and 10-bit successive-approximation ADC. The ADC digitizes the signal on a selected channel and stores the digitized data in the ADC data registers. In environments with high electrical noise, an external RC filter must be added at the input pins to reduce high-frequency noise.

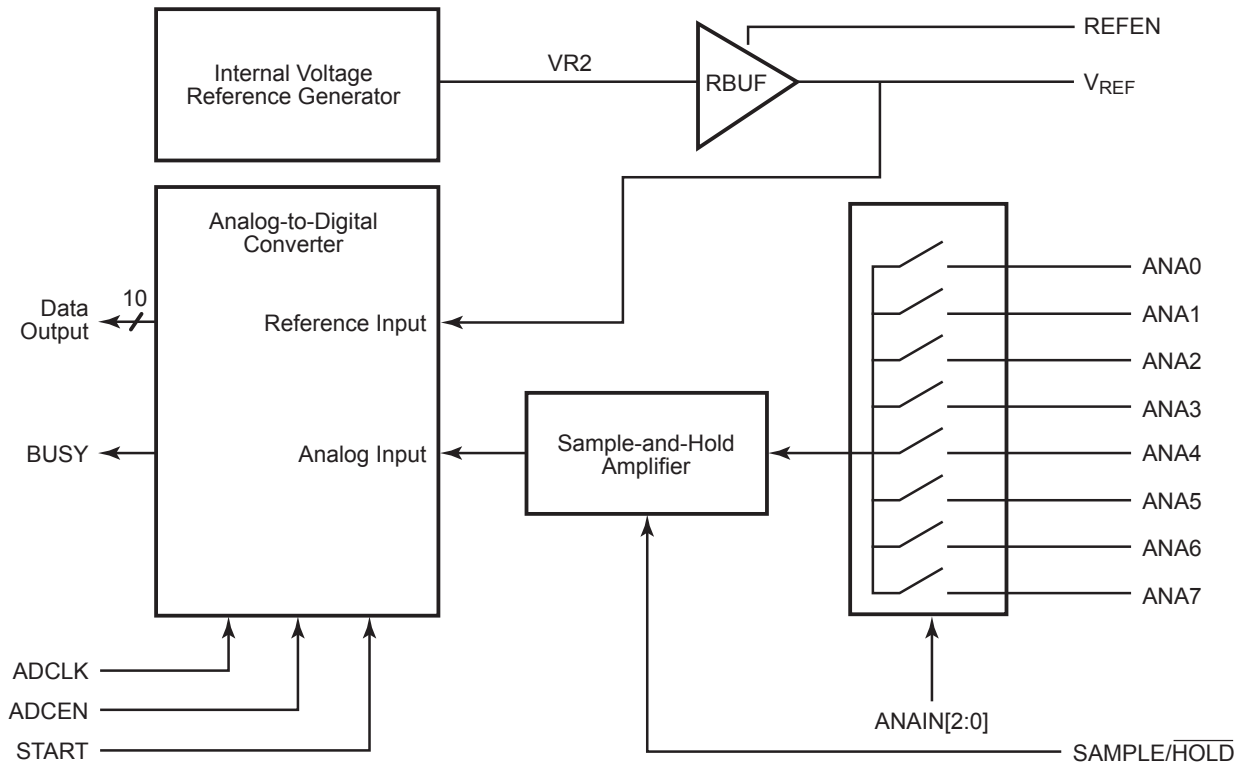

Figure 36. Analog-to-Digital Converter Block Diagram

Operation

The ADC converts an analog input (ANA_x) to a 10-bit digital representation. The equation for calculating the digital value is given below:

$$\text{ADC Output} = 1024 \times (ANA_x \div V_{REF})$$

Assuming zero gain and offset errors, any voltage outside the ADC input limits of AV_{SS} and V_{REF} returns all 0s or 1s, respectively.

A new conversion is initiated by either software write to the ADC Control register's `START` bit or by PWM trigger. For information on the PWM trigger, see [Synchronization of PWM and Analog-to-Digital Converter](#) on page 71.

To avoid disrupting a conversion already in progress, the START bit can be read to indicate ADC operation status (busy or available).



Caution: *Starting a new conversion while another conversion is in progress will stop the conversion in progress and the new conversion will not complete.*

ADC Timing

Each ADC measurement consists of 3 phases:

1. Input sampling (programmable, minimum of 1.0 μ s).
2. Sample-and-hold amplifier settling (programmable, minimum of 0.5 μ s).
3. Conversion is 13 ADCLK cycles.

Figure 37 displays the control and flow of an ADC conversion.

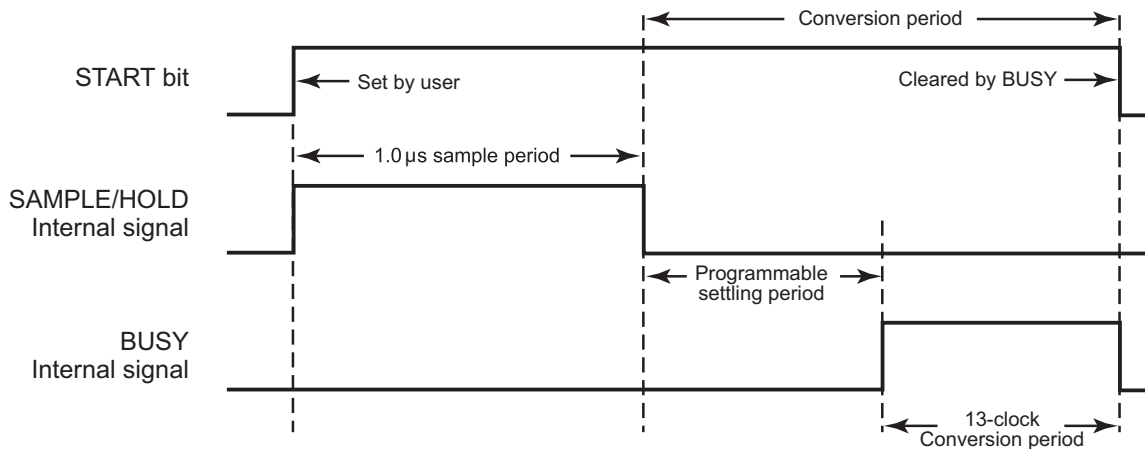

Figure 37. ADC Timing Diagram

Figure 38 displays the timing of an ADC convert period.

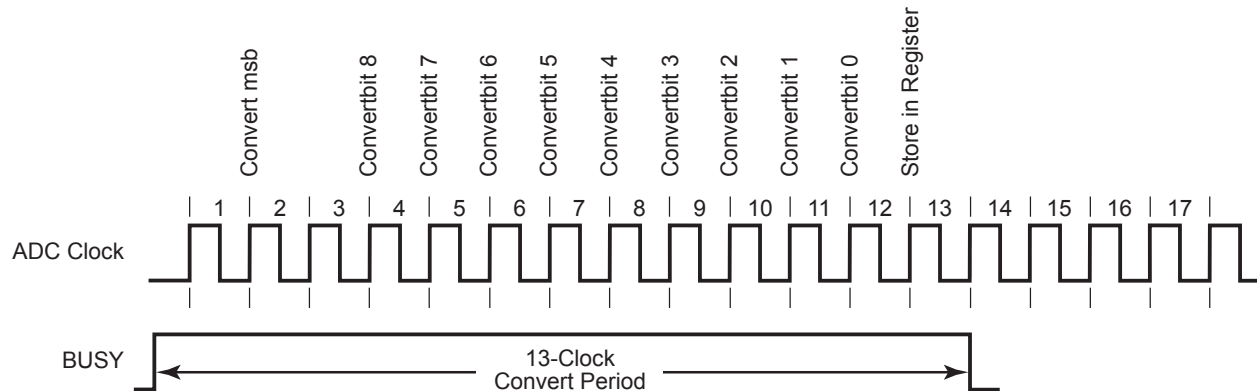

Figure 38. ADC Convert Timing

ADC Interrupt

The ADC can generate an interrupt request when a conversion is completed. An interrupt request that is pending when the ADC is disabled is not automatically cleared.

ADC Timer 0 Capture

The Timer 0 count is captured for every ADC conversion. The capture of the Timer 0 count occurs after the programmed sample time is complete for every conversion and stored in the ADC Timer Capture register (ADCTCAP).

Reference Buffer

The reference buffer (RBUF) supplies the reference voltage for the ADC. When enabled, the internal voltage reference generator supplies the ADC and the voltage is available on the V_{REF} pin. When RBUF is disabled, the ADC must have the reference voltage supplied externally through the V_{REF} pin. RBUF is controlled by the REFEN bit in the ADC Control register.

Internal Voltage Reference Generator

The Internal Voltage Reference Generator provides the voltage (VR2) for the RBUF. VR2 is 2 V.

Calibration and Compensation

You can perform calibration and store the values into Flash, or the user code can perform a manual offset calibration. There is no provision for manual gain calibration.

ADC Control Register 0

The ADC Control register 0 (ADCCTL0) initiates the analog-to-digital conversion and provides ADC status information. See [Table 104](#).

Table 104. ADC Control Register 0 (ADCCTL0)

BITS	7	6	5	4	3	2	1	0
FIELD	START	Reserved	REFEN	ADCEN	Reserved	ANAIN[2:0]		
RESET	0	0	0	0	0	0	0	0
R/W	R/W1	R/W	R/W	R/W	R/W	R/W	R/W	R/W
ADDR	F70H							

Bit Position	Value (H)	Description
[7] START	0	<u>ADC Start / Busy</u> Writing to 0 has no effect. Reading a 0 indicates the ADC is available to begin a conversion.
	1	Writing to 1 starts a conversion. Reading a 1 indicates a conversion is currently in progress.
[6]	0	Reserved—Must Be 0.
[5] REFEN	0	<u>Reference Enable</u> Internal reference voltage is disabled allowing an external reference voltage to be used by the ADC.
	1	Internal reference voltage for the ADC is enabled. The internal reference voltage can be measured on the VREF pin.
[4] ADCEN	0	<u>ADC Enable</u> ADC is disabled for low power operation.
	1	ADC is enabled for normal use.
[3] Reserved	0	Reserved—Must Be 0.

[2:0] ANAIN		<u>Analog Input Select</u>
	000	ANA0 input is selected for analog-to-digital conversion.
	001	ANA1 input is selected for analog-to-digital conversion.
	010	ANA2 input is selected for analog-to-digital conversion.
	011	ANA3 input is selected for analog-to-digital conversion.
	100	ANA4 input is selected for analog-to-digital conversion.
	101	ANA5 input is selected for analog-to-digital conversion.
	110	ANA6 input is selected for analog-to-digital conversion.
	111	ANA7 input is selected for analog-to-digital conversion.

ADC Raw Data High Byte Register

The ADC Data Raw High Byte register ([Table 105](#)) contains the upper eight bits of raw data from the ADC output. Access to the ADC Raw Data High Byte register is Read-Only. This register is used for test only.

Table 105. ADC Raw Data High Byte Register (ADCRD_H)

BITS	7	6	5	4	3	2	1	0
FIELD	ADCRDH							
RESET	X							
R/W	R							
ADDR	F71H							

Bit Position	Value (H)	Description
[7:0] ADCRDH	00H–FFH	ADC Raw Data High Byte The data in this register is the raw data coming from the SAR Block. It will change as the conversion is in progress. This register is used for testing only.

ADC Data High Byte Register

The ADC Data High Byte register ([Table 106](#)) contains the upper eight bits of the ADC output. Access to the ADC Data High Byte register is Read-Only. Reading the ADC Data High Byte register latches data in the ADC Low Bits register.

Table 106. ADC Data High Byte Register (ADCD_H)

BITS	7	6	5	4	3	2	1	0
FIELD	ADCDH							
RESET	X							
R/W	R							
ADDR	F72H							

Bit Position	Value (H)	Description
[7:0]	00H–FFH	ADC High Byte The last conversion output is held in the data registers until the next ADC conversion has completed.

ADC Data Low Bits Register

The ADC Data Low Bits register ([Table 107](#)) contain the lower bits of the ADC output as well as an overflow status bit. Access to the ADC Data Low Bits register is Read-Only. Reading the ADC Data High Byte register latches data in the ADC Low Bits register.

Table 107. ADC Data Low Bits Register (ADCD_L)

BITS	7	6	5	4	3	2	1	0
FIELD	ADCDL		Reserved					
RESET	X		X					
R/W	R		R					
ADDR	F73H							

Bit Position	Value (H)	Description
[7:6]	00–11b	ADC Low Bits These bits are the 2 least significant bits of the 10-bit ADC output. These bits are undefined after a Reset. The low bits are latched into this register whenever the ADC Data High Byte register is read.
[5:0] Reserved	0	Reserved—Must Be 0.

Sample Settling Time Register

The Sample Settling Time register (Table 108) is used to program the length of time from the SAMPLE/HOLD signal to the START signal, when the conversion can begin. The number of clock cycles required for settling varies from system to system depending on the system clock period used. You must program this register to contain the number of clocks required to meet a 0.5 μs minimum settling time.

Table 108. Sample and Settling Time (ADCSST)

BITS	7	6	5	4	3	2	1	0
FIELD	Reserved			SST				
RESET	0			1	1	1	1	1
R/W	R			R/W				
ADDR	F74H							

Bit Position	Value (H)	Description
[7:5]	0H	Reserved—Must be 0.
[4:0] SST	0H–FH	Sample settling time in number of system clock periods to meet 0.5 μs minimum.

Sample Time Register

The Sample Time register (Table 109) is used to program the length of active time for the sample after a conversion has begun by setting the START bit in the ADC Control register or initiated by the PWM. The number of system clock cycles required for sample time varies from system to system, depending on the clock period used. You must program this register to contain the number of system clocks required to meet a 1 μs minimum sample time.

Table 109. Sample Hold Time (ADCST)

BITS	7	6	5	4	3	2	1	0
FIELD	Reserved		ST					
RESET	0		1	1	1	1	1	1
R/W	R/W		R/W					
ADDR	F75H							

Bit Position	Value (H)	Description
[7:6]	0H	Reserved—Must be 0.
[5:0] SHT	0H–FH	Sample Hold time in number of system clock periods to meet 1 μ s minimum.

ADC Clock Prescale Register

The ADC Clock Prescale register (Table 110) is used to provide a divided system clock to the ADC. When this register is programmed with 0h, the System Clock is used for the ADC Clock.

Table 110. ADC Clock Prescale Register (ADCCP)

BITS	7	6	5	4	3	2	1	0
FIELD	Reserved				DIV16	DIV8	DIV4	DIV2
RESET	0				0	0	0	0
R/W	R/W							
ADDR	F76H							

Bit Position	Value (H)	Description
[0] DIV2	0	<u>DIV2</u> Clock is not divided
	1	System Clock is divided by 2 for ADC Clock

[1] DIV4	0	<u>DIV4</u> Clock is not divided
	1	System Clock is divided by 4 for ADC Clock
[2] DIV8	0	<u>DIV8</u> Clock is not divided
	1	System Clock is divided by 8 for ADC Clock
[3] DIV16	0	<u>DIV16</u> Clock is not divided
	1	System Clock is divided by 16 for ADC Clock
[7:4]	0H	Reserved—must be 0.

ADC Timer Capture High Byte Register

The High byte of the ADC Timer Capture register (Table 111) contains the upper eight bits of the ADC Timer 0 count. Access to the ADC Timer Capture High Byte register is Read-Only.

Table 111. ADC Timer Capture High Byte Register (ADCTCAP_H)

BITS	7	6	5	4	3	2	1	0
FIELD	ADCTCAPH							
RESET	X							
R/W	R							
ADDR	F08H							

Bit Position	Value (H)	Description
[7:0] ADCTCAPH	00H–FFH	ADC Timer Capture Count High Byte The timer count is held in the data registers until the next ADC conversion is started.

ADC Timer Capture Low Byte Register

The low byte of the ADC Timer Capture Low Byte register (Table 112) contains the lower eight bits of the ADC Timer 0 count. Access to the ADC Timer Capture Low Byte register is Read-Only.

Table 112. ADC Timer Capture Low Byte Register (ADCTCAP_L)

BITS	7	6	5	4	3	2	1	0
FIELD	ADCTCAPL							
RESET	X							
R/W	R							
ADDR	F09H							

Bit Position	Value (H)	Description
[7:0] ADCTCAPL	00H–FFH	ADC Timer Capture Count Low Byte The timer count is held in the data registers until the next ADC conversion is started.

Program Memory

The Z8FMC16100 Series Flash MCU products feature up to 16 KB (16,384 bytes) of non-volatile Flash memory with read/write/erase capability. Flash memory can be programmed and erased in-circuit by either user code or through the On-Chip Debugger (OCD).

The Flash memory array is arranged in 512 byte pages. The 512 byte page is the minimum Flash block size which can be erased. Flash memory is also divided into 8 sectors which can be protected from programming and erase operations on a per sector basis.

[Table 113](#) describes the Flash memory configuration for each device in the Z8FMC16100 Series Flash MCU. [Table 114](#) lists the sector address ranges. [Figure 39](#) displays the Flash memory arrangement.

Table 113. Flash Memory Configurations

Part Number	Flash Size	Number of Pages	Program Memory Addresses	Sector Size	Number of Sectors	Pages per Sector
Z8FMC16	16 K (16,384)	32	0000h–3FFFh	2 K (2048)	8	4
Z8FMC08	8 K (8,192)	16	0000h–1FFFh	1 K (1024)	8	2
Z8FMC04	4 K (4,096)	8	0000h–0FFFh	512	8	1

Table 114. Flash Memory Sector Addresses

Sector Number	Flash Sector Address Ranges		
	Z8FMC16	Z8FMC08	Z8FMC04
0	0000h–07FFh	0000h–03FFh	0000h–01FFh
1	0800h–0FFFh	0400h–07FFh	0200h–03FFh
2	1000h–17FFh	0800h–0BFFh	0400h–05FFh
3	1800h–1FFFh	0C00h–0FFFh	0600h–07FFh
4	2000h–27FFh	1000h–13FFh	0800h–09FFh
5	2800h–2FFFh	1400h–17FFh	0A00h–0BFFh
6	3000h–37FFh	1800h–1BFFh	0C00h–0DFFh
7	3800h–3FFFh	1C00h–1FFFh	0E00h–0FFFh

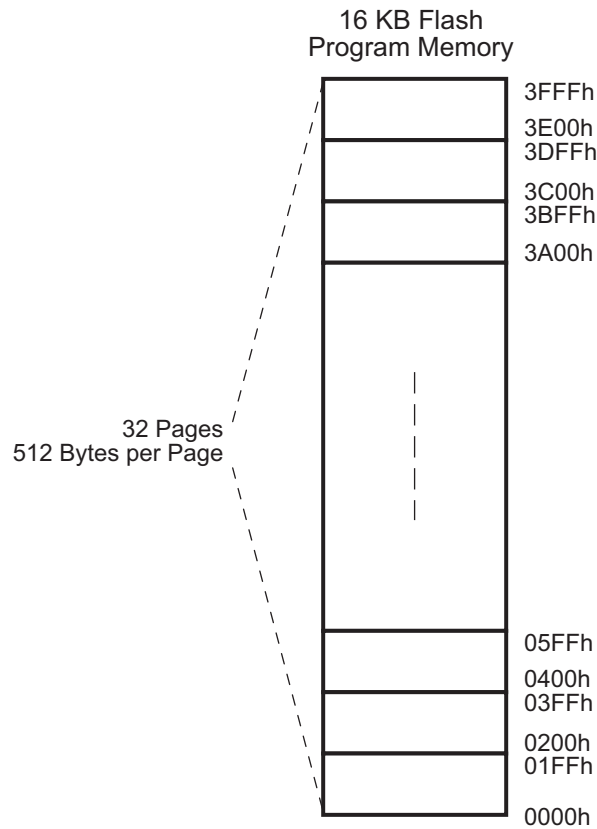

Figure 39. Flash Memory Arrangement

Information Area

Table 115 describes the Z8FMC16100 Series Flash MCU's information area. This 512 byte information area is accessed by setting bit 7 of the Page Select Register to 1. When access is enabled, the information area is mapped into Program Memory and overlays the 512 bytes at addresses FE00h to FFFFh. When information area access is enabled, LDC instructions return data from the information area. CPU instruction fetches always arrive from Program Memory regardless of the information area access bit. Access to the information area is Read-Only.

Table 115. Z8FMC16100 Series Flash MCU Information Area Map

Program Memory Address (Hex)	Function
FE00h–FE3Fh	Reserved.
FE40h–FE53h	Part Number: 20-character ASCII alphanumeric code, left-justified, and filled with zeroes.
FE54h–FFFFh	Reserved.

Operation

The Flash Controller provides proper signals and timing for the Byte Programming, Page Erase, and Mass Erase operations in Flash memory. The Flash Controller contains a protection mechanism, through the Flash Control Register (FCTL) to prevent accidental programming or erasure. The following sections provide details about the Lock, Unlock, Sector Protect, Byte Programming, Page Erase, and Mass Erase operations:

- [Timing Using Flash Frequency Registers](#)
- [Flash Read Protection](#)
- [Flash Write/Erase Protection](#)
- [Byte Programming](#)
- [Page Erase](#)
- [Mass Erase](#)
- [Flash Controller Bypass](#)
- [Flash Controller Behavior in Debug Mode](#)

Timing Using Flash Frequency Registers

Before performing a program or erase operation on Flash memory, you must first configure the Flash Frequency High and Low Byte registers. The Flash Frequency registers allow programming and erasure of Flash with system clock frequencies ranging from 32 kHz through 20 MHz (valid range is limited to device operating frequencies).

The Flash Frequency High and Low Byte registers combine to form a 16-bit value, FFREQ, to control the timing of Flash program and erase operations. The 16-bit Flash Frequency value must contain the system clock frequency in kHz. This value is calculated using the following equation:

$$\text{FFREQ}[15:0] = \frac{\text{System Clock Frequency (Hz)}}{1000}$$



Caution: *Flash programming and erasure are not supported for system clock frequencies below 32 kHz, above 20 MHz, or outside of the device's operating frequency range. The Flash Frequency High and Low Byte registers must be loaded with the correct value to ensure proper Flash programming and erase operations.*

Flash Read Protection

The user code within Flash memory can be protected from external access. Programming the Flash Read Protect option bit prevents the reading of user code by the OCD or by using the Flash Controller Bypass mode. For more information, see [Option Bits](#) on page 221 and [On-Chip Debugger](#) on page 239.

Flash Write/Erase Protection

The Z8FMC16100 Series Flash MCU device provides several levels of protection against accidental program and erasure of the contents of Flash memory. This protection is provided by:

- [Flash Controller Unlock Mechanism](#)
- [Flash Sector Protection](#)
- [Flash Write Protection Option Bit](#)

Flash Controller Unlock Mechanism

On Reset, the Flash Controller locks to prevent accidental program or erasure of Flash memory. To program or erase Flash memory, the Flash Controller must be unlocked. After unlocking the Flash Controller, the Flash can be programmed or erased. Any value written by user code to the Flash Control register or Page Select register out of sequence locks the Flash Controller.

Follow the steps below to unlock the Flash Controller from user code:

1. Write 00h to the Flash Control register to reset the Flash Controller.
2. Write the page to be programmed or erased to the Page Select register.
3. Write the first unlock command 73h to the Flash Control register.
4. Write the second unlock command 8Ch to the Flash Control register.
5. Rewrite the page written in [Step 2](#) to the Page Select register.

Flash Sector Protection

The Flash Sector Protect register can be configured to prevent sectors from being programmed or erased. After a sector is protected, it cannot be unprotected by user code. The Flash Sector Protect register is cleared after reset and any previously written protection values are lost. User code must write this register in their initialization routine to enable sector protection.

The Flash Sector Protect register shares its Register File address with the Page Select register. The Flash Sector Protect register is accessed by writing the Flash Control register with 5EH. After the Flash Sector Protect register is selected, it can be accessed at the Page Select register address. When user code writes the Flash Sector Protect register, bits can only be set to 1. Therefore, sectors can be protected, but not unprotected, through register Write operations. The Flash Sector Protect register is deselected by writing any value to the Flash Control register.

Follow the steps below to setup the Flash Sector Protect register from user code:

1. Write 00h to the Flash Control register to reset the Flash Controller.
2. Write 5EH to the Flash Control register to select the Flash Sector Protect register.
3. Read and/or write the Flash Sector Protect register, which now resides at Register File address FF9h.
4. Write 00h to the Flash Control register to return the Flash Controller to its reset state.

Flash Write Protection Option Bit

The Flash Write Protect option bit can be enabled to block all program and erase operations from user code. For more information, see [Option Bits](#) on page 221.

Byte Programming

When the Flash Controller is unlocked, Writes to Program Memory from user code programs a byte into the Flash if the address is located in the unlocked page. An erased Flash byte contains all ones (FFh). The programming operation can only be used to change bits from 1 to 0. To change a Flash bit (or multiple bits) from 0 to 1 requires a Page Erase or Mass Erase operation.

Byte programming can be performed using the eZ8 CPU's LDC or LDCI instructions. For description of the LDC and LDCI instructions, refer to *eZ8 CPU User Manual (UM0128)*.

When the Flash Controller programs Flash memory, the eZ8 CPU idles, but system clock and on-chip peripherals continue to operate. Interrupts which occur when a programming operation is in progress are serviced after the programming operation is complete. To exit programming mode and lock the Flash Controller, write 00h to the Flash Control register.

User code cannot program Flash Memory on a page which lies in a protected sector. When user code writes memory locations, only addresses located in the unlocked page are programmed. Memory Writes outside of the unlocked page are ignored.



Caution: *Each memory location must not be programmed more than twice before an erase is required.*

Follow the steps below to program Flash memory from user code:

1. Write 00h to the Flash Control register to reset the Flash Controller.
2. Write the page of memory to be programmed to the Page Select register.
3. Write the first unlock command 73h to the Flash Control register.
4. Write the second unlock command 8Ch to the Flash Control register.
5. rewrite the page written in [Step 2](#) to the Page Select register.
6. Write Program Memory using LDC or LDCI instructions to program Flash.
7. Repeat [Step 6](#) to program additional memory locations on the same page.
8. Write 00h to the Flash Control register to lock the Flash Controller.

Page Erase

Flash memory can be erased one page (512 bytes) at a time. Page-erasing Flash memory sets all bytes in that page to the value FFh. The Page Select register identifies the page to be erased. While the Flash Controller executes the Page Erase operation, the eZ8 CPU idles, but the system clock and on-chip peripherals continue to operate. The eZ8 CPU resumes operation after the Page Erase operation completes. Interrupts which occur when the Page Erase operation is in progress are serviced after the Page Erase operation is complete. When the Page Erase operation is complete, the Flash Controller returns to its locked state. Only pages located in unprotected sectors can be erased.

Follow the steps below to perform a Page Erase operation:

1. Write 00h to the Flash Control register to reset the Flash Controller.
2. Write the page to be erased to the Page Select register.
3. Write the first unlock command (73h) to the Flash Control register.
4. Write the second unlock command 8Ch to the Flash Control register.
5. Rewrite the page written in [Step 2](#) to the Page Select register.
6. Write the Page Erase command (95h) to the Flash Control register.

Mass Erase

The Flash memory cannot be mass-erased by user code.

Flash Controller Bypass

The Flash Controller can be bypassed and the control signals for Flash memory are brought out to the GPIO pins. Bypassing the Flash Controller allows faster programming algorithms by controlling the Flash programming signals directly.

Flash Controller Bypass is recommended for gang-programming applications and large-volume customers who do not require in-circuit programming of Flash memory.

For more information on bypassing the Flash controller, refer to *Third-Party Flash Programming Support for the Z8 Encore!® MC Application Note (AN0117)* available for download at www.zilog.com.

Flash Controller Behavior in Debug Mode

The following changes in behavior of the Flash Controller occur when the Flash Controller is accessed using the OCD:

- The Flash Write Protect option bit is ignored.
- The Flash Sector Protect register is ignored for programming and erase operations.
- Programming operations are not limited to the page selected in the Page Select register.
- Bits in the Flash Sector Protect register can be written to 1 or 0.
- The second write of the Page Select register to unlock the Flash Controller is not necessary.
- The Page Select register can be written when the Flash Controller is unlocked.
- The Mass Erase command is enabled through the Flash Control register.
- The page erase and programming operations are disabled if the Memory Read Protect option is enabled.

Flash Control Register Definitions

The Flash Control register ([Table 116](#)) unlocks the Flash Controller for programming and erase operations or to select the Flash Sector Protect register.

The Write-Only Flash Control register shares its Register File address with the Read-Only Flash Status register.

Table 116. Flash Control Register (FCTL)

BITS	7	6	5	4	3	2	1	0
FIELD	FCMD							
RESET	00H							
R/W	W							
ADDR	FF8H							

Bit Position	Value	Description
[7:0]		Flash Command
FCMD	73H	First unlock command.
	8CH	Second unlock command.
	95H	Page erase command.
	63H	Mass erase command.
	5EH	Flash Sector Protect register select.
		All other commands or any command out of sequence locks the Flash Controller.

Flash Status Register

The Flash Status register ([Table 117](#)) indicates the current state of the Flash Controller. This register can be read at any time. The read-only Flash Status register shares its Register File address with the Write-only Flash Control register.

Table 117. Flash Status Register (FSTAT)

BITS	7	6	5	4	3	2	1	0
FIELD	Reserved		FSTAT					
RESET	00B		00_0000B					
R/W	R		R					
ADDR	FF8H							

Bit Position	Value	Description
[7:6] Reserved		Must be 00.
[5:0] FSTAT		Flash Controller Status
	00_0000	Flash Controller locked.
	00_0001	First unlock command received.
	00_0010	Second unlock command received.
	00_0011	Flash Controller unlocked.
	00_0100	Flash Sector Protect register selected.
	00_1xxx	Program operation in progress.
	01_0xxx	Page erase operation in progress.
	10_0xxx	Mass erase operation in progress.

Flash Page Select Register

The Flash Page Select (FPS) register ([Table 118](#)) selects one of the 32 available Flash memory pages to be erased or programmed. Each Flash Page contains 512-bytes of Flash memory. During a Page Erase operation, all Flash memory locations with the 7 most significant bits of the address assigned by the PAGE field are erased to FFh.

The Flash Page Select register shares its Register File address with the Flash Sector Protect register. The Flash Page Select register cannot be accessed when the Flash Sector Protect register is enabled.

Table 118. Flash Page Select Register (FPS)

BITS	7	6	5	4	3	2	1	0
FIELD	INFO_EN	PAGE						
RESET	0	000_0000B						
R/W	R/W	R/W						
ADDR	FF9H							

Bit Position	Value	Description
[7] INFO_EN	0	Information Area Enable Information Area is not selected.
	1	Information Area is selected. The Information Area is mapped into the Program Memory address space at addresses FE00H through FFFFH.
[6:0] PAGE		Page Select This 7-bit field selects the Flash memory page for Programming and Page Erase operations. Program Memory Address[15:9] = PAGE[6:0].

Flash Sector Protect Register

The Flash Sector Protect register (Table 119) protects Flash memory sectors from being programmed or erased from user code. The Flash Sector Protect register shares its Register File address with the Flash Page Select register. The Flash Sector protect register can be accessed only after writing the Flash Control register with 5Eh.

User code can only write bits in this register to 1 (bits cannot be cleared to 0 by user code).

Table 119. Flash Sector Protect Register (FPROT)

BITS	7	6	5	4	3	2	1	0
FIELD	SECT7	SECT6	SECT5	SECT4	SECT3	SECT2	SECT1	SECT0
RESET	0	0	0	0	0	0	0	0
R/W	R/W1	R/W1	R/W1	R/W1	R/W1	R/W1	R/W1	R/W1
ADDR	FF9H							

Note: R/W1 = Register is accessible for Read operations. Register can be written to 1 only (through user code).

Bit Position	Value	Description
[7:0] SECT _n	0	Sector Protect Sector <i>n</i> can be programmed or erased from user code.
	1	Sector <i>n</i> is protected and cannot be programmed or erased from user code.

Flash Frequency High and Low Byte Registers

The Flash Frequency High and Low Byte registers (Table 120 and Table 121) combine to form a 16-bit value (FFREQ) to control timing for Flash program and erase operations.

The 16-bit Flash Frequency registers must be written with the system clock frequency in kHz for Program and Erase operations.

Calculate the Flash Frequency value using the following equation:

$$\text{FFREQ}[15:0] = \{\text{FFREQH}[7:0], \text{FFREQL}[7:0]\} = \frac{\text{System Clock Frequency}}{1000}$$



Caution: *Flash programming and erasure is not supported for system clock frequencies below 32 kHz, above 20 MHz, or outside the valid operating frequency range for the device. The Flash Frequency High and Low Byte registers must be loaded with the correct value to ensure proper program and erase times.*

Table 120. Flash Frequency High Byte Register (FFREQH)

BITS	7	6	5	4	3	2	1	0
FIELD	FFREQH							
RESET	00H							
R/W	R/W							
ADDR	FFAH							

Table 121. Flash Frequency Low Byte Register (FFREQL)

BITS	7	6	5	4	3	2	1	0
FIELD	FFREQL							
RESET	00H							
R/W	R/W							
ADDR	FFBH							

FFREQH and FFREQL—Flash Frequency High and Low Bytes

These 2 bytes, {FFREQH[7:0], FFREQL[7:0]}, contain the 16-bit Flash Frequency value.



Option Bits

Option bits allow user configuration of certain aspects of the Z8FMC16100 Series Flash MCU operation. The feature configuration data is stored in program memory and read during Reset.

The features available for control using the option bits include:

- Watchdog Timer (WDT) timeout selection of interrupt or Reset
- Watchdog Timer enabled at Reset
- Code protection by preventing external read access of program memory
- Ability to prevent accidental programming and erasure of program memory
- Voltage Brownout (VBO) can be disabled during STOP mode to reduce power consumption
- External oscillator mode selection
- Selectable PWM OFF state, output polarity, fault state, and Reset state
- Disable PWM output pairs, enabling them as inputs
- $\overline{\text{RESET}}$ /Fault0 pin function selection
- Low power clock divide mode selection

Option Bit Types

Two types of option bits (**user option** and **trim option bits**) allow configuration of certain aspects of Z8FMC16100 Series Flash MCU operation. Each is described in the following sections:

- [User Option Bits](#)
- [Trim Option Bits](#)

User Option Bits

The user option bits are contained in the first two bytes of program memory. As these locations contain application-specific device configuration, you can alter these bytes by programming Flash memory.

► **Note:** *The information in these bytes is lost when Page 0 of program memory is erased.*

Trim Option Bits

The trim option bits are contained in the information page of Flash memory. These bits are factory-programmed values required to optimize the operation of on-board analog circuitry, and cannot be altered by the user. Program memory can be erased without endangering these values.



Caution: *It is possible to alter the working values of these bits by accessing the Trim Bit Address and Data registers, but these working values are lost after a Reset.*

There are 32 trim addresses. To read or write these values, the user code must first write a value between 00h and 1Fh into the Trim Bit Address register. Writing the Trim Bit Data register changes the working value of the target trim data. Reading the Trim Bit Data register returns the working value of the target trim data.

User Option Bit Configuration By Reset

Each time the user option bits are programmed or erased, the device must be Reset for the change to take place.

Option Bit Address Space

The first two bytes of program memory at addresses 0000h ([Table 122](#)) and 0001h, ([Table 123](#)) are reserved for the user option bits.

Program Memory Address 0000H

Table 122. User Option Bits at Program Memory Address 0000H

BITS	7	6	5	4	3	2	1	0
FIELD	WDT_RES	WDT_AO	OSC_SEL[1:0]		VBO_AO	RP	Reserved	FWP
RESET	U	U	U		U	U	U	U
R/W	R/W	R/W	R/W		R/W	R/W	R/W	R/W
ADDR	Program Memory 0000H							
Note: U = Unchanged by Reset. R/W = Read/Write.								

Bit Position	Value (H)	Description
[7] WDT_RES	0	Watchdog Timer Reset Watchdog Timer timeout generates an interrupt request. Interrupts must be globally enabled for the eZ8 CPU to acknowledge the interrupt request.
	1	Watchdog Timer timeout causes a Reset.
[6] WDT_AO	0	Watchdog Timer Always On Watchdog Timer is automatically enabled.
	1	Watchdog Timer is enabled on execution of the WDT instruction.
[5:4] OSC_SEL	00	External Oscillator Mode Selection Reserved.
	01	Minimum power for use with very low frequency crystals (32 kHz to 1.0 MHz).
	10	Medium power for use with medium frequency crystals or ceramic resonators (0.5 MHz to 10.0 MHz).
	11	Maximum power for use with high frequency crystals (8.0 MHz to 20.0 MHz).
[3] VBO_AO	0	Voltage Brownout Always On Voltage Brownout Protection is disabled in STOP mode to reduce total power consumption.
	1	Voltage Brownout Protection is always enabled.
[2] RP	0	Read Protect External access to User program code is disabled.
	1	User program code is accessible.
[1] Reserved		Must be 1. This Option Bit is reserved for future use and must always be 1.
[0] FWP	0	Flash Write Protect Programming, Page Erase, and Mass Erase using User Code is disabled.
	1	Programming, Page Erase, and Mass Erase are enabled for all of Flash Program Memory.

Program Memory Address 0001H

These bits define the PWM behavior. The High and Low default off-state (the output polarity) is also defined here. The off-state is used by the PWM output control and PWM Fault logic. PWM output pairs can be disabled and used as high-impedance input pins. The RESET/Fault0 pin function is also selectable.

Table 123. Options Bits at Program Memory Address 0001H

BITS	7	6	5	4	3	2	1	0
FIELD	FLTSEL	LPDEN	Reserved	PWM2EN	PWM1EN	PWM0EN	PWMHI	PWMLO
RESET	U	U	U	U	U	U	U	U
R/W	R/W	R/W	R/W	R/W	R/W	R/W	R/W	R/W
ADDR	Program Memory 0001H							

Note: U = Unchanged by Reset. R/W = Read/Write.

Bit Position	Value (H)	Description
[7] FLTSEL	0	RESET/Fault0 Select RESET/Fault0 pin is configured as Fault0 input.
	1	RESET/Fault0 pin is configured as RESET input.
[6] LPDEN	0	Low Power Divide Mode Enable. See Oscillator Control on page 229. Low Power Divide mode is enabled
	1	Low Power Divide mode is disabled
[5] Reserved		Must be 1. This Option Bit is reserved for future use and must always be 1.
[4] PWM2EN	0	PWM Output Pair PWM2 Enable PWM2 outputs are enabled and controlled by PWM logic.
	1	PWM2 outputs are always high-impedance.
[3] PWM1EN	0	PWM Output Pair PWM1 Enable PWM1 outputs are enabled and controlled by PWM logic.
	1	PWM1 outputs are always high-impedance.
[2] PWM0EN	0	PWM Output Pair PWM0 Enable PWM0 outputs are enabled and controlled by PWM logic.
	1	PWM0 outputs are always high-impedance.
[1] PWMHI	0	PWM High Side (PWM outputs 0H, 1H, 2H) Default Off-State PWM High-side inactive state is Low, active state is High.
	1	PWM High-side inactive state is High, active state is Low.
[0] PWMLO	0	PWM Low Side (PWM outputs 0L, 1L, 2L) Default Off-State PWM Low-side inactive state is Low, active state is High.
	1	PWM Low-side inactive state is High, active state is Low.

The Trim Bit Address register (Table 124) contains the target address for access to the trim option bits.

Table 124. Trim Bit Address Register (TRMADR)

BITS	7	6	5	4	3	2	1	0
FIELD	TRMADR							
RESET	00H							
R/W	R/W							
ADDR	FF6H							

Bit Position	Value (H)	Description
[7:0] TRMADR	00 - 1FH	Trim Bit Address Register

Trim Bit Data Register

The Trim Bit Data register (Table 125) contains the read or write data for access to addresses in the Trim Bit Address register.

Table 125. Trim Bit Data Register (TRMDR)

BITS	7	6	5	4	3	2	1	0
FIELD	TRMDR							
RESET	00H							
R/W	R/W							
ADDR	FF7H							

Bit Position	Value (H)	Description
[7:0] TRMDR	00 - FFH	Trim Bit Data Register

Trim Bit Address 0001H

This register is loaded from the Flash Information Area following reset or STOP mode recovery. Write to this register allows user frequency adjustment of the IPO. Writing to this register does not effect the Flash memory contents.

Table 126. IPO Trim Option Bits at 0001H (IPO_TRIM)

BITS	7	6	5	4	3	2	1	0
FIELD	TEMP_TRIM						IPO_TRIM[9:8]	
RESET	U							
R/W	R/W							
ADDR	Information Page Memory 0021H							
Note: U = Unchanged by Reset. R/W = Read/Write.								

Bit Position	Value (H)	Description
TEMP_TRIM [5:0]	00 - 3FH	Internal precision Oscillator trim bits for Temperature compensation.
IPO_TRIM [9:8]	00 - 11H	Internal Precision Oscillator Trim Byte Used with IPO Trim1 options bits as bits [9:8]. Trimming for Internal Precision Oscillator frequency adjustment.

Trim Bit Address 0002H

This register is loaded from the Flash Information Area following reset or STOP mode recovery. Writing to this register allows user frequency adjustment of the IPO. Writing to this register does not effect the Flash memory contents.

Table 127. IPO Trim1 Option Bits at 0002H (IPO_TRIM1)

BITS	7	6	5	4	3	2	1	0
FIELD	IPO_TRIM[7:0]							
RESET	U							
R/W	R/W							
ADDR	Information Page Memory 0022H							
Note: U = Unchanged by Reset. R/W = Read/Write.								

Bit Position	Value (H)	Description
IPO_TRIM [7:0]	00 - FFH	Internal Precision Oscillator Trim Byte Trimming byte for Internal Precision Oscillator frequency adjustment. Use with IPO trim bits [9:8] in previous register.

Trim Bit Address 0003H

Table 128. Trim Option Bits at 0004H (ADCCAL)

BITS	7	6	5	4	3	2	1	0
FIELD	Reserved			Vref_TRIM				
RESET	U							
R/W	R/W							
ADDR	Information Page Memory 0023H							
Note: U = Unchanged by Reset. R/W = Read/Write.								

Vref_TRIM—Trim values for the Vref circuit used by the Analog-to-Digital Converter (ADC) contains factory trimmed values for Vref (ADC Reference Voltage) These values are used to set the Vref voltage to meet specified tolerance. The format is TBD.



Oscillator Control

The Z8FMC16100 Series Flash MCU uses three possible clocking schemes, each user-selectable:

- Trimmable internal precision oscillator
- On-chip oscillator using off-chip crystal/resonator or external clock driver
- On-chip low precision Watchdog Timer oscillator

In addition, Z8FMC16100 Series Flash MCUs contain clock failure detection and recovery circuitry, allowing continued operation despite any potential failure of the primary oscillator.

The on-chip system clock frequency can be reduced through a clock divider allowing reduced dynamic power dissipation. Flash memory can be powered down during portions of the clock period when running slower than 10 MHz.

Operation

This section explains the logic used to select the system clock, divide down the system clock, and handle oscillator failures. For the description of specific operation of each oscillator, see [Watchdog Timer](#) on page 61, [On-Chip Oscillator](#) on page 235, and [Internal Precision Oscillator](#) on page 237.

System Clock Selection

The oscillator control block selects from the available clocks. [Table 129](#) details each clock source and its usage.

Table 129. Oscillator Configuration and Selection

Clock Source	Characteristics	Required Setup
Internal Precision Oscillator	<ul style="list-style-type: none"> • 5.5296 MHz • High precision possible when trimmed • No external components required 	<ul style="list-style-type: none"> • This is the reset default
External Crystal/Resonator/ External Clock Drive	<ul style="list-style-type: none"> • 0 MHz to 20 MHz • Very high accuracy (dependent on crystal/resonator or external source) • Requires external components 	<ul style="list-style-type: none"> • Configure Option Bits for correct external oscillator mode • Unlock and write Oscillator Control register (OSCCTL) to enable external oscillator • Wait for 50 ms stabilization time • Unlock and write Oscillator Control register (OSCCTL) to select external oscillator
Internal Watchdog Timer Oscillator	<ul style="list-style-type: none"> • 10 kHz nominal • Low accuracy • No external components required • Low power consumption 	<ul style="list-style-type: none"> • Unlock and write Oscillator Control register (OSCCTL) to enable and select Internal WDT oscillator

Unintentional accesses to the Oscillator Control register (OSCCTL) can stop the chip by switching to a nonfunctioning oscillator. Accidental alteration of the OSCCTL register is prevented by a locking/unlocking scheme. To write the register, unlock it by two writes to the OSCCTL register with the values E7H followed by 18H. A third write to the OSCCTL register then changes the value of the register and returns the register to a locked state. Any other sequence of oscillator control register writes has no effect. The values written to unlock the register must be ordered correctly, but need not be consecutive. It is possible to access other registers within the locking/unlocking operation.

Clock Selection Following System Reset

The Internal Precision Oscillator (IPO) is selected following a System Reset. Startup code after the System Reset may change the system clock source by unlocking and configuring the OSCCTL register. If the LPDEN bit in Program Memory Address 0001H is 0, Flash Low Power mode is enabled during reset. When Flash Low Power mode is enabled during reset, the FLPEN bit in the Oscillator Control register (OSCCTL) is set and the DIV field of the OSCDIV register is set to 08h.

Clock Failure Detection and Recovery for Primary Oscillator

The Z8FMC16100 Series Flash MCU generates a System Exception, when a failure of the primary oscillator occurs, if the POFEN bit is set in the OSCCTL register. To maintain system function in this situation, the clock failure recovery circuitry automatically forces

the Watchdog Timer (WDT) oscillator to drive the system clock. Although this oscillator runs at a much lower frequency than the original system clock, the CPU continues to operate, allowing execution of a clock failure vector and software routines that either remedy the oscillator failure or issue a failure alert. This automatic switch-over is not available if the WDT is the primary oscillator.

If the system clock frequency drops below 1 kHz \pm 50%, the primary oscillator failure detection circuitry asserts. For operating frequencies below 2 kHz, do not enable the clock failure circuitry (POFEN must be deasserted in the OSCCTL register).

Clock Failure Detection and Recovery for WDT Oscillator

In the event of a WDT oscillator failure, a System Exception is issued if the WDFEN bit of the OSCCTL register is set. This event does not trigger an attendant clock switch-over, but alerts the CPU of the failure. After a WDT failure, it is no longer possible to detect a primary oscillator failure.

The WDT oscillator failure detection circuit counts system clocks while looking for a WDT clock. The logic counts 8000 system clock cycles before determining that a failure occurred. The system clock rate determines the speed at which the WDT failure can be detected. A very slow system clock results in very slow detection times. If the WDT is the primary oscillator or if the Watchdog Timer oscillator is disabled, deassert the WDFEN bit of the OSCCTL register.

Oscillator Control Register

The Oscillator Control register (OSCCTL) enables/disables the various oscillator circuits, enables/disables the failure detection/recovery circuitry, actively powers down the flash, and selects the primary oscillator, which becomes the system clock.

The Oscillator Control register must be unlocked before writing. Writing the two-step sequence E7H followed by 18H to the Oscillator Control register address unlocks it. The register locks after completion of a register write to the OSCCTL.

Table 130. Oscillator Control Register (OSCCTL)

BITS	7	6	5	4	3	2	1	0
FIELD	INTEN	XTLEN	WDTEN	POFEN	WDFEN	FLPEN	SCKSEL	
RESET	1	0	1	0	0	0*	00	
R/W	R/W	R/W	R/W	R/W	R/W	R/W	R/W	
ADDR	F86H							
* The reset value is 1 if the option bit LPDEN is 0.								

Bit Position	Value (H)	Description
[7] INTEN	0	Internal Precision Oscillator Enable Internal precision oscillator is disabled.
	1	Internal precision oscillator is enabled.
[6] XTLEN	0	Crystal Oscillator Enable Crystal oscillator is disabled.
	1	Crystal oscillator is enabled.
[5] WDTEN	0	Watchdog Timer Oscillator Enable Watchdog Timer oscillator is disabled.
	1	Watchdog Timer oscillator is enabled.
[4] POFEN	0	Primary Oscillator Failure Detection Enable Failure detection and recovery of primary oscillator is disabled. This bit is cleared automatically if a primary oscillator failure is detected.
	1	Failure detection and recovery of primary oscillator is enabled.
[3] WDFEN	0	Watchdog Timer Oscillator Failure Detection Enable Failure detection of Watchdog Timer oscillator is disabled. This bit is cleared automatically if a Watchdog Timer oscillator failure is detected.
	1	Failure detection of Watchdog Timer oscillator is enabled.
[2] FLPEN	0	Flash Low Power Mode Enable Flash Low Power Mode is disabled.
	1	Flash Low Power Mode is enabled. The Flash is powered down during idle periods of the clock and powered up during Flash reads. This bit should only be set if the frequency of the primary oscillator source is 8 MHz or lower. The reset value of this bit is controlled by the <code>LPDEN</code> option bit during reset.
[1:0] SCKSEL	00	System Clock Oscillator Select Internal precision oscillator functions as system clock at 5.6 MHz.
	01	Crystal oscillator or external clock driver functions as system clock .
	10	Reserved.
	11	Watchdog Timer oscillator functions as system clock.

Oscillator Divide Register

The Oscillator Divide register (OSCDIV) provides the value that divides the system clock. The Oscillator Divide register must be unlocked before writing. Writing the two-step sequence `E7h`, followed by `18h`, to the Oscillator Control register address unlocks the register. The register locks after completion of a register Write to the OSCDIV.

Table 131. Oscillator Divide Register (OSCDIV)

BITS	7	6	5	4	3	2	1	0
FIELD	DIV							
RESET	00H*							
R/W	R/W							
ADDR	F87H							

* The reset value is 08H if the option bit LPDEN is 0.

Bit Position	Value (H)	Description
[7:0]		Oscillator Divide
DIV	00H to FFH	00H—divider is disabled, all other entries are the divide value for scaling the system clock.



On-Chip Oscillator

The products in the Z8FMC16100 Series Flash MCU features an on-chip oscillator for use with external crystals with frequencies ranging from 32 kHz to 20 MHz. In addition, the oscillator supports ceramic resonators with oscillation frequencies up to 20 MHz. This oscillator generates the primary system clock for the internal eZ8 CPU and the majority of the on-chip peripherals. Alternatively, the X_{IN} input pin can also accept a CMOS-level clock input signal (32 kHz to 20 MHz). If an external clock generator is used, the X_{OUT} pin must remain unconnected.

When configured for use with crystal oscillators or external clock drivers, the frequency of the signal on the X_{IN} input pin determines the frequency of the system clock (that is, no internal clock divider).

Crystal Oscillator Operation

Figure 40 displays a recommended configuration for connection with an external fundamental-mode, parallel-resonant crystal operating at 20 MHz. Recommended 20 MHz crystal specifications are provided in Table 132. The printed circuit board layout must add no more than 4 pF of stray capacitance to either the X_{IN} or X_{OUT} pins. If oscillation does not occur, reduce the values of capacitors C1 and C2 to decrease loading.

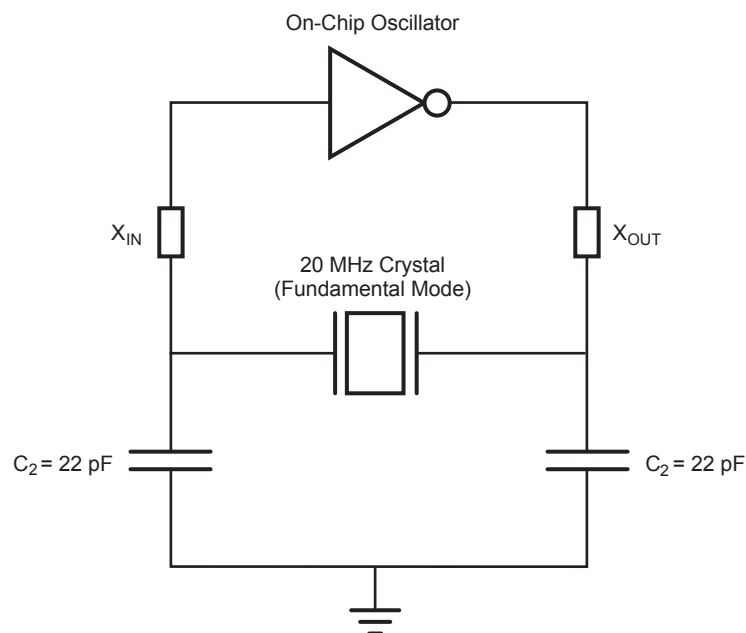

Figure 40. Recommended 20 MHz Crystal Oscillator Configuration

Table 132. Recommended Crystal Oscillator Specifications (20 MHz Operation)

Parameter	Value	Units	Comments
Frequency	20	MHz	
Resonance	Parallel		
Mode	Fundamental		
Series Resistance (R_S)	25	Ohm	Maximum
Load Capacitance (C_L)	20	pF	Maximum
Shunt Capacitance (C_0)	7	pF	Maximum
Drive Level	1	mW	Minimum

Internal Precision Oscillator

The Internal Precision Oscillator (IPO) is designed for use without external components. The IPO comes factory trimmed a $\pm 4\%$ frequency accuracy over the operating temperature and supply voltage range of the device.

The IPO features include:

- On-chip RC oscillator that does not require external components.
- Trimmed to $\pm 4\%$ accuracy.
- Target output frequency of 5.5296 MHz.
- Trimming possible through Flash option bits with user override.
- IPO can eliminate crystals or ceramic resonators in applications where high timing accuracy is not required.

Operation

The internal oscillator is an RC relaxation oscillator which has its sensitivity to power supply variation minimized. By using ratio tracking thresholds, the effect of power supply voltage is cancelled out. The dominant source of oscillator error is the absolute variance of chip-level fabricated components, such as capacitors. Two 8-bit trimming registers, incorporated into the design, allow compensation of absolute variation of oscillator frequency. Once calibrated, the oscillator frequency is relatively stable and does not require subsequent calibration.

By default, the oscillator is configured through the Flash Option bits. However, the user code can override these trim values as described in [Trim Option Bits](#) on page 222.



On-Chip Debugger

The Z8FMC16100 Series Flash MCU device includes an integrated on-chip debugger (OCD) that provides advanced debugging features, including:

- Reading and writing of the Register File
- Reading and writing of program and data memory
- Setting of break points
- Execution of eZ8 CPU instructions

Architecture

The OCD consists of four primary functional blocks: **Transmitter**, **Receiver**, **Autobaud Generator**, and **Debug Controller**. Figure 41 displays the architecture of the OCD.

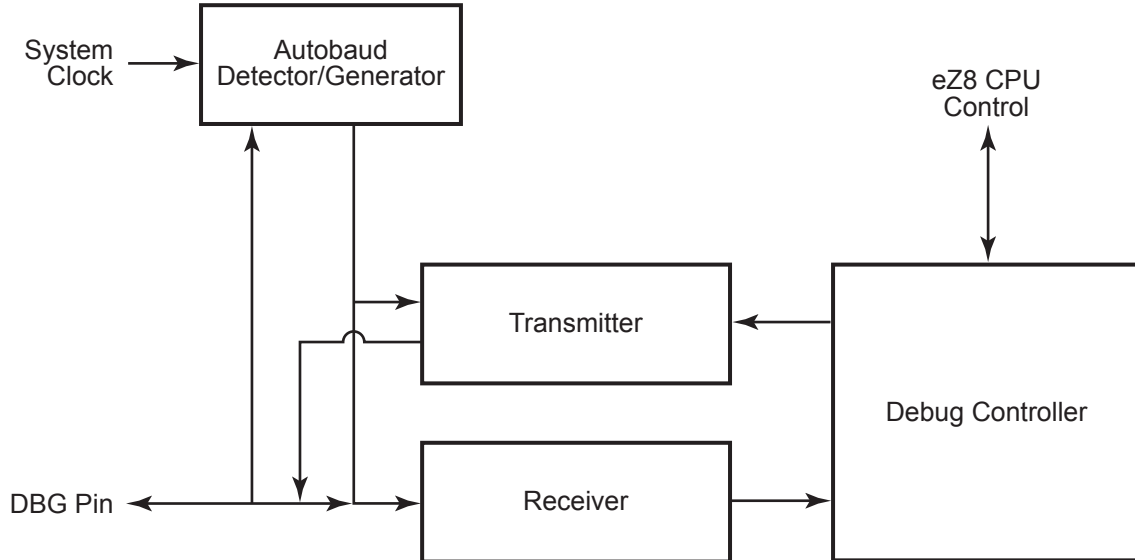

Figure 41. On-Chip Debugger Block Diagram

OCD Interface

The OCD uses the DBG pin for communication with an external host. This one-pin interface is a bidirectional open-drain interface that transmits and receives data. Data transmission is half-duplex, in that transmit and receive cannot occur simultaneously.

The serial data on the DBG pin is sent using the standard asynchronous data format defined in RS-232. This pin interfaces the Z8FMC16100 Series Flash MCU device to the serial port of a host PC using minimal external hardware. Two different methods for connecting the DBG pin to an RS-232 interface are displayed in Figure 42 and Figure 43.



Caution: For operation of the Z8FMC16100 Series Flash MCU, power pins (V_{DD} and AV_{DD}) must be supplied with power, and ground pins (V_{SS} and AV_{SS}) must be properly grounded. The DBG pin must always be connected to V_{DD} through an external pull-up resistor.

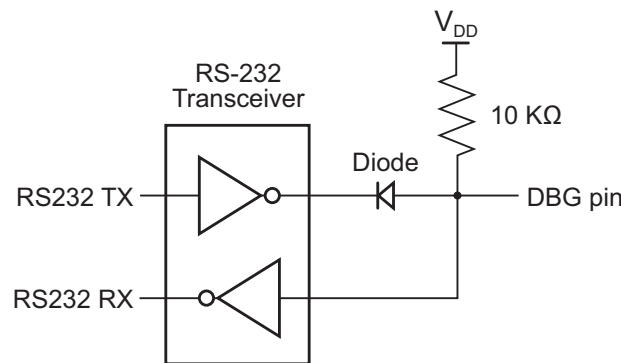

Figure 42. Interfacing the On-Chip Debugger's DBG Pin with an RS-232 Interface (1)

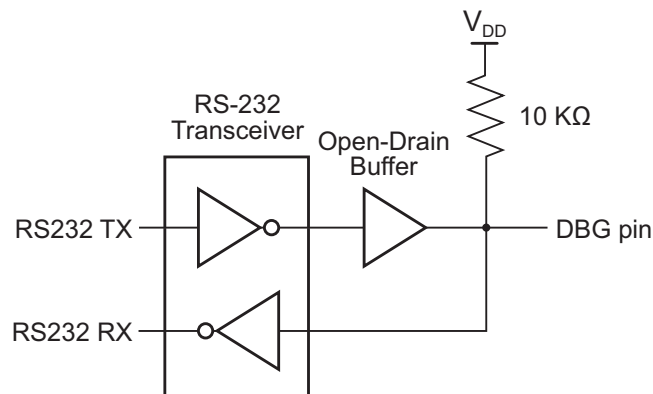

Figure 43. Interfacing the On-Chip Debugger's DBG Pin with an RS-232 Interface (2)

Debug Mode

The operating characteristics of the Z8FMC16100 Series Flash MCU device in DEBUG mode are:

- The eZ8 CPU fetch unit stops, idling the eZ8 CPU, unless directed by the OCD to execute specific instructions

- The system clock operates unless in STOP mode
- All enabled on-chip peripherals operate unless in STOP mode or otherwise defined by the on-chip peripheral to disable in DEBUG mode
- Automatically exits HALT mode
- Constantly refreshes the Watchdog Timer (if enabled)

Entering DEBUG Mode

The device enters DEBUG mode following any of the below operations:

- Writing the DBGMODE bit in the OCD Control register to 1 using the OCD interface
- eZ8 CPU execution of a BRK (break point) instruction (when enabled)
- Match of PC to OCDCNTR register (when enabled)
- OCDCNTR register decrements to 0000h (when enabled)
- The DBG pin is Low when the device exits Reset

Exiting DEBUG Mode

The device exits DEBUG mode following any of the below operations:

- Clearing the DBGMODE bit in the OCD Control register to 0
- Power-On reset
- Voltage Brownout reset
- Asserting the $\overline{\text{RESET}}$ pin Low to initiate a Reset
- Driving the DBG pin Low while the device is in STOP mode initiates a System Reset

OCD Data Format

The OCD interface uses the asynchronous data format defined for RS-232. Each character is transmitted as 1 start bit, 8 data bits (least-significant bit first), and 1 stop bit, see [Figure 44](#).

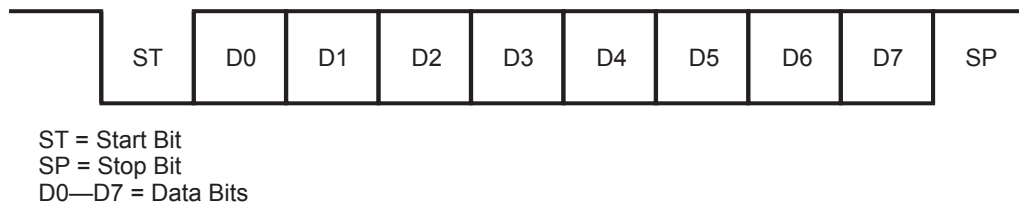

Figure 44. OCD Data Format

OCD Auto-Baud Detector/Generator

To run over a range of baud rates (bps) with various system clock frequencies, the OCD has an Auto-Baud Detector/Generator. After a reset, the OCD is idle until it receives data. The OCD requires that the first character sent from the host is the character 80h. The character 80h contains eight continuous bits Low (one Start bit plus 7 data bits). The Auto-Baud Detector measures this period and sets the OCD Baud Rate Generator accordingly.

The Auto-Baud Detector/Generator is clocked by the system clock. The minimum baud rate is the system clock frequency divided by 512. The maximum recommended baud rate is the system clock frequency divided by 8. [Table 133](#) lists minimum and recommended maximum baud rates for sample crystal frequencies.

Table 133. OCD Baud-Rate Limits

System Clock Frequency	Maximum Asynchronous Baud Rate (bps)	Minimum Baud Rate (bps)
20.0 MHz	2.5 M	39.1 K
1.0 MHz	125 K	1960
32.768 kHz	4096	64

If the OCD receives a Serial Break (ten or more continuous bits Low) the Auto-Baud Detector/Generator resets. The Auto-Baud Detector/Generator can then be reconfigured by sending 80h. If the Auto-Baud Detector overflows while measuring the Auto-Baud character, the Auto-Baud Detector will remain reset.

OCD Serial Errors

The OCD detects any of the following error conditions on the DBG pin:

- Serial Break (a minimum of ten continuous bits Low)
- Framing Error (received STOP bit is Low)
- Transmit Collision (OCD and host simultaneous transmission detected by the OCD)

When the OCD detects one of these errors, it aborts any command currently in progress, transmits a Serial Break 4096 system clock cycles long back to the host, and resets the Auto-Baud Detector/Generator. A Framing Error or Transmit Collision can be caused by the host sending a Serial Break to the OCD. Due to the open-drain nature of the interface, returning a Serial Break back to the host only extends the length of the Serial Break, if the host releases the Serial Break early.

The host transmits a Serial Break on the DBG pin when first connecting to the Z8FMC16100 Series Flash MCU device or when recovering from an error. A Serial Break from the host resets the Auto-Baud Generator/Detector but does not reset the OCD Control register. A Serial Break leaves the device in DEBUG mode if that is the current mode. The OCD is held in Reset until the end of the Serial Break when the DBG pin returns High. Due to the open-drain nature of the DBG pin, the host can send a Serial Break to the OCD even if the OCD is transmitting a character.

Automatic Reset

The Z8FMC16100 Series Flash MCU devices have the capability to switch clock sources during operation. If the Auto-Baud is set and the clock source is switched, the Auto-Baud value becomes invalid. A new Auto-Baud value must be configured with the new clock frequency.

The oscillator control logic has clock switch detection. If a clock switch is detected and the Auto-Baud is set, the device automatically sends a Serial Break for 4096 clocks. This resets the Auto-Baud and indicate to the host that a new Auto-Baud character must be sent.

Break Points

Execution break points are generated using the BRK instruction (Opcode 00h). When the eZ8 CPU decodes a BRK instruction, it signals the OCD. If break points are enabled, the OCD idles the eZ8 CPU and enters DEBUG mode. If break points are not enabled, the OCD ignores the BRK signal and the BRK instruction operates as a NOP instruction.

If break points are enabled, the OCD can be configured to automatically enter DEBUG mode, or to loop on the break instruction. If the OCD is configured to loop on the BRK instruction, then the CPU remains able to service DMA and interrupt requests.

The loop on BRK instruction can service interrupts in the background. For interrupts to be serviced in the background, there cannot be any break points in the interrupt service routine. Otherwise, the CPU stops on the break point in the interrupt routine. For interrupts to be serviced in the background, interrupts must be enabled. Debugging software does not automatically enable interrupts when using this feature. Interrupts are typically disabled during critical sections of code where interrupts do not occur (such as adjusting the stack pointer or modifying shared data).

Host software can poll the IDLE bit of the OCDSTAT register to determine if the OCD is looping on a BRK instruction. When software wants to stop the CPU on the BRK instruction on which it is looping, software must not set the DBGMODE bit of the OCDCTL register. The CPU may have vectored to an interrupt service routine. Instead, software clears the BRKLP bit. This allows the CPU to finish the interrupt service routine it may be in and return to the BRK instruction. When the CPU returns to the BRK instruction

on which it was previously looping, it automatically sets the DBGMODE bit and enters DEBUG mode.

The majority of the OCD commands remain disabled when the eZ8 CPU is looping on a BRK instruction. The eZ8 CPU must be in DEBUG mode before these commands are issued.

Break Points in Flash Memory

The BRK instruction is Opcode 00h, which corresponds to the fully programmed state of a byte in Flash memory. To implement a break point, write 00h to the appropriate address, overwriting the current instruction. To remove a break point, erase the corresponding page of Flash memory and reprogram with the original data.

OCDCNTR Register

The OCD contains a multipurpose 16-bit Counter register which can be used for the following:

- Count system clock cycles between break points
- Generate a BRK when it counts down to 0
- Generate a BRK when its value matches the Program Counter

When configured as a counter, the OCDCNTR register starts counting when the on-chip debugger leaves DEBUG mode and stops counting when it enters DEBUG mode again or when it reaches the maximum count of FFFFh. The OCDCNTR register automatically resets itself to 0000h when the OCD exits DEBUG mode, if it is configured to count clock cycles between break points.

If the OCDCNTR register is configured to generate a BRK when it counts down to zero, it will not be reset when the CPU starts running. Once the OCD exits DEBUG mode, the counter starts counting down toward zero. If the OCD enters DEBUG mode before the OCDCNTR register counts down to zero, the OCDCNTR stops counting.

If the OCDCNTR register is configured to generate a BRK when the program counter matches the OCDCNTR register, the OCDCNTR register will not be reset when the CPU resumes executing and it will not be decremented when the CPU is running. A BRK is generated when the program counter matches the value in the OCDCNTR register before executing the instruction at the location of the program counter.



Caution: *The OCDCNTR register is used by many OCD commands. It counts the number of bytes for the register and memory read/write commands. It retains the residual value when generating the CRC. If the OCDCNTR is used to generate a BRK, its value must be written as a final step before leaving DEBUG mode.*

As this register is overwritten by various OCD commands, it must only be used to generate temporary break points, such as stepping over CALL instructions or running to a specific instruction and stopping.

When the OCDCNTR register is read, it returns the inverse of the data in this register. The OCDCNTR register is only decremented when counting. The mode where it counts the number of clock cycles in between execution is achieved by counting down from its maximum count. When the OCDCNTR register is read, the counter appears to be counted up as its value is inverted. The value in this register is always inverted when it is read. If this register is used as a hardware break point, the value read from this register will be inverse of the data actually in the register.

On-Chip Debugger Commands

The host communicates to the OCD by sending OCD commands using the DBG interface. During normal operation, only a subset of the OCD commands are available. In Debug mode, all OCD commands are available unless the user code is protected by programming the Read Protect option bit (RP). The Read Protect option bit prevents the code in memory from being read out of the Z8FMC16100 Series Flash MCU device. When this option is enabled, several OCD commands are disabled. [Table 134](#) lists a summary of the OCD commands. Each OCD command is described in detail in the list following [Table 134](#). [Table 134](#) indicates the commands that operate when the device is not in DEBUG mode (normal operation) and those commands that are disabled by programming the Read Protect option bit.

Table 134. On-Chip Debugger Commands

Debug Command	Command Byte	Enabled When Not In Debug Mode?	Disabled by Read Protect Option Bit
Read Revision	00h	Yes	—
Write OCD Counter Register	01h	—	—
Read OCD Status Register	02h	Yes	—
Read OCD Counter Register	03h	—	—
Write OCD Control Register	04h	Yes	—
Read OCD Control Register	05h	Yes	—
Write Program Counter	06h	—	Disabled
Read Program Counter	07h	—	Disabled
Write Register	08h	—	Writes to on-chip peripheral registers are enabled. Writes to the on-chip RAM are disabled.

Table 134. On-Chip Debugger Commands (Continued)

Debug Command	Command Byte	Enabled When Not In Debug Mode?	Disabled by Read Protect Option Bit
Read Register	09h	—	Reads from on-chip peripheral registers are enabled. Reads from the on-chip RAM are disabled.
Write Program Memory	0Ah	—	Disabled
Read Program Memory	0Bh	—	Disabled
Write Data Memory	0Ch	—	Disabled
Read Data Memory	0Dh	—	Disabled
Read Program Memory CRC	0Eh	—	—
Reserved	0Fh	—	—
Step Instruction	10h	—	Disabled
Stuff Instruction	11H	—	Disabled
Execute Instruction	12H	—	Disabled
Read Baud Reload Register	1BH	—	—

Note: Unlisted command byte values are reserved.

In the following list of OCD Commands, data and commands sent from the host to the OCD are identified by ‘DBG ← Command/Data’. Data sent from the OCD back to the host is identified by ‘DBG → Data’

Read Revision—The Read Revision command returns the revision identifier.

DBG ← 00h
 DBG → REVID[15:8] (Major revision number)
 DBG → REVID[7:0] (Minor revision number)

Write OCD Counter Register—The Write OCD Counter register command writes the data that follows to the OCDCNTR register. If the device is not in DEBUG mode, the data is discarded.

DBG ← 01h
 DBG ← OCDCNTR[15:8]
 DBG ← OCDCNTR[7:0]

Read OCD Status Register—The Read OCD Status register command reads the OCDSTAT register.

```
DBG ← 02h
DBG → OCDSTAT [7:0]
```

Read OCD Counter Register—The OCD Counter register can be used to count system clock cycles in between break points, generate a BRK when it counts down to 0, or generate a BRK when its value matches the Program Counter. As this register is a down counter, the returned value is inverted, when this register is read so the returned result appears to be an up counter. If the device is not in DEBUG mode, this command returns FFFFh.

```
DBG ← 03h
DBG → ~OCDCNTR [15:8]
DBG → ~OCDCNTR [7:0]
```

Write OCD Control Register—The Write OCD Control register command writes the data that follows to the OCDCTL register.

```
DBG ← 04h
DBG ← OCDCTL [7:0]
```

Read OCD Control Register—The Read OCD Control register command reads the value of the OCDCTL register.

```
DBG ← 05h
DBG → OCDCTL [7:0]
```

Write Program Counter—The Write Program Counter command writes the data that follows to the eZ8 CPU's Program Counter (PC). If the device is not in DEBUG mode or if the Read Protect option bit is enabled, the PC values are discarded.

```
DBG ← 06h
DBG ← ProgramCounter [15:8]
DBG ← ProgramCounter [7:0]
```

Read Program Counter—The Read Program Counter command reads the value in the eZ8 CPU's Program Counter. If the device is not in DEBUG mode or if the Read Protect option bit is enabled, this command returns FFFFh.

```
DBG ← 07h
DBG → ProgramCounter [15:8]
DBG → ProgramCounter [7:0]
```

Write Register—The Write register command writes data to the Register File. Data can be written 1-256 bytes at a time (256 bytes are written by setting size to zero). If the device is not in DEBUG mode, the address and data values are discarded. If the Read Protect option bit is enabled, then only writes to the on-chip peripheral registers are allowed and all other register write data values are discarded.

```
DBG ← 08h
DBG ← {4'h0, Register Address[11:8]}
DBG ← Register Address[7:0]
DBG ← Size[7:0]
DBG ← 1-256 data bytes
```

Read Register—The Read register command reads data from the Register File. Data can be read 1-256 bytes at a time (256 bytes can be read by setting size to zero). If the device is not in DEBUG mode or if the Read Protect option bit is enabled and on-chip RAM is being read from, this command returns FFh for all the data values.

```
DBG ← 09h
DBG ← {4'h0, Register Address[11:8]}
DBG ← Register Address[7:0]
DBG ← Size[7:0]
DBG → 1-256 data bytes
```

Write Program Memory—The Write Program Memory command writes data to Program Memory. This command is equivalent to the LDC and LDCI instructions. Data can be written 1-65536 bytes at a time (65536 bytes can be written by setting size to 0). The on-chip Flash controller must be written to and unlocked for the programming operation to occur. If the Flash controller is not unlocked, the data is discarded. If the device is not in DEBUG mode or if the Read Protect option bit is enabled, the data is discarded.

```
DBG ← 0Ah
DBG ← Program Memory Address[15:8]
DBG ← Program Memory Address[7:0]
DBG ← Size[15:8]
DBG ← Size[7:0]
DBG ← 1-65536 data bytes
```

Read Program Memory—The Read Program Memory command reads data from Program Memory. This command is equivalent to the LDC and LDCI instructions. Data can be read 1 to 65536 bytes at a time (65536 bytes can be read by setting size to 0). If the device is not in DEBUG mode or if the Read Protect option bit is enabled, this command returns FFh for the data.

```
DBG ← 0Bh
DBG ← Program Memory Address[15:8]
DBG ← Program Memory Address[7:0]
```

```
DBG ← Size[15:8]
DBG ← Size[7:0]
DBG → 1-65536 data bytes
```

Write Data Memory—The Write Data Memory command writes data to Data Memory. This command is equivalent to the LDE and LDEI instructions. Data can be written 1 to 65536 bytes at a time (65536 bytes can be written by setting size to 0). If the device is not in DEBUG mode or if the Read Protect option bit is enabled, the data is discarded.

```
DBG ← 0Ch
DBG ← Data Memory Address[15:8]
DBG ← Data Memory Address[7:0]
DBG ← Size[15:8]
DBG ← Size[7:0]
DBG ← 1-65536 data bytes
```

Read Data Memory—The Read Data Memory command reads from Data Memory. This command is equivalent to the LDE and LDEI instructions. Data can be read 1 to 65536 bytes at a time (65536 bytes can be read by setting size to 0). If the device is not in DEBUG mode, this command returns FFh for the data.

```
DBG ← 0Dh
DBG ← Data Memory Address[15:8]
DBG ← Data Memory Address[7:0]
DBG ← Size[15:8]
DBG ← Size[7:0]
DBG → 1-65536 data bytes
```

Read Program Memory CRC—The Read Program Memory CRC command computes and returns the CRC (cyclic redundancy check) of Program Memory using the 16-bit CRC-CCITT polynomial ($x^{16} + x^{12} + x^5 + 1$). The CRC is preset to all 1s. The least-significant bit of the data is shifted through the polynomial first. The CRC is inverted when it is transmitted. If the device is not in DEBUG mode, this command returns FFFFh for the CRC value. Unlike most other OCD Read commands, there is a delay from issuing of the command until the OCD returns the data. The OCD reads the Program Memory, calculates the CRC value, and returns the result. The delay is a function of the Program Memory size and is approximately equal to the system clock period multiplied by the number of bytes in the Program Memory.

```
DBG ← 0Eh
DBG → CRC[15:8]
DBG → CRC[7:0]
```

Step Instruction—The Step Instruction command steps one assembly instruction at the current Program Counter location. If the device is not in DEBUG mode or the Read Protect option bit is enabled, the OCD ignores this command.

DBG ← 10h

Stuff Instruction—The Stuff Instruction command steps one assembly instruction and allows specification of the first byte of the instruction. The remaining 0 to 4 bytes of the instruction are read from Program Memory. This command is useful for stepping over instructions where the first byte of the instruction has been overwritten by a break point. If the device is not in DEBUG mode or the Read Protect option bit is enabled, the OCD ignores this command.

DBG ← 11h

DBG ← opcode [7:0]

Execute Instruction—The Execute Instruction command allows sending an entire instruction to be executed to the eZ8 CPU. This command can also step over break points. The number of bytes to send for the instruction depends on the Opcode. If the device is not in DEBUG mode or the Read Protect option bit is enabled, the OCD ignores this command.

DBG ← 12h

DBG ← 1-5 byte opcode

Read Baud Reload Register—The Read Baud Reload register command returns the current value in the Baud Reload register.

DBG ← 1Bh

DBG → BAUD [15:8]

DBG → BAUD [7:0]

OCD Control Register

The OCD Control register (see [Table 135](#) on page 251) controls the state of the on-chip debugger. This register enters or exits DEBUG mode and enables the BRK instruction. It can also reset the Z8FMC16100 Series Flash MCU.

A *reset and stop* function can be achieved by writing 81H to this register. A *reset and go* function is achieved by writing 41H to this register. If the device is in DEBUG mode, a *run* function is implemented by writing 40h to this register.

A more detailed description of each bit follows [Table 135](#).

Table 135. OCD Control Register (OCDCTL)

BITS	7	6	5	4	3	2	1	0
FIELD	DBGMODE	BRKEN	DBGACK	BRKLOOP	BRKPC	BRKZRO	Reserved	RST
RESET	0	0	0	0	0	0	0	0
R/W	R/W	R/W	R/W	R	R/W	R/W	R/W	R/W

DBGMODE—Debug Mode

Setting this bit to 1 causes the device to enter DEBUG mode. When in DEBUG mode, the eZ8 CPU stops fetching new instructions. Clearing this bit causes the eZ8 CPU to resume execution. This bit is automatically set when a BRK instruction is decoded and Breakpoints are enabled.

0 = The device is running (operating in NORMAL mode).

1 = The device is in DEBUG mode.

BRKEN—Breakpoint Enable

This bit controls the behavior of the BRK instruction (opcode 00H). By default, Breakpoints are disabled and the BRK instruction behaves like a NOP. If this bit is set to 1 and a BRK instruction is decoded, the OCD takes action dependent upon the BRKLOOP bit.

0 = BRK instruction is disabled.

1 = BRK instruction is enabled.

DBGACK—Debug Acknowledge

This bit enables the debug acknowledge feature. If this bit is set to 1, then the OCD sends a Debug Acknowledge character (FFH) to the host when a Breakpoint occurs. This bit automatically clears itself when an acknowledge character is sent.

0 = Debug Acknowledge is disabled.

1 = Debug Acknowledge is enabled.

BRKLOOP—Breakpoint Loop

This bit determines what action the OCD takes when a BRK instruction is decoded and breakpoints are enabled (BRKEN is 1). If this bit is 0, the DBGMODE bit is automatically set to 1 and the OCD enters DEBUG mode. If BRKLOOP is set to 1, the eZ8 CPU loops on the BRK instruction.

0 = BRK instruction sets DBGMODE to 1.

1 = eZ8 CPU loops on BRK instruction.

BRKPC—Break when PC == OCDCNTR

If this bit is set to 1, then the OCDCNTR register is used as a hardware breakpoint. When the program counter matches the value in the OCDCNTR register, DBGMODE is automatically set to 1. If this bit is set, the OCDCNTR register does not count when the CPU is running.

0 = OCDCNTR is setup as counter
1 = OCDCNTR generates hardware break when PC == OCDCNTR

BRKZRO—Break when OCDCNTR == 0000H

If this bit is set, then the OCD automatically sets the DBGMODE bit when the OCDCNTR register counts down to 0000H. If this bit is set, the OCDCNTR register is not reset when the part leaves DEBUG Mode.

0 = OCD does not generate BRK when OCDCNTR decrements to 0000H
1 = OCD sets DBGMODE to 1 when OCDCNTR decrements to 0000H

Reserved—Must be 0.

RST—Reset

Setting this bit to 1 resets the device. The controller goes through a normal POR sequence with the exception that the OCD is not reset. This bit is automatically cleared to 0 when the reset finishes.

0 = No effect.
1 = Reset the device.

OCD Status Register

The OCD Status register (Table 136) reports status information about the current state of the debugger and the system.

Table 136. OCD Status Register (OCDSTAT)

BITS	7	6	5	4	3	2	1	0
FIELD	IDLE	HALT	RPEN	Reserved				
RESET	0	0	0	0				
R/W	R	R	R	R				

IDLE—CPU idle

This bit is set if the part is in DEBUG mode (DBGMODE is 1) or if a BRK instruction has occurred since the last time OCDCTL was written. This can be used to determine if the CPU is running or if it is idle.

0 = The eZ8 CPU is running.
1 = The eZ8 CPU is either stopped or looping on a BRK instruction.

HALT—HALT Mode

0 = The device is not in HALT mode.
1 = The device is in HALT mode.

RPEN—Read Protect Option Bit Enabled

0 = The Read Protect Option Bit is disabled (Flash option bit is 1).

1 = The Read Protect Option Bit is enabled (Flash option bit is 0), disabling many OCD commands.

Reserved—Must be 0.

Baud Reload Register

The Baud Reload register (Table 137) contains the measured Autobaud value.

Table 137. Baud Reload Register

BITS	15	14	13	12	11	10	9	8	7	6	5	4	3	2	1	0
FIELD	Reserved				RELOAD											
RESET	0H				000H											
R/W	R				R											

RELOAD—Baud Reload Value

This value is the measured Auto-Baud value. This value is calculated using the following formula:

$$\text{RELOAD} = \frac{\text{SYSCLK}}{\text{BAUDRATE}} \times 8$$



Electrical Characteristics

The electrical characteristics of the Z8FMC16100 Series are described in the following sections.

Absolute Maximum Ratings

The ratings listed in [Table 138](#) are stress ratings only. Operation of the device at any condition outside as indicated in the operational sections of these specifications is not implied. Exposure to absolute maximum rating conditions for extended periods may affect device reliability. For improved reliability, unused inputs must be tied to one of the supply voltages (V_{DD} or V_{SS}).



Caution: Stresses greater than those listed in [Table 138](#) may cause permanent damage to the device.

Table 138. Absolute Maximum Ratings*

Parameter	Minimum	Maximum	Units	Notes
Ambient temperature under bias	-40	+105	°C	
Storage temperature	-65	+150	°C	
Voltage on PA3, PA4, PA5, PA6, and PA7 pins with respect to V_{SS}	-0.3	+5.5	V	1
Voltage on all of Port B, PA0, PA1, PA2, PC0, RESET, DBG, X_{IN} , V_{DD} and AV_{DD} pins with respect to V_{SS}	-0.3	+3.6	V	
Maximum current on input and/or inactive output pin	-5	+5	μA	
Maximum output current from digital active output pin	-25	+25	mA	
Maximum output current from digital active output pin	-5	+5	mA	
32-pin LQFP Package Maximum Ratings at -40 °C to 70 °C				
Total power dissipation		811	mW	
Maximum current into V_{DD} or out of V_{SS}		225	mA	
32-pin LQFP Package Maximum Ratings at 70 °C to 105 °C				
Total power dissipation		295	mW	
Maximum current into V_{DD} or out of V_{SS}		82	mA	

Table 138. Absolute Maximum Ratings* (Continued)

Parameter	Minimum	Maximum	Units	Notes
32-pin QFN Package Maximum Ratings at –40 °C to 70 °C				
Total power dissipation		1580	mW	
Maximum current into V_{DD} or out of V_{SS}		439	mA	
32-pin QFN Package Maximum Ratings at 70 °C to 105 °C				
Total power dissipation		575	mW	
Maximum current into V_{DD} or out of V_{SS}		160	mA	

DC Characteristics

Table 139 lists the DC characteristics of the Z8FMC16100 Series Flash MCU products. All voltages are referenced to V_{SS} , the primary system ground.

Table 139. DC Characteristics

Symbol	Parameter	$T_A = -40\text{ °C to }105\text{ °C}$			Units	Conditions
		Minimum	Typical ²	Maximum		
V_{DD}	Supply Voltage	2.7	—	3.6	V	
V_{IL1}	Low Level Input Voltage	–0.3	—	$0.3 \cdot V_{DD}$	V	For all input pins except \overline{RESET} , DBG, and X_{IN} .
V_{IL2}	Low Level Input Voltage	–0.3	—	$0.2 \cdot V_{DD}$	V	For \overline{RESET} , DBG, and X_{IN} .
V_{IH1}	High Level Input Voltage	$0.7 \cdot V_{DD}$	—	5.5	V	PA3, PA4, PA5, PA6, and PA7 pins when their programmable pull-ups are disabled.
V_{IH2}	High Level Input Voltage	$0.7 \cdot V_{DD}$	—	$V_{DD} + 0.3$	V	PA3, PA4, PA5, PA6, and PA7 pins when their programmable pull-ups are enabled. All of Port B, PA0, PA1, PA2 and PC0 pins.
V_{IH3}	High Level Input Voltage	$0.8 \cdot V_{DD}$	—	$V_{DD} + 0.3$	V	\overline{RESET} , DBG, and X_{IN} pins.

Table 139. DC Characteristics (Continued)

Symbol	Parameter	$T_A = -40\text{ °C to }105\text{ °C}$			Units	Conditions
		Minimum	Typical ²	Maximum		
V_{OL1}	Low Level Output Voltage	—	—	0.4	V	$I_{OL} = 2\text{ mA}$; $V_{DD} = 3.0\text{ V}$ High Output Drive disabled.
V_{OH1}	High Level Output Voltage	2.4	—	—	V	$I_{OH} = -2\text{ mA}$; $V_{DD} = 3.0\text{ V}$ High Output Drive disabled
V_{OL2}	Low Level Output Voltage High Drive	—	—	0.6	V	$I_{OL} = 20\text{ mA}$; $V_{DD} = 3.3\text{ V}$ High Output Drive enabled; $T_A = -40\text{ °C to }+70\text{ °C}$
V_{OH2}	High Level Output Voltage High Drive	2.4	—	—	V	$I_{OH} = -20\text{ mA}$; $V_{DD} = 3.3\text{ V}$; High Output Drive enabled; $T_A = -40\text{ °C to }+70\text{ °C}$
V_{OL3}	Low Level Output Voltage High Drive	—	—	0.6	V	$I_{OL} = 15\text{ mA}$; $V_{DD} = 3.3\text{ V}$ High Output Drive enabled; $T_A = +70\text{ °C to }+105\text{ °C}$.
V_{OH3}	High Level Output Voltage High Drive	2.4	—	—	V	$I_{OH} = 15\text{ mA}$; $V_{DD} = 3.3\text{ V}$ High Output Drive enabled; $T_A = +70\text{ °C to }+105\text{ °C}$.
V_{RAM}	RAM Data Retention	0.7	—	—	V	—
I_{IL}	Input Leakage Current	-5	—	+5	μA	$V_{DD} = 3.3\text{ V}$; $V_{IN} = V_{DD}$ or V_{SS}^1 .
I_{TL}	Tri-State Leakage Current	-5	—	+5	μA	$V_{DD} = 3.3\text{ V}$.
I_{PU1}	Weak Pull-up Current	9	20	50	μA	$V_{DD} = 2.7\text{--}3.6\text{ V}$. $T_A = 0\text{ °C to }+70\text{ °C}$.
I_{PU2}	Weak Pull-up Current	7	20	75	μA	$V_{DD} = 2.7\text{--}3.6\text{ V}$. $T_A = -40\text{ °C to }+105\text{ °C}$.
I_{dd} ACTIVE	ACTIVE mode device current		22	38	mA	MAX: 20 MHz CLK, max temp, max Vdd TYP: 25 °C, Vdd nom, 20 MHz

Table 139. DC Characteristics (Continued)

Symbol	Parameter	$T_A = -40\text{ }^\circ\text{C to } 105\text{ }^\circ\text{C}$			Units	Conditions
		Minimum	Typical ²	Maximum		
I _{dd} HALT	HALT mode device current		8	12	mA	MAX: 20 MHz CLK, max temp, max V _{dd} TYP: 25 °C, V _{dd} nom, 20 MHz
I _{dd} STOP 1	Chip leakage current in STOP mode		2	15	uA	MAX: VBO disabled, WDT enabled, max V _{dd} , max temp TYP: 25 °C, V _{dd} nom
I _{dd} STOP 2	Chip leakage current in STOP mode		<1	15	uA	MAX: VBO and WDT disabled, max V _{dd} , max temp TYP: 25 °C, V _{dd} nom

Notes

1. This condition excludes all pins that have on-chip pull-ups, when driven Low.
2. These values are provided for design guidance only and are not tested in production.

Figure 45 displays the active mode current consumption while operating at 25 °C, 3.3 V, versus the system clock frequency. All GPIO pins are configured as outputs and driven High.

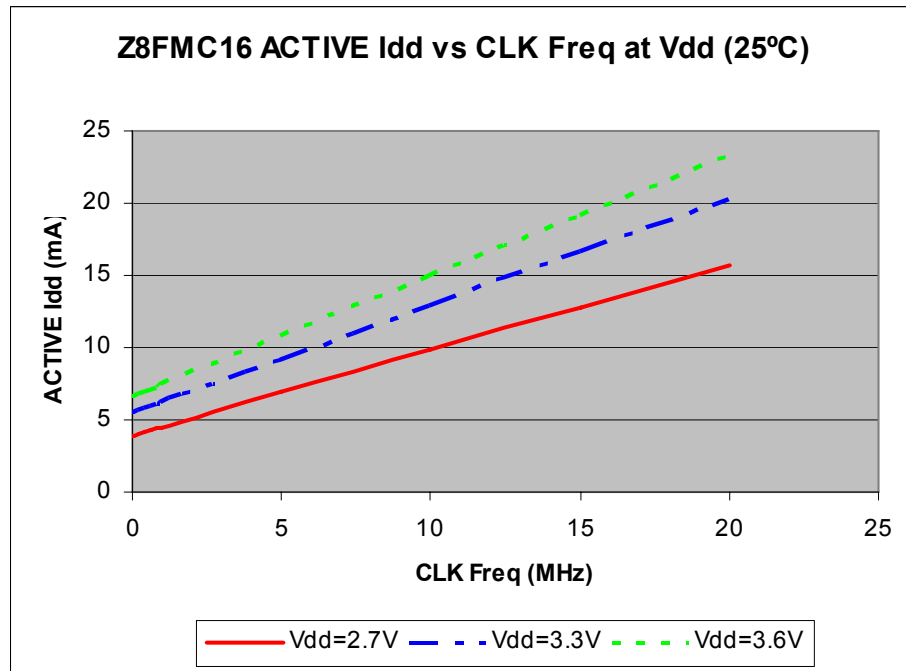

Figure 45. ACTIVE Mode Current Consumption as a Function of Clock Frequency with V_{dd} as Parameter at 25 °C

Figure 46 displays the current consumption in HALT mode while operating at 25 °C versus the system clock frequency. All GPIO pins are configured as outputs and driven High.

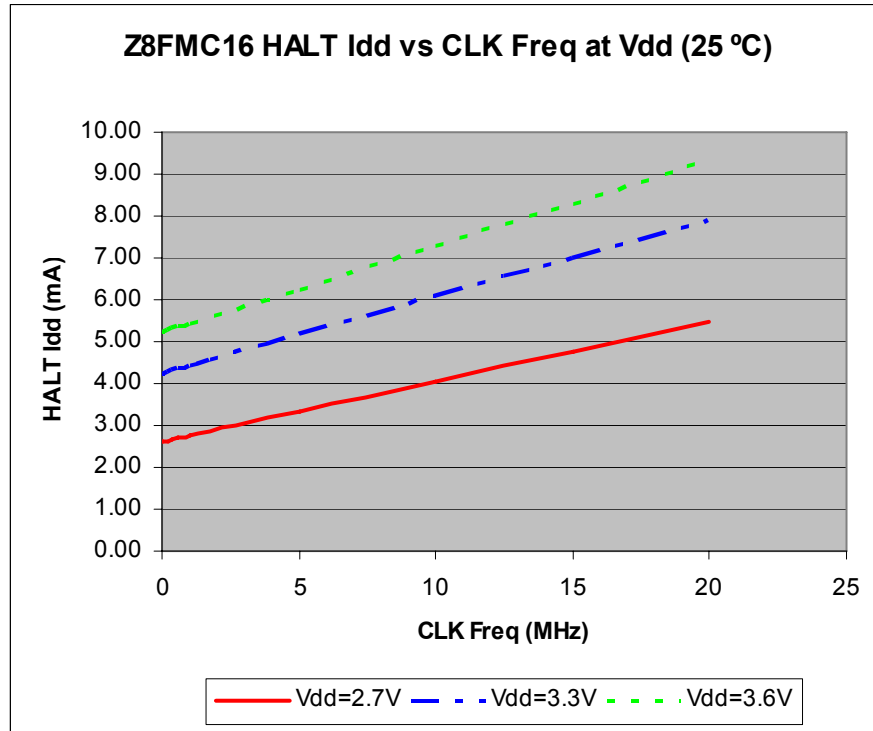

Figure 46. HALT Mode Current Consumption as a Function of Clock Frequency with V_{dd} as Parameter at 25 °C

Figure 47 displays the STOP mode supply current versus ambient temperature and VDD level with all the peripherals disabled. All GPIO pins are configured as outputs and driven High.

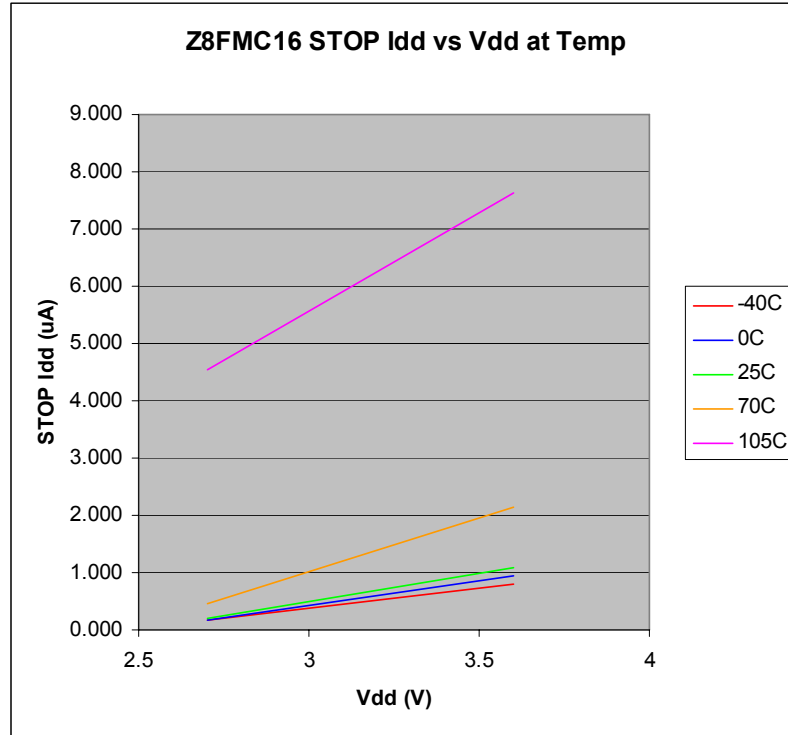

Figure 47. STOP Mode Current Consumption as a Function of Temperature with Vdd as Parameter—All Peripherals Disabled

AC Characteristics

The section provides information on the AC characteristics and timing. All AC timing information assumes a standard load of 50 pF on all outputs. Data in the typical column is from characterization at 3.3 V and 25 °C. These values are provided for design guidance only and are not tested in production.

Table 140. AC Characteristics

		$V_{DD} = 2.7\text{--}3.6\text{ V}$ $T_A = -40\text{ }^{\circ}\text{C to }105\text{ }^{\circ}\text{C}$				
Symbol	Parameter	Minimum	Maximum	Units	Conditions	
F_{SYSCLK}	System clock frequency	—	20.0	MHz		
F_{XTAL}	Crystal oscillator frequency	0.032768	20.0	MHz	System clock frequencies below the crystal oscillator minimum require an external clock driver.	
T_{XIN}	System clock period	50	—	ns	$T_{CLK} = 1 \div F_{SYSCLK}$.	
T_{XINH}	System clock high time	20	30	ns	$T_{CLK} = 50\text{ ns}$.	
T_{XINL}	System clock low time	20	30	ns	$T_{CLK} = 50\text{ ns}$.	

On-Chip Peripheral AC and DC Electrical Characteristics

Table 141 provides electrical characteristics and timing information for the POR and VBO circuits.

Table 141. POR and VBO Electrical Characteristics and Timing

		$T_A = -40\text{ }^{\circ}\text{C to }105\text{ }^{\circ}\text{C}$				
Symbol	Parameter	Minimum	Typical ¹	Maximum	Units	Conditions
V_{POR}	Power-On Reset voltage threshold	2.20	2.45	2.70	V	$V_{DD} = V_{POR}$.
V_{VBO}	Voltage Brownout reset voltage threshold	2.15	2.40	2.65	V	$V_{DD} = V_{VBO}$.
	$V_{POR} - V_{VBO}$		50	100	mV	
	Starting V_{DD} voltage to ensure valid Power-On Reset	—	V_{SS}	—	V	
T_{ANA}	Power-On Reset analog delay	—	50	—	ms	$V_{DD} > V_{POR}$; T_{POR} Digital Reset delay follows T_{ANA} .
T_{POR}	Power-On Reset digital delay	—	5.0	—	ms	50 WDT Oscillator cycles (10 kHz) + 16 System Clock cycles (20 MHz).

Table 141. POR and VBO Electrical Characteristics and Timing (Continued)

Symbol	Parameter	$T_A = -40\text{ }^\circ\text{C to }105\text{ }^\circ\text{C}$			Units	Conditions
		Minimum	Typical ¹	Maximum		
T_{VBO}	Voltage Brownout pulse rejection period	—	10	—	ms	$V_{DD} < V_{VBO}$ to generate a Reset.
T_{RAMP}	Time for V_{DD} to transition from V_{SS} to V_{POR} to ensure valid Reset	0.10	—	100	ms	
I_{CC}	Supply current		500		μA	$V_{DD} = 3.3\text{ V}$.

Note:

1. Data in the typical column is from characterization at 3.3 V and 25 °C. These values are provided for design guidance only and are not tested in production.

Table 142 provides electrical characteristics and timing information for the External RC Oscillator.

Table 142. External RC Oscillator Electrical Characteristics and Timing

Symbol	Parameter	$T_A = -40\text{ }^\circ\text{C to }105\text{ }^\circ\text{C}$			Units	Conditions
		Minimum	Typical ¹	Maximum		
V_{DD}	Operating voltage range	2.70 ¹	—	—	V	
R_{EXT}	External resistance from X_{IN} to V_{DD}	40	45	200	$\text{K}\Omega$	
C_{EXT}	External capacitance from X_{IN} to V_{SS}	0	20	1000	pF	
F_{OSC}	External RC oscillation frequency	—	—	4	MHz	

Note:

1. When using the external RC oscillator mode, the oscillator may stop oscillating if the power supply drops below 2.7 V, but before the power supply drops to the Voltage Brownout threshold. The oscillator resumes oscillation as soon as the supply voltage exceeds 2.7 V.

Table 143 provides electrical characteristics and timing information for the Internal Precision Oscillator.

Table 143. Internal Precision Oscillator Electrical Characteristics and Timing

Symbol	Parameter	$T_A = -40\text{ }^{\circ}\text{C to }105\text{ }^{\circ}\text{C}$			Units	Conditions
		Minimum	Typical	Maximum		
F_{Of}	Output frequency ¹	5.308 5.391	5.5296	5.75 5.668	MHz	4% limits Tighter limits are 2.5%; these are applicable at 3.3 V and 0 °C-70 °C and are based on characterization data. These are provided for design guidance ONLY. These limits ARE NOT tested in production.
I_{CC}	Supply current		1.6		mA	$V_{DD} = 3.3\text{ V.}$

Note:
1. The frequency is factory programmed.

Table 144 provides electrical characteristics and timing information for the Watchdog Timer.

Table 144. Watchdog Timer Electrical Characteristics and Timing

Symbol	Parameter	$V_{DD} = 2.7\text{--}3.6\text{ V}$ $T_A = -40\text{ }^{\circ}\text{C to }105\text{ }^{\circ}\text{C}$			Units	Conditions
		Minimum	Typical	Maximum		
F_{OSC}	Output frequency	5	10	20	kHz	$V_{DD} = 3.3\text{ V.}$
I_{CC}	Supply current		2		μA	$V_{DD} = 3.3\text{ V.}$

Table 145 provides electrical characteristics and timing information for the Reset and Stop Mode Recovery functions.

Table 145. Reset and Stop Mode Recovery Pin Timing

Symbol	Parameter	$T_A = -40\text{ }^\circ\text{C to }105\text{ }^\circ\text{C}$			Units	Conditions
		Minimum	Typical	Maximum		
T_{RESET}	RESET pin assertion to initiate a System Reset.	4	—	—	T_{CLK}	Not in STOP mode. T_{CLK} = System Clock period.
T_{SMR}	Stop Mode Recovery pin pulse rejection period	10	20	40	ns	RESET, DBG, and GPIO pins configured as SMR sources.

Table 146 provides electrical characteristics and timing information for the ADC and illustrates the input frequency response of the ADC.

Table 146. Analog-to-Digital Converter Electrical Characteristics and Timing

Symbol	Parameter	$T_A = -40\text{ }^\circ\text{C to }105\text{ }^\circ\text{C}$			Units	Conditions
		Minimum	Typical	Maximum		
	Resolution	10	—		bits	External $V_{\text{REF}} = 2.0\text{ V}$.
	Throughput conversion	13			CLKs	ADC clock cycles.
	ADCCLK frequency			20	MHz	
DNL	Differential nonlinearity for 8-bit use	-0.99		1.25	LSB	20 MHz sys clock with ADC clock divided by 4
INL	Integral nonlinearity for 8-bit use	-1.25		1.25	LSB	20 MHz sys clock with ADC clock divided by 4
DNL	Differential nonlinearity for 10-bit		2		LSB	20 MHz sys clock with ADC clock divided by 4
INL	Integral nonlinearity for 10-bit		2		LSB	20 MHz sys clock with ADC clock divided by 4
	Offset error	-30		30	mV	
	Gain error	-25		25	LSB	
V_{REF}	On-chip voltage reference	1.9	2	2.1	V	
	Analog input voltage range	0		V_{REF}	V	

Table 146. Analog-to-Digital Converter Electrical Characteristics and Timing (Continued)

		$T_A = -40\text{ }^\circ\text{C to }105\text{ }^\circ\text{C}$				
Symbol	Parameter	Minimum	Typical	Maximum	Units	Conditions
	Analog input current			500	nA	
	Reference input current		2.0		mA	Worst case code
Vref	External Vref voltage			AVDD -1.0 V	V	
	Analog input capacitance			15	pF	
AV _{DD}	Operation supply voltage	2.7		3.6	V	
	Operating current, AV _{DD}		9.0		mA	At 20 MHz ADC clock
	Power-down current		< 1		μA	

Table 147 provides electrical characteristics and timing information for the on-chip Comparator.

Table 147. Comparator Electrical Characteristics

		$= 2.7\text{--}3.6\text{ V}$ $T_A = -40\text{ }^\circ\text{C to }105\text{ }^\circ\text{C}$				
Symbol	Parameter	Minimum	Typical	Maximum	Units	Conditions
V _{COFF}	Input offset	—	5	15	mV	V _{DD} = 3.3 V; V _{IN} = V _{DD} ÷ 2.
T _{CPROP}	Propagation delay	—	200		ns	V _{comm} mode =1 V V _{diff} =100 mV
I _B	Input bias current			1	μA	
CMVR	Common-mode voltage range	-0.3		V _{DD} -1	V	
I _{CC}	Supply current		55		μA	V _{DD} = 3.6 V, 25 °C
T _{wup}	Wake up time from off state			5	μs	C _{INP} = 0.9 V C _{INN} = 1.0 V

Table 148 provides electrical characteristics and timing information for the on-chip Operational Amplifier.

Table 148. Operational Amplifier Electrical Characteristics

Symbol	Parameter	= 2.7–3.6 V $T_A = -40\text{ }^\circ\text{C to }105\text{ }^\circ\text{C}$			Units	Conditions
		Minimum	Typical	Maximum		
V_{OS}	Input offset		5	15	mV	$V_{DD} = 3.3\text{ V};$ $V_{CM} = V_{DD} \div 2.$
TC_{VOS}	Input offset Average Drift		1		$\mu\text{V}/\text{C}$	
I_B	Input bias current		TBD		μA	
I_{OS}	Input offset current		TBD		μA	
CMVR	Common-Mode Voltage Range	-0.3		$V_{DD} - 1$	V	
V_{OL}	Output Low			0.1	V	$I_{SINK} = 100\text{ }\mu\text{A}.$
V_{OH}	Output High	$V_{DD} - 1$			V	$I_{SOURCE} = 100\text{ }\mu\text{A}.$
CMRR	Common-Mode Rejection Ratio		70		dB	$0 < V_{CM} < 1.4\text{ V};$ $T_A = 25\text{ }^\circ\text{C}.$
PSRR	Power Supply Rejection Ratio		80		dB	$V_{DD} = 2.7\text{ V} - 3.6\text{ V};$ $T_A = 25\text{ }^\circ\text{C}.$
A_{VOL}	Voltage Gain		80		dB	
SR+	Slew Rate while rising		12		V/us	$R_{LOAD} = 33\text{ K};$ $C_{LOAD} = 50\text{ pF};$ $A_{VCL} = 1,$ $V_{IN} = 0.7\text{ V to }1.7\text{ V}.$
SR-	Slew Rate while falling		16		V/us	$R_{LOAD} = 33\text{ K};$ $C_{LOAD} = 50\text{ pF};$ $A_{VCL} = 1,$ $V_{IN} = 1.7\text{ V to }0.7\text{ V}.$
GBW	Gain-Bandwidth Product	5			MHz	
FM	Phase Margin		50		degree	
I_S	Supply Current			1	mA	$V_{DD} = 3.6\text{ V};$ $V_{OUT} = V_{DD} \div 2.$
T_{WUP}	Wake up time from off state			20	us	

General-Purpose Input/Output Port Input Data Sample Timing

Figure 48 displays the timing of the GPIO Port input sampling. Table 149 lists the GPIO port input timing.

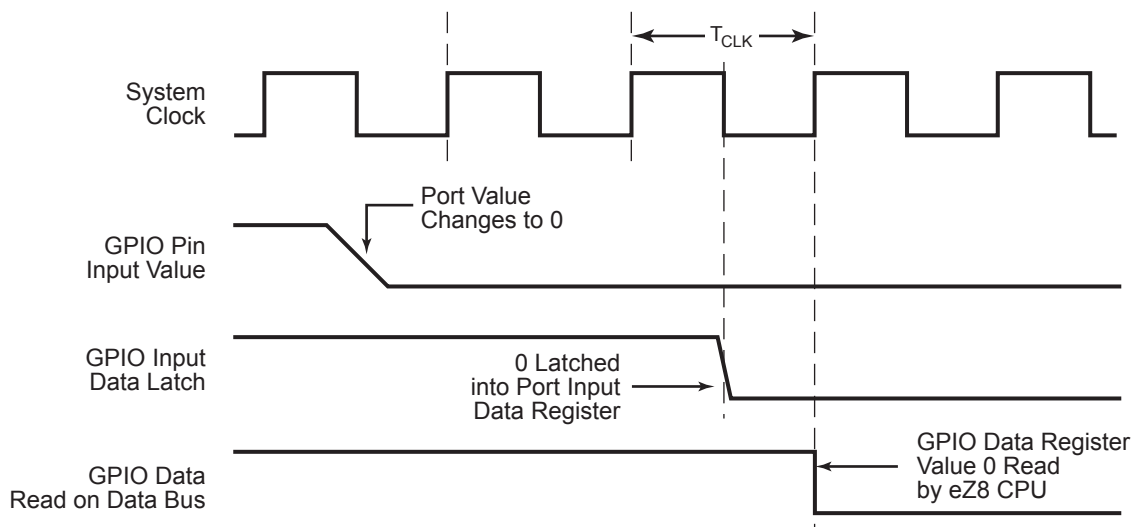

Figure 48. Port Input Sample Timing

Table 149 and Table 150 provide timing information for the GPIO Port inputs and outputs.

Table 149. GPIO Port Input Timing

Parameter	Abbreviation	Delay (ns)	
		Min	Max
T_{S_PORT}	Port input transition to X_{IN} fall setup time (Not pictured)	5	—
T_{H_PORT}	X_{IN} fall to port input transition hold time (not pictured).	5	—
T_{SMR}	GPIO port pin pulse width to ensure Stop Mode Recovery (for GPIO port pins enabled as SMR sources).	1 μ s	

General-Purpose Input/Output Port Output Timing

Figure 49 and Table 150 provide timing information for the GPIO port pins.

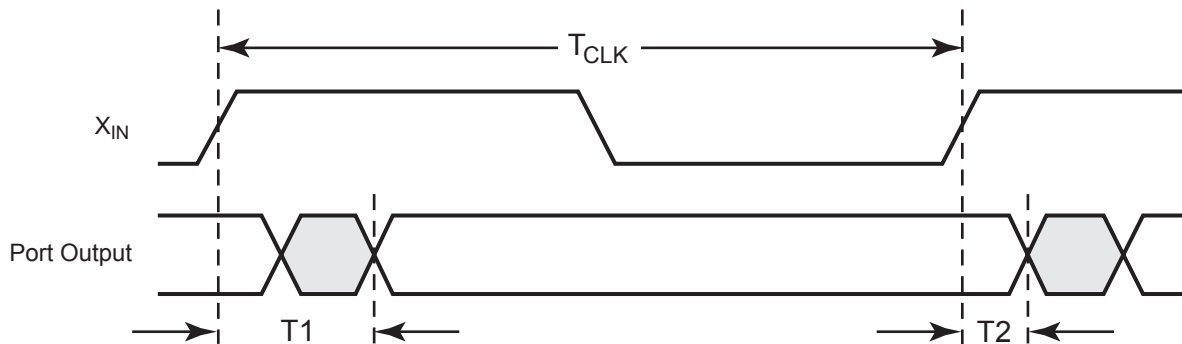

Figure 49. GPIO Port Output Timing

Table 150. GPIO Port Output Timing

Parameter	Abbreviation	Delay (ns)	
		Minimum	Maximum
T_1	X_{IN} Rise to Port Output Valid Delay	—	15
T_2	X_{IN} Rise to Port Output Hold Time	2	—

On-Chip Debugger Timing

Figure 50 and Table 151 provide timing information for the DBG pin. The DBG pin timing specifications assume a 4 μ s maximum rise and fall time.

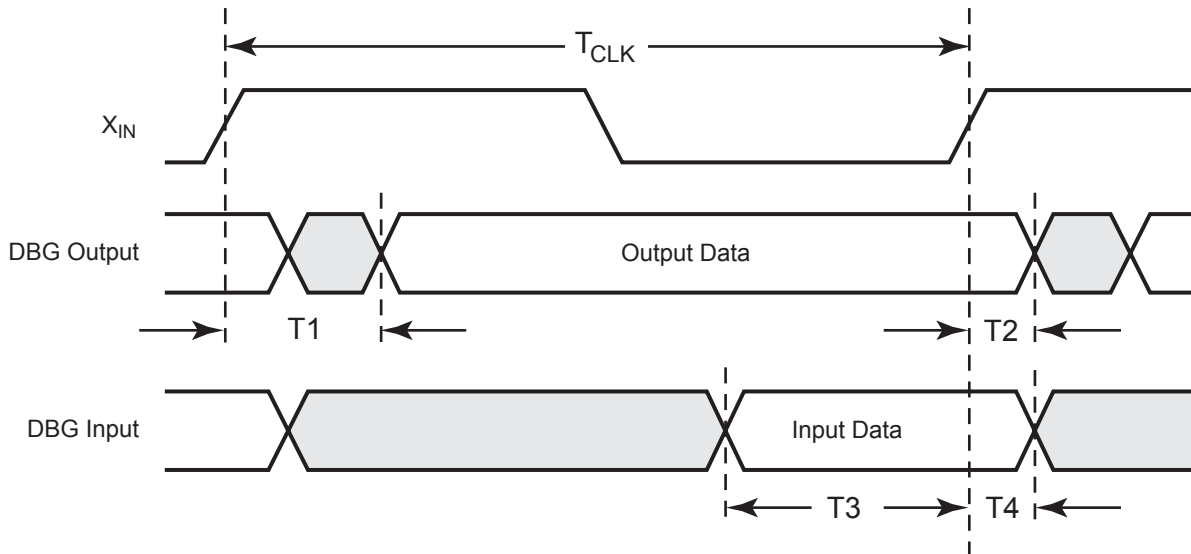

Figure 50. On-Chip Debugger Timing

Table 151. On-Chip Debugger Timing

Parameter	Abbreviation	Delay (ns)	
		Minimum	Maximum
T ₁	X _{IN} Rise to DBG Valid Delay	—	15
T ₂	X _{IN} Rise to DBG Output Hold Time	2	—
T ₃	DBG to X _{IN} Rise Input Setup Time	10	—
T ₄	DBG to X _{IN} Rise Input Hold Time	5	—
	DBG Frequency		System Clock ÷ 4

UART Timing

Figure 51 and Table 152 provide timing information for UART pins for the case where the Clear To Send input pin (CTS) is used for flow control. In this example, it is assumed that the Driver Enable polarity is configured to be Active Low and is represented here by \overline{DE} . The \overline{CTS} to \overline{DE} assertion delay (T_1) assumes the UART Transmit Data register is loaded with data prior to \overline{CTS} assertion.

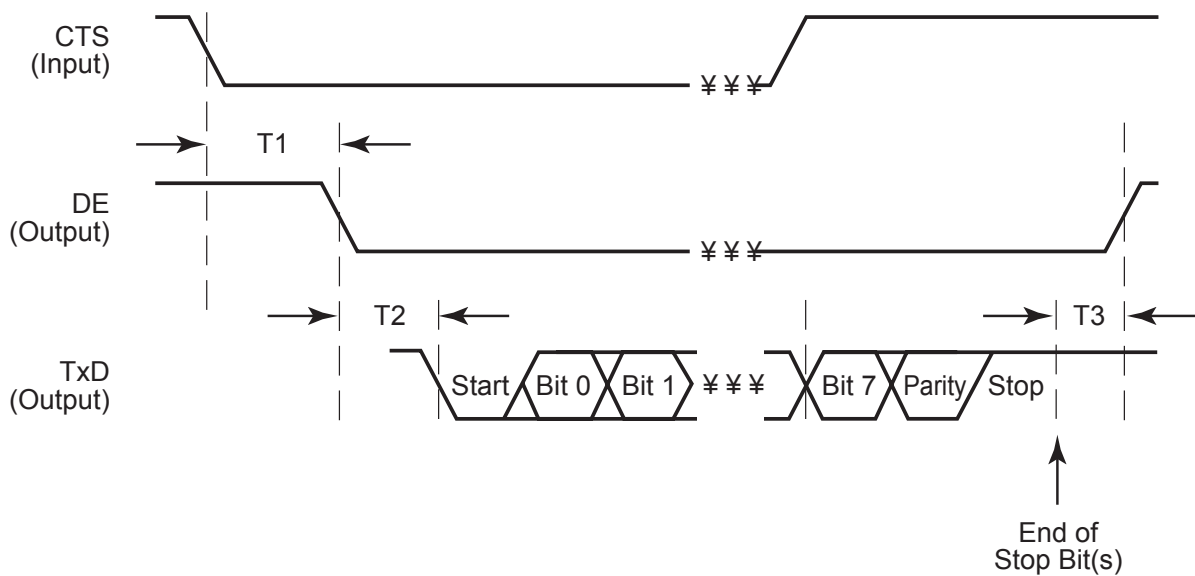

Figure 51. UART Timing with \overline{CTS}

Table 152. UART Timing with \overline{CTS}

Parameter	Abbreviation	Delay (ns)	
		Minimum	Maximum
T_1	\overline{CTS} fall to \overline{DE} assertion delay	$2 \times X_{IN}$ period	$2 \times X_{IN}$ period + 1 bit period
T_2	\overline{DE} assertion to TxD falling edge (start) delay	1 bit period	1 bit period + $1 \times X_{IN}$ period
T_3	End of stop bit (s) to \overline{DE} deassertion delay	$1 \times X_{IN}$ period	$2 \times X_{IN}$ period

Figure 52 and Table 153 provide timing information for UART pins for the case where the Clear To Send input signal ($\overline{\text{CTS}}$) is not used for flow control. In this example, it is assumed that the Driver Enable polarity is configured to be Active Low and is represented here by $\overline{\text{DE}}$. $\overline{\text{DE}}$ asserts after the UART Transmit Data register is written. $\overline{\text{DE}}$ remains asserted for multiple characters as long as the Transmit Data register is written with the next character before the current character has completed.

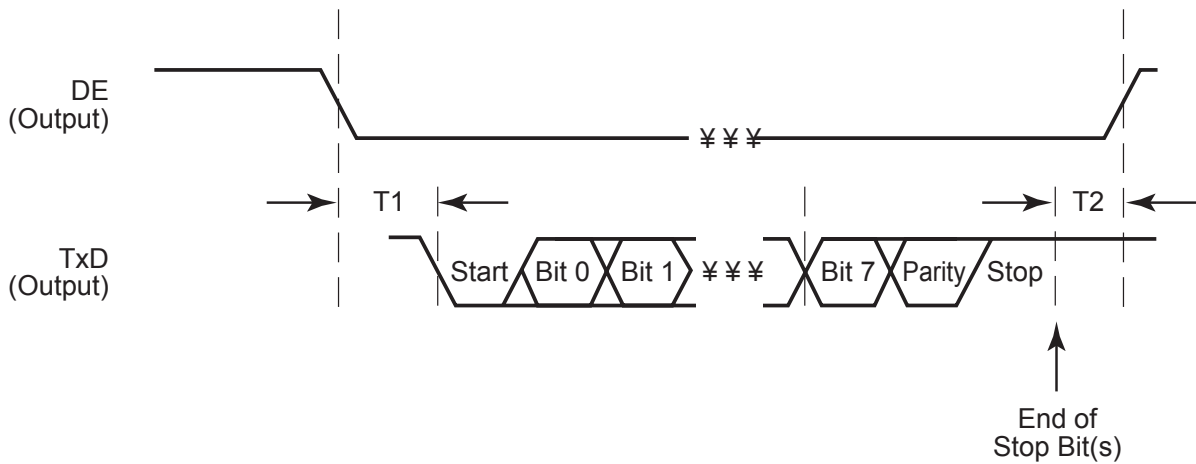

Figure 52. UART Timing without $\overline{\text{CTS}}$

Table 153. UART Timing without $\overline{\text{CTS}}$

Parameter	Abbreviation	Delay (ns)	
		Minimum	Maximum
T ₁	$\overline{\text{DE}}$ assertion to TxD falling edge (start) delay	1 bit period	1 bit period + 1 x X _{IN} period
T ₂	End of stop bit (s) to $\overline{\text{DE}}$ deassertion delay	1 x X _{IN} period	2 x X _{IN} period

eZ8 CPU Instruction Set

This chapter describes how to use the eZ8 CPU.

Assembly Language Programming Introduction

The eZ8 CPU assembly language provides a means for writing an application program without concern for actual memory addresses or machine instruction formats. A program written in assembly language is called a source program. Assembly language allows the use of symbolic addresses to identify memory locations. It also allows mnemonic codes (Opcodes and operands) to represent the instructions themselves. The Opcodes identify the instruction while the operands represent memory locations, registers, or immediate data values.

Each assembly language program consists of a series of symbolic commands called statements. Each statement can contain labels, operations, operands, and comments.

Labels can be assigned to a particular instruction step in a source program. The label identifies that step in the program as an entry point for use by other instructions.

The assembly language also includes assembler directives that supplement the machine instruction. The assembler directives, or pseudo-ops, are not translated into a machine instruction. Rather, the pseudo-ops are interpreted as directives that control or assist the assembly process. The source program is processed (assembled) by the assembler to obtain a machine language program called the object code. The object code is executed by the eZ8 CPU. An example segment of an assembly language program is detailed in the code below:

Assembly Language Source Program Example

```
JP START      ; Everything after the semicolon is a comment.
START:        ; A label called START. The first instruction (JP
              ; START) in this
              ; example causes program execution to jump to the
              ; point within the
              ; program where the START label occurs.
LD R4, R7     ; A Load (LD) instruction with two operands. The
              ; first operand,
              ; Working Register R4, is the destination. The
              ; second operand,
```

```

; Working Register R7, is the source. The contents
of R7 is
; written into R4.
LD 234H, #%01 ; Another Load (LD) instruction with two operands.
; The first operand, Extended Mode Register Address
234H,
; identifies the destination. The second operand,
Immediate Data
; value 01h, is the source. The value 01h is
written into the
; Register at address 234h.

```

Assembly Language Syntax

For proper instruction execution, eZ8 CPU assembly language syntax requires that the operands be written as ‘destination, source’. After assembly, the object code usually has the operands in the order ‘source, destination’, but ordering is Opcode-dependent. The following instruction examples illustrate the format of some basic assembly instructions and the resulting object code produced by the assembler. This binary format must be followed for manual program coding or for those who intend to implement their own assembler.

Example 1—If the contents of registers 43h and 08h are added and the result is stored in 43h, the assembly syntax and resulting object code is:

Assembly Language Code	ADD	43H,	08h	(ADD dst, src)
Object Code	04	08	43	(OPC src, dst)

Example 2—In general, when an instruction format requires an 8-bit register address, that address can specify any register location in the range 0–255 or, using Escaped Mode Addressing in working registers R0–R15. If the contents of Register 43h and Working Register R8 are added and the result is stored in 43h, the assembly syntax and resulting object code is:

Assembly Language Code	ADD	43H,	R8	(ADD dst, src)
Object Code	04	E8	43	(OPC src, dst)

- **Note:** *The size of the register file varies depending upon device type. The register file is 512 bytes for the Z8FMC16100 Series Flash MCU.*

eZ8 CPU Instruction Notation

In the eZ8 CPU Instruction Summary and Description sections, the operands, condition codes, status flags, and address modes are represented by a notational shorthand described in [Table 154](#).

Table 154. Notational Shorthand

Notation	Description	Operand	Range
b	Bit	b	b represents a value from 0 to 7 (000b to 111b).
cc	Condition Code	—	See Condition Codes overview in the <i>eZ8 CPU User Manual (UM0128)</i> .
DA	Direct Address	Addr	Addr represents a number in the range of 0000h to FFFFh.
ER	Extended Addressing Register	Reg	Reg. represents a number in the range of 000h to FFFh.
IM	Immediate Data	#Data	Data is a number between 00h to FFh.
Ir	Indirect Working Register	@Rn	n = 0–15.
IR	Indirect Register	@Reg	Reg. represents a number in the range of 00h to FFh.
Irr	Indirect Working Register Pair	@RRp	p = 0, 2, 4, 6, 8, 10, 12, or 14.
IRR	Indirect Register Pair	@Reg	Reg. represents an even number in the range 00h to FEh.
p	Polarity	p	Polarity is a single bit binary value of either 0b or 1b.
r	Working Register	Rn	n = 0–15.
R	Register	Reg	Reg. represents a number in the range of 00h to FFh.
RA	Relative Address	X	X represents an index in the range of +127 to –128, which is an offset relative to the address of the next instruction.
rr	Working Register Pair	RRp	p = 0, 2, 4, 6, 8, 10, 12, or 14.

Table 154. Notational Shorthand (Continued)

Notation	Description	Operand	Range
RR	Register Pair	Reg	Reg. represents an even number in the range of 00h to FEh.
Vector	Vector Address	Vector	Vector represents a number in the range of 00h to FFh.
X	Indexed	#Index	The register or register pair to be indexed is offset by the signed Index value (#Index) in a +127 to -128 range.

Table 155 contains additional symbols that are used throughout the Instruction Summary and Instruction Set Description sections.

Table 155. Additional Symbols

Symbol	Definition
dst	Destination Operand
src	Source Operand
@	Indirect Address Prefix
SP	Stack Pointer
PC	Program Counter
FLAGS	Flags Register
RP	Register Pointer
#	Immediate Operand Prefix
B	Binary Number Suffix
%	Hexadecimal Number Prefix
H	Hexadecimal Number Suffix

Assignment of a value is indicated by an arrow. For example,

$$\text{dst} \leftarrow \text{dst} + \text{src}$$

The above code indicates that source data is added to the destination data and the result is stored in the destination location.

Condition Codes

The C, Z, S, and V flags control the operation of the conditional jump (JP cc and JR cc) instructions. Sixteen frequently-useful functions of the flag settings are encoded in a 4-bit field called the condition code (cc), which forms Bits 7:4 of the conditional jump instructions. [Table 156](#) lists the condition codes. Some binary condition codes are created using more than one assembly code mnemonic. The result of the flag test operation decides whether the conditional jump is executed.

Table 156. Condition Codes

Binary	Hex	Assembly Mnemonic	Definition	Flag Test Operation
0000	0	F	Always False	—
0001	1	LT	Less Than	(S XOR V) = 1
0010	2	LE	Less Than or Equal	(Z or (S XOR V)) = 1
0011	3	ULE	Unsigned Less Than or Equal	(C OR Z) = 1
0100	4	OV	Overflow	V = 1
0101	5	MI	Minus	S = 1
0110	6	Z	Zero	Z = 1
0110	6	EQ	Equal	Z = 1
0111	7	C	Carry	C = 1
0111	7	ULT	Unsigned Less Than	C = 1
1000	8	T (or blank)	Always True	—
1001	9	GE	Greater Than or Equal	(S XOR V) = 0
1010	A	GT	Greater Than	(Z OR (S XOR V)) = 0
1011	B	UGT	Unsigned Greater Than	(C = 0 AND Z = 0) = 1
1100	C	NOV	No Overflow	V = 0
1101	D	PL	Plus	S = 0
1110	E	NZ	Non-Zero	Z = 0
1110	E	NE	Not Equal	Z = 0
1111	F	NC	No Carry	C = 0
1111	F	UGE	Unsigned Greater Than or Equal	C = 0

eZ8 CPU Instruction Classes

The eZ8 CPU instructions are divided functionally into the following groups:

- Arithmetic
- Bit Manipulation
- Block Transfer
- CPU Control
- Load
- Logical
- Program Control
- Rotate and Shift

Table 157 through Table 164 contain the instructions belonging to each group and the number of operands required for each instruction. Some instructions appear in more than one table as these instructions are considered as a subset of more than one category. Within these tables, the source operand is identified as *src*, the destination operand is *dst*, and a condition code is *cc*.

Table 157. Arithmetic Instructions

Mnemonic	Operands	Instruction
ADC	dst, src	Add with Carry
ADCX	dst, src	Add with Carry using extended addressing
ADD	dst, src	Add
ADDX	dst, src	Add using extended addressing
CP	dst, src	Compare
CPC	dst, src	Compare with Carry
CPCX	dst, src	Compare with Carry using extended addressing
CPX	dst, src	Compare using extended addressing
DA	dst	Decimal Adjust
DEC	dst	Decrement
DECW	dst	Decrement Word
INC	dst	Increment
INCW	dst	Increment Word

Table 157. Arithmetic Instructions (Continued)

Mnemonic	Operands	Instruction
MULT	dst	Multiply
SBC	dst, src	Subtract with Carry
SBCX	dst, src	Subtract with Carry using extended addressing
SUB	dst, src	Subtract
SUBX	dst, src	Subtract using extended addressing

Table 158. Bit Manipulation Instructions

Mnemonic	Operands	Instruction
BCLR	bit, dst	Bit Clear
BIT	p, bit, dst	Bit Set or Clear
BSET	bit, dst	Bit Set
BSWAP	dst	Bit Swap
CCF	—	Complement Carry Flag
RCF	—	Reset Carry Flag
SCF	—	Set Carry Flag
TCM	dst, src	Test Complement Under Mask
TCMX	dst, src	Test Complement Under Mask using extended addressing
TM	dst, src	Test Under Mask
TMX	dst, src	Test Under Mask using extended addressing

Table 159. Block Transfer Instructions

Mnemonic	Operands	Instruction
LDCI	dst, src	Load Constant to/from program memory and autoincrement addresses.
LDEI	dst, src	Load External Data to/from data memory and autoincrement addresses.

Table 160. CPU Control Instructions

Mnemonic	Operands	Instruction
CCF	—	Complement Carry Flag
DI	—	Disable Interrupts
EI	—	Enable Interrupts
HALT	—	HALT Mode
NOP	—	No Operation
RCF	—	Reset Carry Flag
SCF	—	Set Carry Flag
SRP	src	Set Register Pointer
STOP	—	STOP mode
WDT	—	Watchdog Timer Refresh

Table 161. Load Instructions

Mnemonic	Operands	Instruction
CLR	dst	Clear
LD	dst, src	Load
LDC	dst, src	Load Constant to/from program memory
LDCI	dst, src	Load Constant to/from program memory and autoincrement addresses
LDE	dst, src	Load External Data to/from data memory
LDEI	dst, src	Load External Data to/from data memory and autoincrement addresses
LDWX	dst, src	Load Word using extended addressing
LDX	dst, src	Load using extended addressing
LEA	dst, X(src)	Load Effective Address
POP	dst	Pop
POPX	dst	Pop using extended addressing
PUSH	src	Push
PUSHX	src	Push using extended addressing

Table 162. Logical Instructions

Mnemonic	Operands	Instruction
AND	dst, src	Logical AND
ANDX	dst, src	Logical AND using extended addressing
COM	dst	Complement
OR	dst, src	Logical OR
ORX	dst, src	Logical OR using extended addressing
XOR	dst, src	Logical Exclusive OR
XORX	dst, src	Logical Exclusive OR using extended addressing

Table 163. Program Control Instructions

Mnemonic	Operands	Instruction
ATM	—	Atomic
BRK	—	On-Chip Debugger Break
BTJ	p, bit, src, DA	Bit Test and Jump
BTJNZ	bit, src, DA	Bit Test and Jump if Non-Zero
BTJZ	bit, src, DA	Bit Test and Jump if Zero
CALL	dst	Call Procedure
DJNZ	dst, src, RA	Decrement and Jump Non-Zero
IRET	—	Interrupt Return
JP	dst	Jump
JP cc	dst	Jump Conditional
JR	DA	Jump Relative
JR cc	DA	Jump Relative Conditional
RET	—	Return
TRAP	vector	Software Trap

Table 164. Rotate and Shift Instructions

Mnemonic	Operands	Instruction
BSWAP	dst	Bit Swap
RL	dst	Rotate Left
RLC	dst	Rotate Left through Carry
RR	dst	Rotate Right
RRC	dst	Rotate Right through Carry
SRA	dst	Shift Right Arithmetic
SRL	dst	Shift Right Logical
SWAP	dst	Swap Nibbles

eZ8 CPU Instruction Summary

Table 165 lists the eZ8 CPU instructions. This table identifies the addressing modes employed by the instruction, the effect upon the Flags register, the number of CPU clock cycles required for the instruction fetch, and the number of CPU clock cycles required for the instruction execution.

Table 165. eZ8 CPU Instruction Summary

Assembly Mnemonic	Symbolic Operation	Address Mode		Opcode (s) (Hex)	Flags						Fetch Cycles	Instr. Cycles
		dst	src		C	Z	S	V	D	H		
ADC dst, src	$dst \leftarrow dst + src + C$	r	r	12	*	*	*	*	0	*	2	3
		r	lr	13							2	4
		R	R	14							3	3
		R	IR	15							3	4
		R	IM	16							3	3
		IR	IM	17							3	4
ADCX dst, src	$dst \leftarrow dst + src + C$	ER	ER	18	*	*	*	*	0	*	4	3
		ER	IM	19							4	3

Table 165. eZ8 CPU Instruction Summary (Continued)

Assembly Mnemonic	Symbolic Operation	Address Mode		Opcode (s) (Hex)	Flags						Fetch Cycles	Instr. Cycles
		dst	src		C	Z	S	V	D	H		
ADD dst, src	dst ← dst + src	r	r	02	*	*	*	*	0	*	2	3
		r	lr	03							2	4
		R	R	04							3	3
		R	IR	05							3	4
		R	IM	06							3	3
		IR	IM	07							3	4
ADDX dst, src	dst ← dst + src	ER	ER	08	*	*	*	*	0	*	4	3
		ER	IM	09							4	3
AND dst, src	dst ← dst + src	r	r	52	—	*	*	0	—	—	2	3
		r	lr	53							2	4
		R	R	54							3	3
		R	IR	55							3	4
		R	IM	56							3	3
		IR	IM	57							3	4
ANDX dst, src	dst ← dst AND src	ER	ER	58	—	*	*	0	—	—	4	3
		ER	IM	59							4	3
ATM	Atomic execution			2F	—	—	—	—	—	—	1	1
BCLR bit, dst	dst[bit] ← 0	r		E2	—	*	*	0	—	—	2	2
BIT p, bit, dst	dst[bit] ← p	r		E2	—	*	*	0	—	—	2	2
BRK	Debugger Break			00	—	—	—	—	—	—	1	1
BSET bit, dst	dst[bit] ← 1	r		E2	—	*	*	0	—	—	2	2
BSWAP dst	dst[7:0] ← dst[0:7]	R		D5	X	*	*	0	-	-	2	2
BTJ p, bit, src, dst	if src[bit] = p PC ← PC + X	r		F6	—	—	—	—	—	—	3	3
		lr		F7							3	4
BTJNZ bit, src, dst	if src[bit] = 1 PC ← PC + X	r		F6	—	—	—	—	—	—	3	3
		lr		F7							3	4
BTJZ bit, src, dst	if src[bit] = 0 PC ← PC + X	r		F6	—	—	—	—	—	—	3	3
		lr		F7							3	4

Table 165. eZ8 CPU Instruction Summary (Continued)

Assembly Mnemonic	Symbolic Operation	Address Mode		Opcode (s) (Hex)	Flags						Fetch Cycles	Instr. Cycles
		dst	src		C	Z	S	V	D	H		
CALL dst	SP ← SP – 2	IRR		D4	—	—	—	—	—	—	2	6
	@SP ← PC PC ← dst	DA		D6	—	—	—	—	—	—	3	3
CCF	C ← ~C			EF	*	—	—	—	—	—	1	2
CLR dst	dst ← 00h	R		B0	—	—	—	—	—	—	2	2
		IR		B1	—	—	—	—	—	—	2	3
COM dst	dst ← ~dst	R		60	—	*	*	0	—	—	2	2
		IR		61	—	—	—	—	—	—	2	3
CP dst, src	dst – src	r	r	A2	*	*	*	*	—	—	2	3
		r	lr	A3	—	—	—	—	—	—	2	4
		R	R	A4	—	—	—	—	—	—	3	3
		R	IR	A5	—	—	—	—	—	—	3	4
		R	IM	A6	—	—	—	—	—	—	3	3
		IR	IM	A7	—	—	—	—	—	—	3	4
CPC dst, src	dst – src – C	r	r	1F A2	*	*	*	*	—	—	3	3
		r	lr	1F A3	—	—	—	—	—	—	3	4
		R	R	1F A4	—	—	—	—	—	—	4	3
		R	IR	1F A5	—	—	—	—	—	—	4	4
		R	IM	1F A6	—	—	—	—	—	—	4	3
		IR	IM	1F A7	—	—	—	—	—	—	4	4
CPCX dst, src	dst – src – C	ER	ER	1F A8	*	*	*	*	—	—	5	3
		ER	IM	1F A9	—	—	—	—	—	—	5	3
CPX dst, src	dst – src	ER	ER	A8	*	*	*	*	—	—	4	3
		ER	IM	A9	—	—	—	—	—	—	4	3
DA dst	dst ← DA(dst)	R		40	*	*	*	X	—	—	2	2
		IR		41	—	—	—	—	—	—	2	3
DEC dst	dst ← dst – 1	R		30	—	*	*	*	v	—	2	2
		IR		31	—	—	—	—	—	—	2	3

Table 165. eZ8 CPU Instruction Summary (Continued)

Assembly Mnemonic	Symbolic Operation	Address Mode		Opcode (s) (Hex)	Flags						Fetch Cycles	Instr. Cycles
		dst	src		C	Z	S	V	D	H		
DECW dst	dst ← dst – 1	RR		80	—	*	*	*	—	—	2	5
		IRR		81							2	6
DI	IRQE ← 0			8F	—	—	—	—	—	—	1	2
DJNZ dst, RA	dst ← dst – 1 if dst ≠ 0 PC ← PC + X	r		0A–FA	—	—	—	—	—	—	2	3
EI	IRQE ← 1			9F	—	—	—	—	—	—	1	2
HALT	HALT Mode			7F	—	—	—	—	—	—	1	2
INC dst	dst ← dst + 1	R		20	—	*	*	*	—	—	2	2
		IR		21							2	3
		r		0E–FE							1	2
INCW dst	dst ← dst + 1	RR		A0	—	*	*	*	—	—	2	5
		IRR		A1							2	6
IRET	FLAGS ← @SP SP ← SP + 1 PC ← @SP SP ← SP + 2 IRQE ← 1			BF	*	*	*	*	*	*	1	5
JP dst	PC ← dst	DA		8D	—	—	—	—	—	—	3	2
		IRR		C4							2	3
JP cc, dst	if cc is true PC ← dst	DA		0D–FD	—	—	—	—	—	—	3	2
JR dst	PC ← PC + X	DA		8B	—	—	—	—	—	—	2	2
JR cc, dst	if cc is true PC ← PC + X	DA		0B–FB	—	—	—	—	—	—	2	2

Table 165. eZ8 CPU Instruction Summary (Continued)

Assembly Mnemonic	Symbolic Operation	Address Mode		Opcode (s) (Hex)	Flags						Fetch Cycles	Instr. Cycles
		dst	src		C	Z	S	V	D	H		
LD dst, rc	dst ← src	r	IM	0C–FC	—	—	—	—	—	—	2	2
		r	X(r)	C7							3	3
		X(r)	r	D7							3	4
		r	lr	E3							2	3
		R	R	E4							3	2
		R	IR	E5							3	4
		R	IM	E6							3	2
		IR	IM	E7							3	3
		lr	r	F3							2	3
		IR	R	F5							3	3
LDC dst, src	dst ← src	r	lrr	C2	—	—	—	—	—	—	2	5
		lr	lrr	C5							2	9
		lrr	r	D2							2	5
LDCI dst, src	dst ← src r ← r + 1 rr ← rr + 1	lr	lrr	C3	—	—	—	—	—	—	2	9
		lrr	lr	D3							2	9
LDE dst, src	dst ← src	r	lrr	82	—	—	—	—	—	—	2	5
		lrr	r	92							2	5
LDEI dst, src	dst ← src r ← r + 1 rr ← rr + 1	lr	lrr	83	—	—	—	—	—	—	2	9
		lrr	lr	93							2	9
LDWX dst, src	dst ← src	ER	ER	1F E8	—	—	—	—	—	—	5	4

Table 165. eZ8 CPU Instruction Summary (Continued)

Assembly Mnemonic	Symbolic Operation	Address Mode		Opcode (s) (Hex)	Flags						Fetch Cycles	Instr. Cycles
		dst	src		C	Z	S	V	D	H		
LDX dst, src	dst ← src	r	ER	84	—	—	—	—	—	—	3	2
		lr	ER	85							3	3
		R	IRR	86							3	4
		IR	IRR	87							3	5
		r	X(rr)	88							3	4
		X(rr)	r	89							3	4
		ER	r	94							3	2
		ER	lr	95							3	3
		IRR	R	96							3	4
		IRR	IR	97							3	5
		ER	ER	E8							4	2
		ER	IM	E9							4	2
LEA dst, X(src)	dst ← src + X	r	X(r)	98	—	—	—	—	—	—	3	3
		rr	X(rr)	99							3	5
MULT dst	dst[15:0] ← dst[15:8] * dst[7:0]	RR		F4	—	—	—	—	—	—	2	8
NOP	No operation			0F	—	—	—	—	—	—	1	2
OR dst, src	dst ← dst OR src	r	r	42	—	*	*	0	—	—	2	3
		r	lr	43							2	4
		R	R	44							3	3
		R	IR	45							3	4
		R	IM	46							3	3
		IR	IM	47							3	4
ORX dst, src	dst ← dst OR src	ER	ER	48	—	*	*	0	—	—	4	3
		ER	IM	49							4	3
POP dst	dst ← @SP SP ← SP + 1	R		50	—	—	—	—	—	—	2	2
		IR		51							2	3

Table 165. eZ8 CPU Instruction Summary (Continued)

Assembly Mnemonic	Symbolic Operation	Address Mode		Opcode (s) (Hex)	Flags						Fetch Cycles	Instr. Cycles
		dst	src		C	Z	S	V	D	H		
POPX dst	dst ← @SP SP ← SP + 1	ER		D8	—	—	—	—	—	—	3	2
PUSH src	SP ← SP – 1 @SP ← src	R		70	—	—	—	—	—	—	2	2
		IR		71							2	3
		IM		1F 70							3	2
PUSHX src	SP ← SP – 1 @SP ← src	ER		C8	—	—	—	—	—	—	3	2
RCF	C ← 0			CF	0	—	—	—	—	—	1	2
RET	PC ← @SP SP ← SP + 2			AF	—	—	—	—	—	—	1	4
RL dst		R		90	*	*	*	*	—	—	2	2
		IR		91							2	3
RLC dst		R		10	*	*	*	*	—	—	2	2
		IR		11							2	3
RR dst		R		E0	*	*	*	*	—	—	2	2
		IR		E1							2	3
RRC dst		R		C0	*	*	*	*	—	—	2	2
		IR		C1							2	3
SBC dst, src	dst ← dst – src – C	r	r	32	*	*	*	*	1	*	2	3
		r	lr	33							2	4
		R	R	34							3	3
		R	IR	35							3	4
		R	IM	36							3	3
		IR	IM	37							3	4
SBCX dst, src	dst ← dst – src – C	ER	ER	38	*	*	*	*	1	*	4	3
		ER	IM	39							4	3
SCF	C ← 1			DF	1	—	—	—	—	—	1	2
SRA dst		R		D0	*	*	*	0	—	—	2	2
		IR		D1							2	3

Table 165. eZ8 CPU Instruction Summary (Continued)

Assembly Mnemonic	Symbolic Operation	Address Mode		Opcode (s) (Hex)	Flags						Fetch Cycles	Instr. Cycles
		dst	src		C	Z	S	V	D	H		
SRL dst		R		1F C0	*	*	0	*	—	—	3	2
		IR		1F C1								3
SRP src	RP ← src		IM	01	—	—	—	—	—	—	2	2
STOP	STOP mode			6F	—	—	—	—	—	—	1	2
SUB dst, src	dst ← dst – src	r	r	22	*	*	*	*	1	*	2	3
		r	lr	23							2	4
		R	R	24							3	3
		R	IR	25							3	4
		R	IM	26							3	3
		IR	IM	27							3	4
SUBX dst, src	dst ← dst – src	ER	ER	28	*	*	*	*	1	*	4	3
		ER	IM	29							4	3
SWAP dst	dst[7:4] ↔ dst[3:0]	R		F0	X	*	*	X	—	—	2	2
		IR		F1							2	3
TCM dst, src	(NOT dst) AND src	r	r	62	—	*	*	0	—	—	2	3
		r	lr	63							2	4
		R	R	64							3	3
		R	IR	65							3	4
		R	IM	66							3	3
		IR	IM	67							3	4
TCMX dst, src	(NOT dst) AND src	ER	ER	68	—	*	*	0	—	—	4	3
		ER	IM	69							4	3
TM dst, src	dst AND src	r	r	72	—	*	*	0	—	—	2	3
		r	lr	73							2	4
		R	R	74							3	3
		R	IR	75							3	4
		R	IM	76							3	3
		IR	IM	77							3	4

Table 165. eZ8 CPU Instruction Summary (Continued)

Assembly Mnemonic	Symbolic Operation	Address Mode		Opcode (s) (Hex)	Flags						Fetch Cycles	Instr. Cycles
		dst	src		C	Z	S	V	D	H		
TMX dst, src	dst AND src	ER	ER	78	—	*	*	0	—	—	4	3
		ER	IM	79							4	3
TRAP Vector	SP ← SP – 2 @SP ← PC SP ← SP – 1 @SP ← FLAGS PC ← @Vector		Vect or	F2	—	—	—	—	—	—	2	6
WDT				5F	—	—	—	—	—	—	1	2
XOR dst, src	dst ← dst XOR src	r	r	B2	—	*	*	0	—	—	2	3
		r	lr	B3							2	4
		R	R	B4							3	3
		R	IR	B5							3	4
		R	IM	B6							3	3
		IR	IM	B7							3	4
XORX dst, src	dst ← dst XOR src	ER	ER	B8	—	*	*	0	—	—	4	3
		ER	IM	B9							4	3

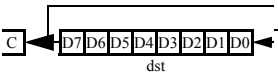
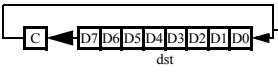
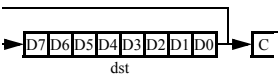
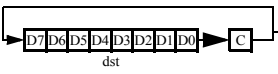
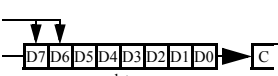
Note: Flags Notation:

- * = Value is a function of the result of the operation.
- = unaffected.
- X = undefined.
- 0 = reset to 0.
- 1 = set to 1.

Flags Register

The Flags register contains the status information regarding the most recent arithmetic, logical, bit manipulation, or rotate and shift operation. The Flags register contains six bits of status information that are set or cleared by CPU operations. Four of the bits (C, V, Z, and S) are tested for use with conditional jump instructions. Two flags (H and D) cannot be tested and are used for Binary-Coded Decimal (BCD) arithmetic.

The two remaining bits, User Flags (F1 and F2), are available as general-purpose status bits. User Flags are unaffected by arithmetic operations and must be set or cleared by instructions. The User Flags cannot be used with conditional Jumps. They are undefined at

initial power-up and are unaffected by Reset. Figure 53 displays the flags and their bit positions in the Flags register.

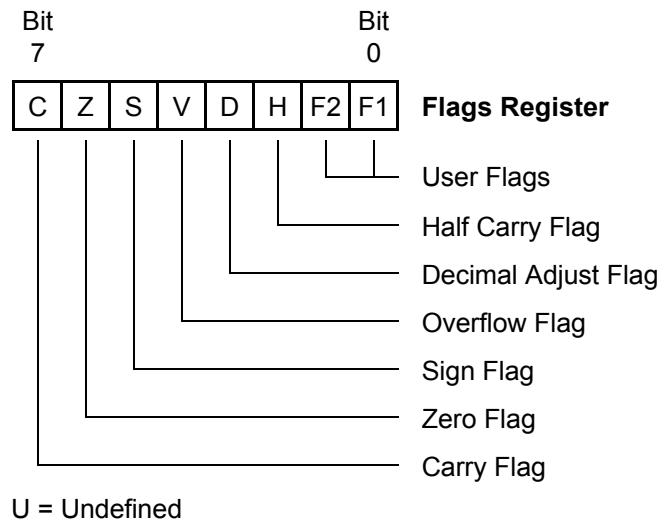

Figure 53. Flags Register

Interrupts, the software trap (TRAP) instruction, and illegal instruction traps write the value of the Flags register to the stack. Executing an Interrupt Return (IRET) instruction restores the value saved on the stack into the Flags register.



Opcode Maps

Figure 54 and Table 166 provide descriptions of the Opcode map data and the abbreviations. Figure 55 and Figure 56 provide information about each of the eZ8 CPU instructions.

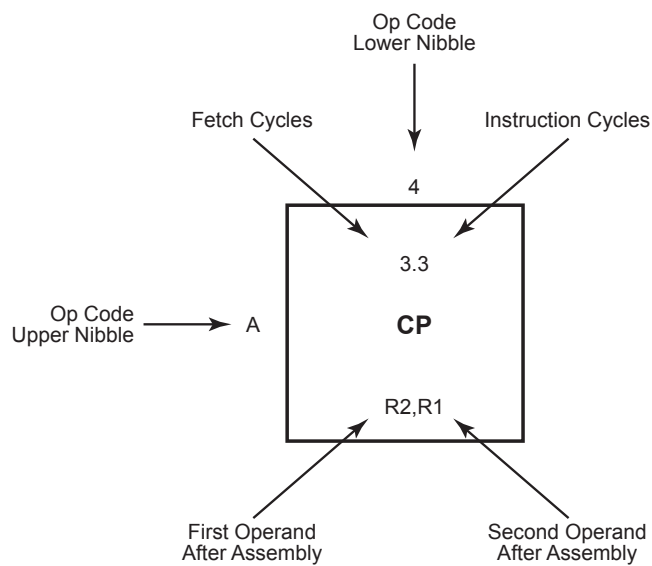

Figure 54. Opcode Map Cell Description

Table 166. Opcode Map Abbreviations

Abbreviation	Description	Abbreviation	Description
b	Bit position	IRR	Indirect Register Pair
cc	Condition code	p	Polarity (0 or 1)
X	8-bit signed index or displacement	r	4-bit Working Register
DA	Destination address	R	8-bit Register
ER	Extended Addressing Register	r1, R1, Ir1, Irr1, IR1, rr1, RR1, IRR1, ER1	Destination address
IM	Immediate data value	r2, R2, Ir2, Irr2, IR2, rr2, RR2, IRR2, ER2	Source address
Ir	Indirect Working Register	RA	Relative

Table 166. Opcode Map Abbreviations (Continued)

Abbreviation	Description	Abbreviation	Description
IR	Indirect Register	rr	Working Register Pair
Irr	Indirect Working Register Pair	RR	Register Pair

		Lower Nibble (Hex)																
		0	1	2	3	4	5	6	7	8	9	A	B	C	D	E	F	
Upper Nibble (Hex)	0	1.1 BRK	2.2 SRP IM	2.3 ADD r1,r2	2.4 ADD r1,lr2	3.3 ADD R2,R1	3.4 ADD IR2,R1	3.3 ADD R1,IM	3.4 ADD IR1,IM	4.3 ADDX ER2,ER1	4.3 ADDX IM,ER1	2.3 DJNZ r1,X	2.2 JR cc,X	2.2 LD r1,IM	3.2 JP cc,DA	1.2 INC r1	1.2 NOP	
	1	2.2 RLC R1	2.3 RLC IR1	2.3 ADC r1,r2	2.4 ADC r1,lr2	3.3 ADC R2,R1	3.4 ADC IR2,R1	3.3 ADC R1,IM	3.4 ADC IR1,IM	4.3 ADCX ER2,ER1	4.3 ADCX IM,ER1							See 2nd Op Code Map
	2	2.2 INC R1	2.3 INC IR1	2.3 SUB r1,r2	2.4 SUB r1,lr2	3.3 SUB R2,R1	3.4 SUB IR2,R1	3.3 SUB R1,IM	3.4 SUB IR1,IM	4.3 SUBX ER2,ER1	4.3 SUBX IM,ER1							1.1 ATM
	3	2.2 DEC R1	2.3 DEC IR1	2.3 SBC r1,r2	2.4 SBC r1,lr2	3.3 SBC R2,R1	3.4 SBC IR2,R1	3.3 SBC R1,IM	3.4 SBC IR1,IM	4.3 SBCX ER2,ER1	4.3 SBCX IM,ER1							
	4	2.2 DA R1	2.3 DA IR1	2.3 OR r1,r2	2.4 OR r1,lr2	3.3 OR R2,R1	3.4 OR IR2,R1	3.3 OR R1,IM	3.4 OR IR1,IM	4.3 ORX ER2,ER1	4.3 ORX IM,ER1							
	5	2.2 POP R1	2.3 POP IR1	2.3 AND r1,r2	2.4 AND r1,lr2	3.3 AND R2,R1	3.4 AND IR2,R1	3.3 AND R1,IM	3.4 AND IR1,IM	4.3 ANDX ER2,ER1	4.3 ANDX IM,ER1							1.2 WDT
	6	2.2 COM R1	2.3 COM IR1	2.3 TCM r1,r2	2.4 TCM r1,lr2	3.3 TCM R2,R1	3.4 TCM IR2,R1	3.3 TCM R1,IM	3.4 TCM IR1,IM	4.3 TCMX ER2,ER1	4.3 TCMX IM,ER1							1.2 STOP
	7	2.2 PUSH R2	2.3 PUSH IR2	2.3 TM r1,r2	2.4 TM r1,lr2	3.3 TM R2,R1	3.4 TM IR2,R1	3.3 TM R1,IM	3.4 TM IR1,IM	4.3 TMX ER2,ER1	4.3 TMX IM,ER1							1.2 HALT
	8	2.5 DECW RR1	2.6 DECW IRR1	2.5 LDE r1,lr2	2.8 LDEI lr1,lr2	3.2 LDX r1,ER2	3.3 LDX lr1,ER2	3.4 LDX IRR2,R1	3.5 LDX IRR2,IR1	3.4 LDX³ r1,rr2,X	3.4 LDX³ rr1,r2,X							1.2 DI
	9	2.2 RL R1	2.3 RL IR1	2.5 LDE r2,lr1	2.8 LDEI lr2,lr1	3.2 LDX r2,ER1	3.3 LDX lr2,ER1	3.4 LDX R2,IRR1	3.5 LDX IR2,IRR1	3.3 LEA r1,r2,X	3.5 LEA³ rr1,rr2,X							1.2 EI
	A	2.5 INCW RR1	2.6 INCW IRR1	2.3 CP r1,r2	2.4 CP r1,lr2	3.3 CP R2,R1	3.4 CP IR2,R1	3.3 CP R1,IM	3.4 CP IR1,IM	4.3 CPX ER2,ER1	4.3 CPX IM,ER1							1.4 RET
	B	2.2 CLR R1	2.3 CLR IR1	2.3 XOR r1,r2	2.4 XOR r1,lr2	3.3 XOR R2,R1	3.4 XOR IR2,R1	3.3 XOR R1,IM	3.4 XOR IR1,IM	4.3 XORX ER2,ER1	4.3 XORX IM,ER1							1.5 IRET
	C	2.2 RRC R1	2.3 RRC IR1	2.5 LDC r1,lr2	2.8 LDCI lr1,lr2	2.3 JP² IRR1	2.8 LDC lr1,lr2		3.4 LD r1,r2,X	3.3 PUSHX³ ER2								1.2 RCF
	D	2.2 SRA R1	2.3 SRA IR1	2.5 LDC r2,lr1	2.8 LDCI lr2,lr1	2.6 CALL² IRR1	2.2 BSWAP R1	3.3 CALL DA	3.4 LD r2,r1,X	3.3 POPX³ ER1								1.2 SCF
	E	2.2 RR R1	2.3 RR IR1	2.2 BIT p,b,r1	2.3 LD r1,lr2	3.2 LD R2,R1	3.3 LD IR2,R1	3.3 LD R1,IM	3.4 LD IR1,IM	4.2 LDX ER2,ER1	4.2 LDX IM,ER1							1.2 CCF
	F	2.2 SWAP R1	2.3 SWAP IR1	2.6 TRAP Vector	2.3 LD lr1,r2	2.9 MULT RR1	3.3 LD R2,IR1	3.3 BTJ p,b,r1,X	3.4 BTJ p,b,lr1,X									

Figure 55. First Opcode Map

		Lower Nibble (Hex)															
		0	1	2	3	4	5	6	7	8	9	A	B	C	D	E	F
Upper Nibble (Hex)	0																
	1																
	2																
	3																
	4																
	5																
	6																
	7																
	8																
	9																
	A			3.3 CPC r1,r2	3.4 CPC r1,lr2	4.3 CPC R2,R1	4.4 CPC IR2,R1	4.3 CPC R1,IM	4.4 CPC IR1,IM	5.3 CPCX ER2,ER1	5.3 CPCX IM,ER1						
	B																
	C		3.2 SRL R1	3.3 SRL IR1													
	D																
	E										4.2 LDWX ER2,ER1						
	F																

Figure 56. Second Opcode Map after 1Fh

Packaging

Figure 57 displays the 32-pin quad flat no lead (QFN) package available for the Z8FMC16100 Series Flash MCU.

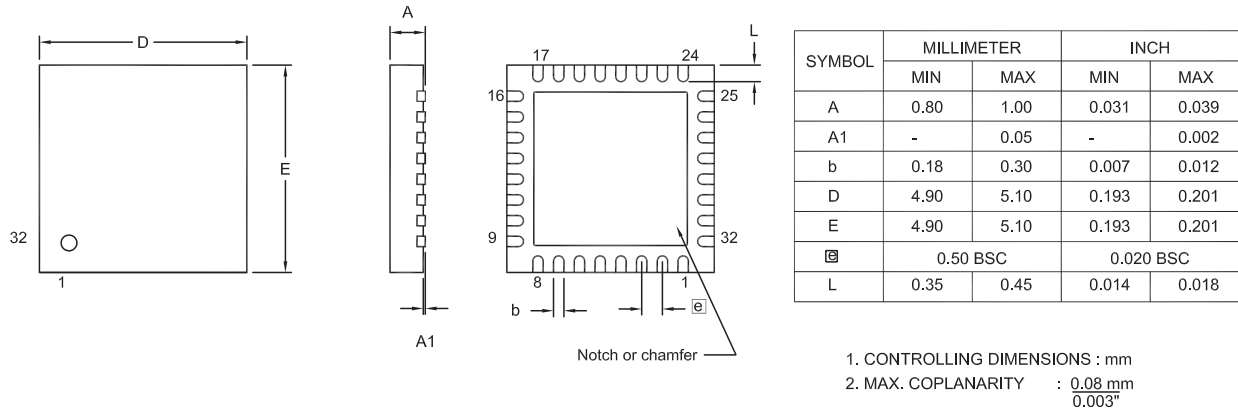

Figure 57. 32-Pin Quad Flat No Lead Package

Figure 58 displays the 32-pin low quad flat package (LQFP) available for the Z8FMC16100 Series Flash MCU.

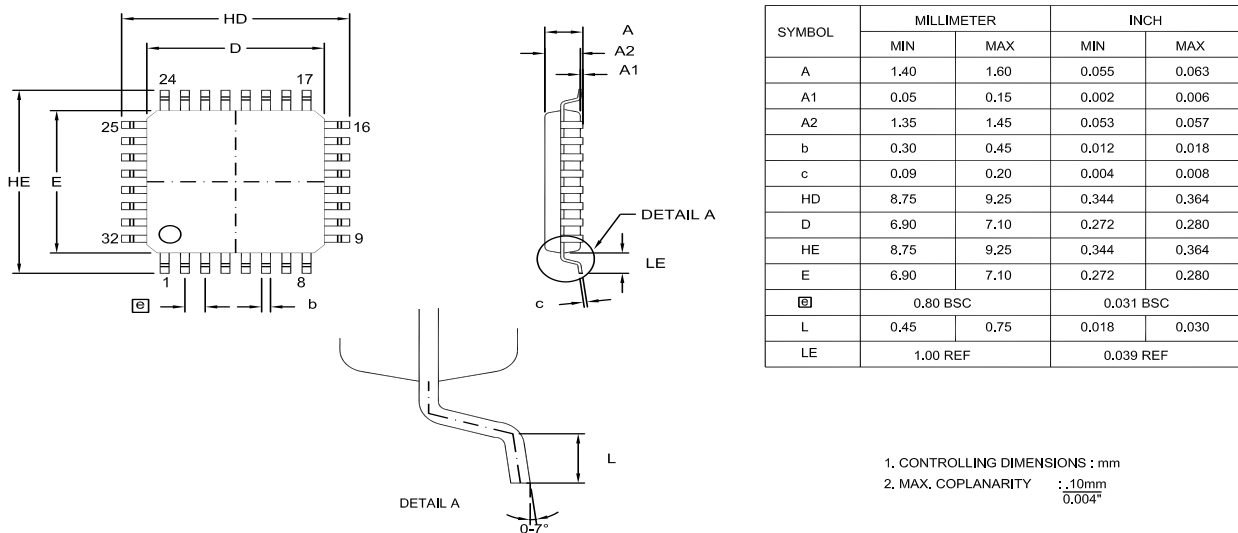

Figure 58. 32-Pin Low Quad Flat Package

Ordering Information

Table 167 identifies the basic features available for each device within the Z8FMC16100 Series Flash MCU product line. Table 168 provides ordering information for these products by part number. See Part Number Description on page 300 for a description of a part number’s unique identifying attributes.

Table 167. Z8FMC16100 Series Part Selection Guide

Product Feature	Z8FMC16100	Z8FMC08100	Z8FMC04100
Flash (KB)	16	8	4
SRAM (B)	512	512	512
General-Purpose I/O	17	17	17
Motor Control PWM Channels	6	6	6
ADC Inputs	8	8	8
Operational Amplifier	Yes	Yes	Yes
Comparator	Yes	Yes	Yes
16-bit Standard Timers w/ Capture, Compare, PWM	Yes	Yes	Yes
UART with support for LIN, and IrDA	Yes	Yes	Yes
I ² C or SPI Controller	Yes	Yes	Yes
Watchdog Timer	Yes	Yes	Yes
5.5296 MHz Internal Precision Oscillator	Yes	Yes	Yes

Each of the parts listed in Table 168 is shown in a lead-free package. The use of lead-free packaging adheres to a socially responsible environmental standard. To order the standard plastic (lead-soldered) package, contact [Customer Support](#).

Table 168. Ordering Information for the Z8FMC16100 Series Products*

Part Number	Flash KB (Bytes)	SRAM Bytes	GPIO	Max. Speed (MHz)	I ² C/SPI	Trimmed IPO	Package	Temp (°C)
Z8FMC16100 with 16 KB Flash and 512 B SRAM								
Z8FMC16100QKSG	16 (16,384)	512	17	20	I ² C/SPI	Y	QFN-32	0 to +70
Z8FMC16100QKEG								-40 to +105
Z8FMC16100AKSG	16 (16,384)	512	17	20	I ² C/SPI	Y	LQFP-32	0 to +70
Z8FMC16100AKEG								-40 to +105
Z8FMC08100 with 8 KB Flash and 512 B SRAM								
Z8FMC08100QKSG	8 (8,192)	512	17	20	I ² C/SPI	Y	QFN-32	0 to +70
Z8FMC08100QKEG								-40 to +105
Z8FMC08100AKSG	8 (8,192)	512	17	20	I ² C/SPI	Y	LQFP-32	0 to +70
Z8FMC08100AKEG								-40 to +105
Z8FMC04100 with 4 KB Flash and 512 B SRAM								
Z8FMC04100QKSG	4 (4,096)	512	17	20	I ² C/SPI	Y	QFN-32	0 to +70
Z8FMC04100QKEG								-40 to +105
Z8FMC04100AKSG	4 (4,096)	512	17	20	I ² C/SPI	Y	LQFP-32	0 to +70
Z8FMC04100AKEG								-40 to +105
Z8FMC16100 Series Development Kit								
Z8FMC160100KITG	Z8FMC16100 Series Development Kit							
Z8FMC161000ZEM	Z8 Encore! Z8FMC16100 Series In-Circuit Emulator Development Tool							
ZUSBOPTSC01ZAC	USB Opto-isolated Smart Cable Accessory Kit							
Note: *Factory-programmed versions of the devices in this table are available on request from Zilog®.								

For complete details on Z8FMC16100 Series Flash MCU, development tools and downloadable software, visit www.zilog.com.

Part Number Description

Zilog® part numbers consist of a number of components, as indicated in the following examples:

Example

Part number Z8FMC16100QKSG is a 16-bit Flash Motor Controller with 16 KB Program Memory in a QFN package with 32 pins, operating over a 0 °C to +70 °C temperature range and built using lead-free solder.

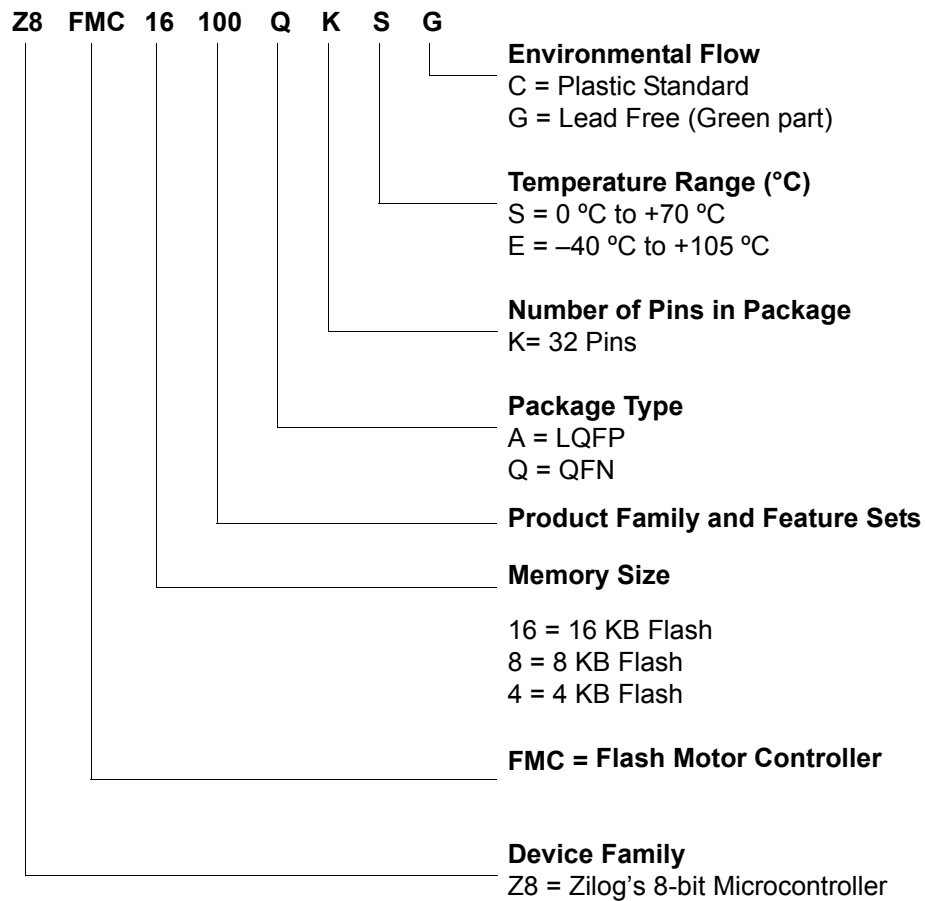

Appendix A—Register Tables

General Purpose RAM

Hex Addresses: 000–1FF

See [Register File](#) on page 11.

Hex Addresses: 200–EFF

Reserved

Timer 0

Hex Address: F00

Timer 0 High Byte Register (T0H)

BITS	7	6	5	4	3	2	1	0
FIELD	TH							
RESET	00H							
R/W	R/W							
ADDR	F00H							

Hex Address: F01

Timer 0 Low Byte Register (T0L)

BITS	7	6	5	4	3	2	1	0
FIELD	TL							
RESET	01H							
R/W	R/W							
ADDR	F01H							

Hex Address: F02

Timer 0 Reload High Byte Register (T0RH)

BITS	7	6	5	4	3	2	1	0
FIELD	TRH							
RESET	FFH							
R/W	R/W							
ADDR	F02H							

Hex Address: F03

Timer 0 Reload Low Byte Register (T0RL)

BITS	7	6	5	4	3	2	1	0
FIELD	TRL							
RESET	FF							
R/W	R/W							
ADDR	F03H							

Hex Address: F04

Timer 0 PWM High Byte Register (T0PWMH)

BITS	7	6	5	4	3	2	1	0
FIELD	PWMH							
RESET	00H							
R/W	R/W							
ADDR	F04H							

Hex Address: F05

Timer 0 PWM Low Byte Register (T0PWML)

BITS	7	6	5	4	3	2	1	0
FIELD	PWML							
RESET	00H							
R/W	R/W							
ADDR	F05H							

Hex Address: F06

Timer 0 Control 0 Register (T0CTL0)

BITS	7	6	5	4	3	2	1	0
FIELD	TMODE[3]	TICONFIG		TINSEL	PWMD			INCAP
RESET	0	00		0	000			0
R/W	R/W	R/W		R/W	R/W			R
ADDR	F06H							

Bit Position	Value (H)	Description
--------------	-----------	-------------

[7] TMODE[3]		<p>Timer Mode High Bit</p> <p>This bit along with the TMODE[2:0] field in the T0CTL1 register determines the operating mode of the timer. This is the most significant bit of the Timer mode selection value. See T0CTL1 register description for more details.</p>
-----------------	--	---

[6–5] TICONFIG		<p>Timer Interrupt Configuration—This field configures timer interrupt definitions. These bits affect all modes. The effect per mode is explained below:</p> <p>ONE SHOT, CONTINUOUS, COUNTER, PWM, COMPARE, DUAL PWM, TRIGGERED ONE-SHOT, COMPARATOR COUNTER:</p> <p>0x Timer interrupt occurs on reload. 10 Timer interrupts are disabled. 11 Timer Interrupt occurs on reload.</p> <p>GATED:</p> <p>0x Timer interrupt occurs on reload or inactive gate edge. 10 Timer interrupt occurs on inactive gate edge. 11 Timer interrupt occurs on reload.</p>
-------------------	--	--

(Continued)

Bit Position	Value (H)	Description
(Continued)		
CAPTURE, CAPTURE/COMPARE, CAPTURE RESTART: 0x Timer interrupt occurs on reload and capture. 10 Timer interrupt occurs on capture only. 11 Timer interrupt occurs on reload only		
[4] TINSEL	0 1	Timer Input Select Timer input is the Timer input pin. Timer input is the comparator output.
[3–1] PWMD		PWM Delay Value This field is a programmable delay to control the number of additional system clock cycles following a PWM or Reload compare before the Timer Output or the Timer Output Complement is switched to the active state. This field ensures a time gap between the deassertion of one PWM output to the assertion of its complement. 000 No delay 001 2 cycles delay 010 4 cycles delay 011 8 cycles delay 100 16 cycles delay 101 32 cycles delay 110 64 cycles delay 111 128 cycles delay
[0] INCAP	0 1	Input Capture Event Previous timer interrupt is not a result of a Timer Input Capture Event. Previous timer interrupt is a result of a Timer Input Capture Event.

Hex Address: F07

Timer 0 Control 1 Register (T0CTL1)

BITS	7	6	5	4	3	2	1	0
FIELD	TEN	TPOL	PRES			TMODE		
RESET	0	0	000			000		
R/W	R/W	R/W	R/W			R/W		
ADDR	F07H							

Bit Position	Value (H)	Description
[7] TEN	0	Timer is enabled. Timer is disabled.
	1	Timer is enabled.
[6] TPOL		<p>Timer Input/Output Polarity This bit is a function of the current operating mode of the timer. It determines the polarity of the input and/or output signal. When the timer is disabled, the Timer Output signal is set to the value of this bit.</p> <p>ONE-SHOT mode—If the timer is enabled the Timer Output signal pulses (changes state) for one system clock cycle after timer Reload.</p> <p>CONTINUOUS mode—If the timer is enabled the Timer Output signal is complemented after timer Reload.</p> <p>COUNTER mode—If the timer is enabled the Timer Output signal is complemented after timer reload. 0 = Count occurs on the rising edge of the Timer Input signal. 1 = Count occurs on the falling edge of the Timer Input signal.</p> <p>PWM SINGLE OUTPUT mode—When enabled, the Timer Output is forced to TPOL after PWM count match and forced back to TPOL after Reload.</p> <p>CAPTURE mode—If the timer is enabled the Timer Output signal is complemented after timer Reload. 0 = Count is captured on the rising edge of the Timer Input signal. 1 = Count is captured on the falling edge of the Timer Input signal.</p> <p>COMPARE mode—The Timer Output signal is complemented after timer Reload.</p> <p>GATED mode—The Timer Output signal is complemented after timer Reload. 0 = Timer counts when the Timer Input signal is High and interrupts are generated on the falling edge of the Timer Input. 1 = Timer counts when the Timer Input signal is Low and interrupts are generated on the rising edge of the Timer Input.</p> <p>CAPTURE/COMPARE mode—If the timer is enabled, the Timer Output signal is complemented after timer Reload 0 = Counting starts on the first rising edge of the Timer Input signal. The current count is captured on subsequent rising edges of the Timer Input signal. 1 = Counting starts on the first falling edge of the Timer Input signal. The current count is captured on subsequent falling edges of the Timer Input signal.</p>

(Continued)

Bit Position	Value (H)	Description
(Continued)		
		<p>PWM DUAL OUTPUT mode—If enabled, the Timer Output is set=$\overline{\text{TPOLE}}$ after PWM match and set=TPOLE after Reload. If enabled the Timer Output Complement takes on the opposite value of the Timer Output. The PWMD field in the T0CTL1 register determines an optional added delay on the assertion (Low to High) transition of both Timer Output and the Timer Output Complement for deadband generation.</p> <p>CAPTURE RESTART mode—If the timer is enabled the Timer Output signal is complemented after timer Reload. 0 = Count is captured on the rising edge of the Timer Input signal. 1 = Count is captured on the falling edge of the Timer Input signal.</p> <p>COMPARATOR COUNTER mode—If the timer is enabled the Timer Output signal is complemented after timer Reload. 0 = Count is captured on the rising edge of the Timer Input signal. 1 = Count is captured on the falling edge of the Timer Input signal.</p> <p>TRIGGERED ONE-SHOT mode—If the timer is enabled the Timer Output signal is complemented after timer Reload. 0 = The timer triggers on a Low to High transition on the input. 1 = The timer triggers on a High to Low transition on the input.</p>
[5–3] PRES		<p>The timer input clock is divided by 2^{PRES}, where PRES can be set from 0 to 7. The prescaler is reset each time the Timer is disabled. This insures proper clock division each time the Timer is restarted.</p>
	000	Divide by 1
	001	Divide by 2
	010	Divide by 4
	011	Divide by 8
	100	Divide by 16
	101	Divide by 32
	110	Divide by 64
	111	Divide by 128

Bit Position	Value (H)	Description
[2–0] TMODE[2:0]		This field along with the TMODE [3] bit in TOCTL0 register determines the operating mode of the timer. TMODE[3:0] selects from the following modes:
	0000	ONE-SHOT mode
	0001	CONTINUOUS mode
	0010	COUNTER mode
	0011	PWM SINGLE OUTPUT mode
	0100	CAPTURE mode
	0101	COMPARE mode
	0110	GATED mode
	0111	CAPTURE/COMPARE mode
	1000	PWM DUAL OUTPUT mode
	1001	CAPTURE RESTART mode
	1010	COMPARATOR COUNTER mode
	1011	TRIGGERED ONE-SHOT mode

Hex Address: F08

ADC Timer Capture High Byte Register (ADCTCAP_H)

BITS	7	6	5	4	3	2	1	0
FIELD	ADCTCAPH							
RESET	X							
R/W	R							
ADDR	F08H							

Bit Position	Value (H)	Description
[7:0]	00H–FFH	ADC Timer Capture Count High Byte The timer count is held in the data registers until the next ADC conversion is started.

Hex Address: F09

ADC Timer Capture Low Byte Register (ADCTCAP_L)

BITS	7	6	5	4	3	2	1	0
FIELD	ADCTCAPL							
RESET	X							
R/W	R							
ADDR	F09H							

Bit Position	Value (H)	Description
[7:0]	00H–FFH	ADC Timer Capture Count Low Byte The timer count is held in the data registers until the next ADC conversion is started.

Hex Address: F0A–F1F

Reserved

Pulse Width Modulator

Hex Address: F20

PWM Control 0 Register (PWMCTL0)

BITS	7	6	5	4	3	2	1	0
FIELD	PWMOFF	OUTCTL	ALIGN	Reserved	ADCTRIG	Reserved	READY	PWMEN
RESET	0	0	0	0	0	0	0	0
R/W	R/W	R/W	R/W	R/W	R/W	R/W	R/W	R/W
ADDR	F20H							

Bit Position	Value (H)	Description
[7] PWMOFF	0	Place PWM outputs in off-state Disable modulator control of PWM pins. Outputs are in predefined off-state. This is not dependent on the reload event.
	1	Re-enable modulator control of PWM pins at next PWM reload event.
[6] OUTCTL	0	PWM Output Control PWM outputs are controlled by the Pulse Width Modulator.
	1	PWM outputs selectively disabled (set to off-state) according to values in the OUTx bits of the PWMOUT register.
[5] ALIGN	0	PWM Edge Alignment PWM outputs are edge aligned.
	1	PWM outputs are center aligned.
[4] Reserved		Reserved
[3] ADCTRIG	0	ADC Trigger Enable No ADC trigger pulses.
	1	ADC trigger enabled.
[2] Reserved	0	Reserved
[1] READY	0	Values Ready for Next Reload Event PWM values (pre-scale, period, and duty cycle) are not ready. Do not use values in holding registers at next PWM reload event.
	1	PWM values (pre-scale, period, and duty cycle) are ready. Transfer all values from temporary holding registers to working registers at next PWM reload event.
[0] PWMEN	0	PWM Enable PWM is disabled and enabled PWM output pins are forced to default off-state. PWM master counter is stopped. Certain control registers may only be written in this state.
	1	PWM is enabled and PWM output pins are enabled as outputs.

Hex Address: F21

PWM Control 1 Register (PWMCTL1)

BITS	7	6	5	4	3	2	1	0
FIELD	RLFREQ[1:0]		INDEN	Pol45	Pol23	Pol10	PRES[1:0]	
RESET	00		0	0	0	0	00	
R/W	R/W		R/W	R/W	R/W	R/W	R/W	
ADDR	F21H							

Bit Position	Value (H)	Description
[7:6] RLFREQ[1:0]		Reload Event Frequency This bit field is buffered. Changes to the reload event frequency takes effect at the end of the current PWM period. Reads always return the bit values from the temporary holding register.
	00	PWM reload event occurs at the end of every PWM period.
	01	PWM reload event occurs once every 2 PWM periods.
	10	PWM reload event occurs once every 4 PWM periods.
	11	PWM reload event occurs once every 8 PWM periods.
[5] INDEN	0	Independent PWM Mode Enable This bit may only be altered when <i>PWEN</i> (PWMCTL0) cleared. PWM outputs operate as 3 complementary pairs.
	1	PWM outputs operate as 6 independent channels.
[4] Pol2	1	Invert Output polarity for channel pair PWM2.
	0	Non-inverted polarity for channel pair PWM2.
[3] Pol1	1	Invert Output polarity for channel pair PWM1.
	0	Non-inverted polarity for channel pair PWM1.
[2] Pol0	1	Invert Output polarity for channel pair PWM0.
	0	Non-inverted polarity for channel pair PWM0.
[1:0] PRES		PWM Prescaler The prescaler divides down the PWM input clock (either the system clock or the <i>PWMIN</i> external input). This field is buffered. Changes to this field take effect at the next PWM reload event. Reads always return the values from the temporary holding register.
	00	Divide by 1
	01	Divide by 2
	10	Divide by 4
	11	Divide by 8

Hex Address: F22

PWM DeadBand Register (PWMDDB)

BITS	7	6	5	4	3	2	1	0
FIELD	PWMDDB[7:0]							
RESET	01H							
R/W	R/W							
ADDR	F22H							

Bit Position	Value (H)	Description
--------------	-----------	-------------

[7:0] PWMDDB		PWM Deadband Sets the PWM deadband period for which both PWM outputs of a complementary PWM output pair are deasserted.
-----------------	--	--

Note: This register can only be written when `PWEN` is cleared.

Hex Address: F23

PWM Minimum Pulse Width Filter (PWMMPF)

BITS	7	6	5	4	3	2	1	0
FIELD	PWMMPF[7:0]							
RESET	00H							
R/W	R/W							
ADDR	F23H							

Bit Position	Value (H)	Description
--------------	-----------	-------------

[7:0] PWMMPF		PWM Minimum Pulse Filter Sets the minimum allowed output pulse width in PWM clock cycles.
-----------------	--	---

Note: This register can only be written when `PWEN` is cleared.

Hex Address: F24

PWM Fault Mask Register (PWMFM)

BITS	7	6	5	4	3	2	1	0
FIELD	Reserved		DBGMSK	Reserved		F1MASK	COMASK	FMASK
RESET	00		0	000		0	0	0
R/W	R		R/W	R		R/W	R/W	R/W
ADDR	F24H							

Bit Position	Value (H)	Description
--------------	-----------	-------------

[7:6] Reserved		Must be 0.
-------------------	--	------------

[5] DBGMSK	0	Debug Entry Fault Mask Entering CPU DEBUG Mode generates a PWM fault.
	1	Entering CPU DEBUG mode does not generate a PWM fault.

[4:3] Reserved		Must be 0.
-------------------	--	------------

[2] F1MASK	0	Fault1 Fault Mask <u>Fault1</u> generates a PWM fault.
	1	<u>Fault1</u> does not generate a PWM fault.

[1] COMASK	0	Comparator Fault Mask Comparator generates a PWM fault.
	1	Comparator does not generate a PWM fault.

[0] F0MASK	0	Fault Pin Mask <u>Fault0</u> pin generates a PWM fault.
	1	<u>Fault0</u> pin does not generate a PWM fault.

Note: This register can only be written when `PWEN` is cleared.

Hex Address: F25

PWM Fault Status Register (PWMFSTAT)

BITS	7	6	5	4	3	2	1	0
FIELD	RLDFlag	Reserved	DBGFLAG	Reserved		F1FLAG	C0FLAG	FFLAG
RESET	U	0	U	00		U	U	U
R/W	R/W1C	R	R/W1C	R		R/W1C	R/W1C	R/W1C
ADDR	F25H							

Bit Position	Value (H)	Description
[7] RLDFlag		Reload Flag This bit is set and latched when a PWM timer reload occurs. Writing a 1 to this bit clears the flag.
[6] Reserved	0	Reserved Always reads 0.
[5] DBGFLAG		Debug Flag This bit is set and latched when DEBUG mode is entered. Writing a 1 to this bit clears the flag.
[4:3] Reserved	0	Reserved Always reads 0.
[2] F1FLAG		Fault1 Flag This bit is set and latched when $\overline{\text{Fault1}}$ is asserted. Writing a 1 to this bit clears the flag.
[1] C0FLAG		Comparator 0 Flag This bit is set and latched when Comparator is asserted. Writing a 1 to this bit clears the flag.
[0] FFLAG		Fault Flag This bit is set and latched when the $\overline{\text{FAULT0}}$ input is asserted. Writing a 1 to this bit clears the flag.

Note: For this register, W1C means you must write one to clear the flag.

Hex Address: F26

PWM Input Sample Register (PWMIN)

BITS	7	6	5	4	3	2	1	0
FIELD	Reserved	FAULT	IN2H	IN2L	IN1H	IN1L	IN0H	IN0L
RESET	0	0	0	0	0	0	0	0
R/W	R	R/W	R/W	R/W	R/W	R/W	R/W	R/W
ADDR	F26H							

Bit Position	Value (H)	Description
--------------	-----------	-------------

[7] Reserved		Must be 0.
-----------------	--	------------

[6] FAULT	0	Sample Fault0 pin A Low level signal was read on the FAULT pin.
	1	A High level signal was read on the FAULT pin.

[5:0] IN2H/IN2L/ IN1H/IN1L/ IN0H/IN0L	0	Sample PWM pins A Low level signal was read on the pins.
	1	A High level signal was read on the pins.

Hex Address: F27

PWM Output Control Register (PWMOUT)

BITS	7	6	5	4	3	2	1	0
FIELD	Reserved	Reserved	OUT2L	OUT2H	OUT1L	OUT1H	OUT0L	OUT0H
RESET	0	0	0	0	0	0	0	0
R/W	R	R	R/W	R/W	R/W	R/W	R/W	R/W
ADDR	F27H							

Bit Position	Value (H)	Description
[7,6] Reserved		Must be 0.
[5, 3, 1] OUT2L/ OUT1L/ OUT0L	0	PWM 2L/1L/0L Output Configuration PWM 2L/1L/0L output signal is enabled and controlled by PWM.
	1	PWM 2L/1L/0L output signal is in low-side off-state.
[4, 2, 0] OUT2H/ OUT1H/ OUT0H	0	PWM 2H/1H/0H Output Configuration PWM 2H/1H/0H output signal is enabled and controlled by PWM.
	1	PWM 2H/1H/0H output signal is in high-side off-state.

Hex Address: F28

PWM Fault Control Register (PWMFCTL)

BITS	7	6	5	4	3	2	1	0
FIELD	Reserved	DBG RST	Fault1INT	Fault1RST	CMP0INT	CMP0RST	Fault0INT	Fault0RST
RESET	0	0	0	0	0	0		
R/W	R/W	R/W	R/W	R/W	R/W	R/W	R/W	R/W
ADDR	F28H							

Bit Position	Value (H)	Description
[7] Reserved	0	Reserved.
[6] DBG RST	0	DebugRestart Automatic recovery. PWM resumes control of outputs when all fault sources have deasserted and a new PWM period begins.
	1	Software controlled recovery. PWM resumes control of outputs only after all fault sources have deasserted and all fault flags are cleared and a PWM reload occurs.
[5] Fault1INT	0	Fault1 Interrupt Interrupt on comparator assertion disabled.
	1	Interrupt on comparator assertion enabled.

Bit Position	Value (H)	Description
[4] Fault1RST	0	Fault1 Restart Automatic recovery. PWM resumes control of outputs when all fault sources have deasserted.
	1	Software controlled recovery. PWM resumes control of outputs only after all fault sources have deasserted and all fault flags are cleared and a PWM reload occurs.
[3] CMP0INT	0	Comparator 0 Interrupt Interrupt on comparator 0 assertion disabled.
	1	Interrupt on comparator 0 assertion enabled.
[2] CMP0RST	0	Comparator 0 Restart Automatic recovery. PWM resumes control of outputs when all fault sources have deasserted.
	1	Software controlled recovery. PWM resumes control of outputs only after all fault sources have deasserted and all fault flags are cleared and a PWM reload occurs.
[1] Fault0INT	0	Fault0 Interrupt Interrupt on $\overline{\text{Fault0}}$ pin assertion disabled.
	1	Interrupt on $\overline{\text{Fault0}}$ pin assertion enabled.
[0] Fault0RST	0	Fault0 Restart Automatic recovery. PWM resumes control of outputs when all fault sources have deasserted.
	1	Software controlled recovery. PWM resumes control of outputs only after all fault sources have deasserted and all fault flags are cleared and a PWM reload occurs.

Note: This register can only be written when PWEN is cleared.

Hex Address: F29

Current-Sense Trigger Control Register (PWMSHC)

BITS	7	6	5	4	3	2	1	0
FIELD	CSTPOL	HEN	NHEN	LEN	NLEN	CSTPWM2	CSTPWM1	CSTPWM0
RESET	0	0	0	0	0	0	0	0
R/W	R/W	R/W	R/W	R/W	R/W	R/W	R/W	R/W
ADDR	F29H							

Bit Position	Value (H)	Description
[7] CSTPOL	0	Sample Hold Polarity Hold when terms are active
	1	Hold when terms are not active
[6] HEN	0	High Side Active enable Ignore Product of PWMH0, PWMH1, and PWMH2 in Sample/Hold equation
	1	Hold when PWMH0, PWMH1, and PWMH2 are all active
[5] NHEN	0	High Side inactive enable Ignore Product of $\overline{\text{PWMH0}}$, $\overline{\text{PWMH1}}$, and $\overline{\text{PWMH2}}$ in Sample/Hold equation
	1	Hold when are all active
[4] LEN	0	Low Side Active enable Ignore Product of PWML0, PWML1, and PWML2 in Sample/Hold equation
	1	Hold when PWML0, PWML1, and PWML2 are all active
[3] NLEN	0	Low Side Inactive enable Ignore Product of $\overline{\text{PWML0}}$, $\overline{\text{PWML1}}$, and $\overline{\text{PWML2}}$ in Sample/Hold equation
	1	Hold when $\overline{\text{PWML0}}$, $\overline{\text{PWML1}}$, and $\overline{\text{PWML2}}$ are all active
[2] CSTPWM2	0	PWM Channel2 Sample/Hold Enable Channel 2 terms are not used in Sample/Hold Equation
	1	Channel 2 terms are used in Sample/Hold Equation
[1] CSTPWM1	0	PWM Channel1 Sample/Hold Enable Channel 1 terms are not used in Sample/Hold Equation
	1	Channel 1 terms are used in Sample/Hold Equation
[0] CSTPWM0	0	PWM Channel0 Sample/Hold Enable Channel 0 terms are not used in Sample/Hold Equation
	1	Channel 0 terms are used in Sample/Hold Equation

Hex Address: F2A–B

Reserved

Hex Address: F2C

PWM High Byte Register (PWMH)

BITS	7	6	5	4	3	2	1	0
FIELD	Reserved				PWMH			
RESET	0H				0H			
R/W	R/W				R/W			
ADDR	F2CH							

Hex Address: F2D

PWM Low Byte Register (PWML)

BITS	7	6	5	4	3	2	1	0
FIELD	PWML							
RESET	01H							
R/W	R/W							
ADDR	F2DH							

Hex Address: F2E

PWM Reload High Byte Register (PWMRH)

BITS	7	6	5	4	3	2	1	0
FIELD	Reserved				PWMRH			
RESET	0H				FH			
R/W	R/W				R/W			
ADDR	F2EH							

Hex Address: F2F

PWM Reload Low Byte Register (PWMRL)

BITS	7	6	5	4	3	2	1	0
FIELD	PWMRL							
RESET	FF							
R/W	R/W							
ADDR	F2FH							

Hex Address: F30

PWM 0-2 H/L Duty Cycle High Byte Register (PWMHxDH, PWMLxDH)

BITS	7	6	5	4	3	2	1	0
FIELD	SIGN	Reserved		DUTYH				
RESET	0	00		0_0000				
R/W	R/W	R/W		R/W				
ADDR	F30H, F32H, F34H, F36H, F38H, F3AH							

Hex Address: F31

PWM 0-2 H/L Duty Cycle Low Byte Register (PWMHxDL, PWMLxDL)

BITS	7	6	5	4	3	2	1	0
FIELD	DUTYL							
RESET	00H							
R/W	R/W							
ADDR	F31H, F33H, F35H, F37H, F39H, F3BH							

Bit Position	Value (H)	Description
[7] SIGN	0	Duty Cycle Sign Duty Cycle is a positive two's complement number.
	1	Duty Cycle is a negative two's complement number. Output is forced to the off-state.
[6:0], [7:0] DUTYH and DUTYL		PWM Duty Cycle High and Low Bytes These two bytes, {DUTYH[7:0], DUTYL[7:0]}, form a 14-bit signed value (Bits 5 and 6 of the High Byte are always 0). The value is compared to the current 12-bit PWM count.

Hex Address: F32

PWM 0-2 H/L Duty Cycle High Byte Register (PWMHxDH, PWMLxDH)

BITS	7	6	5	4	3	2	1	0
FIELD	SIGN	Reserved		DUTYH				
RESET	0	00		0_0000				
R/W	R/W	R/W		R/W				
ADDR	F30H, F32H, F34H, F36H, F38H, F3AH							

Hex Address: F33

PWM 0-2 H/L Duty Cycle Low Byte Register (PWMHxDL, PWMLxDL)

BITS	7	6	5	4	3	2	1	0
FIELD	DUTYL							
RESET	00H							
R/W	R/W							
ADDR	F31H, F33H, F35H, F37H, F39H, F3BH							

Bit Position	Value (H)	Description
[7] SIGN	0	Duty Cycle Sign Duty Cycle is a positive two's complement number.
	1	Duty Cycle is a negative two's complement number. Output is forced to the off-state.
[6:0], [7:0] DUTYH and DUTYL		PWM Duty Cycle High and Low Bytes These two bytes, {DUTYH[7:0], DUTYL[7:0]}, form a 14-bit signed value (Bits 5 and 6 of the High Byte are always 0). The value is compared to the current 12-bit PWM count.

Hex Address: F34

PWM 0-2 H/L Duty Cycle High Byte Register (PWMHxDH, PWMLxDH)

BITS	7	6	5	4	3	2	1	0
FIELD	SIGN	Reserved			DUTYH			
RESET	0	00			0_0000			
R/W	R/W	R/W			R/W			
ADDR	F30H, F32H, F34H, F36H, F38H, F3AH							

Hex Address: F35

PWM 0-2 H/L Duty Cycle Low Byte Register (PWMHxDL, PWMLxDL)

BITS	7	6	5	4	3	2	1	0
FIELD	DUTYL							
RESET	00H							
R/W	R/W							
ADDR	F31H, F33H, F35H, F37H, F39H, F3BH							

Bit Position	Value (H)	Description
[7] SIGN	0	Duty Cycle Sign Duty Cycle is a positive two's complement number.
	1	Duty Cycle is a negative two's complement number. Output is forced to the off-state.
[6:0], [7:0] DUTYH and DUTYL		PWM Duty Cycle High and Low Bytes These two bytes, {DUTYH[7:0], DUTYL[7:0]}, form a 14-bit signed value (Bits 5 and 6 of the High Byte are always 0). The value is compared to the current 12-bit PWM count.

Hex Address: F36

PWM 0-2 H/L Duty Cycle High Byte Register (PWMHxDH, PWMLxDH)

BITS	7	6	5	4	3	2	1	0
FIELD	SIGN	Reserved			DUTYH			
RESET	0	00			0_0000			
R/W	R/W	R/W			R/W			
ADDR	F30H, F32H, F34H, F36H, F38H, F3AH							

Hex Address: F37

PWM 0-2 H/L Duty Cycle Low Byte Register (PWMHxDL, PWMLxDL)

BITS	7	6	5	4	3	2	1	0
FIELD	DUTYL							
RESET	00H							
R/W	R/W							
ADDR	F31H, F33H, F35H, F37H, F39H, F3BH							

Bit Position	Value (H)	Description
[7] SIGN	0	Duty Cycle Sign Duty Cycle is a positive two's complement number.
	1	Duty Cycle is a negative two's complement number. Output is forced to the off-state.
[6:0], [7:0] DUTYH and DUTYL		PWM Duty Cycle High and Low Bytes These two bytes, {DUTYH[7:0], DUTYL[7:0]}, form a 14-bit signed value (Bits 5 and 6 of the High Byte are always 0). The value is compared to the current 12-bit PWM count.

Hex Address: F38

PWM 0-2 H/L Duty Cycle High Byte Register (PWMHxDH, PWMLxDH)

BITS	7	6	5	4	3	2	1	0
FIELD	SIGN	Reserved			DUTYH			
RESET	0	00			0_0000			
R/W	R/W	R/W			R/W			
ADDR	F30H, F32H, F34H, F36H, F38H, F3AH							

Hex Address: F39

PWM 0-2 H/L Duty Cycle Low Byte Register (PWMHxDL, PWMLxDL)

BITS	7	6	5	4	3	2	1	0
FIELD	DUTYL							
RESET	00H							
R/W	R/W							
ADDR	F31H, F33H, F35H, F37H, F39H, F3BH							

Bit Position	Value (H)	Description
[7] SIGN	0	Duty Cycle Sign Duty Cycle is a positive two's complement number.
	1	Duty Cycle is a negative two's complement number. Output is forced to the off-state.
[6:0], [7:0] DUTYH and DUTYL		PWM Duty Cycle High and Low Bytes These two bytes, {DUTYH[7:0], DUTYL[7:0]}, form a 14-bit signed value (Bits 5 and 6 of the High Byte are always 0). The value is compared to the current 12-bit PWM count.

Hex Address: F3A

PWM 0-2 H/L Duty Cycle High Byte Register (PWMHxDH, PWMLxDH)

BITS	7	6	5	4	3	2	1	0
FIELD	SIGN	Reserved			DUTYH			
RESET	0	00			0_0000			
R/W	R/W	R/W			R/W			
ADDR	F30H, F32H, F34H, F36H, F38H, F3AH							

Hex Address: F3B

PWM 0-2 H/L Duty Cycle Low Byte Register (PWMHxDL, PWMLxDL)

BITS	7	6	5	4	3	2	1	0
FIELD	DUTYL							
RESET	00H							
R/W	R/W							
ADDR	F31H, F33H, F35H, F37H, F39H, F3BH							

Bit Position	Value (H)	Description
[7] SIGN	0	Duty Cycle Sign Duty Cycle is a positive two's complement number.
	1	Duty Cycle is a negative two's complement number. Output is forced to the off-state.
[6:0], [7:0] DUTYH and DUTYL		PWM Duty Cycle High and Low Bytes These two bytes, {DUTYH[7:0], DUTYL[7:0]}, form a 14-bit signed value (Bits 5 and 6 of the High Byte are always 0). The value is compared to the current 12-bit PWM count.

Hex Addresses: F3C–F3F

Reserved

LIN-UART

Hex Address: F40

LIN-UART Transmit Data Register (U0TXD)

BITS	7	6	5	4	3	2	1	0
FIELD	TXD							
RESET	X							
R/W	W							
ADDR	F40H							

LIN-UART Receive Data Register (U0RXD)

BITS	7	6	5	4	3	2	1	0
FIELD	RXD							
RESET	X							
R/W	R							
ADDR	F40H							

Hex Address: F41

LIN-UART Status 0 Register - standard UART mode (U0STAT0)

BITS	7	6	5	4	3	2	1	0
FIELD	RDA	PE	OE	FE	BRKD	TDRE	TXE	CTS
RESET	0	0	0	0	0	1	1	X
R/W	R	R	R	R	R	R	R	R
ADDR	F41H							

Hex Address: F42

LIN-UART Control 0 Register (U0CTL0)

BITS	7	6	5	4	3	2	1	0
FIELD	TEN	REN	CTSE	PEN	PSEL	SBRK	STOP	LBEN
RESET	0	0	0	0	0	0	0	0
R/W	R/W	R/W	R/W	R/W	R/W	R/W	R/W	R/W
ADDR	F42H							

Hex Address: F43

MultiProcessor Control Register (U0CTL1 with MSEL = 000b)

BITS	7	6	5	4	3	2	1	0
FIELD	MPMD[1]	MPEN	MPMD[0]	MPBT	DEPOL	BRGCTL	RDAIRQ	IREN
RESET	0	0	0	0	0	0	0	0
R/W	R/W	R/W	R/W	R/W	R/W	R/W	R/W	R/W
ADDR	F43H with MSEL = 000b							

Hex Address: F44

LIN-UART Mode Select and Status Register (U0MDSTAT)

BITS	7	6	5	4	3	2	1	0
FIELD	MSEL			Mode Status				
RESET	0	0	0	0	0	0	0	0
R/W	R/W	R/W	R/W	R	R	R	R	R
ADDR	F44H							

Hex Address: F45

LIN-UART Address Compare Register (U0ADDR)

BITS	7	6	5	4	3	2	1	0
FIELD	COMP_ADDR							
RESET	00H							
R/W	R/W							
ADDR	F45H							

Hex Address: F46

LIN-UART Address Compare Register (U0ADDR)

BITS	7	6	5	4	3	2	1	0
FIELD	COMP_ADDR							
RESET	00H							
R/W	R/W							
ADDR	F45H							

Hex Address: F47

LIN-UART Baud Rate Low Byte Register (U0BRL)

BITS	7	6	5	4	3	2	1	0
FIELD	BRL							
RESET	FFH							
R/W	R/W							
ADDR	F47H							

Hex Addresses: F48–F5F

Reserved

I²C

Hex Address: F50

I²C Data Register (I2CDATA)

BITS	7	6	5	4	3	2	1	0
FIELD	DATA							
RESET	0							
R/W	R/W							
ADDR	F50H							

Hex Address: F51

I²C Interrupt Status Register (I2CISTAT)

BITS	7	6	5	4	3	2	1	0
FIELD	TDRE	RDRF	SAM	GCA	RD	ARBLST	SPRS	NCKI
RESET	1	0	0	0	0	0	0	0
R/W	R	R	R	R	R	R	R	R
ADDR	F51H							

Hex Address: F52

I²C Control Register (I2CCTL)

BITS	7	6	5	4	3	2	1	0
FIELD	IEN	START	STOP	BIRQ	TXI	NAK	FLUSH	FILTEN
RESET	0	0	0	0	0	0	0	0
R/W	R/W	R/W1	R/W1	R/W	R/W	R/W1	R/W	R/W
ADDR	F52H							

Hex Address: F53

I²C Baud Rate High Byte Register (I2CBRH)

BITS	7	6	5	4	3	2	1	0
FIELD	BRH							
RESET	FFH							
R/W	R/W							
ADDR	F53H							

Hex Address: F54

I²C Baud Rate Low Byte Register (I2CBRL)

BITS	7	6	5	4	3	2	1	0
FIELD	BRL							
RESET	FFH							
R/W	R/W							
ADDR	F54H							

Hex Address: F55

I²C State Register (I2CSTATE) - Description when DIAG = 0

BITS	7	6	5	4	3	2	1	0
FIELD	ACKV	ACK	AS	DS	10B	RSTR	SCLOUT	BUSY
RESET	0	0	0	0	0	0	X	X
R/W	R	R	R	R	R	R	R	R
ADDR	F55H							

I²C State Register (I2CSTATE) - Description when DIAG = 1

BITS	7	6	5	4	3	2	1	0
FIELD	I2CSTATE_H				I2CSTATE_L			
RESET	0	0	0	0	0	0	0	0
R/W	R	R	R	R	R	R	R	R
ADDR	F55H							

Hex Address: F56

I²C Mode Register (I2CMODE)

BITS	7	6	5	4	3	2	1	0
FIELD	Reserved	MODE[1:0]		IRM	GCE	SLA[9:8]		DIAG
RESET	0	0		0	0	0		0
R/W	R	R/W		R/W	R/W	R/W		R/W
ADDR	F56H							

Hex Address: F57

I²C Slave Address Register (I2CSLVAD)

BITS	7	6	5	4	3	2	1	0
FIELD	SLA[7:0]							
RESET	00H							
R/W	R/W							
ADDR	F57H							

Hex Addresses: F58–F5F

Reserved

SPI

Hex Address: F60

SPI Data Register (SPIDATA)

BITS	7	6	5	4	3	2	1	0
FIELD	DATA							
RESET	X							
R/W	R/W							
ADDR	F60H							

Hex Address: F61

SPI Control Register (SPICTL)

BITS	7	6	5	4	3	2	1	0
FIELD	IRQE	STR	BIRQ	PHASE	CLKPOL	WOR	MMEN	SPIEN
RESET	00H							
R/W	R/W							
ADDR	F61H							

Hex Address: F62

SPI Status Register (SPISTAT)

BITS	7	6	5	4	3	2	1	0
FIELD	IRQ	OVR	COL	ABT	Reserved		TXST	SLAS
RESET	0	0	0	0	0	0	0	1
R/W	R/W*				R			
ADDR	F62H							
R/W* = Read access. Write a 1 to clear the bit to 0.								

Hex Address: F63

SPI Mode Register (SPIMODE)

BITS	7	6	5	4	3	2	1	0
FIELD	Reserved		DIAG	NUMBITS[2:0]			SSIO	SSV
RESET	00H							
R/W	R		R/W					
ADDR	F63H							

Hex Address: F64

SPI Diagnostic State Register (SPIDST)

BITS	7	6	5	4	3	2	1	0
FIELD	SCKEN	TCKEN	SPISTATE					
RESET	00H							
R/W	R							
ADDR	F64H							

Hex Address: F65

Reserved

Hex Address: F66

SPI Baud Rate High Byte Register (SPIBRH)

BITS	7	6	5	4	3	2	1	0
FIELD	BRH							
RESET	FFH							
R/W	R/W							
ADDR	F66H							

Hex Address: F67

SPI Baud Rate Low Byte Register (SPIBRL)

BITS	7	6	5	4	3	2	1	0
FIELD	BRL							
RESET	FFH							
R/W	R/W							
ADDR	F67H							

Hex Addresses: F68–F6F

Reserved

Analog-to-Digital Converter

Hex Address: F70

ADC Control Register 0 (ADCCTL0)

BITS	7	6	5	4	3	2	1	0
FIELD	START	Reserved	REFEN	ADCEN	Reserved	ANAIN[2:0]		
RESET	0	0	0	0	0	0	0	0
R/W	R/W1	R/W	R/W	R/W	R/W	R/W	R/W	R/W
ADDR	F70H							

Bit Position	Value (H)	Description
--------------	-----------	-------------

[7] START	0	<u>ADC Start / Busy</u> Writing to 0 has no effect. Reading a 0 indicates the ADC is available to begin a conversion.
	1	Writing to 1 starts a conversion. Reading a 1 indicates a conversion is currently in progress.
[6]	0	Reserved—Must Be 0.

[5] REFEN	0	Reference Enable Internal reference voltage is disabled allowing an external reference voltage to be used by the ADC.
	1	Internal reference voltage for the ADC is enabled. The internal reference voltage can be measured on the VREF pin.
[4] ADCEN	0	ADC Enable ADC is disabled for low power operation.
	1	ADC is enabled for normal use.
[3] Reserved	0	Reserved—Must Be 0.
[2:0] ANAIN	000	Analog Input Select ANA0 input is selected for analog to digital conversion.
	001	ANA1 input is selected for analog to digital conversion.
	010	ANA2 input is selected for analog to digital conversion.
	011	ANA3 input is selected for analog to digital conversion.
	100	ANA4 input is selected for analog to digital conversion.
	101	ANA5 input is selected for analog to digital conversion.
	110	ANA6 input is selected for analog to digital conversion.
	111	ANA7 input is selected for analog to digital conversion.

Hex Address: F71

ADC Raw Data High Byte Register (ADCRD_H)

BITS	7	6	5	4	3	2	1	0
FIELD	ADCRDH							
RESET	X							
R/W	R							
ADDR	F71H							

Bit Position	Value (H)	Description
[7:0]	00H–FFH	ADC Raw Data High Byte The data in this register is the raw data coming from the SAR Block. It will change as the conversion is in progress. This register is used for testing only.

Hex Address: F72

ADC Raw Data High Byte Register (ADCRD_H)

BITS	7	6	5	4	3	2	1	0
FIELD	ADCRDH							
RESET	X							
R/W	R							
ADDR	F71H							

Bit Position	Value (H)	Description
[7:0]	00H–FFH	ADC Raw Data High Byte The data in this register is the raw data coming from the SAR Block. It will change as the conversion is in progress. This register is used for testing only.

Hex Address: F73

ADC Data Low Bits Register (ADCD_L)

BITS	7	6	5	4	3	2	1	0
FIELD	ADCDL		Reserved					
RESET	X		X					
R/W	R		R					
ADDR	F73H							

Bit Position	Value (H)	Description
[7:6]	00–11b	ADC Low Bits These bits are the 2 least significant bits of the 10-bit ADC output. These bits are undefined after a Reset. The low bits are latched into this register whenever the ADC Data High Byte register is read.
[5:0] Reserved	0	Reserved—Must Be 0.

Hex Address: F74

Sample and Settling Time (ADCSST)

BITS	7	6	5	4	3	2	1	0
FIELD	Reserved				SST			
RESET	0				1	1	1	1
R/W	R				R/W			
ADDR	F74H							

Bit Position	Value (H)	Description
[7:4]	0H	Reserved - Must be 0.
[3:0] SST	0H - FH	Sample settling time in number of system clock periods to meet 0.5 uS minimum.

Hex Address: F75

Sample Hold Time (ADCST)

BITS	7	6	5	4	3	2	1	0
FIELD	Reserved		ST					
RESET	0		1	1	1	1	1	1
R/W	R/W		R/W					
ADDR	F75H							

Bit Position	Value (H)	Description
[7:5]	0H	Reserved - Must be 0.
[4:0] SHT	0H - FH	Sample Hold time in number of system clock periods to meet 1 uS minimum.

Hex Address: F76

ADC Clock Prescale Register (ADCCP)

BITS	7	6	5	4	3	2	1	0
FIELD	Reserved				DIV16	DIV8	DIV4	DIV2
RESET	0				0	0	0	0
R/W	R/W							
ADDR	F76H							

Bit Position	Value (H)	Description
[0] DIV2	0	DIV2 Clock is not divided
	1	System Clock is divided by 2 for ADC Clock
[1] DIV4	0	DIV4 Clock is not divided
	1	System Clock is divided by 4 for ADC Clock
[2] DIV8	0	DIV8 Clock is not divided
	1	System Clock is divided by 8 for ADC Clock
[3] DIV16	0	DIV16 Clock is not divided
	1	System Clock is divided by 16 for ADC Clock
[7:4]	0H	Reserved - must be 0.

Hex Addresses: F77–F85

Reserved

Oscillator Control

Hex Address: F86

Oscillator Control Register (OSCCTL)

BITS	7	6	5	4	3	2	1	0
FIELD	INTEN	XTLEN	WDTEN	POFEN	WDFEN	FLPEN	SCKSEL	
RESET	1	0	1	0	0	0*	00	
R/W	R/W	R/W	R/W	R/W	R/W	R/W	R/W	
ADDR	F86H							
* The reset value is 1 if the option bit LPDEN is 0.								

Bit Position	Value (H)	Description
[7] INTEN	0	Internal Precision Oscillator Enable Internal precision oscillator is disabled.
	1	Internal precision oscillator is enabled.
[6] XTLEN	0	Crystal Oscillator Enable Crystal oscillator is disabled.
	1	Crystal oscillator is enabled.
[5] WDTEN	0	Watchdog Timer Oscillator Enable Watchdog Timer oscillator is disabled
	1	Watchdog Timer oscillator is enabled
[4] POFEN	0	Primary Oscillator Failure Detection Enable Failure detection and recovery of primary oscillator is disabled. This bit is cleared automatically if a primary oscillator failure is detected.
	1	Failure detection and recovery of primary oscillator is enabled
[3] WDFEN	0	Watchdog Timer Oscillator Failure Detection Enable Failure detection of Watchdog Timer oscillator is disabled. This bit is cleared automatically if a Watchdog Timer oscillator failure is detected.
	1	Failure detection of Watchdog Timer oscillator is enabled

Bit Position	Value (H)	Description
[2] FLPEN	0	Flash Low Power Mode Enable Flash Low Power Mode is disabled.
	1	Flash Low Power Mode is enabled. The Flash will be powered down during idle periods of the clock and powered up during Flash reads. This bit should only be set if the frequency of the primary oscillator source is 8 MHz or lower. The reset value of this bit is controlled by the <code>LPDEN</code> option bit during reset.
[1:0] SCKSEL	00	System Clock Oscillator Select Internal precision oscillator functions as system clock at 5.6 MHz
	01	Reserved
	10	Crystal oscillator or external clock driver functions as system clock
	11	Watchdog Timer oscillator functions as system clock

Hex Address: F87

Oscillator Divide Register (OSCDIV)

BITS	7	6	5	4	3	2	1	0
FIELD	DIV							
RESET	00H*							
R/W	R/W							
ADDR	F87H							

* The reset value is 08H if the option bit `LPDEN` is 0.

Bit Position	Value (H)	Description
[7:0] DIV	00H to FFH	Oscillator Divide 00H - divider is disabled, all other entries are the divide value for scaling the system clock.

Trim Control

Hex Addresses: F88–F8F

Reserved

Comparator and Op Amp

Hex Address: F90

Comparator and Op Amp Control Register (CMPOPC)

BITS	7	6	5	4	3	2	1	0
FIELD	OPEN	Reserved		CPSEL	CMPIRQ	CMPIV	CMPOUT	CMPEN
RESET	0	00		0	0	0	X	0
R/W	R/W	R/W		R/W	R/W	R/W	R	R/W
ADDR	F90H							

Bit Position	Value (H)	Description
[7] OPEN	0	Operational Amplifier Disable Operational amplifier is disabled.
	1	Operational amplifier is enabled.
[6:5] Reserved		Must be 0.
[4] CPSEL	0	Comparator Input Select Comparator input is PA1
	1	Comparator input is PB4
[3] CMPIRQ	0	Comparator Interrupt Edge Select Interrupt Request on Comparator Rising Edge
	1	Interrupt Request on Comparator Falling Edge
[2] CMPIV	0	PWM Fault Comparator Polarity PWM Fault is active when CP- > CP+
	1	PWM Fault is active when CP+ > CP-
[1] CMPOUT	0	Comparator Output Value Comparator output is logical 0.
	1	Comparator output is logical 1.
[0] CMPEN	0	Comparator Enable Comparator is disabled.
	1	Comparator is enabled.

Hex Addresses: F91–FBF

Reserved

Interrupt Controller

Hex Address: FC0

Interrupt Request 0 Register (IRQ0)

BITS	7	6	5	4	3	2	1	0
FIELD	PWMI	FLTI	ADCI	CMPI	TOI	U0RXI	U0TXI	SPII
RESET	0	0	0	0	0	0	0	0
R/W	R/W	R/W	R/W	R/W	R/W	R/W	R/W	R/W
ADDR	FC0H							

Bit Position	Value (H)	Description
[7] PWMI	0	PWM Timer Interrupt Request No interrupt request is pending for the PWM.
	1	An interrupt request from the PWM is awaiting service.
[6] FLTI	0	Fault Interrupt Request. The fault interrupt is generated in the PWM module and originates from the Fault0 pin, Fault1 pin or the Comparator output. An interrupt enable for each of these sources exists in the PWM module. No Fault interrupt request is pending.
	1	A Fault interrupt request is awaiting service.
[5] ADCI	0	ADC Interrupt Request No interrupt request is pending for the Analog to Digital Converter.
	1	An interrupt request from the Analog to Digital Converter is awaiting service.
[4] CMPI	0	Comparator Interrupt Request No interrupt request is pending for the Comparators.
	1	An interrupt request from the Comparators is awaiting service.
[3] TOI	0	Timer 0 Interrupt Request No interrupt request is pending for Timer 0.
	1	An interrupt request from Timer 0 is awaiting service.

Bit Position	Value (H)	Description
[2] U0RXI	0	UART 0 Receiver Interrupt Request No interrupt request is pending for the UART 0 receiver.
	1	An interrupt request from the UART 0 receiver is awaiting service.
[1] U0TXI	0	UART 0 Transmitter Interrupt Request No interrupt request is pending for the UART 0 transmitter.
	1	An interrupt request from the UART 0 transmitter is awaiting service.
[0] SPII	0	SPI Interrupt Request No interrupt request is pending for the SPI.
	1	An interrupt request from the SPI is awaiting service.

Hex Address: FC1

IRQ0 Enable High Bit Register (IRQ0ENH)

BITS	7	6	5	4	3	2	1	0
FIELD	PWMENH	FLTENH	ADCENH	CMPENH	T0ENH	U0RENH	U0TENH	SPIENH
RESET	0	0	0	0	0	0	0	0
R/W	R/W	R/W	R/W	R/W	R/W	R/W	R/W	R/W
ADDR	FC1H							

Hex Address: FC2

IRQ0 Enable Low Bit Register (IRQ0ENL)

BITS	7	6	5	4	3	2	1	0
FIELD	PWMENL	FLTENL	ADCENL	CMPENL	T0ENL	U0RENL	U0TENL	SPIENL
RESET	0	0	0	0	0	0	0	0
R/W	R/W	R/W	R/W	R/W	R/W	R/W	R/W	R/W
ADDR	FC2H							

Hex Address: FC3

Interrupt Request 1 Register (IRQ1)

BITS	7	6	5	4	3	2	1	0
FIELD	I2CI	Reserved	PC0I	PBI	PA73I	PA62I	PA51I	PA40I
RESET	0	0	0	0	0	0	0	0
R/W	R/W	R	R/W	R/W	R/W	R/W	R/W	R/W
ADDR	FC3H							

Bit Position	Value (H)	Description
[7] I2CI	0	I2C Interrupt Request No interrupt request is pending for I2C.
	1	An interrupt request from I2C is awaiting service.
[5] PC0I	0	PC0 Interrupt Request — Logic in the Port C GPIO module selects either the rising or falling edge. No interrupt request is pending for PC0.
	1	An interrupt request from PC0 is awaiting service.
[4] PBI	0	PB3 – PB0 Interrupt Request No interrupt request is pending for any PB3 – PB0.
	1	An interrupt request from PB3 – PB0 is awaiting service.
[3] PA73I	0	PA7 or PA3 Interrupt Request — Logic in the Port A GPIO module selects either PA7 or PA3 and either rising or falling edge. No interrupt request is pending for PA7 or PA3
	1	An interrupt request from PA7 or PA3 is awaiting service.
[2] PA62I	0	PA6 or PA2 Interrupt Request — Logic in the Port A GPIO module selects either PA6 or PA2 and either rising or falling edge. No interrupt request is pending for PA6 or PA2
	1	An interrupt request from PA6 or PA2 is awaiting service.
[1] PA51I	0	PA5 or PA1 Interrupt Request — Logic in the Port A GPIO module selects either PA5 or PA1 and either rising or falling edge. No interrupt request is pending for PA5 or PA1
	1	An interrupt request from PA5 or PA1 is awaiting service.

Bit Position	Value (H)	Description
[0] PA40I		PA4 or PA0 Interrupt Request — Logic in the Port A GPIO module selects either PA4 or PA0 and either rising or falling edge.
	0	No interrupt request is pending for PA4 or PA0
	1	An interrupt request from PA4 or PA0 is awaiting service.

Hex Address: FC4

IRQ1 Enable High Bit Register (IRQ1ENH)

BITS	7	6	5	4	3	2	1	0
FIELD	I2CENH	Reserved	PC0ENH	PBENH	PA73ENH	PA62ENH	PA51ENH	PA40ENH
RESET	0	0	0	0	0	0	0	0
R/W	R/W	R	R/W	R/W	R/W	R/W	R/W	R/W
ADDR	FC4H							

Bit Position	Name	Description
[7]	I2CENH	I2C Interrupt Request Enable High Bit
[5]	PC0ENH	Port C0 Interrupt Request Enable High Bit
[4]	PBENH	Port B[3:0] Interrupt Request Enable High Bit
[3]	PA73ENH	Port A73 Interrupt Request Enable High Bit
[2]	PA62ENH	Port A62 Interrupt Request Enable High Bit
[1]	PA51ENH	Port A51 Interrupt Request Enable High Bit
[0]	PA40ENH	Port A40 Interrupt Request Enable High Bit

Hex Address: FC5

IRQ1 Enable Low Bit Register (IRQ1ENL)

BITS	7	6	5	4	3	2	1	0
FIELD	I2CENL	Reserved	PC0ENL	PBENL	PA73ENL	PA62ENL	PA51ENL	PA40ENL
RESET	0	0	0	0	0	0	0	0
R/W	R/W	R	R/W	R/W	R/W	R/W	R/W	R/W
ADDR	FC5H							

Bit Position	Name	Description
[7]	I2CENL	I2C Interrupt Request Enable Low Bit
[5]	PC0ENL	Port C0 Interrupt Request Enable Low Bit
[4]	PBENL	Port B[3:0] Interrupt Request Enable Low Bit
[3]	PA73ENL	Port A73 Interrupt Request Enable Low Bit
[2]	PA62ENL	Port A62 Interrupt Request Enable Low Bit
[1]	PA51ENL	Port A51 Interrupt Request Enable Low Bit
[0]	PA40ENL	Port A40 Interrupt Request Enable Low Bit

Hex Addresses: FC9–FCE

Reserved

Hex Address: FCF

Interrupt Control Register (IRQCTL)

BITS	7	6	5	4	3	2	1	0
FIELD	IRQE	Reserved						
RESET	0	0	0	0	0	0	0	0
R/W	R/W	R	R	R	R	R	R	R
ADDR	FCFH							

GPIO Port A

Hex Address: FD0

Port A–C GPIO Address Registers (PxADDR)

BITS	7	6	5	4	3	2	1	0
FIELD	PADDR[7:0]							
RESET	00H							
R/W	R/W							
ADDR	FD0H, FD4H, FD8H							

Hex Address: FD1

Port A–C Control Registers (PxCTL)

BITS	7	6	5	4	3	2	1	0
FIELD	PCTL							
RESET	00H							
R/W	R/W							
ADDR	FD1H, FD5H, FD9H							

Hex Address: FD2

Port A-C Input Data Registers (PxIN)

BITS	7	6	5	4	3	2	1	0
FIELD	PIN7	PIN6	PIN5	PIN4	PIN3	PIN2	PIN1	PIN0
RESET	X	X	X	X	X	X	X	X
R/W	R	R	R	R	R	R	R	R
ADDR	FD2H, FD6H, FDAH							

Bit Position	Value (H)	Description
[7:0] PIN	0	Port Input Data x Input data is a logical 0 (Low).
	1	Input data is a logical 1 (High).

Hex Address: FD3

Port A-C Output Data Register (PxOUT)

BITS	7	6	5	4	3	2	1	0
FIELD	POUT7	POUT6	POUT5	POUT4	POUT3	POUT2	POUT1	POUT0
RESET	0	0	0	0	0	0	0	0
R/W	R/W	R/W	R/W	R/W	R/W	R/W	R/W	R/W
ADDR	FD3H, FD7H, FDBH							

Bit Position	Value (H)	Description
[7:0] POUT	0	Port Output Data x Drive is a logical 0 (Low).
	1	Drive is a logical 1 (High). High value is not driven if the drain has been disabled by setting the corresponding Port Output Control register bit to 1.

GPIO Port B

Hex Address: FD4

Port A-C GPIO Address Registers (PxADDR)

BITS	7	6	5	4	3	2	1	0
FIELD	PADDR[7:0]							
RESET	00H							
R/W	R/W							
ADDR	FD0H, FD4H, FD8H							

Hex Address: FD5

Port A–C Control Registers (PxCTL)

BITS	7	6	5	4	3	2	1	0
FIELD	PCTL							
RESET	00H							
R/W	R/W							
ADDR	FD1H, FD5H, FD9H							

Hex Address: FD6

Port A-C Input Data Registers (PxIN)

BITS	7	6	5	4	3	2	1	0
FIELD	PIN7	PIN6	PIN5	PIN4	PIN3	PIN2	PIN1	PIN0
RESET	X	X	X	X	X	X	X	X
R/W	R	R	R	R	R	R	R	R
ADDR	FD2H, FD6H, FDAH							

Bit Position	Value (H)	Description
[7:0] PIN	0	Port Input Data x Input data is a logical 0 (Low).
	1	Input data is a logical 1 (High).

Hex Address: FD7

Port A-C Output Data Register (PxOUT)

BITS	7	6	5	4	3	2	1	0
FIELD	POUT7	POUT6	POUT5	POUT4	POUT3	POUT2	POUT1	POUT0
RESET	0	0	0	0	0	0	0	0
R/W	R/W	R/W	R/W	R/W	R/W	R/W	R/W	R/W
ADDR	FD3H, FD7H, FDBH							

Bit Position	Value (H)	Description
[7:0] POUT	0	Port Output Data x Drive is a logical 0 (Low).
	1	Drive is a logical 1 (High). High value is not driven if the drain has been disabled by setting the corresponding Port Output Control register bit to 1.

GPIO Port C

Hex Address: FD8

Port A–C GPIO Address Registers (PxADDR)

BITS	7	6	5	4	3	2	1	0
FIELD	PADDR[7:0]							
RESET	00H							
R/W	R/W							
ADDR	FD0H, FD4H, FD8H							

Hex Address: FD9

Port A–C Control Registers (PxCTL)

BITS	7	6	5	4	3	2	1	0
FIELD	PCTL							
RESET	00H							
R/W	R/W							
ADDR	FD1H, FD5H, FD9H							

Hex Address: FDA

Port A-C Input Data Registers (PxIN)

BITS	7	6	5	4	3	2	1	0
FIELD	PIN7	PIN6	PIN5	PIN4	PIN3	PIN2	PIN1	PIN0
RESET	X	X	X	X	X	X	X	X
R/W	R	R	R	R	R	R	R	R
ADDR	FD2H, FD6H, FDAH							

Bit Position	Value (H)	Description
--------------	-----------	-------------

[7:0] PIN	0	Port Input Data x Input data is a logical 0 (Low).
	1	Input data is a logical 1 (High).

Hex Address: FDB

Port A-C Output Data Register (PxOUT)

BITS	7	6	5	4	3	2	1	0
FIELD	POUT7	POUT6	POUT5	POUT4	POUT3	POUT2	POUT1	POUT0
RESET	0	0	0	0	0	0	0	0
R/W	R/W	R/W	R/W	R/W	R/W	R/W	R/W	R/W
ADDR	FD3H, FD7H, FDBH							

Bit Position	Value (H)	Description
--------------	-----------	-------------

[7:0] POUT	0	Port Output Data x Drive is a logical 0 (Low).
	1	Drive is a logical 1 (High). High value is not driven if the drain has been disabled by setting the corresponding Port Output Control register bit to 1.

Reset and Watchdog Timer

Hex Address: FF0

Reset Status and Control Register (RSTSTAT)

BITS	7	6	5	4	3	2	1	0
FIELD	POR	STOP	WDT	EXT	FLT	Reserved		FLTSEL
RESET	See Table 10 .							0
R/W	R	R	R	R	R	R		R/W
ADDR	FF0H							

Hex Address: FF1

Reserved

Hex Address: FF2

Watchdog Timer Reload High Byte Register (WDTH)

BITS	7	6	5	4	3	2	1	0
FIELD	WDTH							
RESET	04H							
R/W	R/W*							
ADDR	FF2H							

R/W* - Read returns the current WDT count value. Write sets the desired Reload Value.

Hex Address: FF3

Watchdog Timer Reload Low Byte Register (WDTL)

BITS	7	6	5	4	3	2	1	0
FIELD	WDTL							
RESET	00H							
R/W	R/W*							
ADDR	FF3H							

R/W* - Read returns the current WDT count value. Write sets the desired Reload Value.

Hex Addresses: FF4–FF5

Reserved

Hex Address: FF6

Trim Bit Address Register (TRMADR)

BITS	7	6	5	4	3	2	1	0
FIELD	TRMADR							
RESET	00H							
R/W	R/W							
ADDR	FF6H							

Bit Position Value (H) Description

[7:0] 00 - 1FH Trim Bit Address Register
TRMADR

Hex Address: FF7

Trim Bit Data Register (TRMDR)

BITS	7	6	5	4	3	2	1	0
FIELD	TRMDR							
RESET	00H							
R/W	R/W							
ADDR	FF7H							

Bit Position Value (H) Description

[7:0] 00 - FFH Trim Bit Data Register
TRMDR

Flash Memory Controller

Hex Address: FF8

Flash Control Register (FCTL)

BITS	7	6	5	4	3	2	1	0
FIELD	FCMD							
RESET	00H							
R/W	W							
ADDR	FF8H							

Bit Position	Value	Description
--------------	-------	-------------

[7:0]		Flash Command
FCMD	73H	First unlock command.
	8CH	Second unlock command.
	95H	Page erase command.
	63H	Mass erase command.
	5EH	Flash Sector Protect register select.
		All other commands, or any command out of sequence, locks the Flash Controller.

Hex Address: FF9

Flash Status Register (FSTAT)

BITS	7	6	5	4	3	2	1	0
FIELD	Reserved		FSTAT					
RESET	00B		00_0000B					
R/W	R		R					
ADDR	FF8H							

Bit Position	Value	Description
[7:6] Reserved		Must be 00.
[5:0] FSTAT		Flash Controller Status
	00_0000	Flash Controller locked.
	00_0001	First unlock command received.
	00_0010	Second unlock command received.
	00_0011	Flash Controller unlocked.
	00_0100	Flash Sector Protect register selected.
	00_1xxx	Program operation in progress.
	01_0xxx	Page erase operation in progress.
	10_0xxx	Mass erase operation in progress.

Flash Sector Protect Register (FPROT)

BITS	7	6	5	4	3	2	1	0
FIELD	SECT7	SECT6	SECT5	SECT4	SECT3	SECT2	SECT1	SECT0
RESET	0	0	0	0	0	0	0	0
R/W	R/W1	R/W1	R/W1	R/W1	R/W1	R/W1	R/W1	R/W1
ADDR	FF9H							
R/W1 = Register is accessible for Read operations. Register can be written to 1 only (through user code).								

Bit Position	Value	Description
[7:0]] SECT n	0	Sector Protect Sector n can be programmed or erased from user code.
	1	Sector n is protected and cannot be programmed or erased from user code.

Hex Address: FFA

Flash Frequency High Byte Register (FFREQH)

BITS	7	6	5	4	3	2	1	0
FIELD	FFREQH							
RESET	00H							
R/W	R/W							
ADDR	FFAH							

Hex Address: FFB

Flash Frequency Low Byte Register (FFREQL)

BITS	7	6	5	4	3	2	1	0
FIELD	FFREQL							
RESET	00H							
R/W	R/W							
ADDR	FFBH							

eZ8 CPU

Refer to the *eZ8 CPU User Manual (UM0128)* available at www.zilog.com.

Opcode Maps

The following two figures provide information about each of the eZ8 CPU instructions.

		Lower Nibble (Hex)															
		0	1	2	3	4	5	6	7	8	9	A	B	C	D	E	F
0	1.1 BRK	2.2 SRP IM	2.3 ADD r1,r2	2.4 ADD r1,lr2	3.3 ADD R2,R1	3.4 ADD IR2,R1	3.3 ADD R1,IM	3.4 ADD IR1,IM	4.3 ADDX ER2,ER1	4.3 ADDX IM,ER1	2.3 DJNZ r1,X	2.2 JR cc,X	2.2 LD r1,IM	3.2 JP cc,DA	1.2 INC r1	1.2 NOP	
1	2.2 RLC R1	2.3 RLC IR1	2.3 ADC r1,r2	2.4 ADC r1,lr2	3.3 ADC R2,R1	3.4 ADC IR2,R1	3.3 ADC R1,IM	3.4 ADC IR1,IM	4.3 ADCX ER2,ER1	4.3 ADCX IM,ER1						See 2nd Op Code Map	
2	2.2 INC R1	2.3 INC IR1	2.3 SUB r1,r2	2.4 SUB r1,lr2	3.3 SUB R2,R1	3.4 SUB IR2,R1	3.3 SUB R1,IM	3.4 SUB IR1,IM	4.3 SUBX ER2,ER1	4.3 SUBX IM,ER1						1.1 ATM	
3	2.2 DEC R1	2.3 DEC IR1	2.3 SBC r1,r2	2.4 SBC r1,lr2	3.3 SBC R2,R1	3.4 SBC IR2,R1	3.3 SBC R1,IM	3.4 SBC IR1,IM	4.3 SBCX ER2,ER1	4.3 SBCX IM,ER1							
4	2.2 DA R1	2.3 DA IR1	2.3 OR r1,r2	2.4 OR r1,lr2	3.3 OR R2,R1	3.4 OR IR2,R1	3.3 OR R1,IM	3.4 OR IR1,IM	4.3 ORX ER2,ER1	4.3 ORX IM,ER1							
5	2.2 POP R1	2.3 POP IR1	2.3 AND r1,r2	2.4 AND r1,lr2	3.3 AND R2,R1	3.4 AND IR2,R1	3.3 AND R1,IM	3.4 AND IR1,IM	4.3 ANDX ER2,ER1	4.3 ANDX IM,ER1						1.2 WDT	
6	2.2 COM R1	2.3 COM IR1	2.3 TCM r1,r2	2.4 TCM r1,lr2	3.3 TCM R2,R1	3.4 TCM IR2,R1	3.3 TCM R1,IM	3.4 TCM IR1,IM	4.3 TCMX ER2,ER1	4.3 TCMX IM,ER1						1.2 STOP	
7	2.2 PUSH R2	2.3 PUSH IR2	2.3 TM r1,r2	2.4 TM r1,lr2	3.3 TM R2,R1	3.4 TM IR2,R1	3.3 TM R1,IM	3.4 TM IR1,IM	4.3 TMX ER2,ER1	4.3 TMX IM,ER1						1.2 HALT	
8	2.5 DECW RR1	2.6 DECW IRR1	2.5 LDE r1,lr2	2.8 LDEI lr1,lr2	3.2 LDX r1,ER2	3.3 LDX lr1,ER2	3.4 LDX IRR2,R1	3.5 LDX IRR2,IR1	3.4 LDX³ r1,rr2,X	3.4 LDX³ rr1,r2,X						1.2 DI	
9	2.2 RL R1	2.3 RL IR1	2.5 LDE r2,lr1	2.8 LDEI lr2,lr1	3.2 LDX r2,ER1	3.3 LDX lr2,ER1	3.4 LDX R2,IRR1	3.5 LDX IRR2,IRR1	3.3 LEA r1,r2,X	3.5 LEA³ rr1,rr2,X						1.2 EI	
A	2.5 INCW RR1	2.6 INCW IRR1	2.3 CP r1,r2	2.4 CP r1,lr2	3.3 CP R2,R1	3.4 CP IR2,R1	3.3 CP R1,IM	3.4 CP IR1,IM	4.3 CPX ER2,ER1	4.3 CPX IM,ER1						1.4 RET	
B	2.2 CLR R1	2.3 CLR IR1	2.3 XOR r1,r2	2.4 XOR r1,lr2	3.3 XOR R2,R1	3.4 XOR IR2,R1	3.3 XOR R1,IM	3.4 XOR IR1,IM	4.3 XORX ER2,ER1	4.3 XORX IM,ER1						1.5 IRET	
C	2.2 RRC R1	2.3 RRC IR1	2.5 LDC r1,lr2	2.8 LDCI lr1,lr2	2.3 JP² IRR1	2.8 LDC lr1,lr2		3.4 LD r1,r2,X	3.3 PUSHX³ ER2							1.2 RCF	
D	2.2 SRA R1	2.3 SRA IR1	2.5 LDC r2,lr1	2.8 LDCI lr2,lr1	2.6 CALL² IRR1	2.2 BSWAP R1	3.3 CALL DA	3.4 LD r2,r1,X	3.3 POPX³ ER1							1.2 SCF	
E	2.2 RR R1	2.3 RR IR1	2.2 BIT p,b,r1	2.3 LD r1,lr2	3.2 LD R2,R1	3.3 LD IR2,R1	3.3 LD R1,IM	3.4 LD IR1,IM	4.2 LDX ER2,ER1	4.2 LDX IM,ER1						1.2 CCF	
F	2.2 SWAP R1	2.6 SWAP IR1	2.6 TRAP Vector	2.3 LD lr1,r2	2.9 MULT RR1	3.3 LD R2,IR1	3.3 BTJ p,b,r1,X	3.4 BTJ p,b,lr1,X									

First Opcode Map

		Lower Nibble (Hex)															
		0	1	2	3	4	5	6	7	8	9	A	B	C	D	E	F
Upper Nibble (Hex)	0																
	1																
	2																
	3																
	4																
	5																
	6																
	7		3.2 PUSH IM														
	8																
	9																
	A			3.3 CPC r1,r2	3.4 CPC r1,lr2	4.3 CPC R2,R1	4.4 CPC IR2,R1	4.3 CPC R1,IM	4.4 CPC IR1,IM	5.3 CPCX ER2,ER1	5.3 CPCX IM,ER1						
	B																
	C		3.2 SRL R1	3.3 SRL IR1													
	D																
	E										4.2 LDWX ER2,ER1						
	F																

Second Opcode Map after 1Fh



Index

Symbols

278
% 278
@ 278

Numerics

10-bit ADC 4
32-pin QFN and LQFP packages 7

A

absolute maximum ratings 255
AC characteristics 261
ADC 280

- block diagram 198
- electrical characteristics and timing 265
- overview 197

ADC Channel Register 1 (ADCCTL) 201, 335
ADC Data High Byte Register (ADCDH) 202, 203, 206, 207, 309, 310, 336, 337
ADC Data Low Bit Register (ADC DL) 203, 204, 205, 337, 338, 339
ADC Timer Capture Register 206
ADCX 280
ADD 280
add - extended addressing 280
add with carry 280
add with carry—extended addressing 280
additional symbols 278
address space 11
ADDX 280
analog block/PWM signal synchronization 200
analog signals 9
analog-to-digital converter

- overview 197

AND 283
ANDX 283
architecture

- voltage measurements 197

arithmetic instructions 280
assembly language programming 275
assembly language syntax 276
ATM 283
atomic 283

B

B 278
b 277
baud rate generator, UART 125
BCLR 281
binary number suffix 278
BIT 281
bit 277

- clear 281
- manipulation instructions 281
- set 281
- set or clear 281
- swap 281
- test and jump 283
- test and jump if non-zero 283
- test and jump if zero 283

bit jump and test if non-zero 283
bit swap 284
block diagram 2
block transfer instructions 281
BRK 283
BSET 281
BSWAP 281, 284
BTJ 283
BTJNZ 283
BTJZ 283

C

calibration and compensation, motor control measurements 201
CALL procedure 283
cc 277

CCF 282
characteristics
 pin 10
characteristics, electrical 255
clear 282
clock phase (SPI) 150
CLR 282
COM 283
comparator
 definition 193
 noninverting/inverting input 193
 operation 193
compare - extended addressing 280
compare with carry 280
compare with carry - extended addressing 280
complement 283
complement carry flag 281, 282
condition code 277
control register definition, UART 128
control register, I2C 184
CP 280
CPC 280
CPCX 280
CPU and peripheral overview 3
CPU control instructions 282
CPX 280
current measurement
 architecture 197
 operation 198

D

DA 277, 280
data register, I2C 182
DC characteristics 256
debugger, on-chip 239
DEC 280
decimal adjust 280
decrement 280
decrement and jump non-zero 283
decrement word 280
DECW 280
destination operand 278
device, port availability 33

DI 282
direct address 277
disable interrupts 282
DJNZ 283
DMA
 controller 4
dst 278

E

EI 282
electrical characteristics 255
 ADC 265
 GPIO input data sample timing 269
 watch-dog timer 265
electrical noise 197
enable interrupt 282
ER 277
extended addressing register 277
external pin reset 24
external RC oscillator 264
eZ8 CPU features 3
eZ8 CPU instruction classes 280
eZ8 CPU instruction notation 277
eZ8 CPU instruction set 275
eZ8 CPU instruction summary 284

F

FCTL register 215, 225, 354, 355
first opcode map 297, 358
FLAGS 278
flags register 278
flash
 controller 4
 option bit address space 222
 option bit configuration - reset 222
 program memory address 0000H 222
 program memory address 0001H 223
flash memory
 arrangement 210
 byte programming 213
 code protection 211
 configurations 209

controller bypass 214
flash control register 215, 225, 354, 355
flash status register 216
frequency high and low byte registers 218
mass erase 214
operation 211
operation timing 211
page erase 214
page select register 216
FPS register 216
FSTAT register 216

G

general-purpose I/O 33
GPIO 4, 33
 alternate functions 34
 architecture 33
 control register definitions 38
 input data sample timing 269
 interrupts 37
 port A-C pull-up enable sub-registers 43
 port A-H address registers 39
 port A-H alternate function sub-registers 41, 46
 port A-H control registers 40
 port A-H data direction sub-registers 40
 port A-H high drive enable sub-registers 43
 port A-H input data registers 46
 port A-H output control sub-registers 42
 port A-H output data registers 47
 port A-H STOP mode recovery sub-registers 43
 port availability by device 33
 port input timing 269
 port output timing 270

H

H 278
HALT 282
halt mode 29, 282
hexadecimal number prefix/suffix 278

I

I2C 4
 10-bit address read transaction 173
 10-bit address transaction 170
 10-bit addressed slave data transfer format 170, 178
 7-bit address transaction 167, 175
 7-bit address, reading a transaction 172
 7-bit addressed slave data transfer format 169, 177
 7-bit receive data transfer format 173, 179, 180
 baud high and low byte registers 185, 186, 191
 C status register 183, 187, 330, 332
 controller 161
 interrupts 165
 operation 164
 SDA and SCL signals 164
 stop and start conditions 167
I2CBRH register 186, 188, 190, 191, 331, 332
I2CBRL register 186, 331
I2CCTL register 184, 331
I2CDATA register 182, 330
I2CSTAT register 183, 187, 330, 332
IM 277
immediate data 277
immediate operand prefix 278
INC 280
increment 280
increment word 280
INCW 280
indexed 278
indirect address prefix 278
indirect register 277
indirect register pair 277
indirect working register 277
indirect working register pair 277
infrared encoder/decoder (IrDA) 143
instruction set, ez8 CPU 275
instructions
 ADC 280
 ADCX 280
 ADD 280

ADDX 280
 AND 283
 ANDX 283
 arithmetic 280
 ATM 283
 BCLR 281
 BIT 281
 bit manipulation 281
 block transfer 281
 BRK 283
 BSET 281
 BSWAP 281, 284
 BTJ 283
 BTJNZ 283
 BTJZ 283
 CALL 283
 CCF 281, 282
 CLR 282
 COM 283
 CP 280
 CPC 280
 CPCX 280
 CPU control 282
 CPX 280
 DA 280
 DEC 280
 DECW 280
 DI 282
 DJNZ 283
 EI 282
 HALT 282
 INC 280
 INCW 280
 IRET 283
 JP 283
 LD 282
 LDC 282
 LDCI 281, 282
 LDE 282
 LDEI 281
 LDWX 282
 LDX 282
 LEA 282
 load 282
 logical 283
 MULT 281
 NOP 282
 OR 283
 ORX 283
 POP 282
 POPX 282
 program control 283
 PUSH 282
 PUSHX 282
 RCF 281, 282
 RET 283
 RL 284
 RLC 284
 rotate and shift 284
 RR 284
 RRC 284
 SBC 281
 SCF 281, 282
 SRA 284
 SRL 284
 SRP 282
 STOP 282
 SUB 281
 SUBX 281
 SWAP 284
 TCM 281
 TCMX 281
 TM 281
 TMX 281
 TRAP 283
 watch-dog timer refresh 282
 XOR 283
 XORX 283
 instructions, eZ8 classes of 280
 interrupt control register 58
 interrupt controller 4, 49
 architecture 49
 interrupt assertion types 52
 interrupt vectors and priority 52
 register definitions 53
 software interrupt assertion 53
 interrupt edge select register 45
 Interrupt Port Select Register 45

interrupt request 0 register 53
interrupt request 1 register 54
interrupt return 283
interrupt vector listing 49
interrupts
 SPI 154
 UART 122
introduction 1
IR 277
Ir 277
IrDA
 architecture 126, 143
 block diagram 126, 143
 control register definitions 146
 operation 126, 143
 receiving data 145
 transmitting data 144
IRET 283
IRQ0 enable high and low bit registers 56
IRQ1 enable high and low bit registers 57
IRR 277
Irr 277

J
JP 283
jump, conditional, relative, and relative conditional 283

L
LD 282
LDC 282
LDCI 281, 282
LDE 282
LDEI 281, 282
LDWX 282
LDX 282
LEA 282
load 282
load constant 281
load constant to/from program memory 282
load constant with auto-increment addresses 282
load effective address 282

load external data 282
load external data to/from data memory and auto-increment addresses 281
load external to/from data memory and auto-increment addresses 282
load instructions 282
load using extended addressing 282
load word using extended addressing 282
logical AND 283
logical AND/extended addressing 283
logical exclusive OR 283
logical exclusive OR/extended addressing 283
logical instructions 283
logical OR 283
logical OR/extended addressing 283
low power modes 29

M

master interrupt enable 51
master-in, slave-out and-in 149
memory
 program 12
MISO 149
MOSI 149
motor control measurements
 calibration and compensation 201
 interrupts 200
 overview 197
MULT 281
multiply 281
multiprocessor mode, UART 116

N

noise, electrical 197
NOP (no operation) 282
notation
 b 277
 cc 277
 DA 277
 ER 277
 IM 277
 IR 277

- Ir 277
- IRR 277
- Irr 277
- p 277
- R 277
- r 277
- RA 277
- RR 277
- rr 277
- vector 278
- X 278
- notational shorthand 277

- O**
- OCD
 - architecture 239
 - auto-baud detector/generator 242
 - baud rate limits 242
 - block diagram 239
 - breakpoints 243
 - commands 245
 - data format 241
 - DBG pin to RS-232 Interface 240
 - debug mode 240
 - debugger break 283
 - interface 239
 - serial errors 242
 - status register 252
 - timing 271
- OCD commands
 - execute instruction (12H) 250
 - read data memory (0DH) 249
 - read OCD control register (05H) 247
 - read OCD revision (00H) 246
 - read program counter (07H) 247
 - read program memory (0BH) 248
 - read program memory CRC (0EH) 249
 - read register (09H) 248
 - read runtime counter (03H) 247
 - step instruction (10H) 250
 - stuff instruction (11H) 250
 - write data memory (0CH) 249
 - write OCD control register (04H) 247
 - write program counter (06H) 247
 - write program memory (0AH) 248
 - write register (08H) 248
- on-chip debugger 4
- on-chip debugger (OCD) 239
- on-chip debugger signals 9
- opcode map
 - abbreviations 295
 - cell description 295
 - first 297, 358
 - second after 1FH 298, 359
- operation 200
 - current measurement 198
 - voltage measurement timing diagram 199, 200
- operational amplifier
 - operation 194
 - overview 193
- Operational Description 65, 89, 109, 229, 237
- OR 283
- ordering information 300
- ORX 283
- oscillator signals 9

- P**
- p 277
- package
 - 32-pin QFN and LQFP 7
- part number description 302
- PC 278
- peripheral AC and DC electrical characteristics 262
- PHASE=0 timing (SPI) 151
- PHASE=1 timing (SPI) 152
- pin characteristics 10
- polarity 277
- POP 282
- pop using extended addressing 282
- POPX 282
- port availability, device 33
- port input timing (GPIO) 269
- port output timing, GPIO 270
- power supply signals 10
- power-on reset (POR) 23
- program control instructions 283

program counter 278
 program memory 12
 PUSH 282
 push using extended addressing 282
 PUSHX 282
 PxADDR register 39, 348, 349, 351
 PxCTL register 40, 348, 350, 351

R

R 277
 r 277
 RA
 register address 277
 RCF 281, 282
 receive
 7-bit data transfer format (I2C) 173, 179, 180
 IrDA data 145
 receiving UART data-interrupt-driven method 114
 receiving UART data-pollled method 113
 register 158, 277, 334
 baud low and high byte (I2C) 185, 186, 191
 baud rate high and low byte (SPI) 160
 control (SPI) 155
 control, I2C 184
 data, SPI 155
 flash control (FCTL) 215, 225, 354, 355
 flash high and low byte (FFREQH and FRE-
 EQL) 218
 flash page select (FPS) 216
 flash status (FSTAT) 216
 GPIO port A-H address (PxADDR) 39, 348,
 349, 351
 GPIO port A-H alternate function sub-registers
 42, 46
 GPIO port A-H control address (PxCTL) 40,
 348, 350, 351
 GPIO port A-H data direction sub-registers 40
 I2C baud rate high (I2CBRH) 186, 188, 190,
 191, 331, 332
 I2C control (I2CCTL) 184, 331
 I2C data (I2CDATA) 182, 330
 I2C status 183, 187, 330, 332
 I2C status (I2CSTAT) 183, 187, 330, 332

I2Cbaud rate low (I2CBRL) 186, 331
 mode, SPI 158
 OCD status 252
 SPI baud rate high byte (SPIBRH) 160, 334
 SPI baud rate low byte (SPIBRL) 160, 335
 SPI control (SPICTL) 155, 333
 SPI data (SPIDATA) 155, 333
 SPI status (SPISTAT) 157, 333
 status, SPI 157
 UARTx baud rate high byte (UxBRH) 139
 UARTx baud rate low byte (UxBRL) 139, 330
 UARTx Control 0 (UxCTL0) 133, 138, 328,
 329
 UARTx control 1 (UxCTL1) 134, 136, 137,
 328
 UARTx receive data (UxRXD) 128, 327
 UARTx status 0 (UxSTAT0) 129, 130, 328
 UARTx status 1 (UxSTAT1) 131, 329
 UARTx transmit data (UxTXD) 128, 327
 watchdog timer control (WDTCTL) 231, 233,
 340, 341
 watch-dog timer reload high byte (WDTH) 64,
 353
 watch-dog timer reload low byte (WDTL) 64,
 353
 Register File
 address map 15
 register file 11
 register pair 277
 register pointer 278
 registers
 ADC channel 1 201, 335
 ADC data high byte 202, 203, 206, 207, 309,
 310, 336, 337
 ADC data low bit 203, 204, 205, 337, 338,
 339
 reset
 and STOP mode characteristics 21
 and STOP mode recovery 21
 carry flag 281
 controller 4
 RET 283
 return 283
 RL 284

RLC 284
rotate and shift instructions 284
rotate left 284
rotate left through carry 284
rotate right 284
rotate right through carry 284
RP 278
RR 277, 284
rr 277
RRC 284

S

SBC 281
SCF 281, 282
SCK 149
SDA and SCL (IrDA) signals 164
second opcode map after 1FH 298, 359
serial clock 149
serial peripheral interface (SPI) 147
set carry flag 281, 282
set register pointer 282
shift right arithmetic 284
shift right logical 284
signal descriptions 8
SIO 4
slave data transfer formats (I2C) 170, 178
slave select 150
software trap 283
source operand 278
SP 278
SPI
 architecture 147
 baud rate generator 154
 baud rate high and low byte register 160
 clock phase 150
 configured as slave 148
 control register 155
 data register 155
 error detection 153
 interrupts 154
 mode fault error 153
 mode register 158
 multi-master operation 152
 operation 149
 overrun error 153
 signals 149
 single master, multiple slave system 148
 single master, single slave system 147
 status register 157
 timing, PHASE = 0 151
 timing, PHASE=1 152
SPI mode (SPIMODE) 158, 334
SPIBRH register 160, 334
SPIBRL register 160, 335
SPICTL register 155, 333
SPIDATA register 155, 333
SPIMODE register 158, 334
SPISTAT register 157, 333
SRA 284
src 278
SRL 284
SRP 282
SS, SPI signal 149
stack pointer 278
STOP 282
STOP mode 29, 282
STOP mode recovery
 sources 25
 using a GPIO port pin transition 26
 using watch-dog timer time-out 26
SUB 281
subtract 281
subtract - extended addressing 281
subtract with carry 281
subtract with carry - extended addressing 281
SUBX 281
SWAP 284
swap nibbles 284
symbols, additional 278
system and core resets 22

T

TCM 281
TCMX 281
test complement under mask 281
test complement under mask - extended addressing

281
test under mask 281
test under mask - extended addressing 281
timer signals 8
timers 4, 89
 architecture 65, 89
 block diagram 66, 90
 capture mode 97
 compare mode 98
 continuous mode 93
 counter mode 94
 gated mode 99
 operating mode 91
 PWM mode 95
 reading the timer count values 100
 reload high and low byte registers 74, 102
timers 0-3
 control registers 104, 105
 high and low byte registers 73, 75, 100, 103
timing diagram, voltage measurement 199, 200
TM 281
TMX 281
transmit
 IrDA data 144
transmitting UART data-interrupt-driven method 112
transmitting UART data-pollled method 111
TRAP 283

U

UART 4
 architecture 109
 asynchronous data format without/with parity 111
 baud rate generator 125
 baud rates table 140, 141, 142
 control register definitions 128
 controller signals 8
 data format 110
 interrupts 122
 multiprocessor mode 116
 receiving data using interrupt-driven method 114

receiving data using the polled method 113
transmitting data using the interrupt-driven method 112
transmitting data using the polled method 111
x baud rate high and low registers 138
x control 0 and control 1 registers 133, 134
x status 0 and status 1 registers 129, 131
UxBRH register 139
UxBRL register 139, 330
UxCTL0 register 133, 138, 328, 329
UxCTL1 register 134, 136, 137, 328
UxRXD register 128, 327
UxSTAT0 register 129, 130, 328
UxSTAT1 register 131, 329
UxTXD register 128, 327

V

vector 278
voltage brown-out reset (VBR) 23
voltage measurement timing diagram 199, 200

W

watchdog timer
 approximate time-out delay 62
 approximate time-out delays 61, 229, 237
 control register 231, 232
 electrical characteristics and timing 265
 interrupt in normal operation 62
 interrupt in STOP mode 62
 operation 61, 229, 237
 refresh 62, 282
 reload unlock sequence 63
 reload upper, high and low registers 63
 reset 24
 reset in normal operation 63
 reset in STOP mode 63
 time-out response 62
WDTCTL register 231, 233, 340, 341
WDTH register 64, 353
WDTL register 64, 353
working register 277
working register pair 277

X

X 278

XOR 283

XORX 283

Z

Z8 Encore!

block diagram 2

introduction 1

Customer Support

For answers to technical questions about the product, documentation, or any other issues with Zilog's offerings, please visit Zilog's Knowledge Base at <http://www.zilog.com/kb>.

For any comments, detail technical questions, or reporting problems, please visit Zilog's Technical Support at <http://support.zilog.com>.