

## PWM Control Step-Down Switching Regulator-Converter

### ■ Features

- Low current consumption:  
In operation: 60µA max.  
Power off: 0.5µA max.
- Input voltage: 2.5V to 16V.
- Output voltage: 1.8V & Adjustable to 6V.
- Duty ratio: 0% to 100% PWM control
- Oscillation frequency: 180KHz typ.
- Soft-start function: 8ms typ.
- With a power-off function.
- Built-in internal SW P-channel MOS
- SOP-8L Package.

### ■ Applications

- On-board power supplies of battery devices for portable telephones, electronic notebooks, PDA, and other hand-held sets.
- Power supplies for audio equipment, including portable CD players and headphone stereo equipment.
- Fixed voltage power supply for cameras, video equipment and communications equipment.
- Power supplies for microcomputers.
- Conversion from four Ni-H or Ni-Cd cells or two lithium-ion cells to 3.3V/3V.
- Conversion of AC adapter input to 5V/3V.

### ■ Pin Assignments

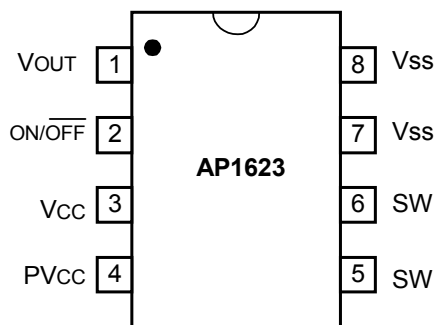

### ■ General Description

AP1623 consists of CMOS step-down switching regulator-controllers with PWM control. These devices include a reference voltage source, oscillation circuit, error amplifier, internal PMOS and etc.

AP1623 provides low-ripple power, high efficiency, and excellent transient characteristics. The PWM control circuit is able to vary the duty ratio linearly from 0 up to 100. This converter also contains an error amplifier circuit as well as a soft-start circuit that prevents overshoot at startup.

With the addition of an internal P-channel Power MOS, a coil, capacitors, and a diode connected externally, these ICs can function as step-down switching regulators. They serve as ideal power supply units for portable devices when coupled with the SOP-8L mini-package, providing such outstanding features as low current consumption. Since this converter can accommodate an input voltage of up to 16V, it is also ideal when operating via an AC adapter.

### ■ Pin Descriptions

Name	Pin	Description
V <sub>OUT</sub>	1	Output voltage monitoring pin
ON/ $\overline{\text{OFF}}$	2	Power-off pin H: Normal operation (Step-down operation) L: Step-down operation stopped (All circuits deactivated)
V <sub>CC</sub>	3	IC signal power supply pin
PV <sub>CC</sub>	4	IC power supply pin
SW	5 · 6	Switch Pin. Connect external inductor/diode here. Minimize trace area at this pin to reduce EMI.
V <sub>SS</sub>	7 · 8	GND Pin

## PWM Control Step-Down Switching Regulator-Converter

### ■ Ordering Information

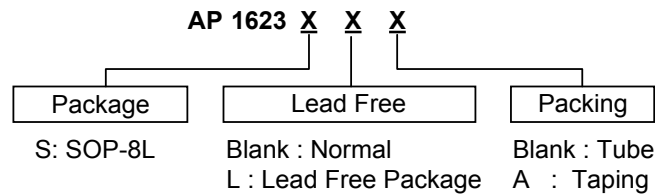

### ■ Block Diagram

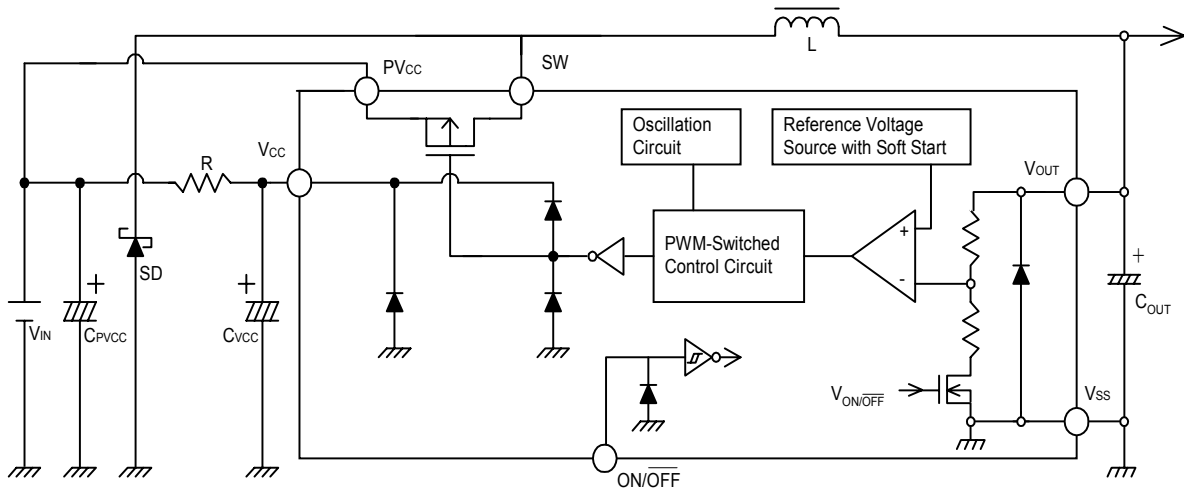

### ■ Absolute Maximum Ratings

Symbol	Parameter	Rating	Unit
$V_{CC}^{*1}$	$V_{CC}$ pin voltage	$V_{SS} - 0.3$ to $V_{SS} + 18$	V
$PV_{CC}$	$PV_{CC}$ pin voltage	$V_{SS} - 0.3$ to $V_{SS} + 18$	V
$V_{OUT}$	$V_{OUT}$ pin voltage	$V_{SS} - 0.3$ to $V_{SS} + 18$	V
$V_{ON/OFF}^{*1}$	ON/OFF pin voltage	$V_{SS} - 0.3$ to $V_{SS} + 18$	V
$V_{SW}$	Switch pin voltage	$V_{SS} - 0.3$ to $V_{IN} + 0.3$	V
$P_D$	Power dissipation	800	mW
$T_{OPR}$	Operating temperature range	-20 to +85	°C
$T_{STG}$	Storage temperature range	-20 to +125	°C

Caution: The absolute maximum ratings are rated values exceeding which the product could suffer physical damage. These values must therefore not be exceeded under any conditions.

## PWM Control Step-Down Switching Regulator-Controllers

### ■ Electrical Characteristics ( $V_{IN} = 5V$ , $T_a = 25^\circ C$ , unless otherwise specified)

Symbol	Parameter	Conditions	Min.	Typ.	Max.	Unit	
$V_{OUT(E)}$	Output voltage *1	-	$V_{OUT(S)} \times 0.976$	$V_{OUT(S)}$	$V_{OUT(S)} \times 1.024$	V	
$V_{IN}$	Input voltage	AP1623 Series	2.5	--	16	V	
$I_{SW}$	Switch Current	Duty = 50%	3	--	--	A	
$I_{SS1}$	Current consumption 1	$V_{OUT} = V_{OUT(S)} \times 1.2$	--	35	60	$\mu A$	
$I_{SSS}$	Current consumption during power off	$V_{ON/OFF} = 0V$	--	--	0.5	$\mu A$	
$\Delta V_{OUT1}$	Line regulation	$V_{IN} = V_{OUT(S)} \times 1.2$ to $\times 1.4$ *2	--	30	60	mV	
$\Delta V_{OUT2}$	Load regulation	Load current = $10\mu A$ to $I_{OUT}$ (See below) $\times 1.25$	--	30	60	mV	
$\frac{\Delta V_{OUT}}{\Delta T_a}$	Output voltage temperature coefficient	$T_a = -40^\circ C$ to $85^\circ C$	--	$\pm V_{OUT(S)} \times 5E-5$	--	$V/^\circ C$	
$f_{OSC}$	Oscillation frequency	Measure waveform at SW pin	$V_{OUT(S)} \geq 2.5V$	153	180	207	KHz
			$V_{OUT(S)} \leq 2.4V$	144	180	216	
$V_{SH}$	Power-Off pin input voltage	Evaluate oscillation at SW pin	1.8	--	--	V	
$V_{SL}$		Evaluate oscillation stop at SW pin	--	--	0.3		
$I_{SH}$	Power-Off pin input leakage current	--	-0.1	--	0.1	$\mu A$	
$I_{SL}$		--	-0.1	--	0.1	$\mu A$	
$T_{SS}$	Soft-Start time	--	4.0	8.0	16.0	ms	
EFFI	Efficiency	$V_{IN} = 5V$ , $V_{OUT} = 2.5V$ $I_{OUT} = 1A$	--	93	--	%	

#### Conditions:

The recommended components are connected to the IC, unless otherwise indicated.  $V_{IN} = V_{OUT(S)} \times 1.2[V]$ ,  $I_{OUT} = 120[mA]$  ( $V_{IN} = 2.5V$ , if  $V_{OUT(S)} \leq 2.0V$ .)

#### Peripheral components:

Coil : Sumida Electric Co., Ltd. CD54 (47 $\mu H$ ).  
 Diode : Matsushita Electronics Corporation MA720 (Schottky type).  
 Capacitor : Matsushita Electronics Corporation TE (16V, 22 $\mu F$  tantalum type).

The power-off pin is connected to  $V_{IN}$ .

#### Notes:

The output voltage indicated above represents a typical output voltage set up. These specifications apply in common to AP1623, unless otherwise noted.

\*1  $V_{OUT(S)}$  Specified output voltage value.

$V_{OUT(E)}$  Actual output voltage value.

\*2  $V_{IN} = 2.5V$  to  $2.94V$ , if  $V_{OUT(S)} \leq 2.0V$ .

## PWM Control Step-Down Switching Regulator-Controllers

### ■ Typical Application Circuit

(1) Normal Application

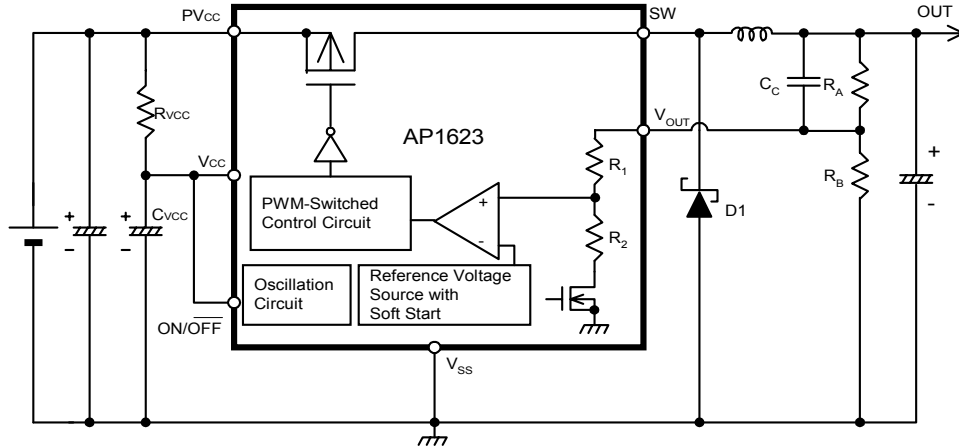

(2) Application with Short Circuit Protection

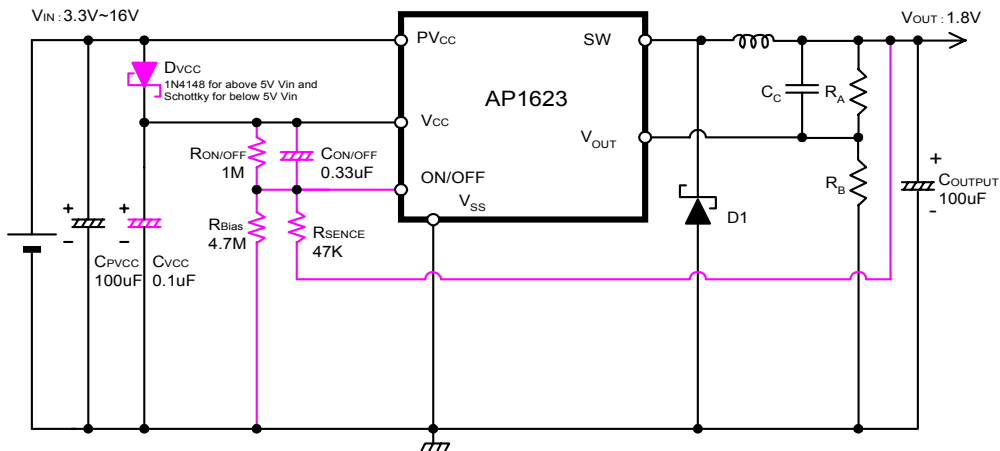

### ■ Test Circuit

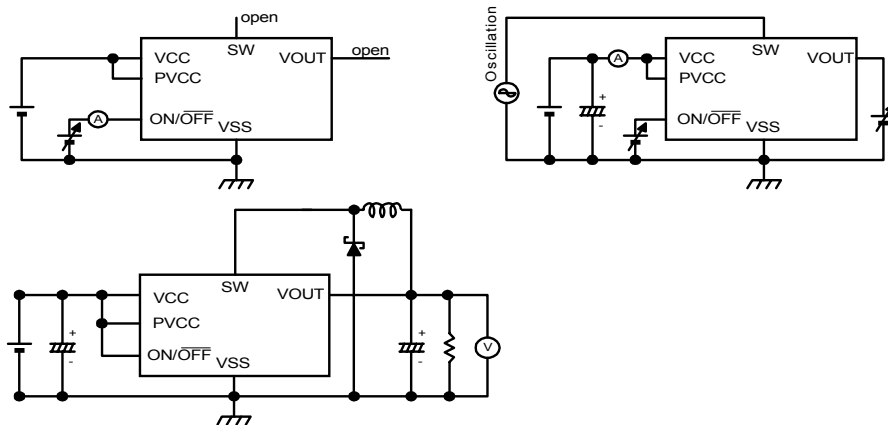

### ■ Function Description

#### PWM Control (AP1623 Series)

The AP1623 consists of DC/DC converters that employ a pulse-width modulation (PWM) system. In converters of the AP1623, the pulse width varies in a range from 0 to 100, according to the load current, and yet ripple voltage produced by the switching can easily be removed through a filter because the switching frequency remains constant. Therefore, these converters provide a low-ripple power over broad ranges of input voltage and load current.

#### External adjustment of output voltage

The AP1623 allows the user to select 3 types of the output voltage, when external resistances  $R_A$ ,  $R_B$ , and capacitor  $C_C$  are added, as illustrated in Typical Application Circuit. Moreover, a temperature gradient can be obtained by inserting a thermal-resistor or other element in series with  $R_A$  and  $R_B$ .

Therefore, the output voltage (OUT) is determined by the output voltage value  $V_{OUT}$  of the AP1623, and the ratio of the parallel resistance value of external resistance  $R_B$  and internal resistance  $R_1 + R_2$  of the IC, to external resistance  $R_A$ . The output voltage is expressed by the following equation:

$$OUT = V_{OUT} + V_{OUT} \times R_A \div (R_B // (R_1 + R_2))$$

(Note:// denotes a combined resistance in parallel.)

The voltage accuracy of the output OUT set by resistances  $R_A$  and  $R_B$  is not only affected by the IC's output voltage accuracy ( $V_{OUT} \pm 2.4\%$ ), but also by the absolute precision of external resistances  $R_A$  and  $R_B$  in use and the absolute value deviations of internal resistances  $R_1$  and  $R_2$  in the IC.

Let us designate the maximum deviations of the absolute value of external resistances  $R_A$  and  $R_B$  by  $R_{Amax}$  and  $R_{Bmax}$ , respectively, the minimum deviations by  $R_{Amin}$  and  $R_{Bmin}$ , respectively, and the maximum and minimum deviations of the absolute value of internal resistances  $R_1$  and  $R_2$  in the IC by  $(R_1 + R_2)_{max}$  and  $(R_1 + R_2)_{min}$ , respectively. Then, the minimum deviation value  $OUT_{min}$  and the maximum deviation value  $OUT_{max}$  of the output voltage OUT are expressed by the following equations:

$$OUT_{min} = V_{OUT} \times 0.976 + V_{OUT} \times 0.976 \times R_{Amin} \div (R_{Bmax} // (R_1 + R_2)_{max})$$

$$OUT_{max} = V_{OUT} \times 1.024 + V_{OUT} \times 1.024 \times R_{Amax} \div (R_{Bmin} // (R_1 + R_2)_{min})$$

The voltage accuracy of the output OUT cannot be made higher than the output voltage accuracy ( $V_{OUT} \pm 2.4\%$ ) of the IC itself, without adjusting the external resistances  $R_A$  and  $R_B$  involved. The closer

the voltage value of the output OUT and the output voltage value ( $V_{OUT}$ ) of the IC are brought to one other, the more the output voltage remains immune to deviations in the absolute accuracy of externally connected resistances  $R_A$  and  $R_B$  and the absolute value of internal resistances  $R_1$  and  $R_2$  in the IC.

In particular, to suppress the influence of deviations in internal resistances  $R_1$  and  $R_2$  in the IC, a major contributor to deviations in the output OUT, the external resistances  $R_A$  and  $R_B$  must be limited to a much smaller value than that of internal resistances  $R_1$  and  $R_2$  in the IC.

On the other hand, a reactive current flows through external resistances  $R_A$  and  $R_B$ . This reactive current must be reduced to a negligible value with respect to the load current in the actual use of the IC so that the efficiency characteristics will not be degraded. This requires that the value of external resistance  $R_A$  and  $R_B$  be made sufficiently large.

However, too large a value (more than 1 M $\Omega$ ) for the external resistances  $R_A$  and  $R_B$  would make the IC vulnerable to external noise. Check the influence of this value on actual equipment.

There is a tradeoff between the voltage accuracy of the output OUT and the reactive current. This should be taken into consideration based on the requirements of the intended application.

Deviations in the absolute value of internal resistances  $R_1$  and  $R_2$  in the IC vary with the output voltage of the AP1623, and are broadly classified as follows:

. Output voltage 2.5V  $\rightarrow$  4.44M $\Omega$  to 27.0M $\Omega$

. Output voltage 3.3V  $\rightarrow$  3.60M $\Omega$  to 23.3M $\Omega$

. Output voltage 5.0V  $\rightarrow$  2.45M $\Omega$  to 2.45M $\Omega$

When a value of  $R_1 + R_2$  given by the equation indicated below is taken in calculating the voltage value of the output OUT, a median voltage deviation will be obtained for the output OUT.

$$R_1 + R_2 = 2 \div (1 \div \text{maximum deviation in absolute value of internal resistances } R_1 \text{ and } R_2 \text{ in IC} + 1 \div \text{minimum deviation in absolute value of internal resistances } R_1 \text{ and } R_2 \text{ of IC})$$

Moreover, add a capacitor  $C_C$  in parallel to the external resistance  $R_A$  in order to avoid output oscillations and other types of instability.

Make sure that  $C_C$  is larger than the value given by the following equation:

$$C_C(F) \geq 1 \div (2 \times \pi \times R_A (\Omega) \times 7.5kHz)$$

If a large  $C_C$ -value is selected, a longer soft-start time than the one set up in the IC will be set.

### ■ Marking Information

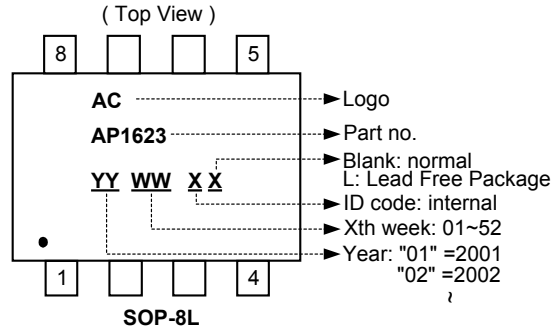

### ■ Package Information

Package Type: SOP-8L

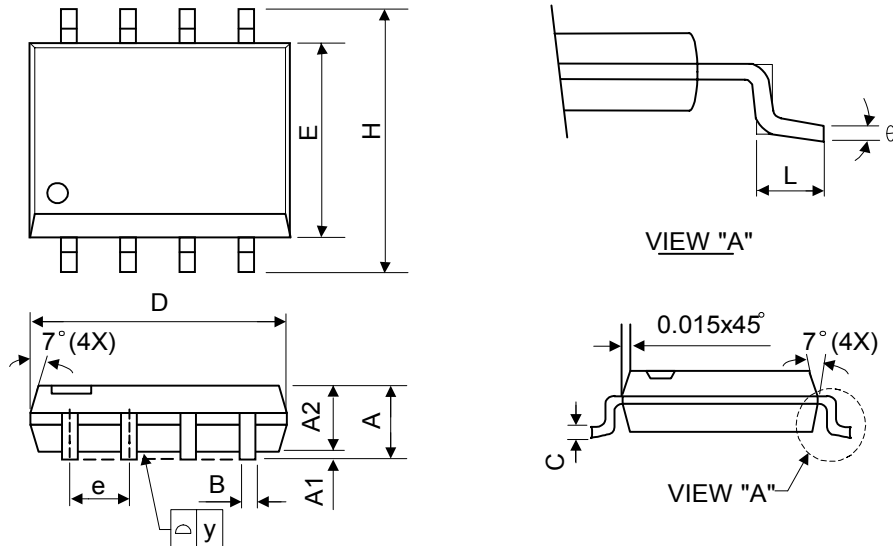

Symbol	Dimensions In Millimeters			Dimensions In Inches		
	Min.	Nom.	Max.	Min.	Nom.	Max.
A	1.40	1.60	1.75	0.055	0.063	0.069
A1	0.10	—	0.25	0.040	—	0.100
A2	1.30	1.45	1.50	0.051	0.057	0.059
B	0.33	0.41	0.51	0.013	0.016	0.020
C	0.19	0.20	0.25	0.0075	0.008	0.010
D	4.80	5.05	5.30	0.189	0.199	0.209
E	3.70	3.90	4.10	0.146	0.154	0.162
e	—	1.27	—	—	0.050	—
H	5.79	5.99	6.20	0.228	0.236	0.244
L	0.38	0.71	1.27	0.015	0.028	0.050
y	—	—	0.10	—	—	0.004
θ	0°	—	8°	0°	—	8°