

Panasonic
ideas for life

**ULTRA SMALL
HIGHLY SEMICONDUCTOR
PRESSURE SENSOR**

**PS PRESSURE
SENSOR**

**Ultra-small
miniature**

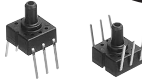

<Actual size>

<Cross-section of Sensor Chip>

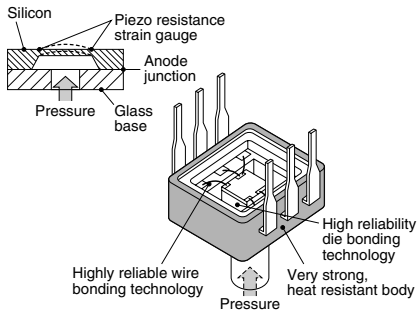

FEATURES

• **Ultra-miniature size: much more compact than the PF pressure sensors offered in the past**

• Base area:

7.2(W) x 7.2(D) mm

.283(W) x .283(D) inch

• Only 60% in mounting area and 91% in overall height of previous models (PF)

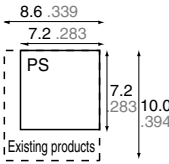

• **High-level precision and linearity**

A high degree of precision and linear detector response have been achieved by applying the semiconductor strain gauge system. Highly reproducible based on repeated pressure.

• **Impressive line-up of models**

• Taking their place alongside the standard 5kΩ bridge resistance models are those with a 3.3kΩ resistance which is optimally suited to 5V drive circuits.

• Economy model (no glass base) gives outstanding value for consumer appliances 40 kPa (0.4 kgf/cm²) and 49 kPa (0.5 kgf/cm²) units are also available.

• **Improved ease of DIP pin insertion into printed circuit boards**

The ends of the DIP pins are chamfered to ensure easy insertion into printed circuit boards.

Example of pressure characteristics

(when the rated pressure is between 98.1 kPa {1.0 kgf/cm²})

Drive current: 1.5 mA rated current; ambient temperature: 25°C 77°F

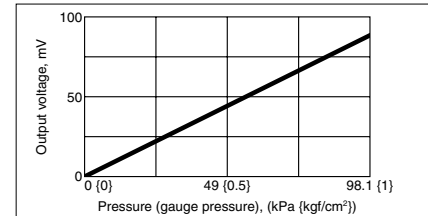

TYPICAL APPLICATIONS

- Medical equipment: Electronic hemodynamometer
- Home appliance: Vacuum cleaner
- Gas equipment: Microprocessor gas meter, gas leakage detector
- Industrial equipment: Absorption device, etc.

ORDERING INFORMATION

Ex. ADP

4

| Part No. | Terminal profile and direction | Rated pressure | Type | Bridge resistance |
|-----------------------------|--|--|---|------------------------|
| ADP4: PS pressure sensor | 1: DIP terminal: Direction opposite the pressure inlet direction | 0: 4.9 kPa {approx. 0.05 kgf/cm ² } | 1 : Standard type (With glass base) 2: Economy type (Without glass base) | 0 : 5.0kΩ 3 : 3.3kΩ |
| | 2: DIP terminal: Pressure inlet direction | 1: 14.7 kPa {approx. 0.15 kgf/cm ² } | | |
| | | 2: 34.3 kPa {approx. 0.35 kgf/cm ² } | | |
| | | 3: 49.0 kPa {approx. 0.5 kgf/cm ² } | | |
| | | 4: 98.1 kPa {approx. 1.0 kgf/cm ² } | | |
| | | 5: 196.1 kPa {approx. 2.0 kgf/cm ² } | | |
| | | 6: 343.2 kPa {approx. 3.5 kgf/cm ² } | | |
| | | 7: 490.3 kPa {approx. 5.0 kgf/cm ² } | | |
| | | 8: 833.6 kPa {approx. 8.5 kgf/cm ² } | | |
| | | 9: 980.7 kPa {approx. 10.0 kgf/cm ² } | | |
| | A: 40.0 kPa {approx. 0.4 kgf/cm ² } | | | |

| Pressure | Bridge resistance | | 5.0kΩ | | 3.3kΩ | | Packing quantity | |
|-----------------------------------|---------------------------------|---|--|---|--|----------|------------------|------------|
| | Terminal | DIP terminal: Direction opposite the pressure inlet direction | DIP terminal: Pressure inlet direction | DIP terminal: Direction opposite the pressure inlet direction | DIP terminal: Pressure inlet direction | Inner | Outer | |
| Standard type (With glass base) | 4.9kPa | approx. 0.05kgf/cm ² | ADP41010 | ADP42010 | — | — | 100 pcs. | 1,000 pcs. |
| | 14.7kPa | approx. 0.15kgf/cm ² | ADP41110 | ADP42110 | — | — | | |
| | 34.3kPa | approx. 0.35kgf/cm ² | ADP41210 | ADP42210 | — | — | | |
| | 49.0kPa | approx. 0.5kgf/cm ² | ADP41310 | ADP42310 | — | — | | |
| | 98.1kPa | approx. 1.0kgf/cm ² | ADP41410 | ADP42410 | ADP41413 | ADP42413 | | |
| | 196.1kPa | approx. 2.0kgf/cm ² | ADP41510 | ADP42510 | — | — | | |
| | 343.2kPa | approx. 3.5kgf/cm ² | ADP41610 | ADP42610 | — | — | | |
| | 490.3kPa | approx. 5.0kgf/cm ² | ADP41710 | ADP42710 | — | — | | |
| | 833.6kPa | approx. 8.5kgf/cm ² | ADP41810 | ADP42810 | — | — | | |
| 980.7kPa | approx. 10.0kgf/cm ² | ADP41910 | ADP42910 | ADP41913 | ADP42913 | | | |
| Economy type (Without glass base) | 40.0kPa | approx. 0.4kgf/cm ² | — | — | ADP41A23 | ADP42A23 | | |
| | 49.0kPa | approx. 0.5kgf/cm ² | ADP41320 | ADP42320 | — | — | | |

SPECIFICATIONS

| | | | | | | | | | | | | | | | | | |
|--|---|-----------|---------|------|------|------|-------|---------|---------|------------------------------|--------------------------|--------------------------|--------------------------------------|------------------------------|--------------------------------|----------|--|
| Type | Standard type (With glass base) | | | | | | | | | | | | Economy type (Without glass base) | | | | |
| Type of pressure | Gauge pressure | | | | | | | | | | | | | | | | |
| Pressure medium | Air (For other medium, please consult us.) | | | | | | | | | | | | | | | | |
| Rated pressure | Unit: kPa | 4.9 | 14.7 | 34.3 | 49.0 | 98.1 | 196.1 | 343.2 | 490.3 | 833.6 | 980.7 | 98.1 | 980.7 | 40.0 | 49.0 | | |
| | Unit: kgf/cm ² (approx.) | 0.05 | 0.15 | 0.35 | 0.5 | 1.0 | 2.0 | 3.5 | 5.0 | 8.5 | 10.0 | 1.0 | 10.0 | 0.4 | 0.5 | | |
| Max. applied pressure | Twice the rated pressure | | | | | | | | | 1.5 times the rated pressure | | Twice the rated pressure | | 1.5 times the rated pressure | | | |
| Bridge resistance | 5000±1000 Ω | | | | | | | | | | 3300±700 Ω | | 3300±600 Ω | | 5000±1000 Ω | | |
| Ambient temperature | -20 to 100°C -4 to 212°F (no freezing or condensation) | | | | | | | | | | | | -5 to +50°C +23 to +122°F | | -20 to +100°C -4 to +212°F | | |
| Storage temperature | -40 to 120°C -40 to 248°F (no freezing or condensation) | | | | | | | | | | | | -20 to +70°C -4 to +158°F | | -40 to +120°C -40 to +248°F | | |
| Temperature compensation range | 0 to 50°C 32 to 122°F | | | | | | | | | | 0 to 60°C 32 to 140°F | | 5 to 45°C 41 to 113°F | | 0 to 50°C 32 to 122°F | | |
| Drive current (constant current) | 1.5 mA DC | | | | | | | | | | 1.0 mA DC | | 1.5 mA DC | | | | |
| Output span voltage | 40±20 mV | 100±40 mV | | | | | | | | | | 65±25 mV | | 43.5±22.5 mV | | 85±45 mV | |
| Offset voltage | ±20 mV | | | | | | | | | | | | | | | | |
| Linearity | ±0.7%FS | ±0.5%FS | ±0.3%FS | | | | | ±0.5%FS | ±0.6%FS | | ±1.0%FS | | ±0.3%FS | | | | |
| Pressure hysteresis | ±0.6%FS | ±0.4%FS | ±0.2%FS | | | | | ±0.4%FS | | ±1.0%FS | | ±0.7%FS | | | | | |
| Offset voltage-temperature characteristics (0 to 50°C 32 to 122°F) | ±15%FS | ±5.0%FS | | | | | | | | | ±3.5%FS | | ±10%FS | ±8%FS | | | |
| Sensitivity-temperature characteristics (0 to 50°C 32 to 122°F) | ±10%FS | ±2.5%FS | | | | | | | | | ±1.3%FS | | ±2.5%FS | | | | |

Notes) 1. Unless otherwise specified, measurements were taken with a drive current of ±0.01 mA and humidity ranging from 25% to 85%.
 2. Please consult us if a pressure medium other than air is to be used.
 3. This is the regulation which applies within the compensation temperature range.
 4. Please consult us if the intended use involves a negative pressure.

DATA

1. Characteristics data

1-<1> Output characteristics

ADP41913

Drive current: 1.0 mA; temperature: 30°C 86°F

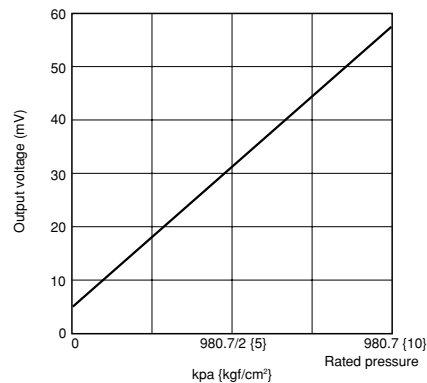

1-<2> Offset voltage – temperature characteristics

ADP41913

Drive current: 1.0 mA; rating ±3.5%FS

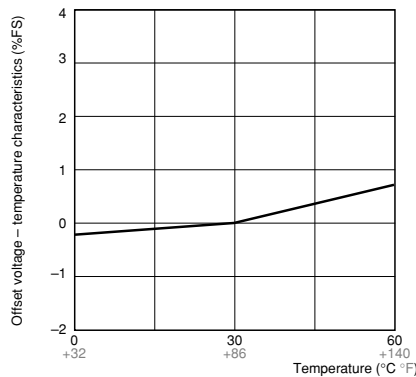

1-<3> Sensitivity – temperature characteristics (%FS)

ADP41913

Drive current: 1.0 mA; rating ±2.5%FS

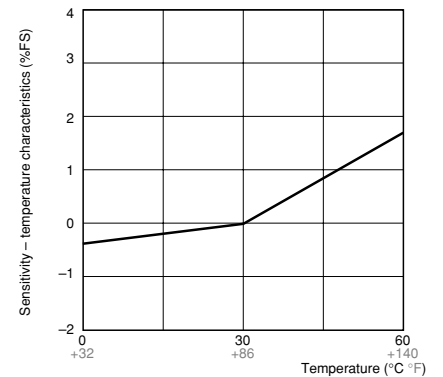

2. Pressure cycle range (0 to rated pressure)

Tested sample: ADP41913, temperature: 100°C 212°F, No. of cycle: 1×10⁶

2-<1> Offset voltage range

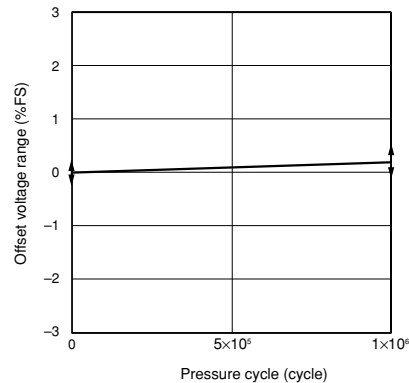

2-<2> Output span voltage range

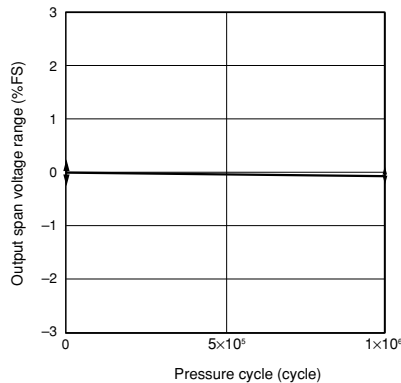

Even after testing for 1 million times, the variations in the offset voltage and output span voltage are minimal.

PS (ADP4)

3. Evaluation test

| Tested item | | Tested condition | Result |
|-------------------------------|--|--|--------|
| Environmental characteristics | Storage at high temperature | Temperature: Left in a 120°C 248°F constant temperature bath Time: 1,000 hrs. | Passed |
| | Storage at low temperature | Temperature: Left in a -40°C -40°F constant temperature bath Time: 1,000 hrs. | Passed |
| | Humidity | Temperature/humidity: Left at 40°C 104°F, 90% RH Time: 1,000 hrs. | Passed |
| | Temperature cycle | Temperature: -40°C to 120°C -40°F to 248°F 1 cycle: 30 min. Times of cycle: 100 | Passed |
| Endurance characteristics | High temperature/high humidity operation | Temperature/humidity: 40°C 104°F, 90% RH Operation times: 10 ⁶ , rated voltage applied | Passed |
| Mechanical characteristics | Vibration resistance | Double amplitude: 1.5 mm .059 inch Vibration: 10 to 55 Hz Applied vibration direction: X, Y, Z 3 directions Times: 2 hrs each | Passed |
| | Dropping resistance | Dropping height: 75 cm 29.528 inch Times: 2 times | Passed |
| | Terminal strength | Pulling strength: 9.8 N {1 kgf}, 10 sec. Bending strength: 4.9 N {0.5 kgf}, left and right 90° 1 time | Passed |
| Soldering Resistance | Soldered in DIP soldering bath | Temperature: 230°C 446°F Time: 5 sec. | Passed |
| | Temperature | Temperature: 260°C 500°F Time: 10 sec. | Passed |

Note: For details other than listed above, please consult us.

DIMENSIONS

General tolerance: $\pm 0.3 \pm 0.12$ mm inch

1. Terminal direction: Direction opposite the pressure inlet direction ADP41□□□

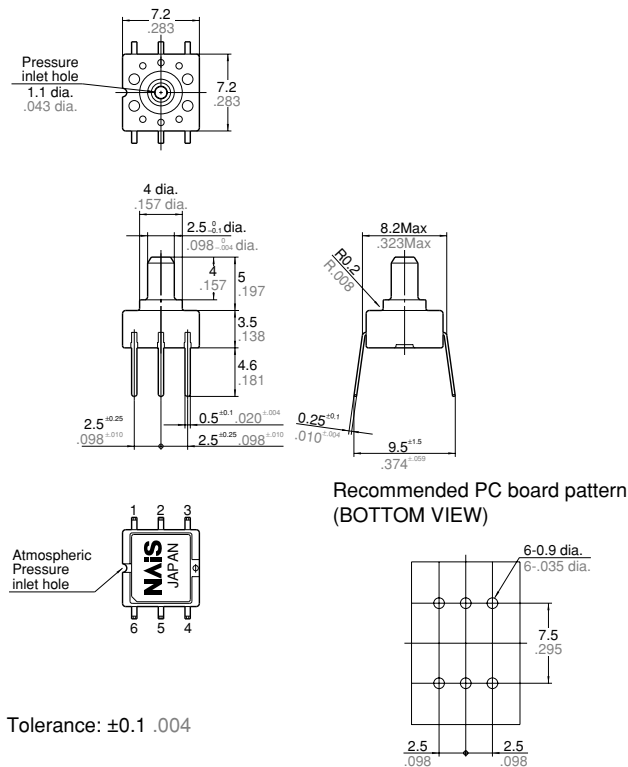

2. Terminal direction: Pressure inlet direction ADP42□□□

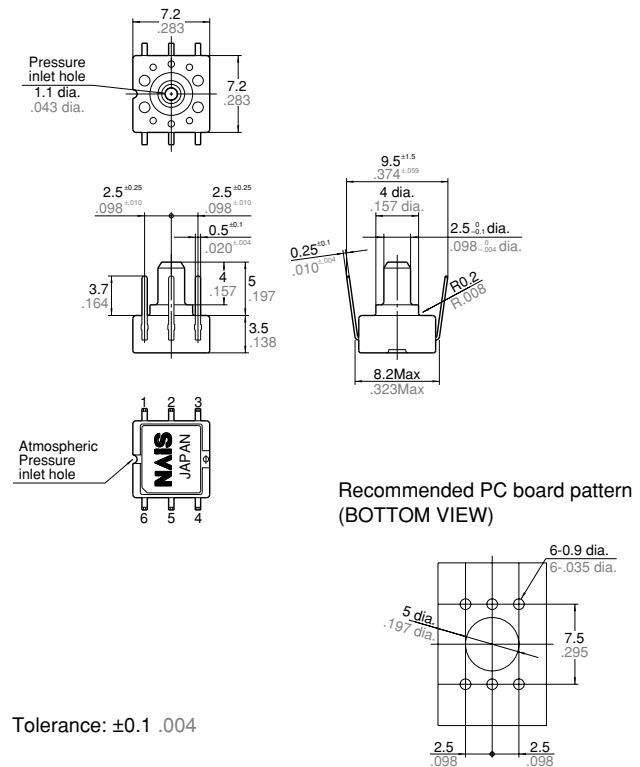

3. Terminal connection diagram

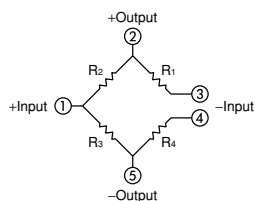

| Terminal No. | Name |
|--------------|------------------|
| 1 | Power supply (+) |
| 2 | Output (+) |
| 3 | Power supply (-) |
| 4 | Power supply (-) |
| 5 | Output (-) |
| 6 | No connection |

Note: Leave terminal 6 unconnected.

NOTES

1. Mounting

Use lands on the printed-circuit boards to which the sensor can be securely fixed.

2. Soldering

1) Due to its small size, the thermal capacity of the pressure sensor DIP type is low. Therefore, take steps to minimize the effects of external heat.

Dip soldering bath: Max. 260°C 500°F, 5 sec.

Soldering iron: 260 to 300°C 500 to 572°F (30W) within 5 sec.

2) Use a non-corrosive resin type of flux. Since the pressure sensor DIP type is exposed to the atmosphere, do not allow flux to enter inside.

3. Cleaning

1) Since the pressure sensor chip is exposed to the atmosphere, do not allow cleaning fluid to enter inside.

2) Avoid ultrasonic cleaning since this may cause breaks or disconnections in the wiring.

4. Environment

Consult with us before using or storing the pressure sensor chip in a place exposed to corrosive gases (such as the gases given off by organic solvents, sulfites, hydrogen sulfides, etc.) which will adversely affect the performance of the pressure sensor chip.

5. Quality check under actual loading conditions

1) To assure reliability, check the sensor under actual loading conditions. Avoid any situation that may adversely affect its performance.

2) As for test data, please contact us.

6. Other handling precautions

1) That using the wrong pressure range or mounting method may result in accidents.

2) Air can be used directly as a pressure medium. Consult with us before using a corrosive gas (such as a gas given off by an organic solvent, sulfite or hydrogen sulfide) as the pressure medium.

3) The pressure sensor chip is positioned inside the pressure inlet. Never poke wires or other foreign matter through the pressure inlet since they may damage the chip or block the inlet. Avoid use when the atmospheric pressure inlet is blocked.

4) Leave pin No. 6 unconnected since the pressure sensor chip may be damaged if a voltage is applied to this pin.

5) Use an operating pressure which is within the rated pressure range. Using a pressure beyond this range may cause damage.

6) Since this pressure sensor chip does not have a water-proof construction, consult with us if it is to be used in a location where it may be sprayed with water, etc.

7) Avoid using the pressure sensor chip in an environment where condensation may form. Furthermore, its output may fluctuate if any moisture adhering to it freezes.

8) The pressure sensor chip is constructed in such a way that its output will fluctuate when it is exposed to light. Especially when pressure is to be applied by means of a transparent tube, take steps to prevent the pressure sensor chip from being exposed to light.

9) Avoid using the pressure sensor chip where it will be susceptible to ultrasonic or other high-frequency vibration.

10) Since static charge can damage the pressure sensor chip, bear in mind the following handling precautions.

- When storing the pressure sensor chips, use a conductive material to short the pins or wrap the entire chip in aluminum foil. Plastic containers should not be used to store or transport the chips since they readily become charged.

- When using the pressure sensor chips, all the charged articles on the bench surface and the work personnel should be grounded so that any ambient static will be safely discharged.

11) Due to the pressures involved, give due consideration to the securing of the pressure sensor DIP type and to the securing and selection of the inlet tube. Consult us if you have any queries.

APPLICATION CIRCUIT DIAGRAM (EXAMPLE)

The pressure sensor is designed to convert a voltage by means of constant current drive and then, if necessary, it amplifies the voltage for use. The circuit shown below is a typical example of a circuit in which the pressure sensor is used.

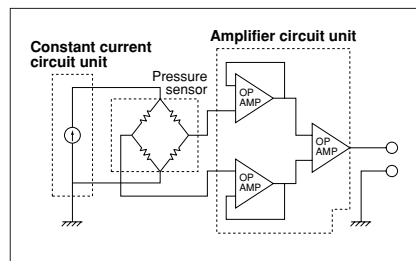

MOUNTING METHOD

The general method for transmitting air pressures differs depending on whether the pressure is low or high.

• Checkpoints for use

- <1> Select a pressure inlet pipe which is sturdy enough to prevent pressure leaks.
- <2> Fix the pressure inlet pipe securely so as to prevent pressure leaks.
- <3> Do not block the pressure inlet pipe.

Methods of transmitting air pressures

