

## 5V-0.5A VERY LOW DROP REGULATOR WITH RESET

- PRECISE OUTPUT VOLTAGE ( $5V \pm 4\%$ ) OVER FULL TEMPERATURE RANGE ( $-40 / 125\text{ }^{\circ}\text{C}$ )
- VERY LOW VOLTAGE DROP ( $0.75V_{\text{max}}$ ) OVER FULL T RANGE
- OUTPUT CURRENT UP TO 500mA
- RESET FUNCTION
- POWER-ON RESET DELAY PULSE DEFINED BY THE EXTERNAL CAPACITOR
- + 80V LOAD DUMP PROTECTION
- - 80V LOAD DUMP PROTECTION
- REVERSE VOLTAGE PROTECTION
- SHORT CIRCUIT PROTECTION AND THERMAL SHUT-DOWN (with hysteresis)
- LOW START UP CURRENT

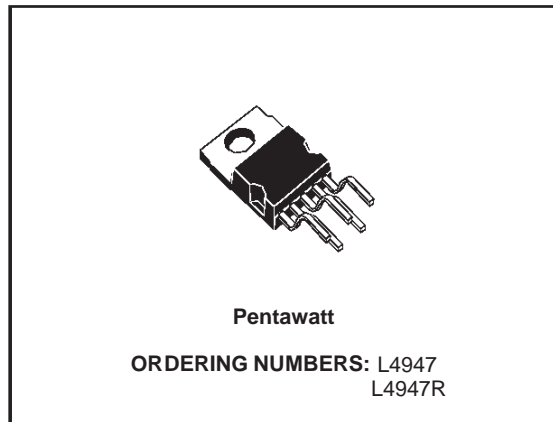

### DESCRIPTION

The L4947/L4947R is a monolithic integrated circuit in Pentawatt package specially designed to provide a stabilized supply voltage for automotive and industrial electronic systems. Thanks to its very low voltage drop, in automotive applications the L4947/L4947R can work correctly even during the cranking phase, when the battery voltage

could fall as low as 6V. Furthermore, it incorporates a complete range of protection circuits against the dangerous overvoltages always present on the battery rail of the car. The reset function makes the device particularly suited to supply microprocessor based systems : a signal is available (after an externally programmable delay) to reset the microprocessor at power-on phase ; at power-off, this signal becomes low inhibiting the microprocessor.

### BLOCK DIAGRAM

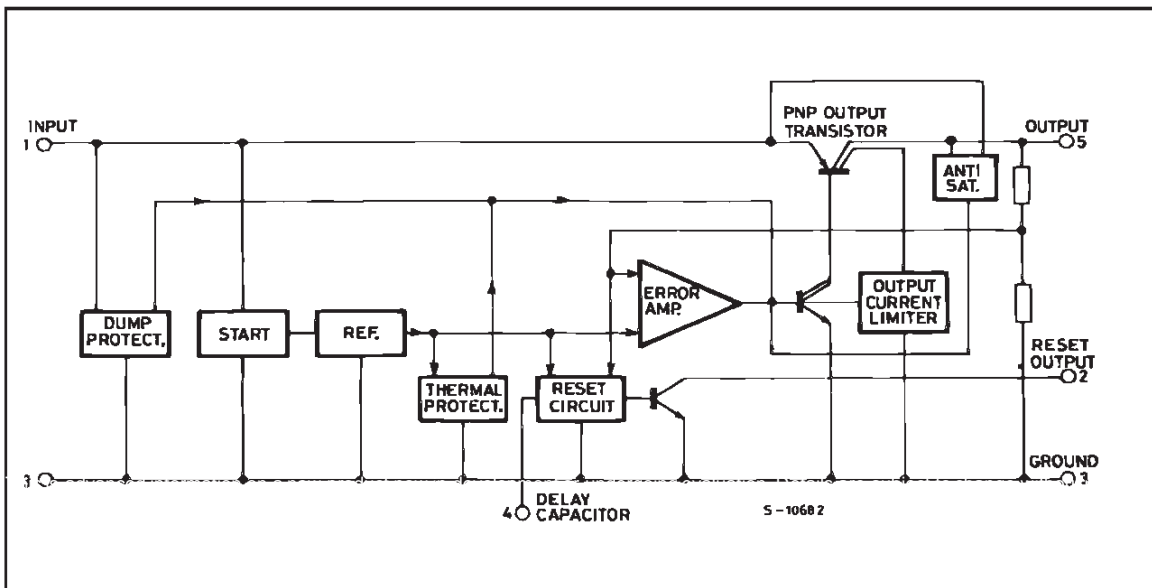

## L4947 - L4947R

### ABSOLUTE MAXIMUM RATINGS

Symbol	Parameter	Value	Unit
$V_i$	DC Input Voltage	35	V
	DC Reverse Input Voltage	- 18	V
	Transient Input Overvoltages : Load Dump :	80	V
	$5\text{ms} \leq t_{\text{rise}} \leq 10\text{ms}$ $\tau_f$ Fall Time Constant = 100ms $R_{\text{SOURCE}} \geq 0.5\Omega$	- 80	V
	Field Decay : $5\text{ms} \leq t_{\text{fall}} \leq 10\text{ms}$ , $R_{\text{SOURCE}} \geq 10\Omega$ $\tau_r$ Rise Time Constant = 33ms	$\pm 100$	V
$V_R$	Reset Output Voltage	35	V
	$T_J$ , $T_{\text{stg}}$	- 55 to 150	$^{\circ}\text{C}$

Note: The circuit is ESD protected according to MIL-STD-883C.

### PIN CONNECTION (Top view)

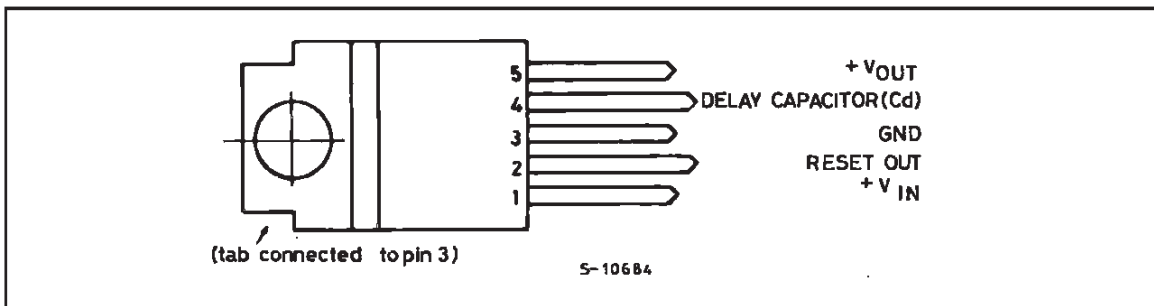

### THERMAL DATA

Symbol	Parameter	Value	Unit
$R_{\text{th j-case}}$	Thermal Resistance Junction-case	Max 3.5	$^{\circ}\text{C/W}$

### TEST CIRCUIT

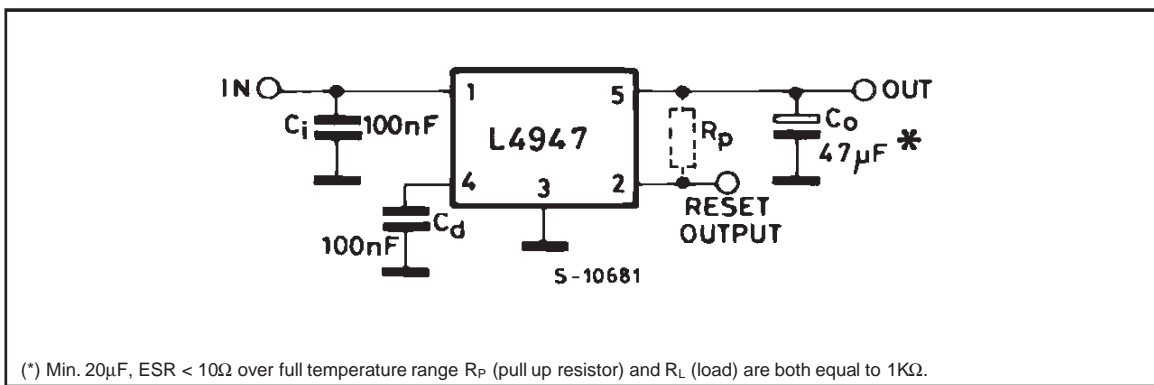

(\*) Min. 20µF, ESR < 10Ω over full temperature range  $R_P$  (pull up resistor) and  $R_L$  (load) are both equal to 1KΩ.

**ELECTRICAL CHARACTERISTICS** (refer to the test circuit,  $V_i = 14.4\text{V}$ ,  $C_o = 47\mu\text{F}$ ,  $\text{ESR} < 10\Omega$ ,  $R_p = 1\text{K}\Omega$ ,  $R_L = 1\text{K}\Omega$ ,  $-40^\circ\text{C} \leq T_J \leq 125^\circ\text{C}$ , unless otherwise specified)

Symbol	Parameter	Test Conditions	Min.	Typ.	Max.	Unit
$V_o$	Output Voltage	$I_o = 0\text{mA}$ to $500\text{mA}$ Over Full T Range	4.80	5.00	5.20	V
		$T_J = 25^\circ\text{C}$	4.90	5.00	5.10	V
$V_i$	Operating Input Voltage	$I_o = 0\text{mA}$ to (*) $500\text{mA}$	6		26	V
$\Delta V_o$	Line Regulation	$V_i = 6\text{V}$ to $26\text{V}$ ; $I_o = 5\text{mA}$		2	10	mV
$\Delta V_o$	Load Regulation	$I_o = 5\text{mA}$ to $500\text{mA}$		15	60	mV
$V_i - V_o$	Dropout Voltage	$I_o = 500\text{mA}$ , $T_J = 25^\circ\text{C}$ Over Full T Range		0.40	0.55	V
					0.75	V
$I_q$	Quiescent Current	$I_o = 0\text{mA}$ , $T_J = 25^\circ\text{C}$ $I_o = 0\text{mA}$ Over Full T $I_o = 500\text{mA}$ Over Full T		5	10	mA
				6.5	13	mA
				110	180	mA
$\frac{\Delta V_o}{T}$	Temperature Output Voltage Drift			-0.5		mV/°C
SVR	Supply Volt. Rej.	$I_o = 350\text{mA}$ ; $f = 120\text{Hz}$ $C_o = 100\mu\text{F}$ ; $V_i = 12\text{V} \pm 5V_{pp}$	50	60		dB
$I_{sc}$	Output Short Circuit Current		0.50	0.80	1.50	A
$V_R$	Reset Output Saturation Voltage	$1.5\text{V} < V_o < V_{RT(\text{off})}$ , $I_R = 1.6\text{mA}$			0.40	V
		$3.0\text{V} < V_o < V_{RT(\text{off})}$ , $I_R = 8\text{mA}$			0.40	V
$I_R$	Reset Output Leakage Current	$V_o$ in Regulation, $V_R = 5\text{V}$			50	$\mu\text{A}$
$V_{RT \text{ peak}}$	Power On-Off Reset out Peak Voltage	$1\text{K}\Omega$ Reset Pull-up to $V_o$ , $T_J = 25^\circ\text{C}$		0.50	0.80	V
$V_{RT(\text{off})}$	Power OFF $V_o$ Threshold	$T_J = 25^\circ\text{C}$ <b>L4947</b> : $V_o$ @ Reset Out H to L Transition	4.70 4.75	$V_o - 0.15$		V V
		<b>L4947R</b> : $V_o$ @ Reset Out H to L Transition	4.55	$V_o - 0.30$		V
$V_{RT(\text{on})}$	Power ON $V_o$ Threshold	$V_o$ @ Reset Out L to H Transition		$V_{RT(\text{off})} + 0.05$	$V_o - 0.04$	V
$V_{Hyst}$	Power ON-Off Hysteresis	$V_{RT(\text{on})} - V_{RT(\text{off})}$		0.05		V
$V_d$	Delay Comparator Threshold	$V_d$ @ Reset Out L to H Transition	3.65	4.00	4.35	V
		$V_d$ @ Reset Out H to L Transition	3.20	3.55	3.90	V
$V_{dH}$	Delay Comparator Hysteresis			0.45		V
$I_d$	Delay Capacitor Charging Current	$V_d = 3\text{V}$ , $T_J = 25^\circ\text{C}$		20		$\mu\text{A}$
$V_{disch}$	Delay Capacitor Discharge Voltage	$V_o < V_{RT(\text{off})}$		0.55	1.20	V
$T_d$	Power on Reset Delay Time	$C_d = 100\text{nF}$ , $T_J = 25^\circ\text{C}$	10	20	30	ms

(\*) For a DC voltage  $26 < V_i < 37\text{V}$  the device is not operating

## FUNCTIONAL DESCRIPTION

The L4947/L4947R is a very low drop 5V/0.5A voltage regulator provided with a reset function and therefore particularly suited to meet the requirements of supplying the microprocessor systems used in automotive and industrial applications.

The block diagram shows the basic structure of the device : the reference, the error amplifier, the

driver, the power PNP, the protection and reset functions.

The power stage is a Lateral PNP transistor which allows a very low dropout voltage (typ. 400mV at  $T_J = 25^\circ\text{C}$ , max. 750mV over the full temperature range @  $I_o = 500\text{mA}$ ). The typical curve of the dropout voltage as a function of the junction temperature is shown in Fig. 1 : that is the worst case, where  $I_o = 500\text{mA}$ .







Information furnished is believed to be accurate and reliable. However, STMicroelectronics assumes no responsibility for the consequences of use of such information nor for any infringement of patents or other rights of third parties which may result from its use. No license is granted by implication or otherwise under any patent or patent rights of STMicroelectronics. Specification mentioned in this publication are subject to change without notice. This publication supersedes and replaces all information previously supplied. STMicroelectronics products are not authorized for use as critical components in life support devices or systems without express written approval of STMicroelectronics.

The ST logo is a registered trademark of STMicroelectronics  
© 2000 STMicroelectronics – Printed in Italy – All Rights Reserved  
STMicroelectronics GROUP OF COMPANIES

Australia - Brazil - China - Finland - France - Germany - Hong Kong - India - Italy - Japan - Malaysia - Malta - Morocco -  
Singapore - Spain - Sweden - Switzerland - United Kingdom - U.S.A.

<http://www.st.com>