

## Very low drop 1.5 A regulator

### Features

- Precise 5, 8.5, 10, 12 V outputs
- Low dropout voltage (450 mV typ. at 1 A)
- Very low quiescent current
- Thermal shutdown
- Short circuit protection
- Reverse polarity protection

### Description

The L4940 series of three terminal positive regulators is available in TO-220, TO-220FP and D<sup>2</sup>PAK packages and with several fixed output voltages, making it useful in a wide range of industrial and consumer applications. Thanks to its very low input/output voltage drop, these devices are particularly suitable for batteries powered equipment, reducing consumption and

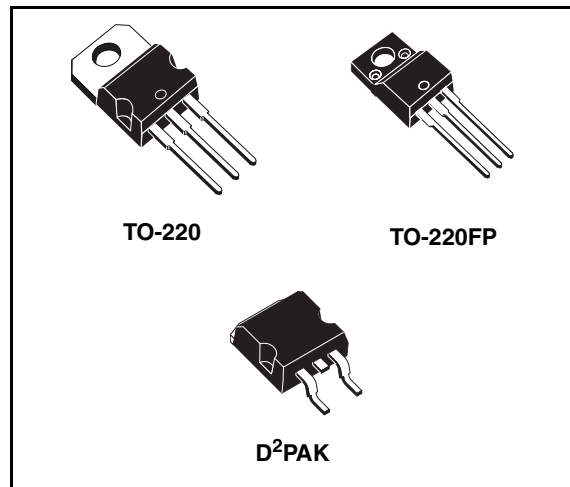

prolonging battery life. Each type employs internal current limiting, antisaturation circuit, thermal shut-down and safe area protection.

**Table 1. Device summary**

Part number	Order code			Output voltage
	TO-220	TO-220FP	D <sup>2</sup> PAK	
L4940xx5	L4940V5		L4940D2T5-TR	5 V
L4940xx85	L4940V85	L4940P85	L4940D2T85-TR	8.5 V
L4940xx10			L4940D2T10-TR	10 V
L4940xx12			L4940D2T12-TR	12 V

---

## Contents

1	Block diagram .....	3
2	Pin configuration .....	4
3	Maximum ratings .....	5
4	Test circuits .....	6
5	Electrical characteristics .....	7
6	Typical application .....	11
7	Schematic application .....	15
8	Package mechanical data .....	17
9	Revision history .....	22

# 1 Block diagram

Figure 1. Block diagram

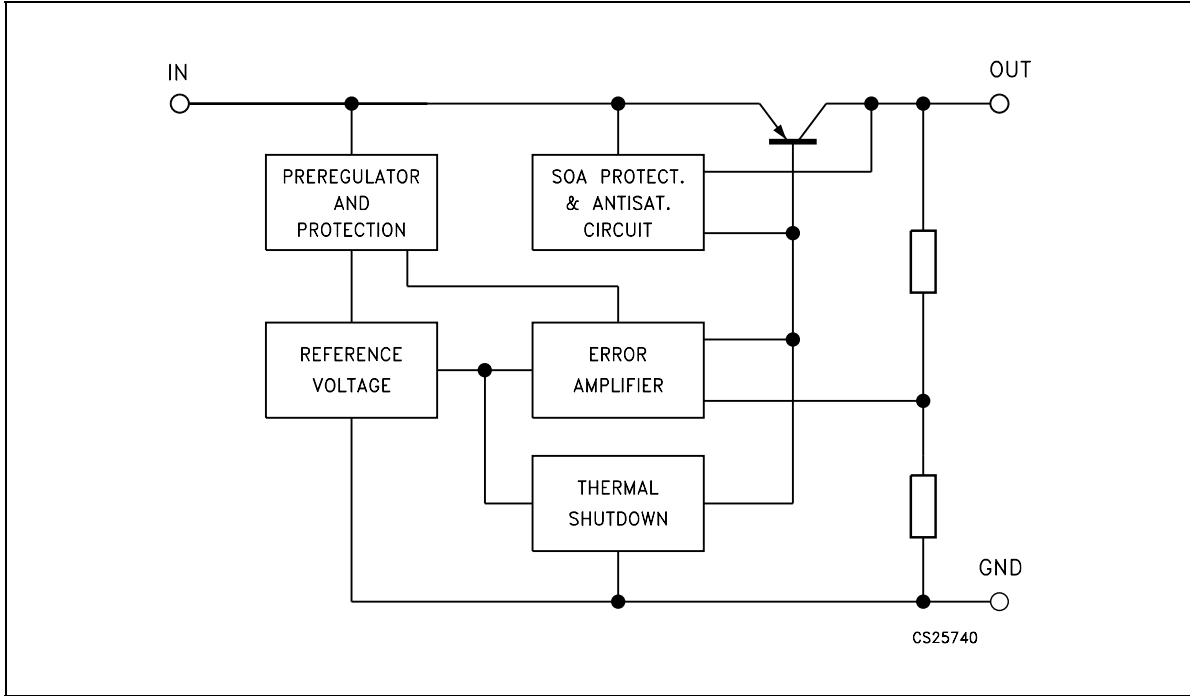

## 2 Pin configuration

Figure 2. Pin connections (top view)

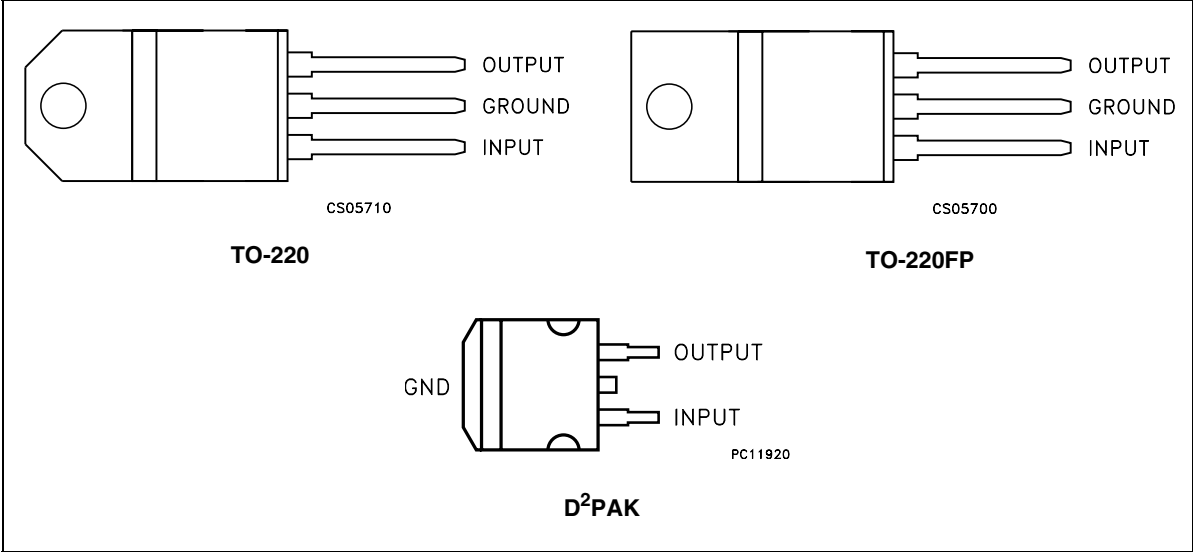

### 3 Maximum ratings

**Table 2. Absolute maximum ratings**

Symbol	Parameter	Value	Unit	
$V_I$	Forward input voltage	30	V	
$V_{IR}$	Reverse input voltage	$V_O = 5V, R_O = 100\Omega$	-15	V
		$V_O = 8.5V, R_O = 180\Omega$	-15	V
		$V_O = 10V, R_O = 200\Omega$	-15	V
		$V_O = 12V, R_O = 240\Omega$	-15	V
$I_O$	Output current	Internally Limited	mA	
$P_D$	Power dissipation	Internally Limited	mW	
$T_{stg}$	Storage temperature range	-40 to +150	°C	
$T_{op}$	Operating junction temperature range	-40 to +150	°C	

*Note: Absolute maximum ratings are those values beyond which damage to the device may occur. Functional operation under these condition is not implied.*

**Table 3. Thermal data**

Symbol	Parameter	TO-220	TO-220FP	D <sup>2</sup> PAK	Unit
$R_{thJC}$	Thermal resistance junction-case	3	5	3	°C/W
$R_{thJA}$	Thermal resistance junction-ambient	50	60	62.5	°C/W

## 4 Test circuits

Figure 3. DC parameters

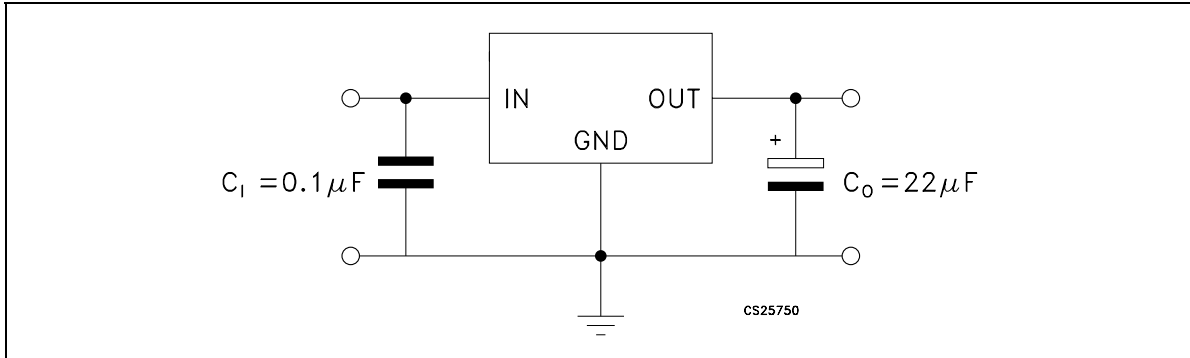

Figure 4. Load rejection

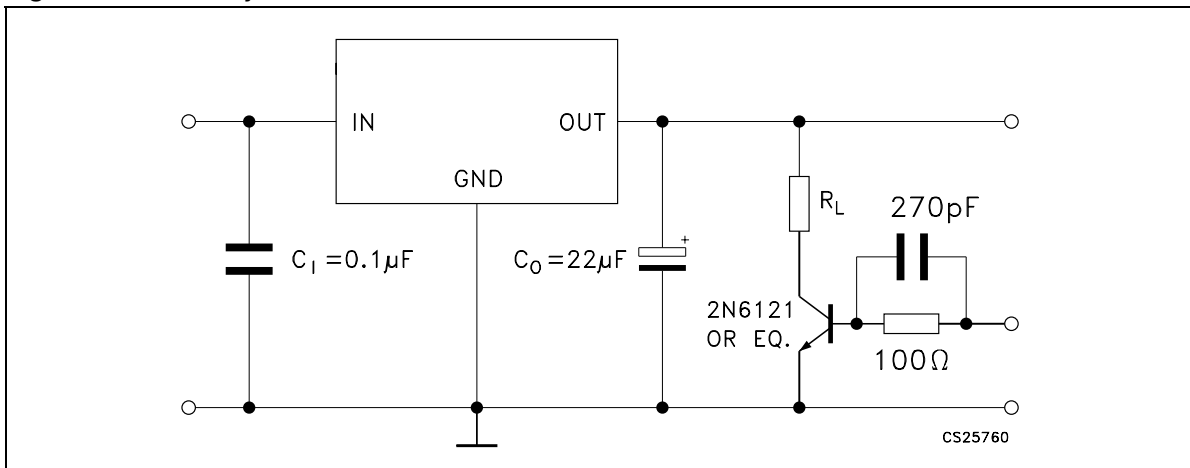
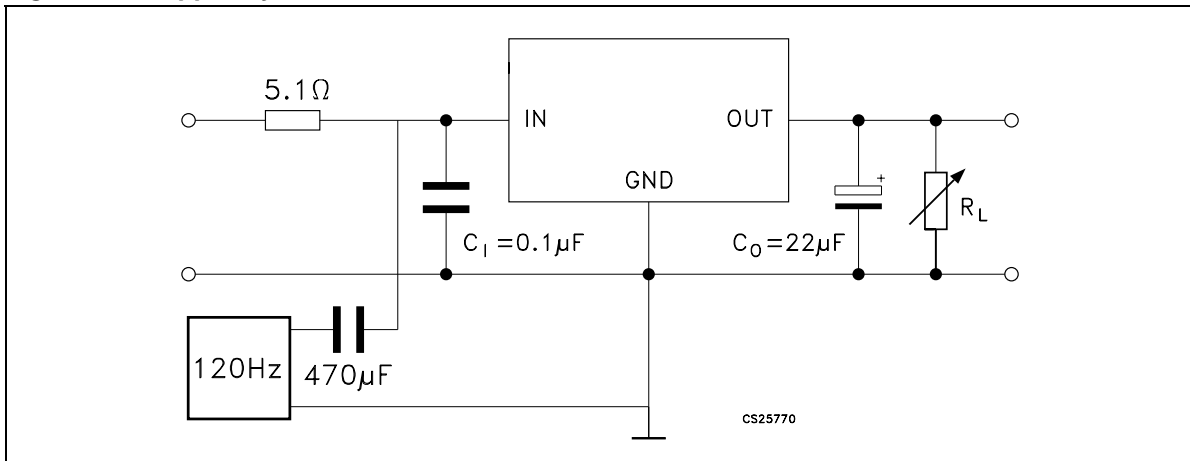

Figure 5. Ripple rejection



## 5 Electrical characteristics

**Table 4. Electrical characteristics of L4940xx5** (Refer to test circuit,  $V_I = 7\text{ V}$ ,  $C_I = 0.1\ \mu\text{F}$ ,  $C_O = 22\ \mu\text{F}$ ,  $T_J = 25^\circ\text{C}$ , unless otherwise specified.)

Symbol	Parameter	Test conditions	Min.	Typ.	Max.	Unit
$V_O$	Output voltage	$I_O = 500\text{ mA}$	4.9	5	5.1	V
$V_O$	Output voltage	$I_O = 5\text{ mA to } 1.5\text{ A}$ , $V_I = 6.5\text{ to } 15\text{ V}$	4.8	5	5.2	V
$V_I$	Input voltage	$I_O = 5\text{ mA}$			17	V
$\Delta V_O$	Line regulation	$V_I = 6\text{ to } 17\text{ V}$ , $I_O = 5\text{ mA}$		4	10	mV
$\Delta V_O$	Load regulation	$I_O = 5\text{ mA to } 1.5\text{ A}$		8	25	mV
		$I_O = 0.5\text{ A to } 1\text{ A}$		5	15	mV
$I_q$	Quiescent current	$I_O = 5\text{ mA}$		5	8	mA
		$I_O = 1.5\text{ A}$ , $V_I = 6.5\text{ V}$		30	50	mA
$\Delta I_q$	Quiescent current change	$I_O = 5\text{ mA}$			3	mA
		$I_O = 1.5\text{ A}$ , $V_I = 6.5\text{ to } 16\text{ V}$			15	mA
$\Delta V_O/\Delta T$	Output voltage drift			0.5		mV/°C
SVR	Supply voltage rejection	$f = 120\text{ Hz}$ , $I_O = 1\text{ A}$	58	68		dB
$V_d$	Dropout voltage	$I_O = 0.5\text{ A}$		200	400	mV
		$I_O = 1.5\text{ A}$		500	900	mV
$I_{sc}$	Short circuit current	$V_I = 14\text{ V}$		2	2.7	A
		$V_I = 6.5\text{ V}$		2.2	2.9	

**Table 5. Electrical characteristics of L4940xx85** (Refer to test circuit,  $V_I = 10.5\text{ V}$ ,  $C_I = 0.1\ \mu\text{F}$ ,  $C_O = 22\ \mu\text{F}$ ,  $T_J = 25^\circ\text{C}$ , unless otherwise specified.)

Symbol	Parameter	Test conditions	Min.	Typ.	Max.	Unit
$V_O$	Output voltage	$I_O = 500\text{ mA}$	8.3	8.5	8.7	V
$V_O$	Output voltage	$I_O = 5\text{ mA to } 1.5\text{ A}$ , $V_I = 10.2\text{ to } 15\text{ V}$	8.15	8.5	8.85	V
$V_I$	Input voltage	$I_O = 5\text{ mA}$			17	V
$\Delta V_O$	Line regulation	$V_I = 9.5\text{ to } 17\text{ V}$ , $I_O = 5\text{ mA}$		4	9	mV
$\Delta V_O$	Load regulation	$I_O = 5\text{ mA to } 1.5\text{ A}$		12	30	mV
		$I_O = 0.5\text{ A to } 1\text{ A}$		8	16	mV
$I_q$	Quiescent current	$I_O = 5\text{ mA}$		4	8	mA
		$I_O = 1.5\text{ A}$ , $V_I = 10.2\text{ V}$		30	50	mA
$\Delta I_q$	Quiescent current change	$I_O = 5\text{ mA}$			2.5	mA
		$I_O = 1.5\text{ A}$ , $V_I = 10.2\text{ to } 16\text{ V}$			15	mA
$\Delta V_O/\Delta T$	Output voltage drift			0.8		mV/°C
SVR	Supply voltage rejection	$f = 120\text{ Hz}$ , $I_O = 1\text{ A}$	58	66		dB
$V_d$	Dropout voltage	$I_O = 0.5\text{ A}$		200	400	mV
		$I_O = 1.5\text{ A}$		500	900	mV
$I_{sc}$	Short circuit current	$V_I = 14\text{ V}$		2	2.7	A
		$V_I = 10.2\text{ V}$		2.2	2.9	



**Table 6. Electrical characteristics of L4940xx10** (Refer to test circuit,  $V_I = 12\text{V}$ ,  $C_1 = 0.1\ \mu\text{F}$ ,  $C_O = 22\ \mu\text{F}$ ,  $T_J = 25^\circ\text{C}$ , unless otherwise specified.)

Symbol	Parameter	Test conditions	Min.	Typ.	Max.	Unit
$V_O$	Output voltage	$I_O = 500\ \text{mA}$	9.8	10	10.2	V
$V_O$	Output voltage	$I_O = 5\ \text{mA}$ to $1.5\ \text{A}$ , $V_I = 11.7$ to $15\ \text{V}$	9.6	10	10.4	V
$V_I$	Input voltage	$I_O = 5\ \text{mA}$			17	V
$\Delta V_O$	Line regulation	$V_I = 11$ to $17\ \text{V}$ , $I_O = 5\ \text{mA}$		3	8	mV
$\Delta V_O$	Load regulation	$I_O = 5\ \text{mA}$ to $1.5\ \text{A}$		15	35	mV
		$I_O = 0.5\ \text{A}$ to $1\ \text{A}$		10	20	mV
$I_q$	Quiescent current	$I_O = 5\ \text{mA}$		5	8	mA
		$I_O = 1.5\ \text{A}$ , $V_I = 11.7\ \text{V}$		30	50	mA
$\Delta I_q$	Quiescent current change	$I_O = 5\ \text{mA}$			2	mA
		$I_O = 1.5\ \text{A}$ , $V_I = 11.7$ to $16\ \text{V}$			13	mA
$\Delta V_O/\Delta T$	Output voltage drift			1		mV/ $^\circ\text{C}$
SVR	Supply voltage rejection	$f = 120\ \text{Hz}$ , $I_O = 1\ \text{A}$	56	62		dB
$V_d$	Dropout voltage	$I_O = 0.5\ \text{A}$		200	400	mV
		$I_O = 1.5\ \text{A}$		500	900	mV
$I_{sc}$	Short circuit current	$V_I = 14\ \text{V}$		2	2.7	A
		$V_I = 11.7\ \text{V}$		2.2	2.9	

**Table 7. Electrical characteristics of L4940xx12** (Refer to test circuit,  $V_I = 14\text{ V}$ ,  $C_I = 0.1\text{ }\mu\text{F}$ ,  $C_O = 22\text{ }\mu\text{F}$ ,  $T_J = 25^\circ\text{C}$ , unless otherwise specified.)

Symbol	Parameter	Test conditions	Min.	Typ.	Max.	Unit
$V_O$	Output voltage	$I_O = 500\text{ mA}$	11.75	12	12.25	V
$V_O$	Output voltage	$I_O = 5\text{ mA to }1.5\text{ A}$ , $V_I = 11.7\text{ to }15\text{ V}$	11.5	12	12.5	V
$V_I$	Input voltage	$I_O = 5\text{ mA}$			17	V
$\Delta V_O$	Line regulation	$V_I = 11\text{ to }17\text{ V}$ , $I_O = 5\text{ mA}$		3	7	mV
$\Delta V_O$	Load regulation	$I_O = 5\text{ mA to }1.5\text{ A}$		15	35	mV
		$I_O = 0.5\text{ A to }1\text{ A}$		10	25	mV
$I_q$	Quiescent current	$I_O = 5\text{ mA}$		4	8	mA
		$I_O = 1.5\text{ A}$ , $V_I = 11.7\text{ V}$		30	50	mA
$\Delta I_q$	Quiescent current change	$I_O = 5\text{ mA}$			1.5	mA
		$I_O = 1.5\text{ A}$ , $V_I = 11.7\text{ to }16\text{ V}$			10	mA
$\Delta V_O/\Delta T$	Output voltage drift			1.2		mV/°C
SVR	Supply voltage rejection	$f = 120\text{ Hz}$ , $I_O = 1\text{ A}$	55	61		dB
$V_d$	Dropout voltage	$I_O = 0.5\text{ A}$		200	400	mV
		$I_O = 1.5\text{ A}$		500	900	mV
$I_{sc}$	Short circuit current	$V_I = 14\text{ V}$		2	2.7	A
$Z_O$	Output impedance	$f = 120\text{ Hz}$ , $I_O = 0.5\text{ A}$		40		m $\Omega$

## 6 Typical application

Figure 6. Dropout voltage vs output current

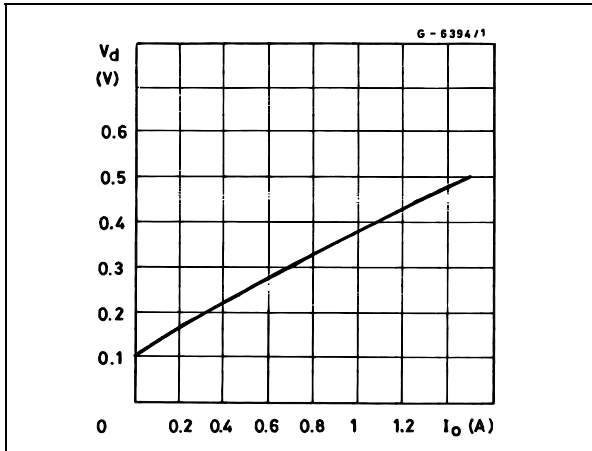

Figure 7. Dropout voltage vs temperature

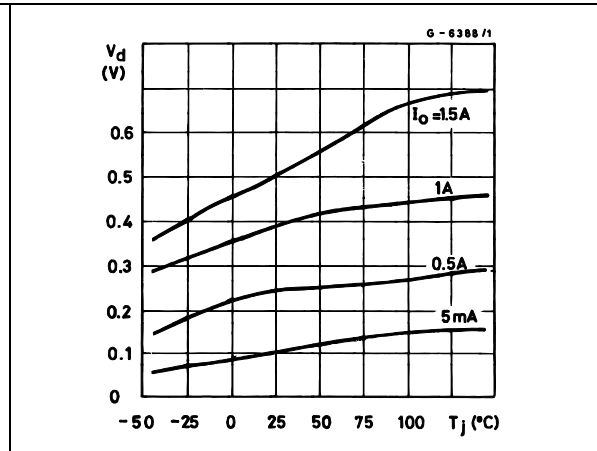

Figure 8. Output voltage vs temperature (L4940V5)

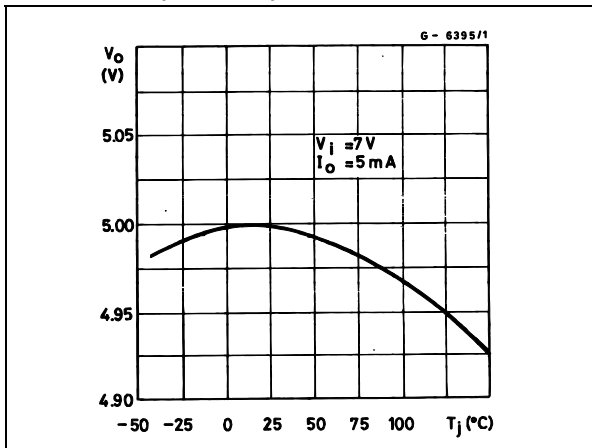

Figure 9. Output voltage vs temperature (L4940V85)

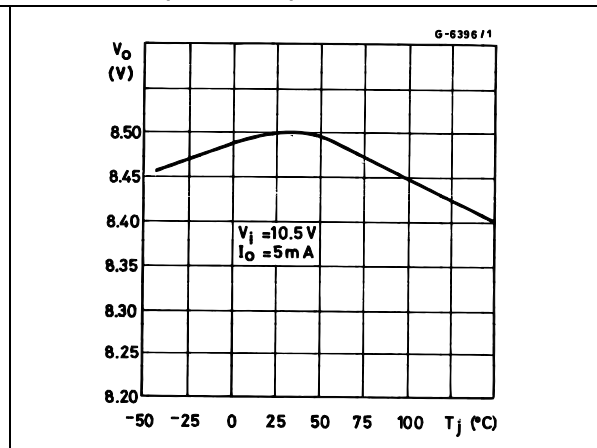

Figure 10. Output voltage vs temperature (L4940V10)

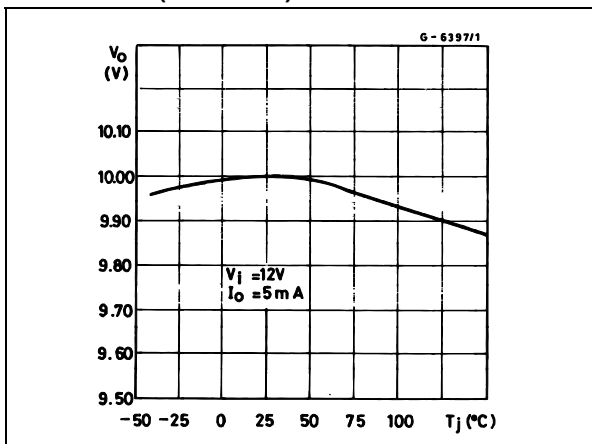

Figure 11. Output voltage vs temperature (L4940V12)

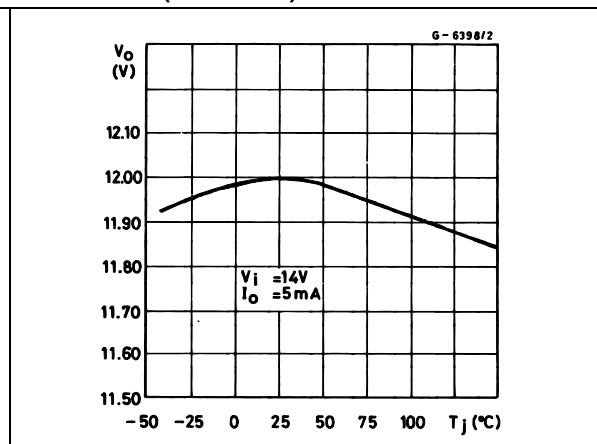

Figure 12. Quiescent current vs temperature (L4940V5)

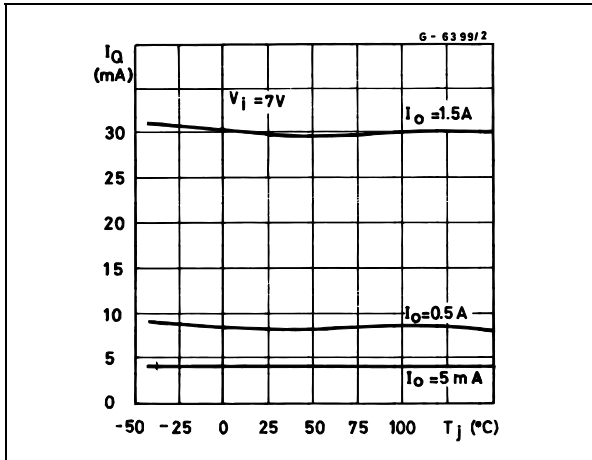

Figure 13. Quiescent current vs input voltage (L4940V5)

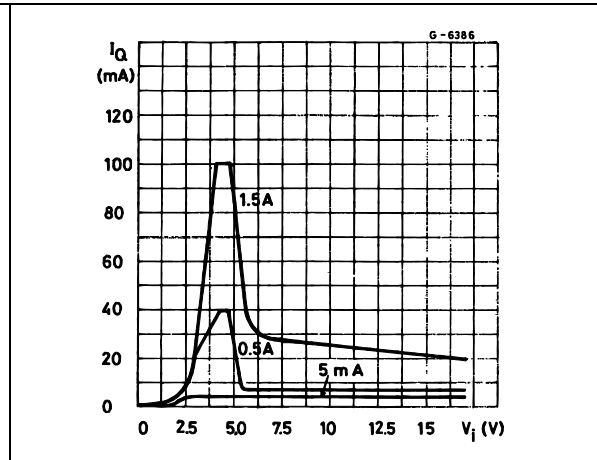

Figure 14. Quiescent current vs output current (L4940V5)

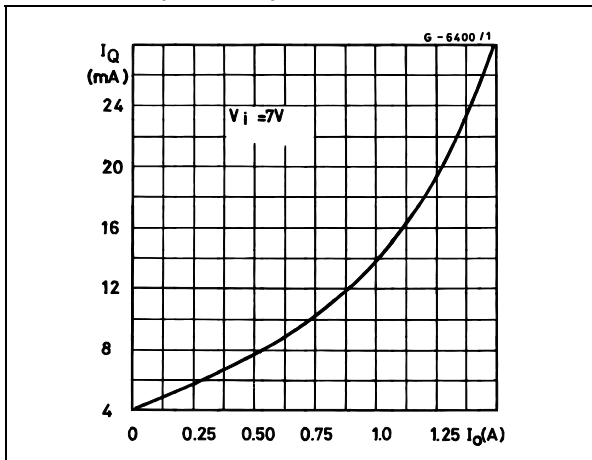

Figure 15. Short circuit current vs temperature (L4940V5)

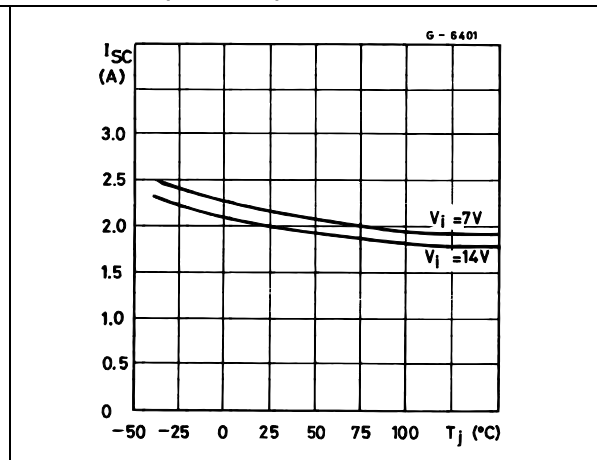

Figure 16. Peak output current vs input/output differential voltage (L4940V5)

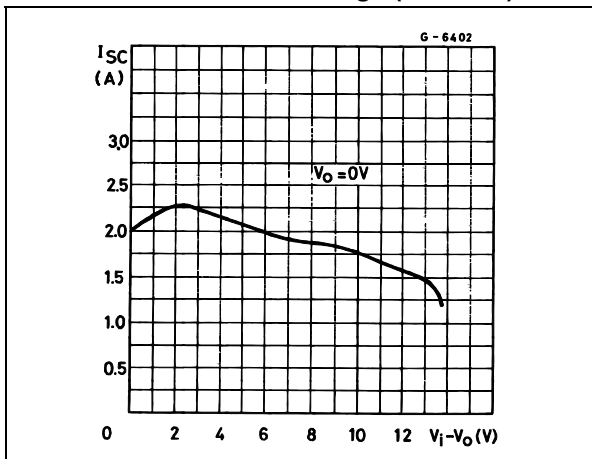

Figure 17. Low voltage behavior (L4940V5)

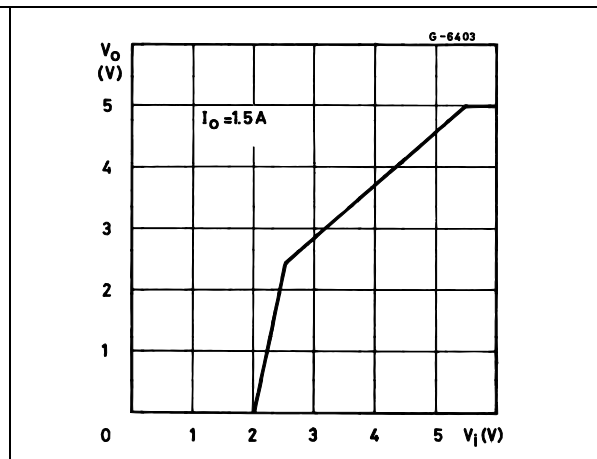

Figure 18. Low voltage behavior (L4940V85)

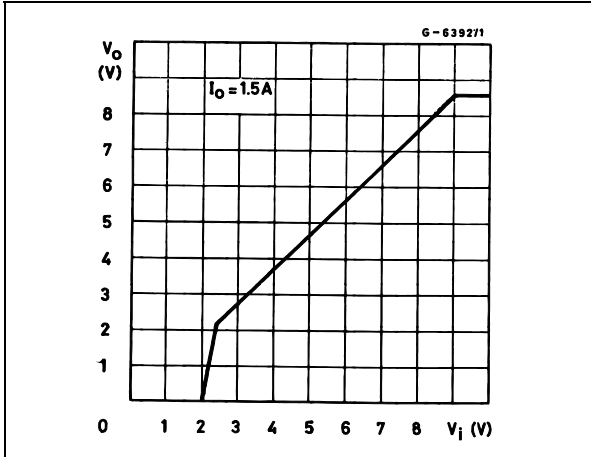

Figure 19. Low voltage behavior (L4940V10)

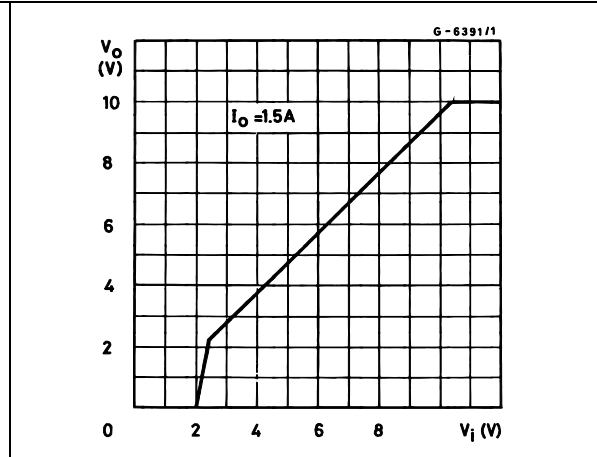

Figure 20. Low voltage behavior (L4940V12)

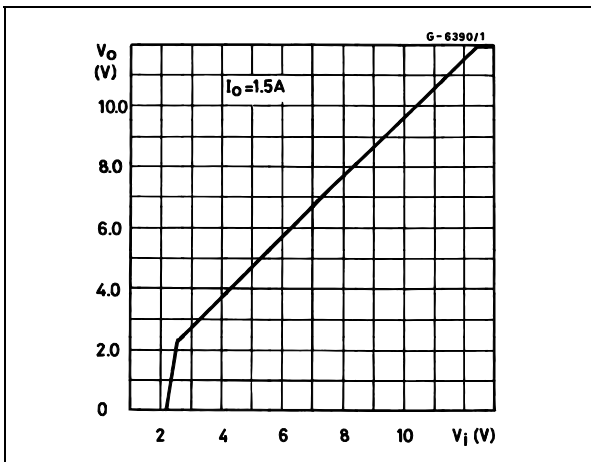

Figure 21. Supply voltage rejection vs frequency (L4940V5)

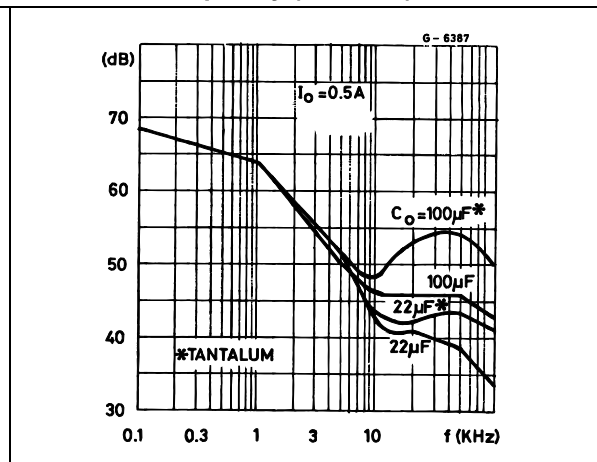

Figure 22. Supply voltage rejection vs output current (L4940V5)

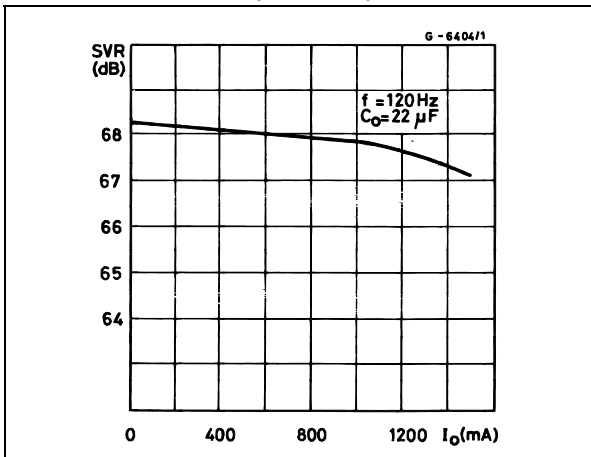

Figure 23. Lad dump characteristics (L4940V5)

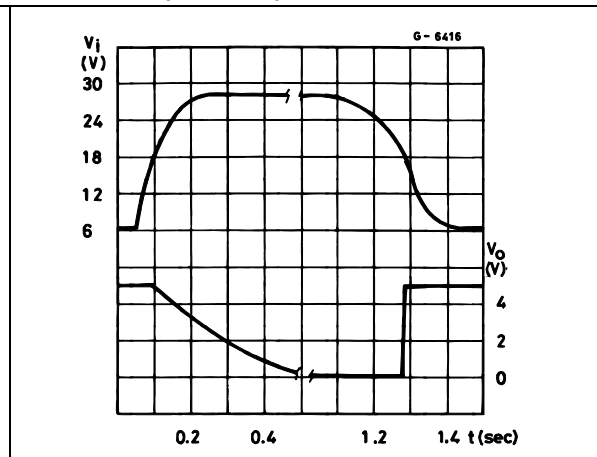

Figure 24. Line transient response (L4940V5) Figure 25. Total power dissipation

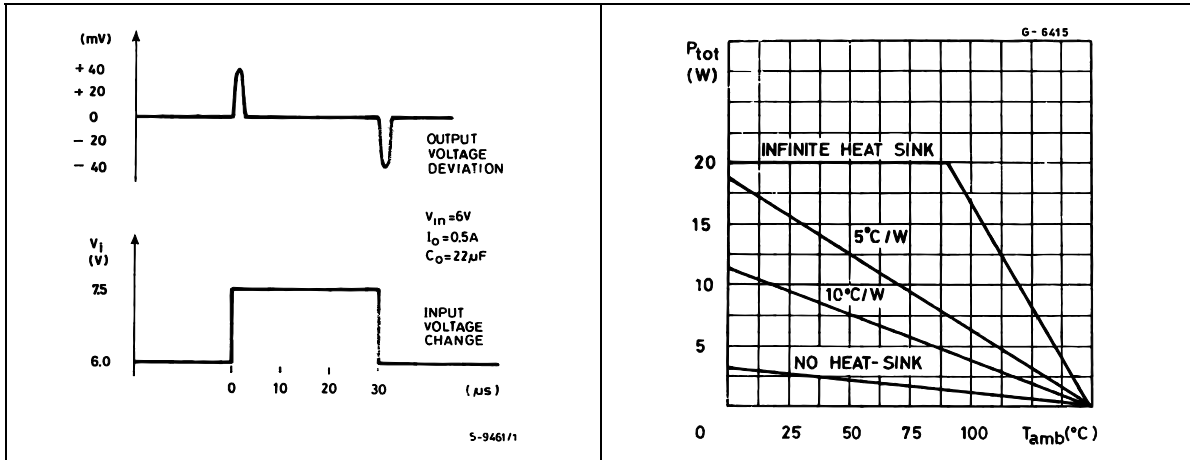
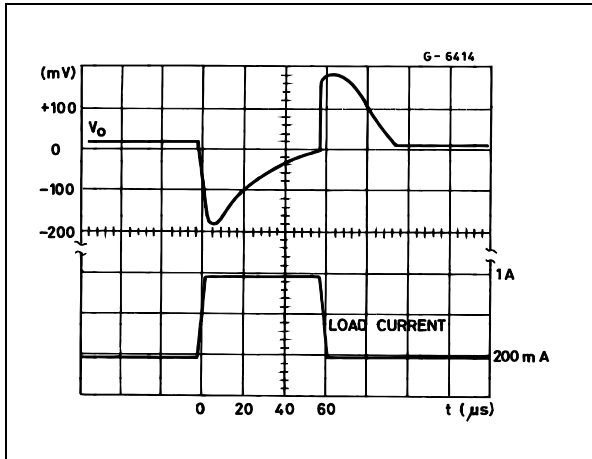

Figure 26. Load transient response



## 7 Schematic application

Figure 27. Distributed supply with On-card L4940 and L4941 low drop regulator

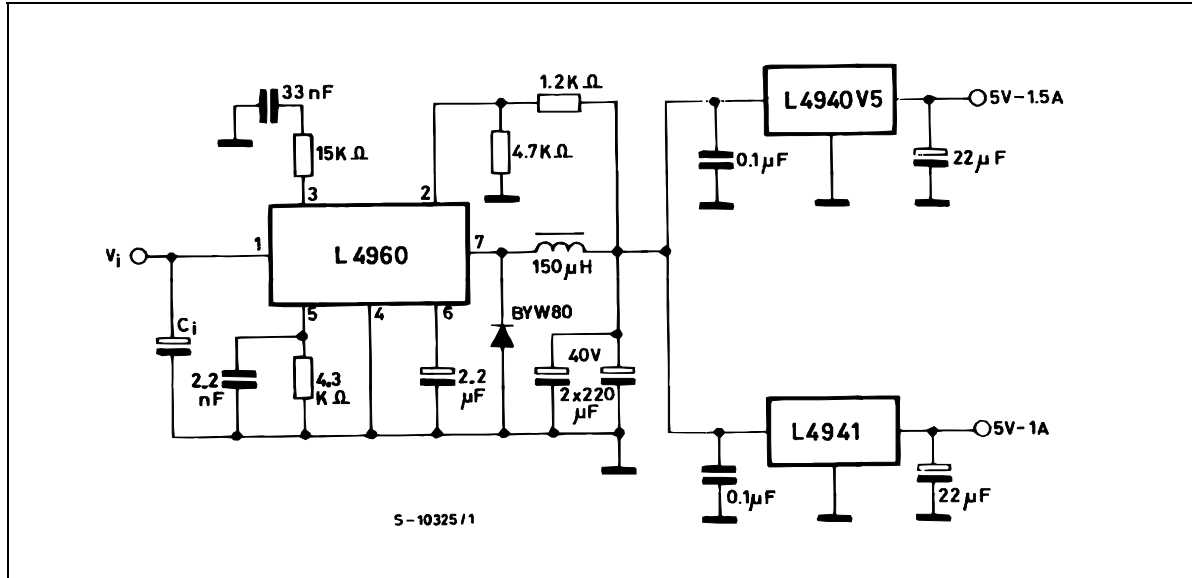
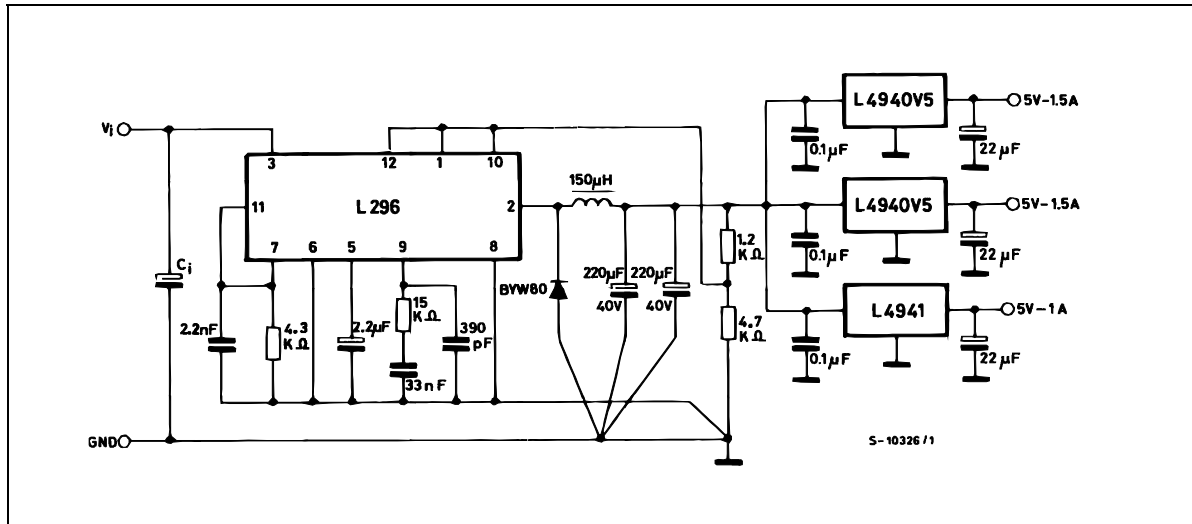

Figure 28. Distributed supply with On-card L4940 and L4941 low drop regulator



ADVANTAGES OF THESE APPLICATION ARE:

On card regulation with short-circuit and thermal protection on each output.

Vary high total system efficiency due to the switching pre-regulation and very low-drop post-regulation.

Figure 29. Distributed supply with On-card L4940 and L4941 low drop regulator

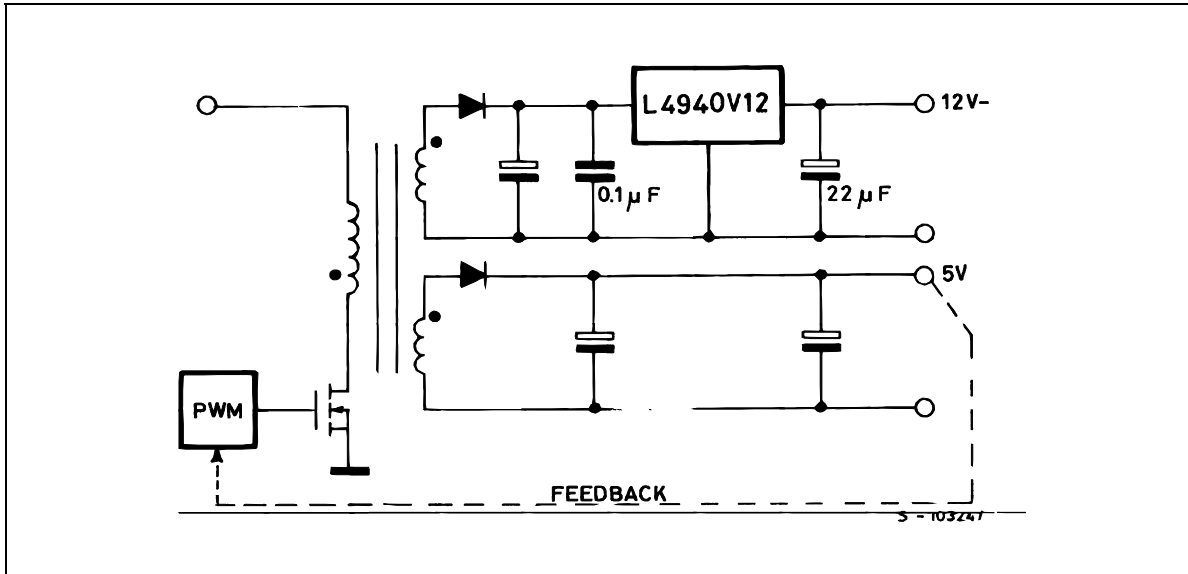

## ADVANTAGES OF THIS CONFIGURATION ARE:

Very high regulation (line and load on both the output voltage)

12V output short circuit and thermally protected

Very high efficiency on the 12 V output due to the low drop regulator



## 8 Package mechanical data

In order to meet environmental requirements, ST offers these devices in ECOPACK<sup>®</sup> packages. These packages have a lead-free second level interconnect. The category of second Level Interconnect is marked on the package and on the inner box label, in compliance with JEDEC Standard JESD97. The maximum ratings related to soldering conditions are also marked on the inner box label. ECOPACK is an ST trademark. ECOPACK specifications are available at: [www.st.com](http://www.st.com).

**TO-220 mechanical data**

Dim.	mm.			inch.		
	Min.	Typ.	Max.	Min.	Typ.	Max.
A	4.40		4.60	0.173		0.181
C	1.23		1.32	0.048		0.051
D	2.40		2.72	0.094		0.107
D1		1.27			0.050	
E	0.49		0.70	0.019		0.027
F	0.61		0.88	0.024		0.034
F1	1.14		1.70	0.044		0.067
F2	1.14		1.70	0.044		0.067
G	4.95		5.15	0.194		0.203
G1	2.4		2.7	0.094		0.106
H2	10.0		10.40	0.393		0.409
L2		16.4			0.645	
L4	13.0		14.0	0.511		0.551
L5	2.65		2.95	0.104		0.116
L6	15.25		15.75	0.600		0.620
L7	6.2		6.6	0.244		0.260
L9	3.5		3.93	0.137		0.154
DIA.	3.75		3.85	0.147		0.151

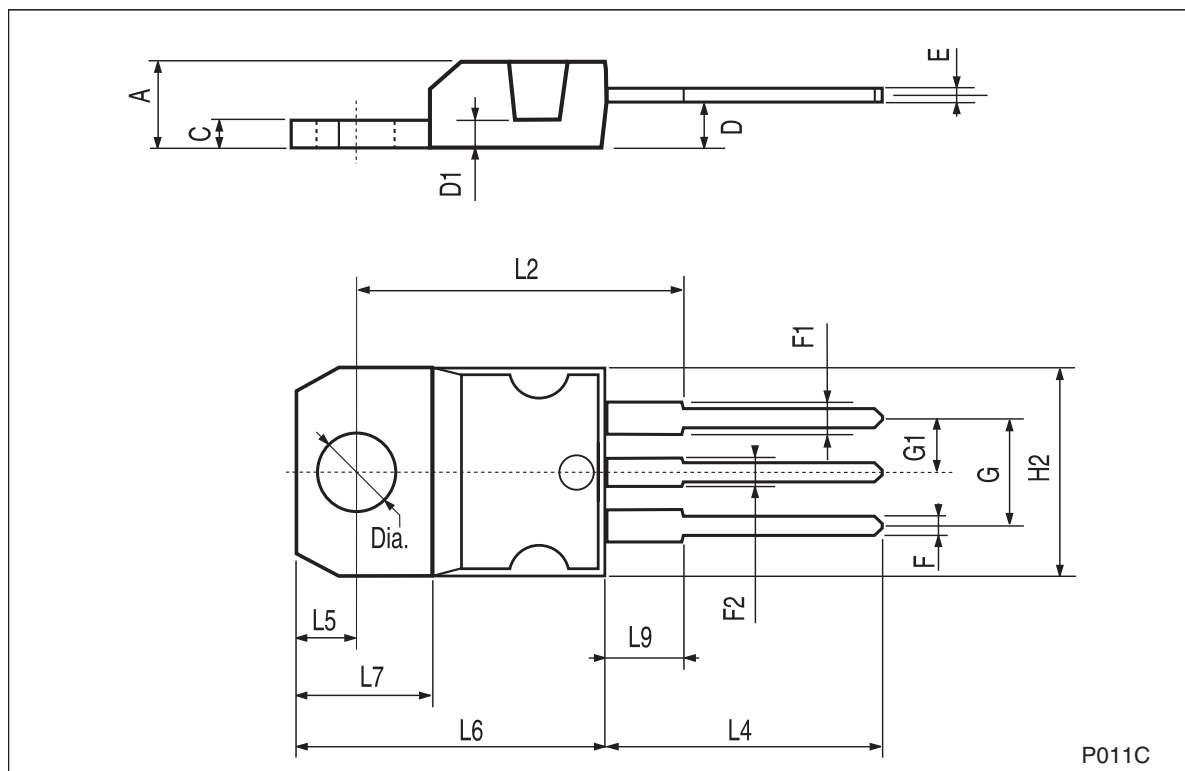

P011C

## TO-220FP mechanical data

Dim.	mm.			inch.		
	Min.	Typ	Max.	Min.	Typ.	Max.
A	4.40		4.60	0.173		0.181
B	2.5		2.7	0.098		0.106
D	2.5		2.75	0.098		0.108
E	0.45		0.70	0.017		0.027
F	0.75		1	0.030		0.039
F1	1.15		1.50	0.045		0.059
F2	1.15		1.50	0.045		0.059
G	4.95		5.2	0.194		0.204
G1	2.4		2.7	0.094		0.106
H	10.0		10.40	0.393		0.409
L2		16			0.630	
L3	28.6		30.6	1.126		1.204
L4	9.8		10.6	0.385		0.417
L5	2.9		3.6	0.114		0.142
L6	15.9		16.4	0.626		0.645
L7	9		9.3	0.354		0.366
DIA.	3		3.2	0.118		0.126

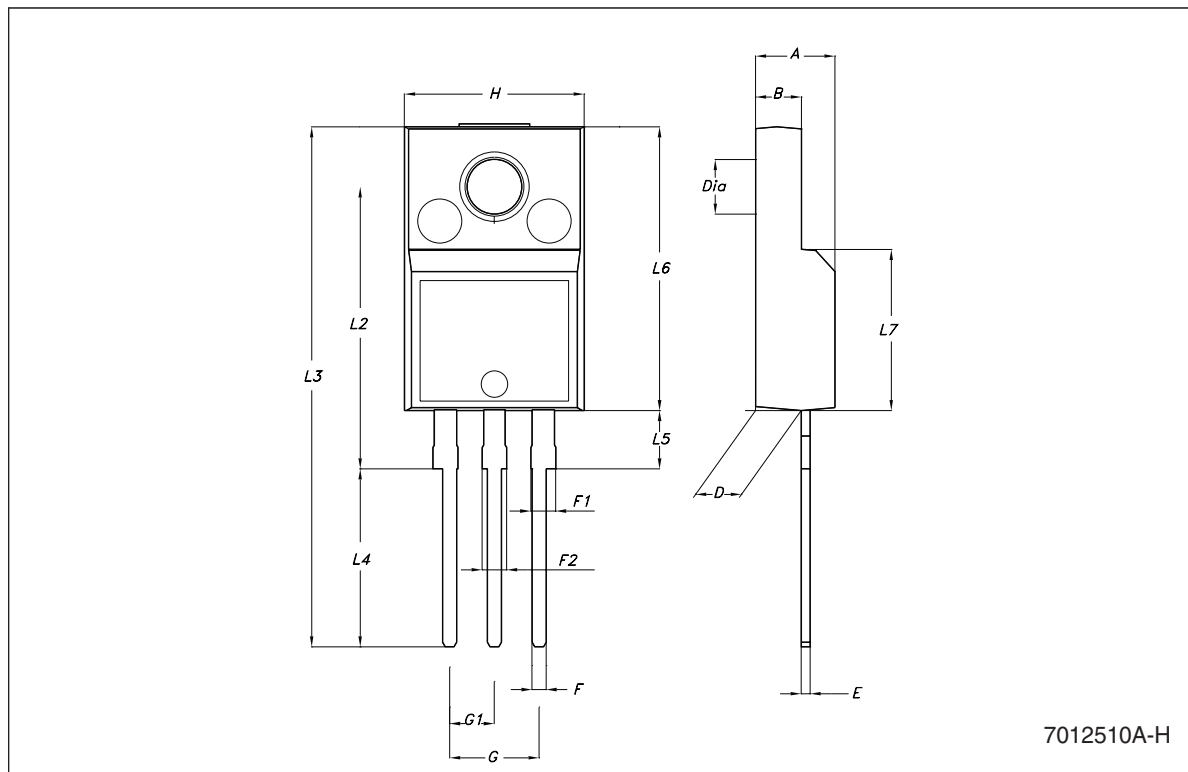

**D<sup>2</sup>PAK mechanical data**

Dim.	mm.			inch.		
	Min.	Typ.	Max.	Min.	Typ.	Max.
A	4.4		4.6	0.173		0.181
A1	2.49		2.69	0.098		0.106
A2	0.03		0.23	0.001		0.009
B	0.7		0.93	0.027		0.036
B2	1.14		1.7	0.044		0.067
C	0.45		0.6	0.017		0.023
C2	1.23		1.36	0.048		0.053
D	8.95		9.35	0.352		0.368
D1		8			0.315	
E	10		10.4	0.393		0.409
E1		8.5			0.335	
G	4.88		5.28	0.192		0.208
L	15		15.85	0.590		0.624
L2	1.27		1.4	0.050		0.055
L3	1.4		1.75	0.055		0.068
M	2.4		3.2	0.094		0.126
R		0.4			0.016	
V2	0°		8°	0°		8°

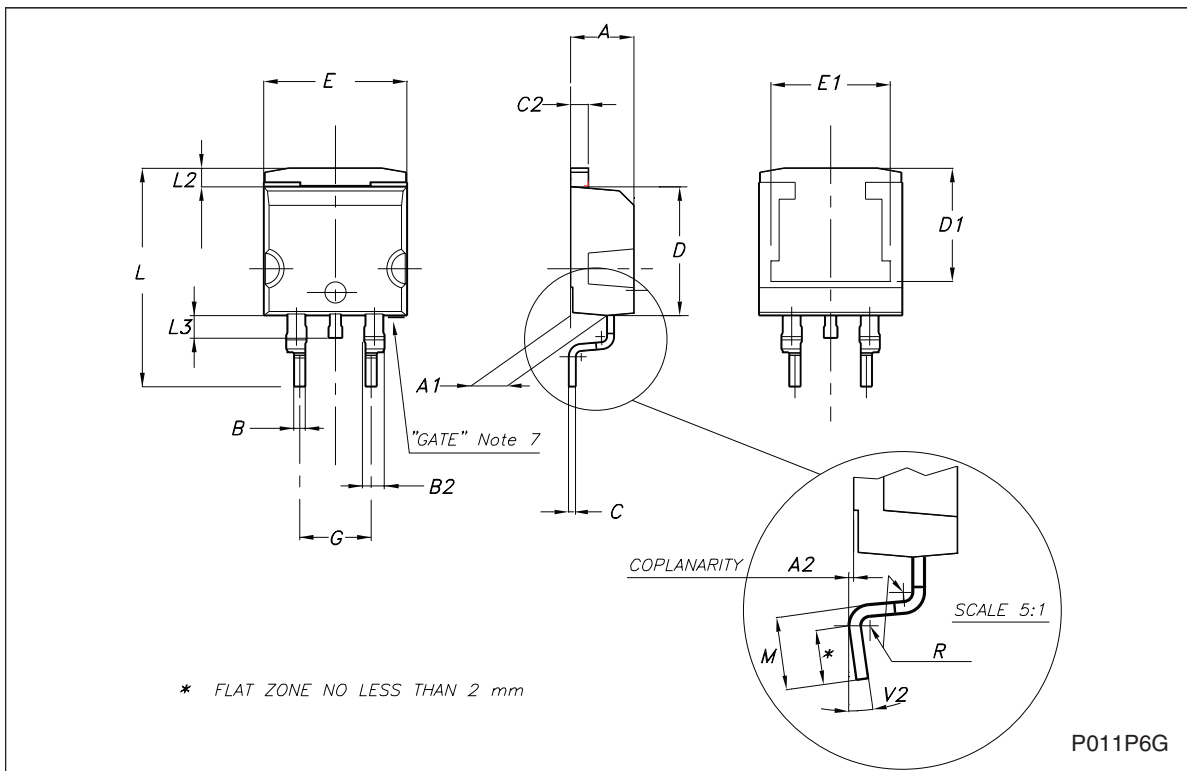

Tape & reel D<sup>2</sup>PAK-P<sup>2</sup>PAK-D<sup>2</sup>PAK/A-P<sup>2</sup>PAK/A mechanical data

Dim.	mm.			inch.		
	Min.	Typ.	Max.	Min.	Typ.	Max.
A			180			7.086
C	12.8	13.0	13.2	0.504	0.512	0.519
D	20.2			0.795		
N	60			2.362		
T			14.4			0.567
Ao	10.50	10.6	10.70	0.413	0.417	0.421
Bo	15.70	15.80	15.90	0.618	0.622	0.626
Ko	4.80	4.90	5.00	0.189	0.193	0.197
Po	3.9	4.0	4.1	0.153	0.157	0.161
P	11.9	12.0	12.1	0.468	0.472	0.476

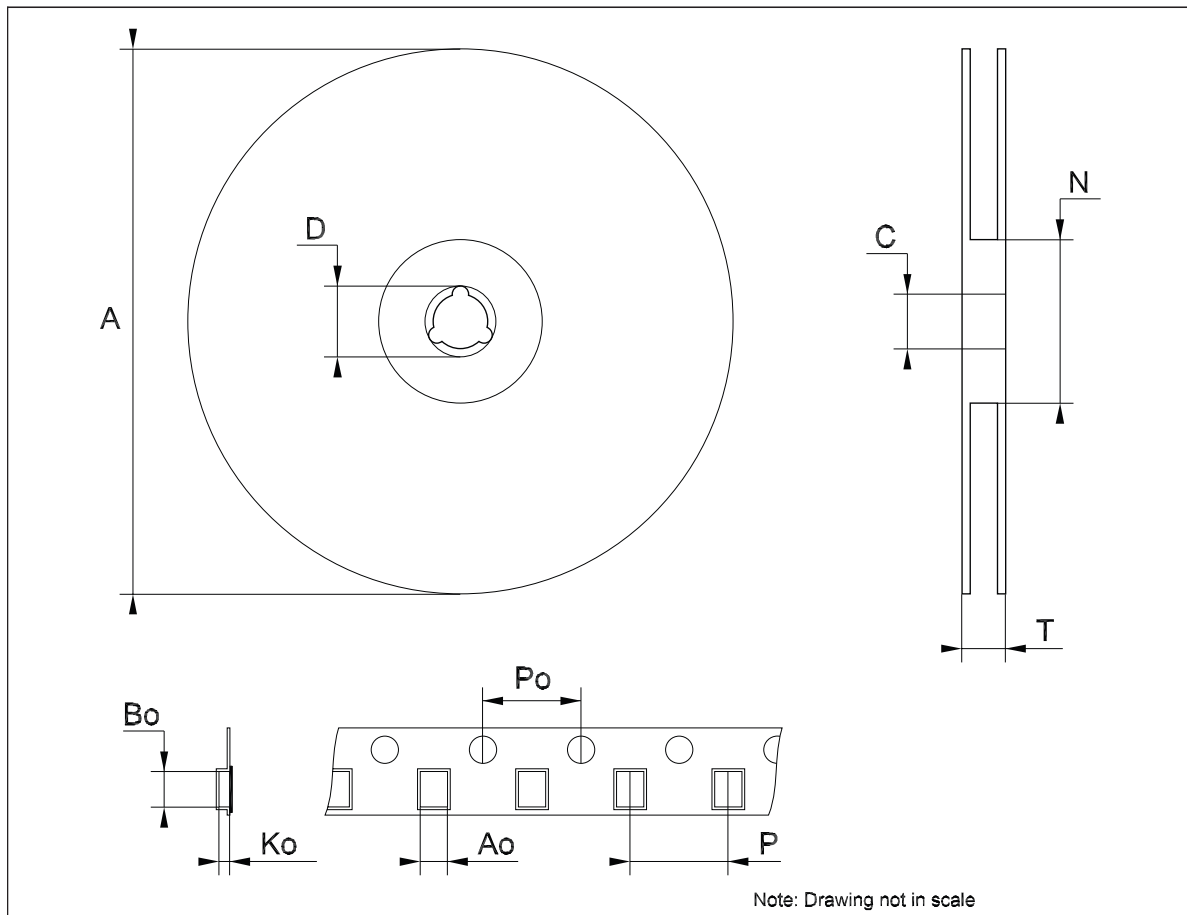

## 9 Revision history

**Table 8. Document revision history**

Date	Revision	Changes
04-Feb-2005	6	Add new package D <sup>2</sup> PAK/A.
18-Sep-2006	7	Order codes has been updated and new template.
31-May-2007	8	Order codes has been updated.
19-Sep-2007	9	Add <a href="#">Table 1</a> in cover page.
20-Feb-2008	10	Modified: <a href="#">Table 1 on page 1</a> .

**Please Read Carefully:**

Information in this document is provided solely in connection with ST products. STMicroelectronics NV and its subsidiaries ("ST") reserve the right to make changes, corrections, modifications or improvements, to this document, and the products and services described herein at any time, without notice.

All ST products are sold pursuant to ST's terms and conditions of sale.

Purchasers are solely responsible for the choice, selection and use of the ST products and services described herein, and ST assumes no liability whatsoever relating to the choice, selection or use of the ST products and services described herein.

No license, express or implied, by estoppel or otherwise, to any intellectual property rights is granted under this document. If any part of this document refers to any third party products or services it shall not be deemed a license grant by ST for the use of such third party products or services, or any intellectual property contained therein or considered as a warranty covering the use in any manner whatsoever of such third party products or services or any intellectual property contained therein.

**UNLESS OTHERWISE SET FORTH IN ST'S TERMS AND CONDITIONS OF SALE ST DISCLAIMS ANY EXPRESS OR IMPLIED WARRANTY WITH RESPECT TO THE USE AND/OR SALE OF ST PRODUCTS INCLUDING WITHOUT LIMITATION IMPLIED WARRANTIES OF MERCHANTABILITY, FITNESS FOR A PARTICULAR PURPOSE (AND THEIR EQUIVALENTS UNDER THE LAWS OF ANY JURISDICTION), OR INFRINGEMENT OF ANY PATENT, COPYRIGHT OR OTHER INTELLECTUAL PROPERTY RIGHT.**

**UNLESS EXPRESSLY APPROVED IN WRITING BY AN AUTHORIZED ST REPRESENTATIVE, ST PRODUCTS ARE NOT RECOMMENDED, AUTHORIZED OR WARRANTED FOR USE IN MILITARY, AIR CRAFT, SPACE, LIFE SAVING, OR LIFE SUSTAINING APPLICATIONS, NOR IN PRODUCTS OR SYSTEMS WHERE FAILURE OR MALFUNCTION MAY RESULT IN PERSONAL INJURY, DEATH, OR SEVERE PROPERTY OR ENVIRONMENTAL DAMAGE. ST PRODUCTS WHICH ARE NOT SPECIFIED AS "AUTOMOTIVE GRADE" MAY ONLY BE USED IN AUTOMOTIVE APPLICATIONS AT USER'S OWN RISK.**

Resale of ST products with provisions different from the statements and/or technical features set forth in this document shall immediately void any warranty granted by ST for the ST product or service described herein and shall not create or extend in any manner whatsoever, any liability of ST.

ST and the ST logo are trademarks or registered trademarks of ST in various countries.

Information in this document supersedes and replaces all information previously supplied.

The ST logo is a registered trademark of STMicroelectronics. All other names are the property of their respective owners.

© 2008 STMicroelectronics - All rights reserved

STMicroelectronics group of companies

Australia - Belgium - Brazil - Canada - China - Czech Republic - Finland - France - Germany - Hong Kong - India - Israel - Italy - Japan - Malaysia - Malta - Morocco - Singapore - Spain - Sweden - Switzerland - United Kingdom - United States of America

[www.st.com](http://www.st.com)