



L4954

QUAD MULTIFUNCTION VOLTAGE REGULATOR FOR CAR RADIO

- 4 REGULATORS
10V (40mA); 8.5V (175mA); 5V (650mA);
5V (100mA) STANDBY
- 10V AND 5V STAND BY REGULATORS ARE
LOW DROPOUT OUTPUTS
- 3 HIGH SIDE DRIVERS:
2A (HSD1), 0.3A (HSD2 & HSD3)
- NO EXTERNAL CHARGE PUMP CAPACI-
TORS ARE REQUIRED
- STAND BY MODE CONTROLLED BY 3 IN-
PUT PINS:
EN1 FOR REG1, REG2, REG3 AND HSD1,
EN2 FOR HSD2, AND EN3 FOR HSD3
- INDIVIDUAL THERMAL SHUTDOWN
- LOGIC OUTPUTS FOR SUPPLY UNDER-
VOLTAGE: (LVWarn, RESET)
- INDEPENDENT CURRENT LIMITING
- OVERVOLTAGE SHUTDOWN
- SHORT CIRCUIT PROTECTION
- LOAD DUMP PROTECTION AND OVERVOL-
TAGE SHUTDOWN

DESCRIPTION

L4954 is a quad output voltage regulator and a

BLOCK DIAGRAM

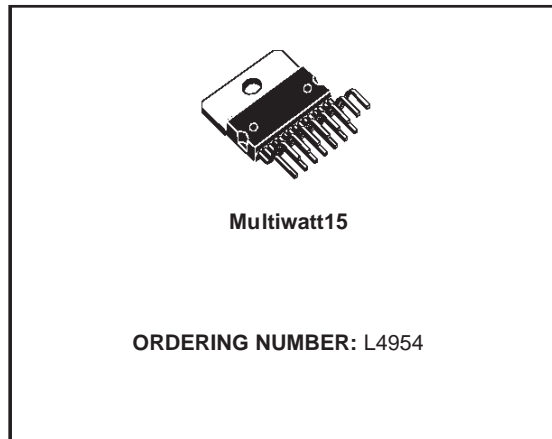
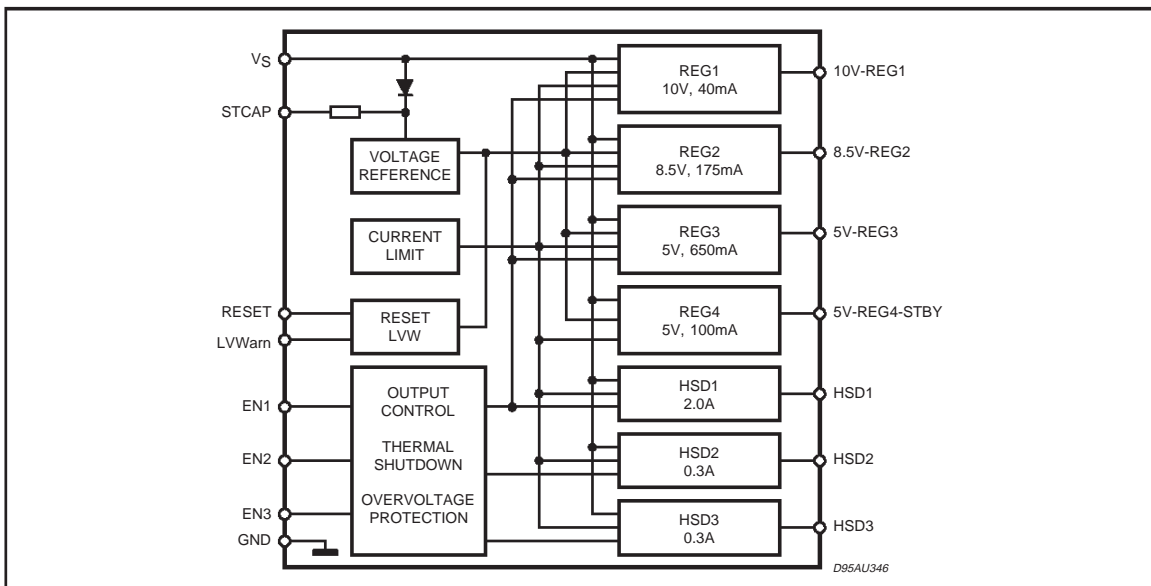

three output high side driver.

The IC includes monitoring circuitry to warn the microprocessor of a low voltage condition: the LVWarn, output, sensing the slow dropping of STCAP pins voltage, gives the microprocessor time to store data.

A RESET output is generated at REG4's decay.

External protection must be provided for reverse battery protection.

L4954

ABSOLUTE MAXIMUM RATINGS

Symbol	Parameter	Value	Unit
V_S	DC Operating Supply Voltage	-0.6 to 26.5	V
V_S	Transient Supply Overvoltages, rise time = 10ms delay time = 115ms	34	V
$V_{S,ovs}$	Overshoot Shutdown	27	V
V_{in}	Input Voltages (EN1, EN2, EN3)	-0.6 to 6.0	V
V_{out}	Output Voltages (LVWarn, RESET)	-0.6 to 6.0	V
T_{op}	Operating Temperature Range	-40 to 85	°C
T_{stg}	Storage Temperature Range	-40 to 150	°C

PIN CONNECTION

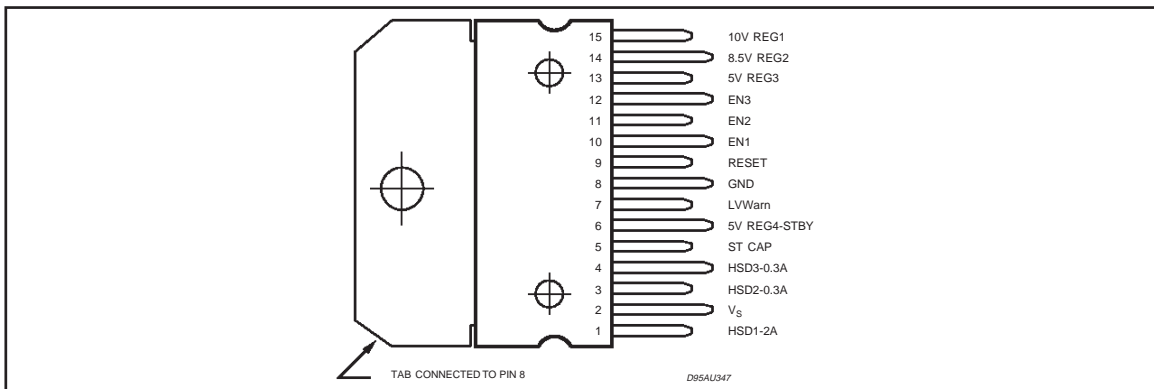

THERMAL DATA

Symbol	Parameter	Value	Unit
$R_{th\ j-case}$	Thermal Resistance Junction-case	2	°C/W

APPLICATION CIRCUIT

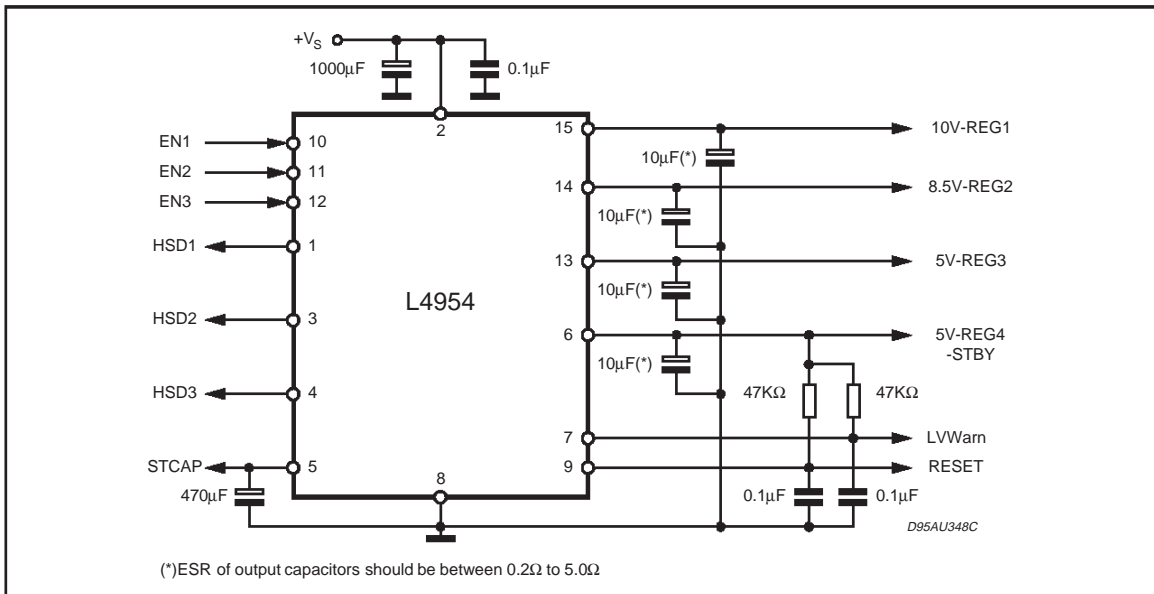

ELECTRICAL CHARACTERISTICS (Refer to the application circuit, $V_S = 14.4V$; $T_{amb} = 25^\circ C$; $I_{OUT10} = 5mA$; $I_{OUT8.5} = 5mA$; $I_{OUT5} = 5mA$; $I_{OUT5\ ST-BY} = 0.5mA$; $R_{HSD1} = 16\Omega$, $R_{HSD2,3} = 107\Omega$, unless otherwise specified.)

Symbol	Parameter	Test Condition	Min.	Typ.	Max.	Unit
V_S	Operating Supply Voltage		11		16	V
I_q	Maximum Quiescent Current	$I_{OUT10} = 40mA$; $I_{OUT8.5} = 175mA$; $I_{OUT5} = 650mA$; $I_{OUT5\ ST-BY} = 100mA$; $R_{HSD1} = 8\Omega$; $R_{HSD2,3} = 53\Omega$		10		mA
$I_{q,ST-BY}$	Standby Quiescent Current	EN1, EN2, EN3 = 0 $I_{OUT5, ST-BY} = 50mA$;		420		μA
		EN1, EN2, EN3 = 0 $I_{OUT5, ST-BY} = 2mA$;		300		μA
V_{ENL}	EN1, EN2, EN3 Input Low Voltage		0		0.8	V
V_{ENH}	EN1, EN2, EN3 Input High Voltage (Outputs Active)		2		5	V
10V / 40mA REG 1 OUTPUT						
V_{OUT10}	Output Voltage	$I_{OUT10} = 40mA$		10		V
ΔV_{line}	Line Regulation	$V_S = 11$ to 26V		2		mV
ΔV_{load}	Load Regulation	$I_{out10} = 5$ to 40mA		2		mV
$V_{DROPOUT}$	Dropout Voltage	$V_S = V_{OUT10} + 0.1V$ $I_{out10} = 5mA$		100	200	mV
		$V_S = V_{OUT10} + 0.5V$ $I_{out10} = 40mA$		500	600	mV
I_{q1}	Reg 1 Quiescent Current	$I_{OUT10} = 5mA$		7		mA
		$I_{OUT10} = 40mA$		7		mA
I_{lim1}	Current Limit			100		mA
SVR_1	Reg 1 Supply Voltage Rejection	$f = 0.12$ to 10KHz; $I_{OUT10} = 25mA$; $V_{RIP} = 1V_{pp}$		55		dB
8.5V / 175mA REG 2 OUTPUT						
$V_{OUT8.5}$	Output Voltage	$I_{OUT8.5} = 175mA$		8.5		V
ΔV_{line}	Line Regulation	$V_S = 11$ to 26V		2		mV
ΔV_{load}	Load Regulation	$I_{out8.5} = 5$ to 175mA		10		mV
$V_{DROPOUT}$	Dropout Voltage	$V_S = V_{OUT8.5} + 0.3V$ $I_{out8.5} = 5mA$		300	400	mV
		$V_S = V_{OUT8.5} + 1V$ $I_{out8.5} = 175mA$		1	1.1	V
I_{q2}	Reg 2 Quiescent Current	$I_{OUT8.5} = 5mA$		7		mA
		$I_{OUT8.5} = 175mA$		7		mA
I_{lim2}	Current Limit			300		mA
SVR_2	Reg 1 Supply Voltage Rejection	$f = 0.12$ to 10KHz; $I_{OUT8.5} = 100mA$; $V_{RIP} = 1V_{pp}$		55		dB

ELECTRICAL CHARACTERISTICS (Continued)

Symbol	Parameter	Test Condition	Min.	Typ.	Max.	Unit
5V / 650mA REG 3 OUTPUT						
V_{OUT5}	Output Voltage	$I_{OUT5} = 650\text{mA}$		5		V
ΔV_{line}	Line Regulation	$V_S = 7 \text{ to } 26\text{V}$		2		mV
ΔV_{load}	Load Regulation	$I_{out5} = 5 \text{ to } 650\text{mA}$		9		mV
$V_{DROPOUT}$	Dropout Voltage	$V_S = V_{OUT5} + 0.3\text{V}$ $I_{out5} = 5\text{mA}$		300	400	mV
		$V_S = V_{OUT5} + 1\text{V}$ $I_{out5} = 650\text{mA}$		1	1.1	V
I_{q3}	Reg 3 Quiescent Current	$I_{OUT5} = 5\text{mA}$		7		mA
		$I_{OUT5} = 650\text{mA}$		7		mA
I_{lim3}	Current Limit			1.25		A
SVR_3	Reg 3 Supply Voltage Rejection	$f = 0.12 \text{ to } 10\text{KHz}$; $I_{OUT5} = 325\text{mA}$; $V_{RIP} = 1V_{pp}$		55		dB
5V / 100mA STAND-BY REG 4 OUTPUT						
$V_{OUT5STBY}$	Output Voltage	$I_{OUT5STBY} = 100\text{mA}$		5		V
ΔV_{line}	Line Regulation	$V_S = 7 \text{ to } 26\text{V}$		0.8		mV
ΔV_{load}	Load Regulation	$I_{out} = 0.5 \text{ to } 100\text{mA}$		3.5		mV
$V_{DROPOUT}$	Dropout Voltage	$V_S = V_{REG5STBY} + 0.1\text{V}$ $I_{out5STBY} = 5\text{mA}$		100	200	mV
		$V_S = V_{REG5STBY} + 0.5\text{V}$ $I_{out5STBY} = 100\text{mA}$		500	600	mV
I_{q4}	Reg 4 Quiescent Current	$I_{OUT5STBY} = 2\text{mA}$		0.25		mA
		$I_{OUT5STBY} = 100\text{mA}$		0.35		mA
I_{lim4}	Current Limit			190		mA
SVR_4	Reg 4 Supply Voltage Rejection	$f = 0.12 \text{ to } 10\text{KHz}$ $I_{out5STBY} = 50\text{mA}$; $V_{RIP} = 1V_{pp}$		55		dB
2A HSD1						
$V_{sat,peak}$	Maximum Output Current Saturation Voltage	$R_{HSD1} = 8\Omega$		600		mV
I_q	Quiescent Current			9		mA
I_{lim}	Current Limit	$R_{HSD1} = 0.5\Omega$		3.5		A
I_{leak1}	Output Leakage Current	All driver outputs are off		20		μA
0.3A HSD2 & HSD3						
V_{sat}	Maximum Output Current Saturation Voltage	$R_{HSD2,3} = 53\Omega$		150		mV
I_q	Quiescent Current			1.5		mA
I_{lim}	Current Limit	$R_{HSD2,3} = 0.5\Omega$		500		mA
$I_{leak2,3}$	Output Leakage Current	All driver outputs are off		10		μA

ELECTRICAL CHARACTERISTICS (Continued)

Symbol	Parameter	Test Condition	Min.	Typ.	Max.	Unit
LVWARN OUTPUT						
TH _{LVW}	LVW Threshold on STCAP			7.5		V
V _{LVW}	LVW Output Voltage	STCAP < 7.5V; V _{IL} = "0"	0		0.4	V
		STCAP > 7.5V V _{IH} = "1"	2.75		5	V
t _{rise}	LVW Output Rise Time	C _{LVW} = 0.1μF		3.9		ms
t _{fall}	LVW Output Fall Time	C _{LVW} = 0.1μF		12.6		μs
RESET OUTPUT						
TH _{RES}	Reset Threshold on Reg 4			4.5		V
V _{RES}	Reset Output Voltage	Set V _S so that V _{OUT5STBY} < 4.5V; V _{IL} = "0"	0		0.4	V
		Set V _S so that V _{OUT5STBY} is not less than normal REG4 output voltage; V _{IH} = "1"	2.75		5	V
t _{rise}	Reset Output Rise Time	C _{RESET} = 0.1μF		4.5		ms
t _{fall}	Reset Output Fall Time	C _{RESET} = 0.1μF		37		μs

FUNCTIONAL DESCRIPTION

The L4954 includes a monitoring circuit to warn the microprocessor if a low voltage or no voltage condition is occurring.

When the voltage on the STCAP pin drops below 7.5V (typ), the LVW output will go low. This tells the microprocessor to stop executing code and save vital information. The reset output will go low when REG4 (5V-STBY) drops below (V_{REG4} - 250mV) or 4.75V is minimum value. The RESET output doesn't go above 0.4V until REG4 has gone back above 4.75V (min).

Any spike will tell the microprocessor to start operating. Once the STCAP line passes 7.5V (typ), the LVWarn output will also return to high state. The STCAP pin acts like a delay circuit. Due to the large capacitor (470μF), the STCAP pin al-

lows the battery voltage to decay slowly giving the microprocessor time to store data.

Also, during short low voltage or negative voltage conditions, the STCAP pin protects the 5V STBY output from dropping below the RESET and LVW trip points. The four outputs are expected to follow the battery voltage down to 11V for REG1, 9V for REG2, 6V for REG3 and REG4.

The L4954 has a STBY mode to keep the microprocessor and memories alive during an ignition off conditions. The EN1 input pin is controlled by the microprocessor. A high on the EN1 input turns on REG1, REG2, REG3, and HSD1. A Low on EN1 places the part in stand-by mode with REG4 on. The High side driver outputs HSD2 and HSD3 are controlled by EN2 and EN3 respectively: a Low on the control input turns the corresponding high side driver off.

TIMING DIAGRAM

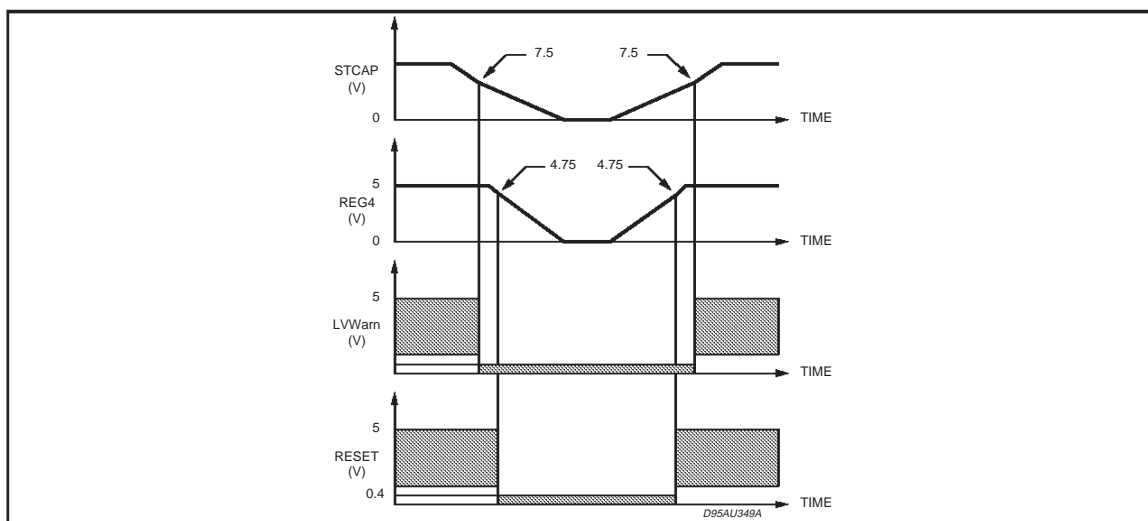

L4954

DIM.	mm			inch		
	MIN.	TYP.	MAX.	MIN.	TYP.	MAX.
A			5			0.197
B			2.65			0.104
C			1.6			0.063
D		1			0.039	
E	0.49		0.55	0.019		0.022
F	0.66		0.75	0.026		0.030
G	1.02	1.27	1.52	0.040	0.050	0.060
G1	17.53	17.78	18.03	0.690	0.700	0.710
H1	19.6			0.772		
H2			20.2			0.795
L	21.9	22.2	22.5	0.862	0.874	0.886
L1	21.7	22.1	22.5	0.854	0.870	0.886
L2	17.65		18.1	0.695		0.713
L3	17.25	17.5	17.75	0.679	0.689	0.699
L4	10.3	10.7	10.9	0.406	0.421	0.429
L7	2.65		2.9	0.104		0.114
M	4.25	4.55	4.85	0.167	0.179	0.191
M1	4.63	5.08	5.53	0.182	0.200	0.218
S	1.9		2.6	0.075		0.102
S1	1.9		2.6	0.075		0.102
Dia1	3.65		3.85	0.144		0.152

OUTLINE AND MECHANICAL DATA

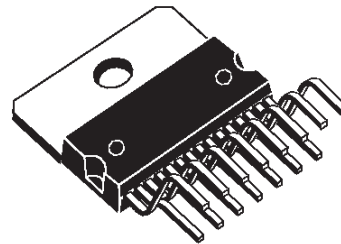

Multiwatt15 V

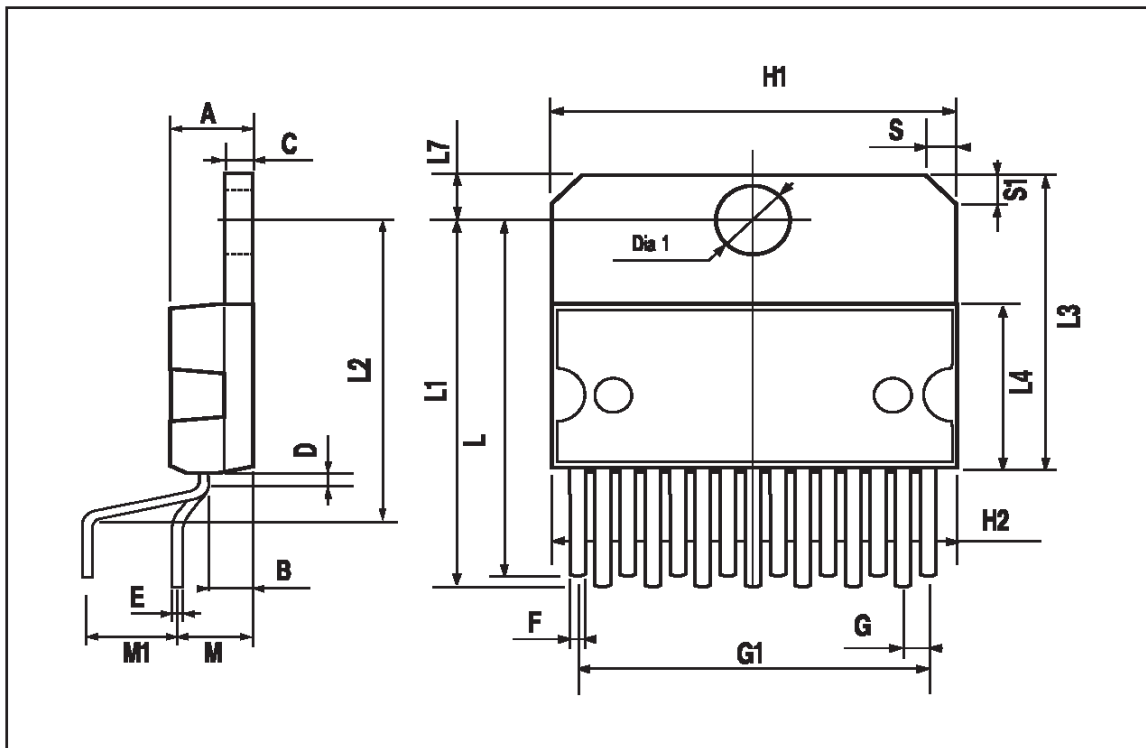

Information furnished is believed to be accurate and reliable. However, STMicroelectronics assumes no responsibility for the consequences of use of such information nor for any infringement of patents or other rights of third parties which may result from its use. No license is granted by implication or otherwise under any patent or patent rights of STMicroelectronics. Specification mentioned in this publication are subject to change without notice. This publication supersedes and replaces all information previously supplied. STMicroelectronics products are not authorized for use as critical components in life support devices or systems without express written approval of STMicroelectronics.

The ST logo is a registered trademark of STMicroelectronics
© 2000 STMicroelectronics – Printed in Italy – All Rights Reserved
STMicroelectronics GROUP OF COMPANIES

Australia - Brazil - China - Finland - France - Germany - Hong Kong - India - Italy - Japan - Malaysia - Malta - Morocco -
Singapore - Spain - Sweden - Switzerland - United Kingdom - U.S.A.

<http://www.st.com>

