

Large Current External FET Controller Type Switching Regulators

Single-output Step-up, High-efficiency Switching Regulator (Controller Type)



BD9763FVM

●Description

BD9763FVM is a 1-channel high efficiency step-up switching regulator.

It is possible to choose small application space due to its high-speed operation (Max switching frequency 1.2MHz)

●Features

- 1) Build-in under voltage lock out circuit.
- 2) High accuracy reference voltage ($2.5V \pm 1.0\%$)
- 3) Establish maximum duty cycle internally.
- 4) CTL/SS terminal for both stand-by and soft-start function. (Soft-start time can be set by external capacitor)
- 5) MSOP8 thin and small package.

●Applications

Single-lens reflex cameras, digital video cameras, liquid crystal modules, DVD drive.

●Absolute Maximum Ratings (Ta=25°C)

Parameter	Symbol	Range	Unit
Supply voltage	Vcc	10	V
Storage temperature range	Tstg	-55 to +150	°C
Power dissipation	Pd	587 *	mW
Junction temperature	Tjmax	+150	°C

* IC mounted on a PCB board (70mm x 70mm x 1.6mm, glass epoxy).

Reduced by 4.7mW for each increase in Ta of 1°C over 25°C.

●Recommended Operating Conditions

Parameter	Symbol	Range			Unit
		MIN	TYP	MAX	
Supply voltage	Vcc	4	7	9	V
Oscillating frequency	fosc	100	—	1200	kHz
Operating temperature range	Topr	-40	—	+85	°C

● Electrical characteristics (Unless otherwise specified, Ta=25°C, Vcc=7.0V)

Parameter	Symbol	Limits			Unit	Condition
		MIN	TYP	MAX		
【Oscillator】						
Oscillating frequency	fosc	522	600	678	KHz	R _{RT} =24kΩ
Frequency tolerance	FDV	-5	0	5	%	V _{CC} =4 to 9V
Swing voltage	V _{pptr}	—	0.5	—	V	
【Stand-by, Soft start】						
CTL/SS pin source current	ISS	-1.90	-1.00	-0.55	μA	V _{CTL/SS} =1.5V
CTL/SS pin clamp voltage	VSS	2.2	2.4	2.6	V	
CTL threshold voltage	VCTLTH	1.2	1.3	1.4	V	
【PWM comparator】						
0% threshold voltage	D0	1.5	1.6	1.7	V	
Maximum duty cycle	DMAX	80	90	99.5	%	
【Error amplifier】						
Threshold voltage	VIN	0.98	1.00	1.02	V	
Band width	BW	—	3.0	—	MHz	AV=0dB
Voltage gain	Av	—	70	—	dB	
Input bias current	IIB	-150	-70	—	nA	
Maximum output voltage	VCH	2.3	2.4	2.6	V	
Minimum output current	VCL	—	0.03	0.20	V	
Output source current	IOI	-3.1	-1.6	-1.0	mA	V _{FB} =1.0V
Output sink current	IOO	12	50	125	mA	V _{FB} =1.0V
【Reference voltage】						
Output voltage	VREF	2.475	2.500	2.525	V	I _{VREF} =0mA
Load regulation	ΔVREF _{lo}	-	-	10	mV	I _{VREF} =0 to -1mA
Output short current	IVREF	-45	-16	-1	mA	
【Whole device】						
Stand-by current	ICCS	420	610	960	μA	
Circuit current	ICCA	3.4	5.0	7.8	mA	No load
【Output】						
ON resistance	RON	0.9	2.5	8.0	Ω	
Output rise/fall time	Tr/Tf	—	20	—	nsec	C _{out} =1000pF
Output source current	IOUTSO	—	-0.80	—	A	Ta=-40 to 85°C, VCC=4 to 9V, OUT=0V, rush current
Output sink current	IOUTSI	—	0.85	—	A	Ta=-40 to 85°C, VCC=4 to 9V, OUT=VCC, rush current
【Under voltage lock out】						
Threshold voltage	VUT	3.7	3.8	3.9	V	Vcc sweep down
Hysteresis width	VUThy	0.05	0.10	0.15	V	

● Reference data (Unless otherwise specified, $T_a=25^\circ\text{C}$)

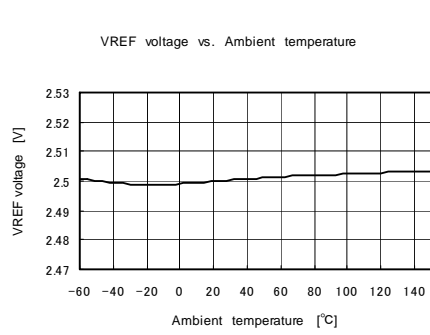

Fig.1 VREF voltage – Ambient temperature

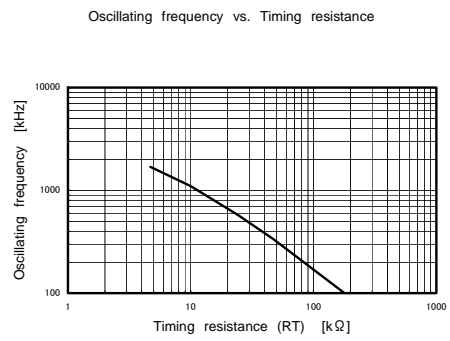

Fig.2 Oscillating frequency – Timing resistance (RRT)

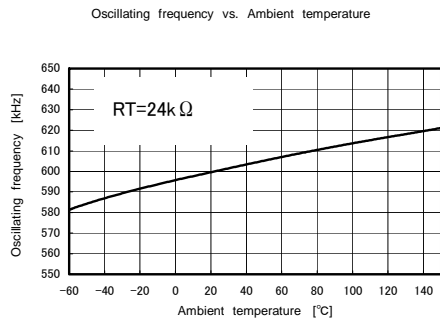

Fig.3 Oscillating frequency – Ambient temperature
(RT=24kΩ)

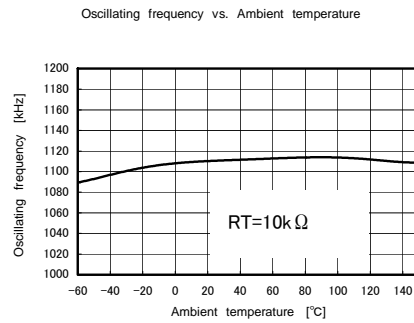
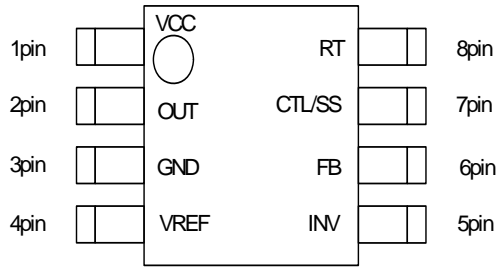
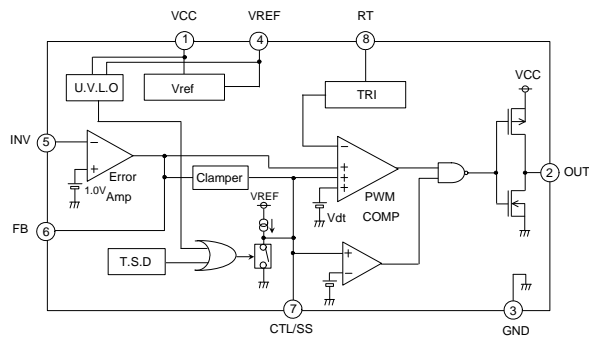

Fig.4 Oscillating frequency – Ambient temperature
(RT=10kΩ)

● Pin configuration



● Block diagram



● Pin number · Pin name

Pin No.	Pin name	Function
1	VCC	Power supply
2	OUT	FET driver output
3	GND	Ground
4	VREF	Reference voltage ($2.5V \pm 1\%$) output
5	INV	Inverting input of error amplifier
6	FB	Output of error amplifier
7	CTL/SS	Stand-by switch/Soft start capacitor connecting pin
8	RT	Timing resistor connecting pin

●Block description

· VOLTAGE REFERENCE(VREF) BLOCK

This voltage reference block generates 2.5V internal reference voltage.

· OSCILLATOR BLOCK

Oscillator block sets the oscillating frequency adjusted by an external resistance in RT pin. The oscillating frequency can be set within a range of 100~1200kHz.. (See the description of how to set the frequency on page6.)

· PWM COMP

The PWM comparator transforms the voltage outputted from error amp to PWM waveform and outputs to FET driver. The maximum duty cycle is limited up to 90%.

· ERROR AMP BLOCK

The error amp block detects the output voltage from the INV pin, amplifies the difference between the detected voltage and the reference voltage, and outputs it to FB pin. The reference voltage is $1V \pm 2\%$.

· PROTECTION CIRCUIT BLOCK

The under voltage lock out circuit is activated to shut down the whole circuit when the VCC voltage is up to 3.8V. When the thermal shutdown circuit detects abnormal heating of the chip (150°C), the output becomes off. And the output turns back on when the chip temperature goes down to a specific level.

●Application example

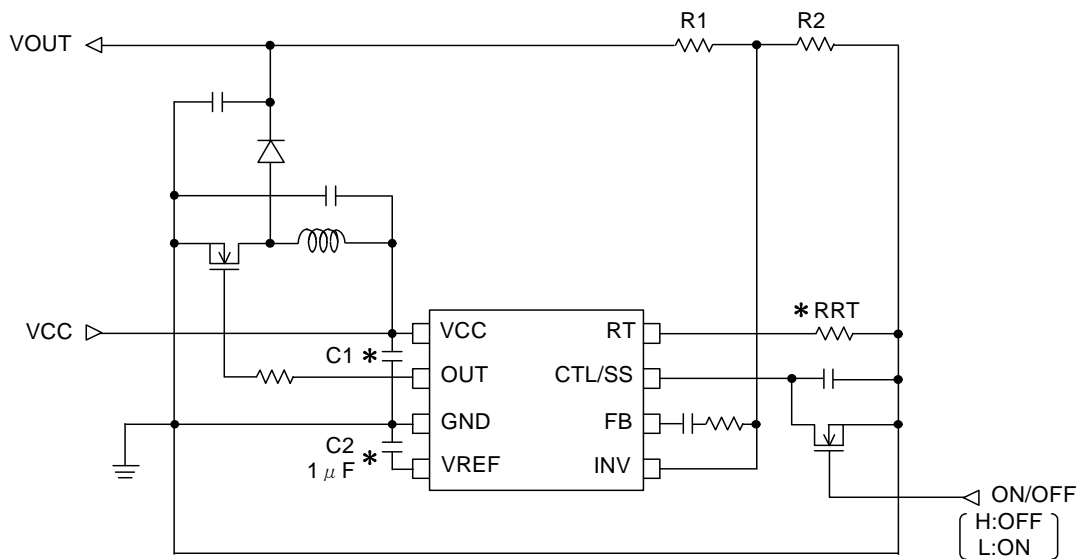

● Selecting application components

(1) Output inductor

It is recommended to use an inductor which satisfies the following rating current (the following value of current), and also has low DCR. The shield type inductor is preferable.

$$I_{peak} = I_o \cdot (V_o / V_{IN}) / \eta + V_{IN} \cdot (V_{OUT} - V_{IN}) / (2 \cdot V_{OUT} \cdot L \cdot f) \quad [A]$$

[I_o : Output V_o : Output voltage V_{IN} : Input voltage η : Efficiency L : Inductance f : Oscillating frequency]

(2) Output capacitor

It is recommended to use the output capacitor which has the enough margin to maximum rating for output voltage and low fluctuation for temperature. The ripple voltage of the output is influenced by ESR of the output capacitor.

$$V_{ripple} = V_{IN} \cdot (V_{OUT} - V_{IN}) / (V_{OUT} \cdot L \cdot f) \cdot ESR \quad [V]$$

$$(f \gg 1 / (2\pi \sqrt{LC})) \cdot V_o / V_{IN}$$

[I_o : Output V_o : Output voltage V_{IN} : Input voltage η : Efficiency L : Inductance
 C : Output capacitor f : Oscillating frequency]

(3) FET

It is recommended to use FETs which satisfy followings and have small Ciss or Qg and ON resistance.

D-S Voltage : Over (Output voltage + Vf of Di)

G-S Voltage : Over input voltage

D-S Current : Over Ipeak at the section of output inductor

(4) Diode

It is recommended to use a schottky diode which satisfies followings and has low forward voltage drop and high switching speed.

Maximum current : Over maximum output current

Direct reverse voltage : Over output voltage

※ Please provide sufficient margin in the choice of external components by factoring into the worst case characteristics and temperature range.

(5) Setting the oscillator frequency

Refer to Fig.5 and determine Timing resistor (RRT) when setting the oscillating frequency.

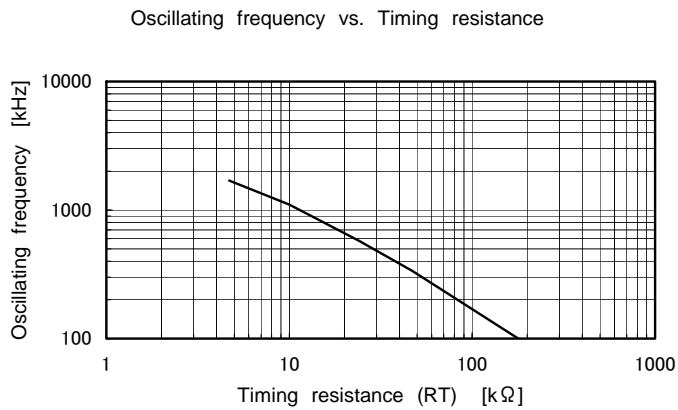

Fig.5 Oscillating frequency – Timing resistance (RRT)

(6) Setting the output voltage

The output voltage is calculated by the following equation.

$$V_o = V_{IN} V_{th} \cdot (R_1 + R_2) / R_2 \quad [V]$$

R₁, R₂ : Resistor divider network

V_{INth} : Error amp threshold voltage (typ. 1V)

(but $V_o < V_{IN} \cdot 5$ because of MAXDUTY Min=80%)

(7) CTL/SS setting the soft start time

The time after CTL/SS is released before the output voltage starts to rise.

$$t(\text{start}) = C_{CTL} \cdot (V_{Do} - V_{off}) / I_{ss} \quad [S] \quad \text{approximated equation}$$

The time after the output voltage starts up before it reaches the specified output level.

$$t(\text{soft}) = C_{CTL} \cdot (V_{DUTY} - V_{Do}) / I_{ss} \quad [S] \quad \text{approximated equation}$$

$$V_{DUTY} = V_{Do} + 0.5 \cdot (1 - V_{IN} / V_{OUT}) \quad [V]$$

C_{CTL} : CTL/SS–GND capacitance V_{do} : 0% duty threshold (Typ 1.6V) V_{off} : Output off CTL/SS voltage

I_{ss} : CTL/SS charge current (Typ 1uA) V_{DUTY} : stabilization operating ON duty.

● Timing chart

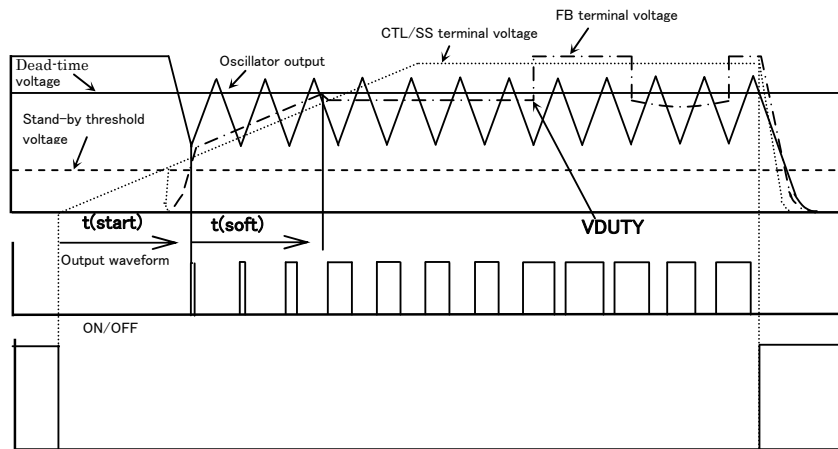

● Recommended board patterns

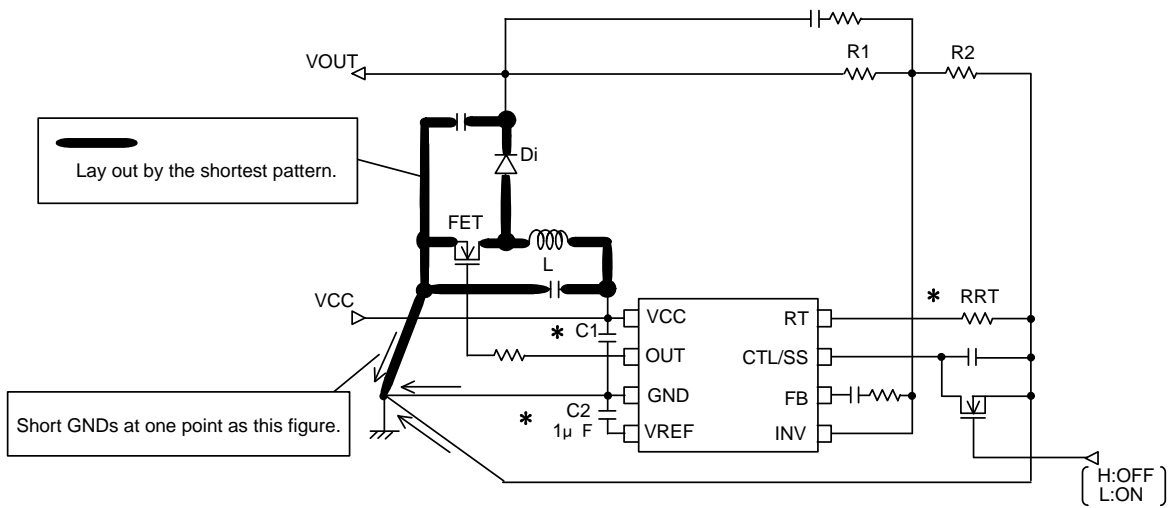

* Place these parts with attention about patterns shown in following Fig.7

Fig.6

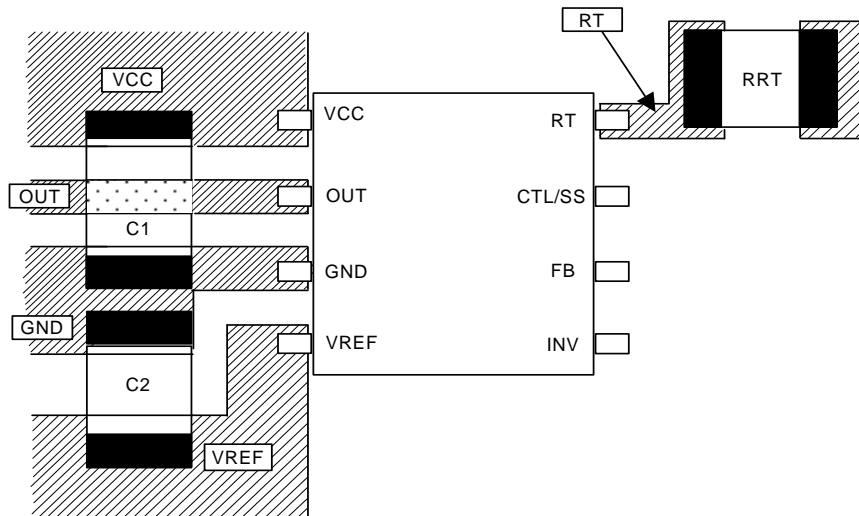

C1 : Capacitor terminals have to be close enough to terminals of VCC and GND.
It is safe to pass OUT signal line under C1.

C2 : Capacitor terminals have to be close enough to terminals of VREF and GND.

R1 : Pattern area has to be small enough to reduce parasitic capacitance of RT terminal.

Fig.7 Recommended board patterns

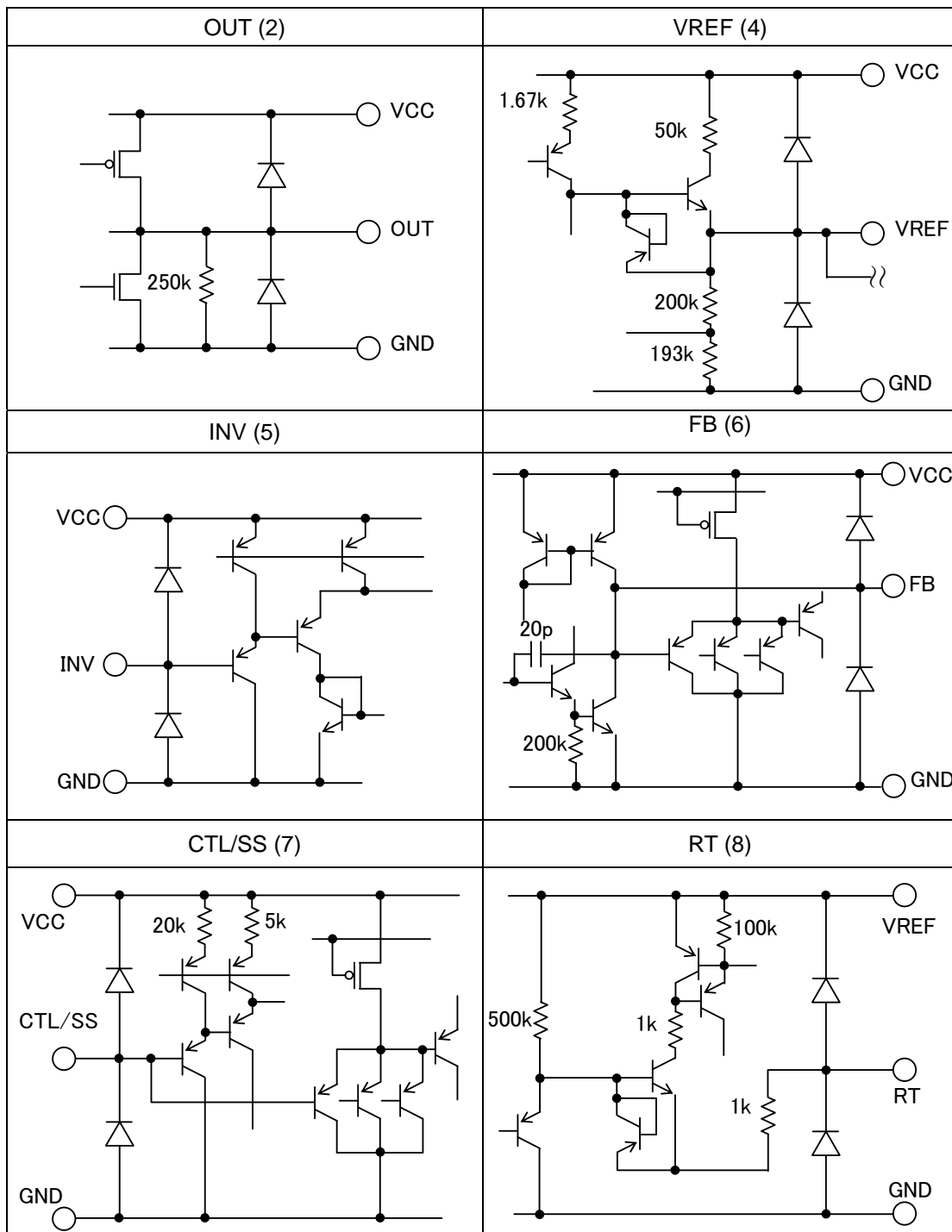

Fig.11

● Operation Notes

(1) Absolute maximum ratings

Use of the IC in excess of absolute maximum ratings such as the applied voltage or operating temperature range may result in IC deterioration or damage. Assumptions should not be made regarding the state of the IC (short mode or open mode) when such damage is suffered. A physical safety measure such as fuse should be implemented when use of the IC in a special mode where the absolute maximum ratings may be exceeded is anticipated.

(2) GND potential

Ensure a minimum GND pin potential in all operating conditions. In addition, ensure that no pins other than the GND pin carry a voltage lower than or equal to the GND pin, including during actual transient phenomena.

(3) Thermal design

Use a thermal design that allows for a sufficient margin in light of the power dissipation (P_d) in actual operating conditions.

(4) Inter-pin shorts and mounting errors

Use caution when orienting and positioning the IC for mounting on printed circuit boards. Improper mounting may result in damage to the IC. Shorts between output pins or between output pins and the power supply and GND pin caused by the presence of a foreign object may result in damage to the IC.

(5) Operation in a strong electromagnetic field

Use caution when using the IC in the presence of a strong electromagnetic field as doing so may cause the IC to malfunction.

(6) Thermal shutdown circuit (TSD circuit)

This IC incorporates a built-in thermal shutdown circuit (TSD circuit). The TSD circuit is designed only to shut the IC off to prevent runaway thermal operation.

Do not continue to use the IC after operating this circuit or use the IC in an environment where the operation of the thermal shutdown circuit is assumed.

(7) Testing on application boards

When testing the IC on an application board, connecting a capacitor to pin with low impedance subjects the IC to stress. Always discharge capacitors after each process or step. Ground the IC during assembly steps as an antistatic measure, and use similar caution when transporting or storing the IC. Always turn the IC's power supply off before connecting it to or removing it from a jig or fixture in the inspection process.

(8) Common impedance

Power supply and ground wiring should reflect consideration of the need to lower common impedance and minimize ripple as much as possible (by making wiring as short and thick as possible or rejecting ripple by incorporating inductance and capacitance).

(9) Applications with modes that reverse VCC and pin potentials may cause damage to internal IC circuits.

For example, such damage might occur when VCC is shorted with the GND pin while an external capacitor is charged. It is recommended to insert a diode for preventing back current flow in series with VCC or bypass diodes between VCC and each pin.

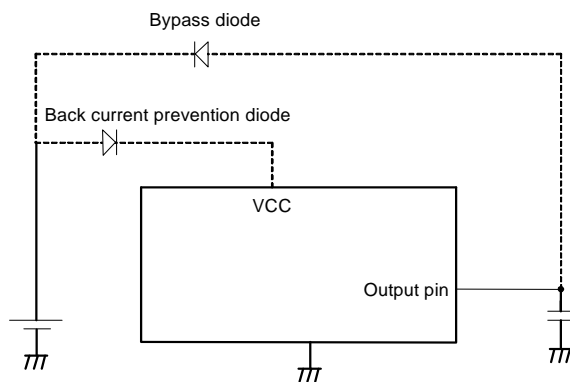

(10) Timing resistor

Timing resistor connected between RT and GND, has to be placed near RT terminal (8pin). And pattern has to be short enough.

(11) IC pin input

This monolithic IC contains P + isolation and PCB layers between adjacent elements in order to keep them isolated. P/N junctions are formed at the intersection of these P layers with the N layers of other elements to create a variety of parasitic elements.

For example, when a resistor and transistor are connected to pins as shown in Fig.13,

- the P/N junction functions as a parasitic diode when $GND > (Pin A)$ for the resistor or $GND > (Pin B)$ for the transistor (NPN).
- Similarly, when $GND > (Pin B)$ for the transistor (NPN), the parasitic diode described above combines with the N layer of other adjacent elements to operate as a parasitic NPN transistor.

The formation of parasitic elements as a result of the relationships of the potentials of different pins is an inevitable result of the IC's architecture. The operation of parasitic elements can cause interference with circuit operation as well as IC malfunction and damage. For these reasons, it is necessary to use caution so that the IC is not used in a way that will trigger the operation of parasitic elements, such as by the application of voltage lower than the GND (PCB) voltage to input and output pins.

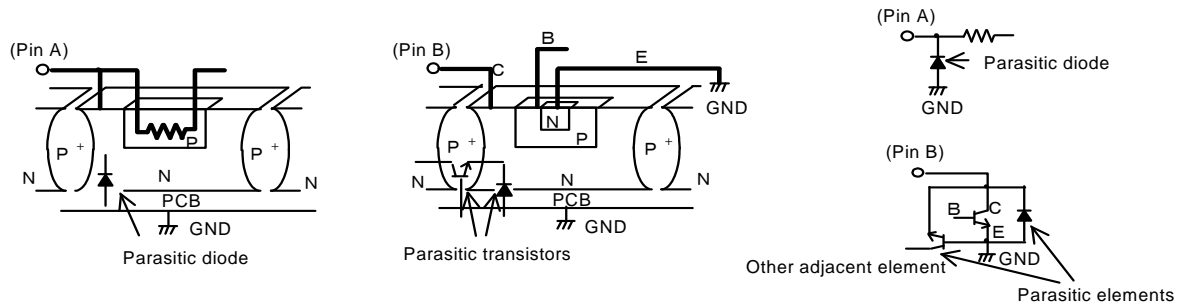

● Power Dissipation Reduction

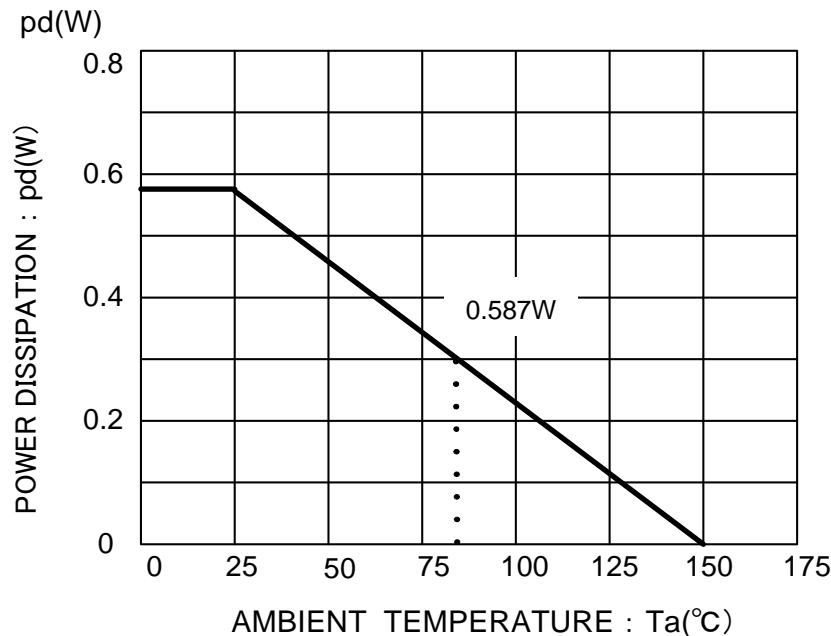

IC mounted on a ROHM standard board (70mm x 70mm x 1.6mm, glass epoxy)

● Selecting a Model Name When Ordering

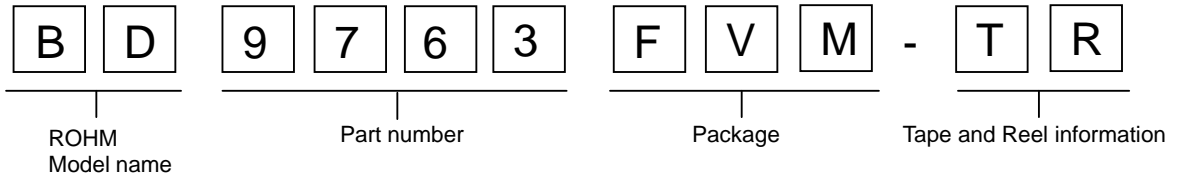

MSOP8

<Dimension>

(Unit:mm)

<Tape and Reel information>

Tape	Embossed carrier tape
Quantity	3000pcs
Direction of feed	TR (The direction is the 1pin of product is at the upper light when you hold reel on the left hand and you pull out the tape on the right hand)

Reel 1Pin Direction of feed →

※When you order , please order in times the amount of package quantity.

Notes

- No technical content pages of this document may be reproduced in any form or transmitted by any means without prior permission of ROHM CO.,LTD.
- The contents described herein are subject to change without notice. The specifications for the product described in this document are for reference only. Upon actual use, therefore, please request that specifications to be separately delivered.
- Application circuit diagrams and circuit constants contained herein are shown as examples of standard use and operation. Please pay careful attention to the peripheral conditions when designing circuits and deciding upon circuit constants in the set.
- Any data, including, but not limited to application circuit diagrams information, described herein are intended only as illustrations of such devices and not as the specifications for such devices. ROHM CO.,LTD. disclaims any warranty that any use of such devices shall be free from infringement of any third party's intellectual property rights or other proprietary rights, and further, assumes no liability of whatsoever nature in the event of any such infringement, or arising from or connected with or related to the use of such devices.
- Upon the sale of any such devices, other than for buyer's right to use such devices itself, resell or otherwise dispose of the same, no express or implied right or license to practice or commercially exploit any intellectual property rights or other proprietary rights owned or controlled by
- ROHM CO., LTD. is granted to any such buyer.
- Products listed in this document are no antiradiation design.

The products listed in this document are designed to be used with ordinary electronic equipment or devices (such as audio visual equipment, office-automation equipment, communications devices, electrical appliances and electronic toys).

Should you intend to use these products with equipment or devices which require an extremely high level of reliability and the malfunction of which would directly endanger human life (such as medical instruments, transportation equipment, aerospace machinery, nuclear-reactor controllers, fuel controllers and other safety devices), please be sure to consult with our sales representative in advance.

It is our top priority to supply products with the utmost quality and reliability. However, there is always a chance of failure due to unexpected factors. Therefore, please take into account the derating characteristics and allow for sufficient safety features, such as extra margin, anti-flammability, and fail-safe measures when designing in order to prevent possible accidents that may result in bodily harm or fire caused by component failure. ROHM cannot be held responsible for any damages arising from the use of the products under conditions out of the range of the specifications or due to non-compliance with the NOTES specified in this catalog.

Thank you for your accessing to ROHM product informations.

More detail product informations and catalogs are available, please contact your nearest sales office.

ROHM Customer Support System

THE AMERICAS / EUROPE / ASIA / JAPAN

www.rohm.com

Contact us : webmaster@rohm.co.jp