

CS2842A, CS3842A, CS2843A, CS3843A



ON Semiconductor™

<http://onsemi.com>

Off-Line Current Mode PWM Control Circuit with Undervoltage Lockout

The CS284XA, CS384XA provides all the necessary features to implement off-line fixed frequency current-mode control with a minimum number of external components.

The CS384XA family incorporates a new precision temperature-controlled oscillator with an internally trimmed discharge current to minimize variations in frequency. A precision duty-cycle clamp eliminates the need for an external oscillator when a 50% duty-cycle is used. Duty-cycles greater than 50% are also possible. On board logic ensures that V_{REF} is stabilized before the output stage is enabled. Ion implant resistors provide tighter control of undervoltage lockout.

Other features include low startup current, pulse-by-pulse current limiting, and a high-current totem pole output for driving capacitive loads, such as the gate of power MOSFET. The output is LOW in the off state, consistent with N-channel devices.

The CS384XA series of current-mode control ICs are available in 8 and 14 lead packages for surface mount (SO) applications as well as 8 lead PDIP packages.

Features

- Optimized for Off-line Control
- Internally Trimmed Temperature Compensated Oscillator
- Maximum Duty-Cycle Clamp
- V_{REF} Stabilized Before Output Stage is Enabled
- Low Startup Current
- Pulse-By-Pulse Current Limiting
- Improved Undervoltage Lockout
- Double Pulse Suppression
- 1.0% Trimmed Bandgap Reference
- High Current Totem Pole Output

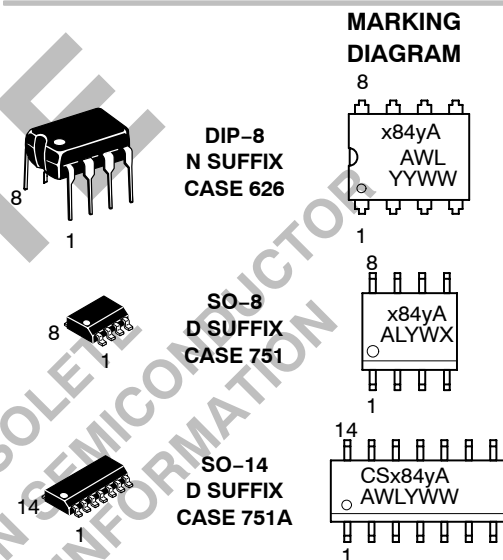

x = 2 or 3
 y = 2 or 3
 A = Assembly Location
 WL, L = Wafer Lot
 YY, Y = Year
 WW, W = Work Week

ORDERING INFORMATION

See detailed ordering and shipping information in the package dimensions section on page 8 of this data sheet.

CS2842A, CS3842A, CS2843A, CS3843A

PIN CONNECTIONS

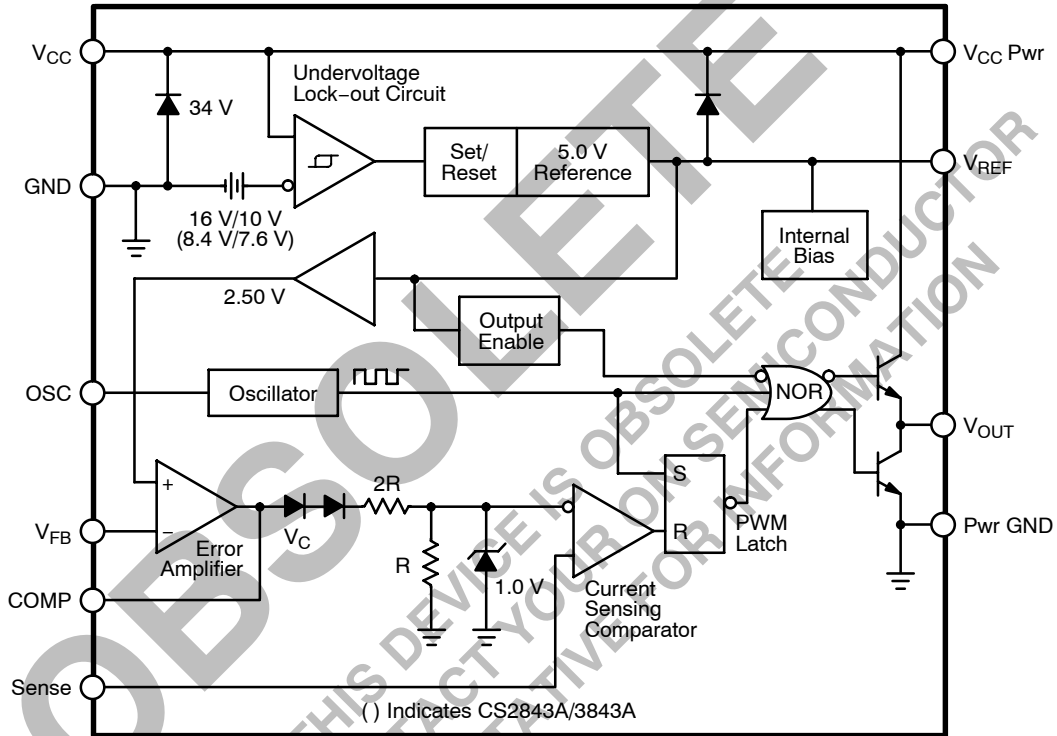
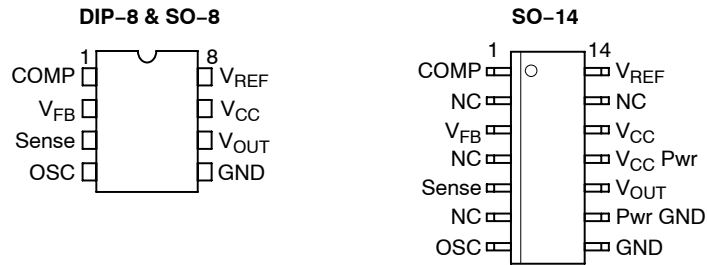

Figure 1. Block Diagram

CS2842A, CS3842A, CS2843A, CS3843A

MAXIMUM RATINGS*

Rating	Value	Unit
Supply Voltage ($I_{CC} < 30 \text{ mA}$)	Self Limiting	–
Supply Voltage (Low Impedance Source)	30	V
Output Current	± 1.0	A
Output Energy (Capacitive Load)	5.0	μJ
Analog Inputs (V_{FB} , Sense)	–0.3 to + 5.5	V
Error Amp Output Sink Current	10	mA
Package Thermal Resistance, PDIP–8 Junction–to–Case, $R_{\theta JC}$ Junction–to–Ambient, $R_{\theta JA}$	52 100	$^{\circ}\text{C/W}$ $^{\circ}\text{C/W}$
Package Thermal Resistance, SO–8 Junction–to–Case, $R_{\theta JC}$ Junction–to–Ambient, $R_{\theta JA}$	45 165	$^{\circ}\text{C/W}$ $^{\circ}\text{C/W}$
Package Thermal Resistance, SO–14 Junction–to–Case, $R_{\theta JC}$ Junction–to–Ambient, $R_{\theta JA}$	30 125	$^{\circ}\text{C/W}$ $^{\circ}\text{C/W}$
Lead Temperature Soldering:	Wave Solder (through hole styles only) (Note 1) Reflow (SMD styles only) (Note 2)	260 peak 230 peak $^{\circ}\text{C}$ $^{\circ}\text{C}$

1. 10 second maximum.

2. 60 second maximum above 183°C.

*The maximum package power dissipation must be observed.

ELECTRICAL CHARACTERISTICS ($-25^{\circ} \leq T_A \leq 85^{\circ}$ for CS2842A/CS2843A, $0^{\circ} \leq T_A \leq 70^{\circ}$ for CS3842A/CS3843A.

$V_{CC} = 15 \text{ V}^*$; $R_T = 680 \Omega$, $C_T = 0.022 \mu\text{F}$ for triangular mode, $R_T = 10 \text{ k}\Omega$, $C_T = 3.3 \text{ nF}$ for sawtooth mode (see Figure 7); unless otherwise stated.)

Characteristic	Test Conditions	CS2842A/CS2843A			CS3842A/CS3843A			Unit
		Min	Typ	Max	Min	Typ	Max	
Reference Section								
Output Voltage	$T_J = 25^{\circ}\text{C}$, $I_{OUT} = 1.0 \text{ mA}$	4.95	5.00	5.05	4.90	5.00	5.10	V
Line Regulation	$12 \leq V_{IN} \leq 25 \text{ V}$	–	6.0	20	–	6.0	20	mV
Load Regulation	$1.0 \leq I_{OUT} \leq 20 \text{ mA}$	–	6.0	25	–	6.0	25	mV
Temperature Stability	Note 3.	–	0.2	0.4	–	0.2	0.4	$\text{mV}/^{\circ}\text{C}$
Total Output Variation	Line, Load, Temperature (Note 3.)	4.90	–	5.10	4.82	–	5.18	V
Output Noise Voltage	$10 \text{ Hz} \leq f \leq 10 \text{ kHz}$, $T_J = 25^{\circ}\text{C}$ (Note 3.)	–	50	–	–	50	–	μV
Long Term Stability	$T_A = 125^{\circ}\text{C}$, 1.0 kHrs. (Note 3.)	–	5.0	25	–	5.0	25	mV
Output Short Circuit	$T_A = 25^{\circ}\text{C}$	–30	–100	–180	–30	–100	–180	mA

Oscillator Section

Initial Accuracy	Sawtooth Mode (see Figure 7), $T_J = 25^{\circ}\text{C}$	47	52	57	47	52	57	kHz
	Triangular Mode (see Figure 7), $T_J = 25^{\circ}\text{C}$	47	52	57	44	52	60	kHz
Voltage Stability	$12 \leq V_{CC} \leq 25 \text{ V}$	–	0.2	1.0	–	0.2	1.0	%
Temperature Stability	Sawtooth Mode $T_{MIN} \leq T_A \leq T_{MAX}$ (Note 3.)	–	5.0	–	–	5.0	–	%
	Triangular Mode $T_{MIN} \leq T_A \leq T_{MAX}$ (Note 3.)	–	8.0	–	–	8.0	–	%
Amplitude	OSC peak to peak	–	1.7	–	–	1.7	–	V
Discharge Current	$T_J = 25^{\circ}\text{C}$	7.5	8.3	9.3	7.5	8.3	9.3	mA
	$T_{MIN} \leq T_A \leq T_{MAX}$	7.2	–	9.5	7.2	–	9.5	mA

3. These parameters, although guaranteed, are not 100% tested in production.

*Adjust V_{CC} above the start threshold before setting at 15 V.

CS2842A, CS3842A, CS2843A, CS3843A

ELECTRICAL CHARACTERISTICS (continued) ($-25^{\circ} \leq T_A \leq 85^{\circ}$ for CS2842A/CS2843A, $0^{\circ} \leq T_A \leq 70^{\circ}$ for CS3842A/CS3843A.
 $V_{CC} = 15\text{ V}^*$; $R_T = 680\ \Omega$, $C_T = 0.022\ \mu\text{F}$ for triangular mode, $R_T = 10\ \text{k}\Omega$, $C_T = 3.3\ \text{nF}$ for sawtooth mode (see Figure 7);
 unless otherwise stated.)

Characteristic	Test Conditions	CS2842A/CS2843A			CS3842A/CS3843A			Unit
		Min	Typ	Max	Min	Typ	Max	

Error Amp Section

Input Voltage	$V_{COMP} = 2.5\text{ V}$	2.45	2.50	2.55	2.42	2.50	2.58	V
Input Bias Current	$V_{FB} = 0$	-	-0.3	-1.0	-	-0.3	-2.0	μA
A_{VOL}	$2.0 \leq V_{OUT} \leq 4.0\text{ V}$	65	90	-	65	90	-	dB
Unity Gain Bandwidth	Note 4.	0.7	1.0	-	0.7	1.0	-	MHz
PSRR	$12 \leq V_{CC} \leq 25\text{ V}$	60	70	-	60	70	-	dB
Output Sink Current	$V_{FB} = 2.7\text{ V}$, $V_{COMP} = 1.1\text{ V}$	2.0	6.0	-	2.0	6.0	-	mA
Output Source Current	$V_{FB} = 2.3\text{ V}$, $V_{COMP} = 5.0\text{ V}$	-0.5	-0.8	-	-0.5	-0.8	-	mA
V_{OUT} High	$V_{FB} = 2.3\text{ V}$, $15\ \text{k}\Omega$ to ground	5.0	6.0	-	5.0	6.0	-	V
V_{OUT} Low	$V_{FB} = 2.7\text{ V}$, $15\ \text{k}\Omega$ to V_{REF}	-	0.7	1.1	-	0.7	1.1	V

Current Sense Section

Gain	Notes 5 & 6.	2.85	3.00	3.15	2.85	3.00	3.15	V/V
Maximum Input Signal	$V_{COMP} = 5.0\text{ V}$ (Note 5.)	0.9	1.0	1.1	0.9	1.0	1.1	V
PSRR	$12 \leq V_{CC} \leq 25\text{ V}$ (Note 5.)	-	70	-	-	70	-	dB
Input Bias Current	$V_{SENSE} = 0$	-	-2.0	-10	-	-2.0	-10	μA
Delay to Output	$T_J = 25^{\circ}\text{C}$ (Note 4.)	-	150	300	-	150	300	ns

Output Section

Output Low Level	$I_{SINK} = 20\text{ mA}$	-	0.1	0.4	-	0.1	0.4	V
	$I_{SINK} = 200\text{ mA}$	-	1.5	2.2	-	1.5	2.2	V
Output High Level	$I_{SOURCE} = 20\text{ mA}$	13	13.5	-	13	13.5	-	V
	$I_{SOURCE} = 200\text{ mA}$	12	13.5	-	12	13.5	-	V
Rise Time	$T_J = 25^{\circ}\text{C}$, $C_L = 1.0\ \text{nF}$ (Note 4.)	-	50	150	-	50	150	ns
Fall Time	$T_J = 25^{\circ}\text{C}$, $C_L = 1.0\ \text{nF}$ (Note 4.)	-	50	150	-	50	150	ns
Output Leakage	UVLO Active, $V_{OUT} = 0$	-	-0.01	-10.00	-	-0.01	-10.00	μA

Total Standby Current

Startup Current	-	-	0.5	1.0	-	0.5	1.0	mA
Operating Supply Current	$V_{FB} = V_{SENSE} = 0\text{ V}$, $R_T = 10\ \text{k}\Omega$, $C_T = 3.3\ \text{nF}$	11	17	-	11	17	-	mA
V_{CC} Zener Voltage	$I_{CC} = 25\text{ mA}$	-	34	-	-	34	-	V

4. These parameters, although guaranteed, are not 100% tested in production.

5. Parameters measured at trip point of latch with $V_{FB} = 0$.

6. Gain defined as: $A = \Delta V_{COMP} / \Delta V_{SENSE}$; $0 \leq V_{SENSE} \leq 0.8\text{ V}$.

*Adjust V_{CC} above the start threshold before setting at 15 V.

CS2842A, CS3842A, CS2843A, CS3843A

ELECTRICAL CHARACTERISTICS (continued) ($-25^{\circ} \leq T_A \leq 85^{\circ}$ for CS2842A/CS2843A, $0^{\circ} \leq T_A \leq 70^{\circ}$ for CS3842A/CS3843A. $V_{CC} = 15\text{ V}^*$; $R_T = 680\ \Omega$, $C_T = 0.022\ \mu\text{F}$ for triangular mode, $R_T = 10\ \text{k}\Omega$, $C_T = 3.3\ \text{nF}$ for sawtooth mode (see Figure 7); unless otherwise stated.)

Characteristic	Test Conditions	CS2842A			CS3842A			CS2843A/CS3843A			Unit
		Min	Typ	Max	Min	Typ	Max	Min	Typ	Max	
Undervoltage Lockout Section											
Start Threshold	–	15	16	17	14.5	16	17.5	7.8	8.4	9.0	V
Min. Operating Voltage	After Turn On	9.0	10	11	8.5	10	11.5	7.0	7.6	8.2	V

*Adjust V_{CC} above the start threshold before setting at 15 V.

PACKAGE PIN DESCRIPTION

Package Pin Number			Symbol	Description
DIP-8	SO-8	SO-14		
1	1	1	COMP	Error amp output, used to compensate error amplifier.
2	2	3	V_{FB}	Error amp inverting input.
3	3	5	Sense	Noninverting input to Current Sense Comparator.
4	4	7	OSC	Oscillator timing network with capacitor to ground, resistor to V_{REF} .
5	5	8	GND	Ground.
–	–	9	Pwr GND	Output driver ground.
6	6	10	V_{OUT}	Output drive pin.
–	–	11	V_{CC} Pwr	Output driver positive supply.
7	7	12	V_{CC}	Positive power supply.
8	8	14	V_{REF}	Output of 5.0 V internal reference.
–	–	2, 4, 6, 13	NC	No connection.

TYPICAL PERFORMANCE CHARACTERISTICS

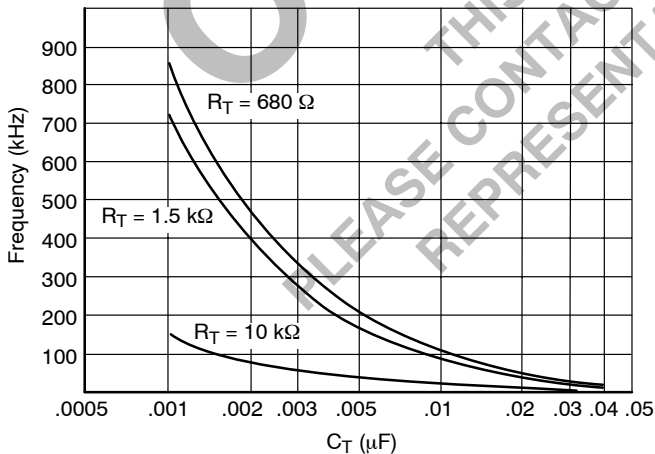

Figure 2. Oscillator Frequency vs. C_T

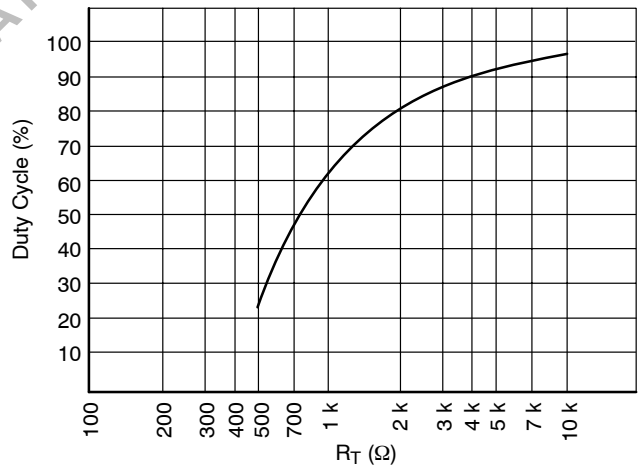

Figure 3. Oscillator Duty Cycle vs. R_T

CS2842A, CS3842A, CS2843A, CS3843A

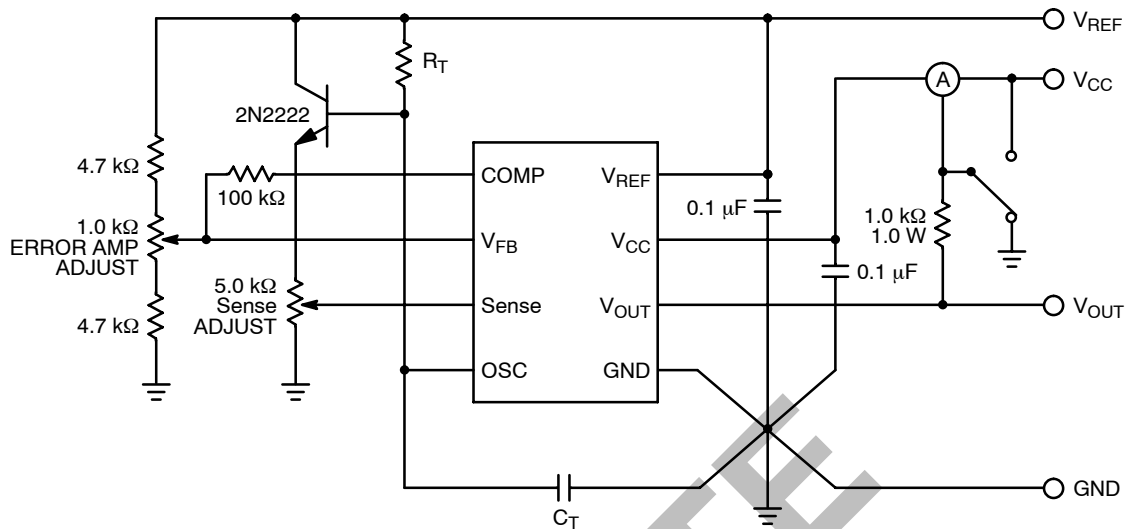

Figure 4. Test Circuit

CIRCUIT DESCRIPTION

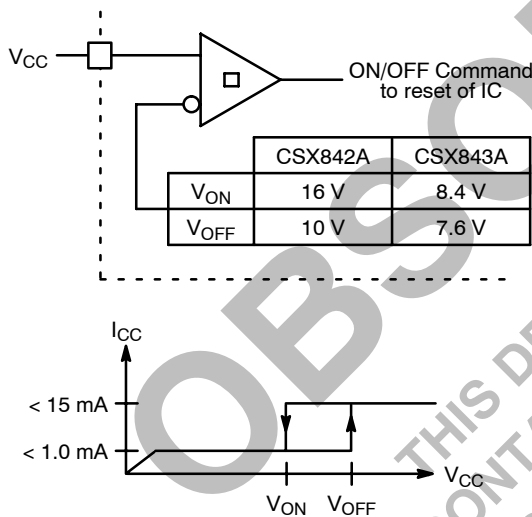

Figure 5. Typical Undervoltage Characteristics

Undervoltage Lockout

During Undervoltage Lockout (Figure 5), the output driver is biased to a high impedance state. The output should be shunted to ground with a resistor to prevent output leakage current from activating the power switch.

PWM Waveform

To generate the PWM waveform, the control voltage from the error amplifier is compared to a current sense signal which represents the peak output inductor current (Figure 6). An increase in V_{CC} causes the inductor current slope to increase, thus reducing the duty cycle. This is an inherent feed-forward characteristic of current mode control, since the control voltage does not have to change during changes of input supply voltage.

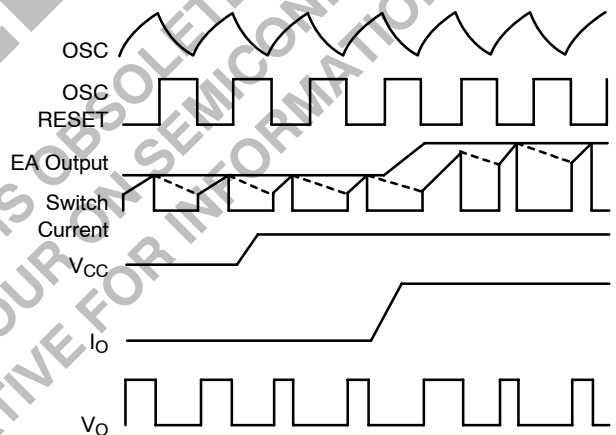

Figure 6. Timing Diagram for Key CS2841B Parameters

When the power supply sees a sudden large output current increase, the control voltage will increase allowing the duty cycle to momentarily increase. Since the duty cycle tends to exceed the maximum allowed to prevent transformer saturation in some power supplies, the internal oscillator waveform provides the maximum duty cycle clamp as programmed by the selection of oscillator components.

Setting the Oscillator

Oscillator timing capacitor, C_T, is charged by V_{REF} through R_T and discharged by an internal current source. During the discharge time, the internal clock signal blanks out the output to the Low state, thus providing a user selected maximum duty cycle clamp. Charge and discharge times are determined by the formula:

$$t_c = R_T C_T \ln \left(\frac{V_{REF} - V_{lower}}{V_{REF} - V_{upper}} \right)$$

$$t_d = R_T C_T \ln \left(\frac{V_{REF} - I_d R_T - V_{lower}}{V_{REF} - I_d R_T - V_{upper}} \right)$$

Substituting in typical values for the parameters in the above formulas:

$$V_{REF} = 5.0 \text{ V}$$

$$V_{upper} = 2.7 \text{ V}$$

$$V_{lower} = 1.0 \text{ V}$$

$$I_d = 8.3 \text{ mA}$$

$$t_c \approx 0.5534 R_T C_T$$

$$t_d = R_T C_T \ln \left(\frac{2.3 - 0.0083 R_T}{4.0 - 0.0083 R_T} \right)$$

The frequency and maximum duty cycle can be determined using the Typical Performance Characteristic graphs.

Grounding

High peak currents associated with capacitive loads necessitate careful grounding techniques. Timing and bypass capacitors should be connected close to GND pin in a single point ground.

The transistor and 5.0 kΩ potentiometer, shown in the test circuit, are used to sample the oscillator waveform and apply and adjustable ramp to Sense.

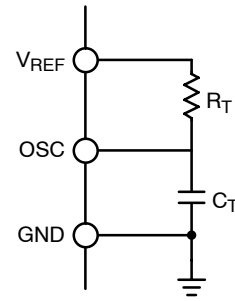

Timing Parameters

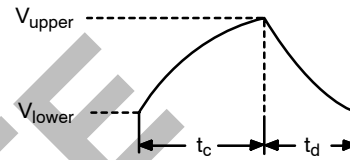

Sawtooth Mode

Large R_T ($\approx 10 \text{ k}\Omega$)

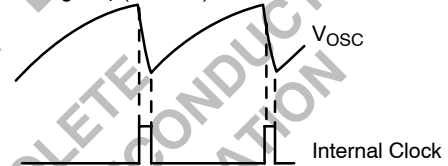

Triangular Mode

Small R_T ($\approx 700 \text{ k}\Omega$)

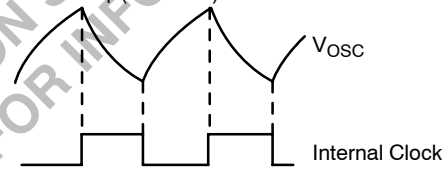

Figure 7. Oscillator Timing Network and Parameters

CS2842A, CS3842A, CS2843A, CS3843A

ORDERING INFORMATION

Device	Temperature Range	Package	Shipping
CS2842ALN8	-25°C to 85°C	DIP-8	50 Units/Rail
CS2843ALN8		DIP-8	50 Units/Rail
CS2842ALD14		SO-14	55 Units/Rail
CS2842ALDR14		SO-14	2500 Tape & Reel
CS3842AGN8	0°C to 70°C	DIP-8	50 Units/Rail
CS3842AGD8		SO-8	98 Units/Rail
CS3842AGDR8		SO-8	2500 Tape & Reel
CS3842AGD14		SO-14	55 Units/Rail
CS3842AGDR14		SO-14	2500 Tape & Reel
CS3843AGN8		DIP-8	50 Units/Rail
CS3843AGD8		SO-8	98 Units/Rail
CS3843AGDR8		SO-8	2500 Tape & Reel
CS3843AGD14		SO-14	55 Units/Rail
CS3843AGDR14		SO-14	2500 Tape & Reel

OBSOLETE
 THIS DEVICE IS OBSOLETE
 PLEASE CONTACT YOUR ON SEMICONDUCTOR
 REPRESENTATIVE FOR INFORMATION

CS2842A, CS3842A, CS2843A, CS3843A

PACKAGE DIMENSIONS

DIP-8
N SUFFIX
CASE 626-05
ISSUE L

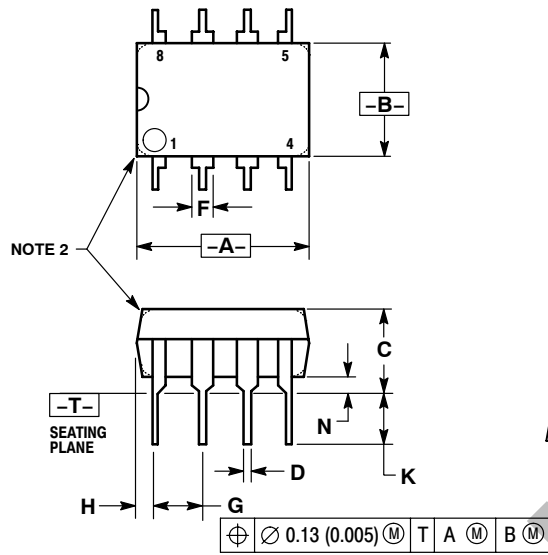

NOTES:

1. DIMENSION L TO CENTER OF LEAD WHEN FORMED PARALLEL.
2. PACKAGE CONTOUR OPTIONAL (ROUND OR SQUARE CORNERS).
3. DIMENSIONING AND TOLERANCING PER ANSI Y14.5M, 1982.

DIM	MILLIMETERS		INCHES	
	MIN	MAX	MIN	MAX
A	9.40	10.16	0.370	0.400
B	6.10	6.60	0.240	0.260
C	3.94	4.45	0.155	0.175
D	0.38	0.51	0.015	0.020
F	1.02	1.78	0.040	0.070
G	2.54 BSC		0.100 BSC	
H	0.76	1.27	0.030	0.050
J	0.20	0.30	0.008	0.012
K	2.92	3.43	0.115	0.135
L	7.62 BSC		0.300 BSC	
M	---	10°	---	10°
N	0.76	1.01	0.030	0.040

SO-8
D SUFFIX
CASE 751-07
ISSUE W

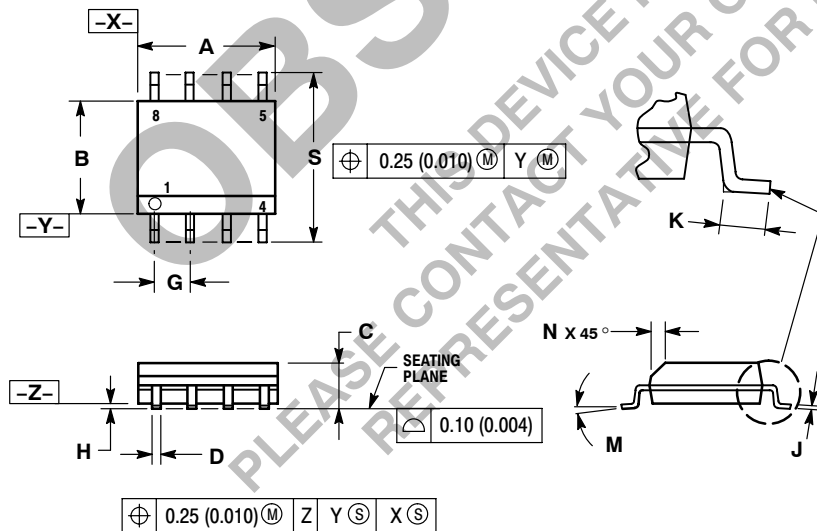

NOTES:

1. DIMENSIONING AND TOLERANCING PER ANSI Y14.5M, 1982.
2. CONTROLLING DIMENSION: MILLIMETER.
3. DIMENSION A AND B DO NOT INCLUDE MOLD PROTRUSION.
4. MAXIMUM MOLD PROTRUSION 0.15 (0.006) PER SIDE.
5. DIMENSION D DOES NOT INCLUDE DAMBAR PROTRUSION. ALLOWABLE DAMBAR PROTRUSION SHALL BE 0.127 (0.005) TOTAL IN EXCESS OF THE D DIMENSION AT MAXIMUM MATERIAL CONDITION.

DIM	MILLIMETERS		INCHES	
	MIN	MAX	MIN	MAX
A	4.80	5.00	0.189	0.197
B	3.80	4.00	0.150	0.157
C	1.35	1.75	0.053	0.069
D	0.33	0.51	0.013	0.020
G	1.27 BSC		0.050 BSC	
H	0.10	0.25	0.004	0.010
J	0.19	0.25	0.007	0.010
K	0.40	1.27	0.016	0.050
M	0°	8°	0°	8°
N	0.25	0.50	0.010	0.020
S	5.80	6.20	0.228	0.244

CS2842A, CS3842A, CS2843A, CS3843A

PACKAGE DIMENSIONS

SO-14
D SUFFIX
CASE 751A-03
ISSUE F

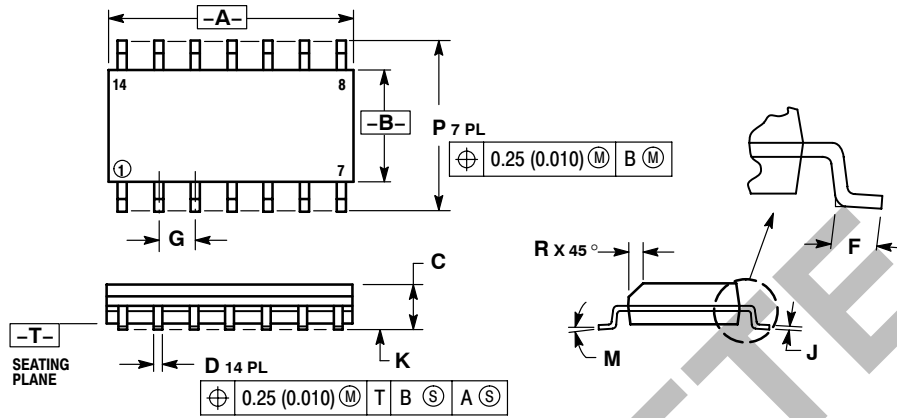

NOTES:

1. DIMENSIONING AND TOLERANCING PER ANSI Y14.5M, 1982.
2. CONTROLLING DIMENSION: MILLIMETER.
3. DIMENSIONS A AND B DO NOT INCLUDE MOLD PROTRUSION.
4. MAXIMUM MOLD PROTRUSION 0.15 (0.006) PER SIDE.
5. DIMENSION D DOES NOT INCLUDE DAMBAR PROTRUSION. ALLOWABLE DAMBAR PROTRUSION SHALL BE 0.127 (0.005) TOTAL IN EXCESS OF THE D DIMENSION AT MAXIMUM MATERIAL CONDITION.

DIM	MILLIMETERS		INCHES	
	MIN	MAX	MIN	MAX
A	8.55	8.75	0.337	0.344
B	3.80	4.00	0.150	0.157
C	1.35	1.75	0.054	0.068
D	0.35	0.49	0.014	0.019
F	0.40	1.25	0.016	0.049
G	1.27 BSC		0.050 BSC	
J	0.19	0.25	0.008	0.009
K	0.10	0.25	0.004	0.009
M	0°	7°	0°	7°
P	5.80	6.20	0.228	0.244
R	0.25	0.50	0.010	0.019

ON Semiconductor and are registered trademarks of Semiconductor Components Industries, LLC (SCILLC). SCILLC reserves the right to make changes without further notice to any products herein. SCILLC makes no warranty, representation or guarantee regarding the suitability of its products for any particular purpose, nor does SCILLC assume any liability arising out of the application or use of any product or circuit, and specifically disclaims any and all liability, including without limitation special, consequential or incidental damages. "Typical" parameters which may be provided in SCILLC data sheets and/or specifications can and do vary in different applications and actual performance may vary over time. All operating parameters, including "Typicals" must be validated for each customer application by customer's technical experts. SCILLC does not convey any license under its patent rights nor the rights of others. SCILLC products are not designed, intended, or authorized for use as components in systems intended for surgical implant into the body, or other applications intended to support or sustain life, or for any other application in which the failure of the SCILLC product could create a situation where personal injury or death may occur. Should Buyer purchase or use SCILLC products for any such unintended or unauthorized application, Buyer shall indemnify and hold SCILLC and its officers, employees, subsidiaries, affiliates, and distributors harmless against all claims, costs, damages, and expenses, and reasonable attorney fees arising out of, directly or indirectly, any claim of personal injury or death associated with such unintended or unauthorized use, even if such claim alleges that SCILLC was negligent regarding the design or manufacture of the part. SCILLC is an Equal Opportunity/Affirmative Action Employer. This literature is subject to all applicable copyright laws and is not for resale in any manner.

PUBLICATION ORDERING INFORMATION

LITERATURE FULFILLMENT:
Literature Distribution Center for ON Semiconductor
P.O. Box 5163, Denver, Colorado 80217 USA
Phone: 303-675-2175 or 800-344-3860 Toll Free USA/Canada
Fax: 303-675-2176 or 800-344-3867 Toll Free USA/Canada
Email: orderlit@onsemi.com

N. American Technical Support: 800-282-9855 Toll Free USA/Canada
Europe, Middle East and Africa Technical Support:
Phone: 421 33 790 2910
Japan Customer Focus Center
Phone: 81-3-5773-3850

ON Semiconductor Website: www.onsemi.com
Order Literature: <http://www.onsemi.com/orderlit>

For additional information, please contact your local Sales Representative

CS2842A/D