

Not Recommended for New Designs

This product was manufactured for Maxim by an outside wafer foundry using a process that is no longer available. It is not recommended for new designs. The data sheet remains available for existing users.

A Maxim replacement or an industry second-source may be available. Please see the QuickView data sheet for this part or contact technical support for assistance.

For further information, [contact Maxim's Applications Tech Support](#).

MAXIM

Low-Voltage Reference

ICL8069

General Description

The ICL8069 is a 1.2V temperature-compensated voltage reference. It uses the bandgap principle to achieve excellent stability and low noise at reverse currents down to 50µA. Maxim's ICL8069 also features excellent stability, freedom from oscillation.

Applications

- Analog-to-Digital Converters
- Digital-to-Analog Converters
- Threshold Detectors
- Voltage Regulators
- Portable Instruments

Features

- ◆ Temperature Coefficient Guaranteed to 10ppm/°C max
- ◆ Low Bias Current: 50µA min
- ◆ Low Dynamic Impedance
- ◆ Low Reverse Voltage
- ◆ Low Cost

Ordering Information

PART	TEMP RANGE	PIN-PACKAGE	MAX TEMPCO (ppm/°C)
ICL8069BCSA	0°C to +70°C	8 SO	25
ICL8069CCSA	0°C to +70°C	8 SO	50
ICL8069DCSA	0°C to +70°C	8 SO	100
ICL8069DESA	-40°C to +85°C	8 SO	100
ICL8069CCZQ	0°C to +70°C	TO-92	50
ICL8069DCZQ	0°C to +70°C	TO-92	100

Ordering Information continued at end of data sheet.

Typical Operating Circuit

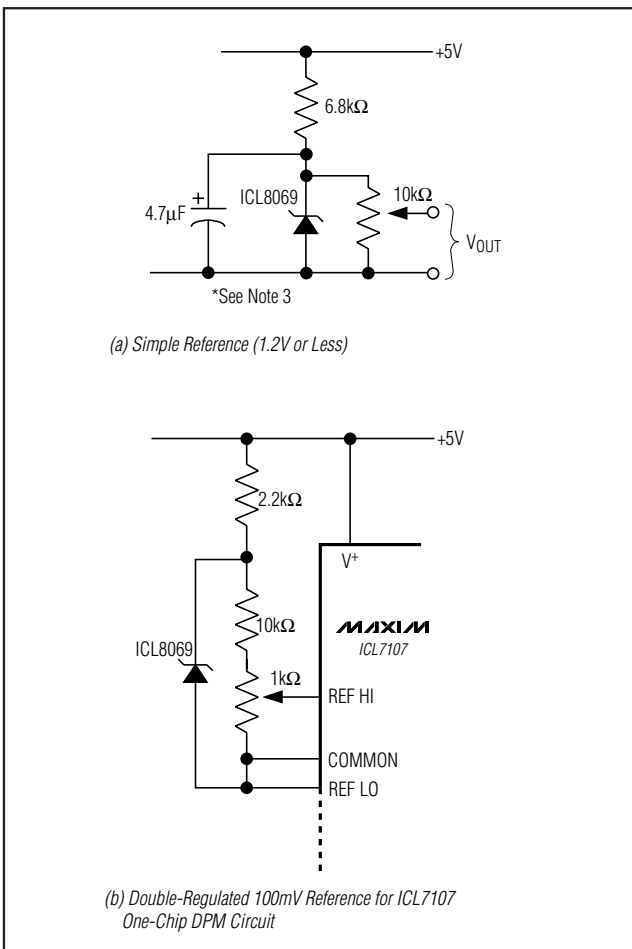

Pin Configurations

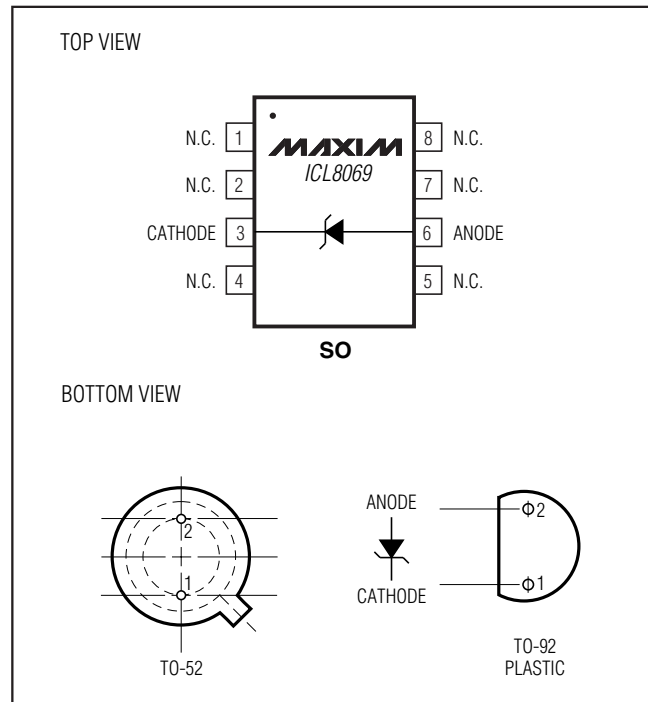

MAXIM

Maxim Integrated Products 1

For pricing, delivery, and ordering information, please contact Maxim/Dallas Direct! at 1-888-629-4642, or visit Maxim's website at www.maxim-ic.com.

Low-Voltage Reference

ICL8069

ABSOLUTE MAXIMUM RATINGS

Reverse Voltage(Note 1)
 Forward Current 10mA
 Reverse Current 10mA
 Power Dissipation Limited by Max Forward/Reverse Current
 Storage Temperature Range -65°C to +150°C

Operating Temperature Ranges

ICL8069C 0°C to +70°C
 ICL8069E -40°C to +85°C
 ICL8069M -55°C to +125°C
 Lead Temperature (soldering, 10s) +300°C

Note 1: In normal use, the reverse voltage cannot exceed the reference voltage. However, when plugging units into a powered-up test fixture, an instantaneous voltage equal to the compliance of the test circuit will be seen. This should not exceed 20V.

Stresses beyond those listed under "Absolute Maximum Ratings" may cause permanent damage to the device. These are stress ratings only, and functional operation of the device at these or any other conditions beyond those indicated in the operational sections of the specifications is not implied. Exposure to absolute maximum rating conditions for extended periods may affect device reliability.

ELECTRICAL CHARACTERISTICS

(T_A = +25°C, unless otherwise noted.) (Note 2)

PARAMETER	CONDITIONS		MIN	TYP	MAX	UNITS
Output Voltage	I _R = 500μA		1.20	1.23	1.25	V
Output Voltage Temperature Coefficient	I _R = 500μA, T _A = operating temperature range (Note 3)	ICL8069A			10	ppm/°C
		ICL8069B			25	
		ICL8069C			50	
		ICL8069D			100	
Output Voltage Change	50μA ≤ I _R ≤ 5mA			15	20	mV
Reverse Dynamic Impedance	I _R = 50μA, I _R = 500μA			1	2	Ω
				0.6	2	
Forward Voltage Drop	I _F = 500μA			0.7	1	V
RMS Noise Voltage	10Hz ≤ f ≤ 10kHz, I _R = 500μA			5		μV
Reverse Current Range			0.050		5	mA

Note 2: If circuit strays in excess of 200pF are anticipated, a 4.7μF shunt capacitor will ensure stability under all operating conditions.

Note 3: For military devices, measurements are made at +25°C, -55°C, and +125°C, while for commercial devices measurements are made at +25°C, 0°C, and +70°C. The units are then classified as a function of the worst-case TC. Sample tested to 0.1% AQL.

Low-Voltage Reference

Typical Operating Characteristics

($T_A = +25^\circ\text{C}$, unless otherwise noted.)

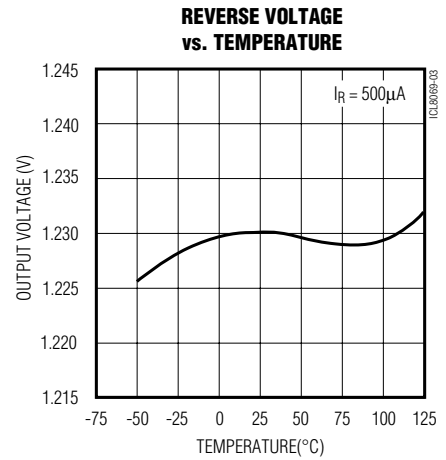
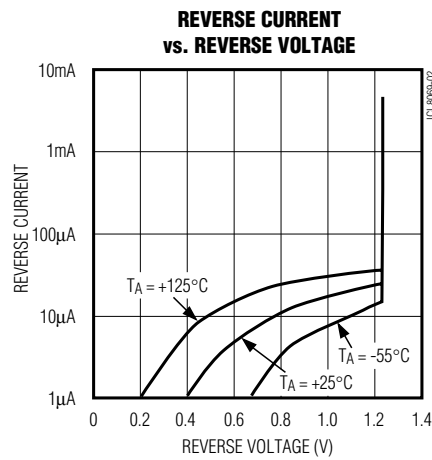
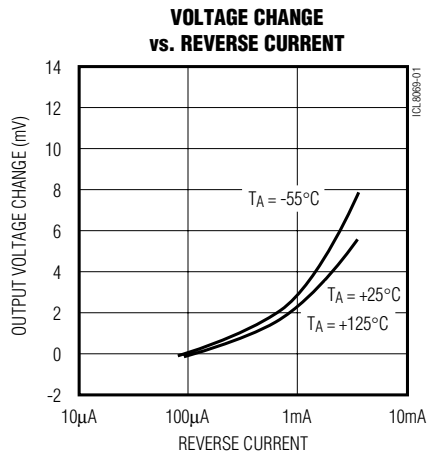

ICL8069

Ordering Information (continued)

PART	TEMP RANGE	PIN-PACKAGE	MAX TEMPCO (ppm/°C)
ICL8069ACSA*	0°C to +70°C	8 SO	10
ICL8069BCZQ*	0°C to +70°C	TO-92	25
ICL8069ACSQ*	0°C to +70°C	TO-52	10
ICL8069BCSQ*	0°C to +70°C	TO-52	25
ICL8069CCSQ*	0°C to +70°C	TO-52	50
ICL8069DCSQ*	0°C to +70°C	TO-52	100
ICL8069CMSQ*	-55°C to +125°C	TO-52	50
ICL8069DMSQ*	-55°C to +125°C	TO-52	100
ICL8069DC/D*	0°C to +70°C	Dice**	—

**Dice are specified at $T_A = +25^\circ\text{C}$.

*Contact factory for availability.

Low-Voltage Reference

Package Information

(The package drawing(s) in this data sheet may not reflect the most current specifications. For the latest package outline information, go to www.maxim-ic.com/packages.)

SYMBOL	INCHES		MILLIMETERS	
	MIN	MAX	MIN	MAX
A	.115	.150	2.92	3.81
f b	---	.021	---	.533
f b2	.016	.019	.406	.483
f D	.209	.230	5.31	5.84
f D1	.178	.195	4.52	4.95
e	.100 T.P.		2.54 T.P.	
e1	.050 T.P.		1.27 T.P.	
F	---	.030	---	.762
J	.036	.046	.914	1.17
k	.028	.048	.711	1.22
L	.500	---	12.70	---
L1	---	.050	---	1.27
L2	.250	---	6.35	---
Q	45° T.P.		45° T.P.	

NOTES: DIMENSIONS ARE COMPLIANT TO JEDEC, TO-52.

TOLERANCES UNLESS OTHERWISE SPECIFIED		MAXIM
FRACTIONS	DEC ANGLES	
* N/A	+ .001 ± N/A	PROPRIETARY INFORMATION
DRAWN BY:	DATE:	TITLE:
APPROVED BY:	DATE:	CASE OUTLINE TO-52, 2 LD
		DOCUMENT CONTRL NO. REV. A
		21-0020

TO82P0LEPFS

DIM	INCHES		MILLIMETERS	
	MIN	MAX	MIN	MAX
A	0.053	0.069	1.35	1.75
A1	0.004	0.010	0.10	0.25
B	0.014	0.019	0.35	0.49
C	0.007	0.010	0.19	0.25
e	0.050 BSC		1.27 BSC	
E	0.150	0.157	3.80	4.00
H	0.228	0.244	5.80	6.20
L	0.016	0.050	0.40	1.27

VARIATIONS:

DIM	INCHES		MILLIMETERS		N	MS012
	MIN	MAX	MIN	MAX		
D	0.189	0.197	4.80	5.00	8	AA
D	0.337	0.344	8.55	8.75	14	AB
D	0.386	0.394	9.80	10.00	16	AC

NOTES:
 1. D&E DO NOT INCLUDE MOLD FLASH.
 2. MOLD FLASH OR PROTRUSIONS NOT TO EXCEED 0.15mm (.006").
 3. LEADS TO BE COPLANAR WITHIN 0.10mm (.004").
 4. CONTROLLING DIMENSION: MILLIMETERS.
 5. MEETS JEDEC MS012.
 6. N = NUMBER OF PINS.

DALLAS MAXIM	
PROPRIETARY INFORMATION	
TITLE:	
PACKAGE OUTLINE, .150" SOIC	
APPROVAL	DOCUMENT CONTROL NO.
	21-0041
REV.	1/1
B	

SOICN LEPS

Maxim cannot assume responsibility for use of any circuitry other than circuitry entirely embodied in a Maxim product. No circuit patent licenses are implied. Maxim reserves the right to change the circuitry and specifications without notice at any time.

4 **Maxim Integrated Products, 120 San Gabriel Drive, Sunnyvale, CA 94086 408-737-7600**

© 2005 Maxim Integrated Products Printed USA **MAXIM** is a registered trademark of Maxim Integrated Products, Inc.