

## FEATURES

- Direct Replacement for Present References
- Ultra Low Drift—3ppm/°C Typ.
- Curvature Corrected
- Series or Shunt Operation
- Ultra High Line Rejection  $\approx 1/2$  ppm/V
- Low Output Impedance  $\approx 0.02\Omega$
- Tight Initial Output Voltage
- 100% Noise Tested

## APPLICATIONS

- A to D and D to A Converters
- Precision Regulators
- Constant Current Sources
- V to F Converters
- Bridge Excitation

## DESCRIPTION

The LT580/LT581 are bandgap voltage references utilizing thin film technology and a greatly improved curvature correction technique. Wafer level trimming of both reference and output voltage combines to produce units with high yields to very low TC and tight initial tolerance of output voltage.

The LT580/LT581 can both sink and source up to 10mA and can be used in either the series or shunt mode. This allows the reference to be used for both positive and negative output voltages without external components. Minimum input-output voltage is less than 1V in the series mode, providing improved tolerance of low line conditions.

For voltage references with improved specifications, please see the LT1019, LT1021, and LT1031 data sheets.

**3**

Negative 10V Reference for CMOS DAC

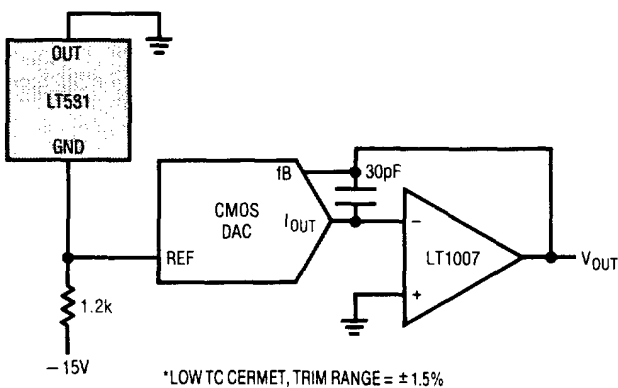

Output Voltage Drift

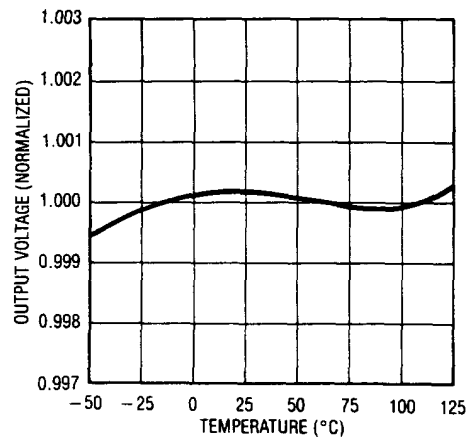

## ABSOLUTE MAXIMUM RATINGS

Input Voltage .....	40V
Storage Temperature Range .....	-65°C to 175°C
Lead Temperature (Soldering, 10 sec.) .....	300°C
Operating Temperature Range	
J, K, L, M Grades .....	0°C to 70°C
S, T, U Grades .....	-55°C to 125°C

## PACKAGE/ORDER INFORMATION

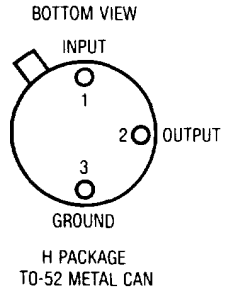
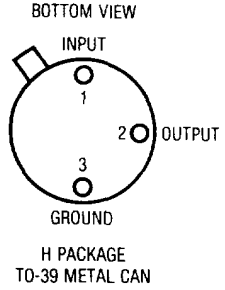
 <p>BOTTOM VIEW H PACKAGE TO-52 METAL CAN</p>	ORDER PART NUMBER
	LT580JH LT580KH LT580LH LT580MH LT580SH LT580TH LT580UH
 <p>BOTTOM VIEW H PACKAGE TO-39 METAL CAN</p>	LT581JH LT581KH LT581LH LT581SH LT581TH LT581UH

## LT580 ELECTRICAL CHARACTERISTICS $V_{IN} = +15V, T_A = 25^\circ C$ unless otherwise noted

SYMBOL	PARAMETER	CONDITIONS	LT580			UNITS
			MIN	TYP	MAX	
$V_R$	Output Voltage	LT580J	2.425	2.500	2.575	V
		LT580K, S	2.475	2.500	2.525	V
		LT580L, M, T, U	2.490	2.500	2.510	V
TC	Output Voltage Change Over Temperature in mV and (ppm/°C)	LT580J (0°C to 70°C)	●		15 (85)	mV (ppm/°C)
		LT580K (0°C to 70°C)	●		7 (40)	mV (ppm/°C)
		LT580L (0°C to 70°C)	●		4.3 (25)	mV (ppm/°C)
		LT580M (0°C to 70°C)	●		1.75 (10)	mV (ppm/°C)
		LT580S (-55°C to +125°C)	●		25 (55)	mV (ppm/°C)
		LT580T (-55°C to +125°C)	●		11 (25)	mV (ppm/°C)
		LT580U (-55°C to +125°C)	●		4.5 (10)	mV (ppm/°C)
$\frac{\Delta V_{OUT}}{\Delta V_{IN}}$	Line Regulation	$7V \leq V_{IN} \leq 30V$ LT580J, S		0.5	6	mV
		LT580K		0.5	4	mV
		LT580L, M, T, U		0.5	2	mV
		$4.5V \leq V_{IN} \leq 7V$ LT580J, S		0.1	3	mV
		LT580K		0.1	2	mV
		LT580L, M, T, U		0.1	1	mV
$\frac{\Delta V_{OUT}}{\Delta I_{OUT}}$	Load Regulation (Sourcing) Shunt Mode	$0 \leq I_{OUT} \leq 10mA$		1	10	mV
		$1.5mA \leq I_{SHUNT} \leq 10mA$		2	10	mV
$I_Q$	Quiescent Current			0.75	1.5	mA
$e_n$	Output Noise (Note 1)	0.1Hz to 10Hz		10		$\mu V_{p-p}$
	Output Voltage Stability with Time	Per Month		25		$\mu V$
		Long Term		250		$\mu V$

**LT581 ELECTRICAL CHARACTERISTICS**  $V_{IN} = +15V, T_A = 25^\circ C$  unless otherwise noted

SYMBOL	PARAMETER	CONDITIONS	LT581			UNITS
			MIN	TYP	MAX	
$V_R$	Output Voltage	LT581S, J	9.970	10.000	10.030	V
		LT581T, K	9.990	10.000	10.010	V
		LT581U, L	9.995	10.000	10.005	V
TC	Output Voltage Change, Maximum Deviation from 25°C in mV and (ppm/°C)	LT581J (0°C to 70°C)	●		13.5 (30)	mV (ppm/°C)
		LT581K (0°C to 70°C)	●		6.75 (15)	mV (ppm/°C)
		LT581L (0°C to 70°C)	●		2.25 (5)	mV (ppm/°C)
		LT581S (-55°C to +125°C)	●		30 (30)	mV (ppm/°C)
		LT581T (-55°C to +125°C)	●		15 (15)	mV (ppm/°C)
		LT581U (-55°C to +125°C)	●		10 (10)	mV (ppm/°C)
$\frac{\Delta V_{OUT}}{\Delta V_{IN}}$	Line Regulation	$15V \leq V_{IN} \leq 30V$		0.5	3	mV
		$13V \leq V_{IN} \leq 15V$		0.1	1	mV
$\frac{\Delta V_{OUT}}{\Delta I_{OUT}}$	Load Regulation (Sourcing) Shunt Mode	$0 \leq I_{OUT} \leq 5mA$		50	500	$\mu V/mA$
		$1mA \leq I_{SHUNT} \leq 5mA$		100	500	$\mu V/mA$
$I_Q$	Quiescent Current			0.75	1.0	mA
$e_n$	Output Noise (Note 1)	0.1Hz to 10Hz		30		$\mu Vp-p$
	Long Term Stability	Non-Cumulative		25		ppm/kHr
$I_{SC}$	Short Circuit Current			30		mA
$I_{OUT}$	Output Current	Sourcing	●	10	25	mA
		Sourcing	●	5		mA
		Sinking	●	5		mA

3

The ● denotes the specifications which apply over the full operating temperature range.

**Note 1:** Although 0.1Hz to 10Hz noise is not a standard production test, Linear Technology does 100% test 10Hz to 1kHz noise. Consult factory for details.

**TYPICAL APPLICATIONS**

High Current Precision Supply

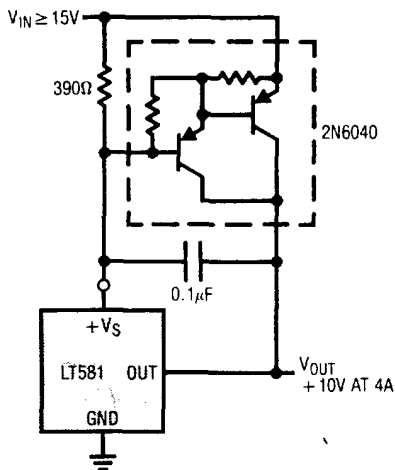

Suggested Output Trim

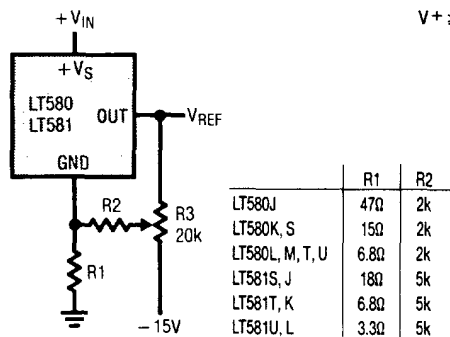

Output Current Boost with Current Limit

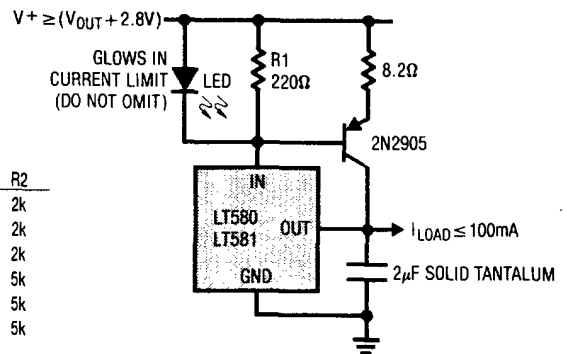

## TYPICAL APPLICATIONS

### Two-Terminal Negative Reference

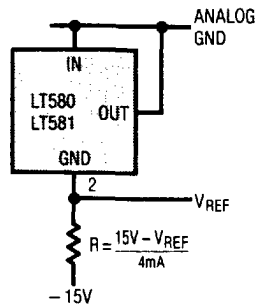

### 12V Supply Connection

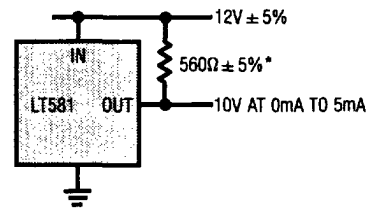

\*NOT REQUIRED ON LTC LT580 OR LT581

### Negative Series Reference

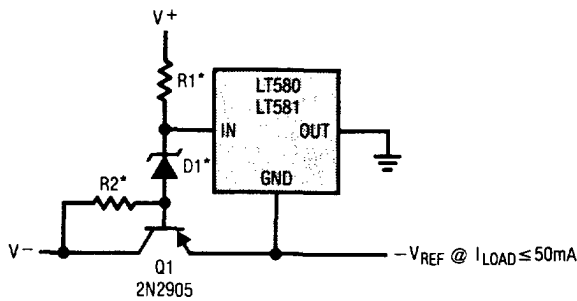

$$*R1 = \frac{V^+ - 5V}{2mA}, R2 = \frac{|V^-| - V_{REF}}{1mA}, D1 = V_{REF} + 5V$$

### Optional Trim Configuration

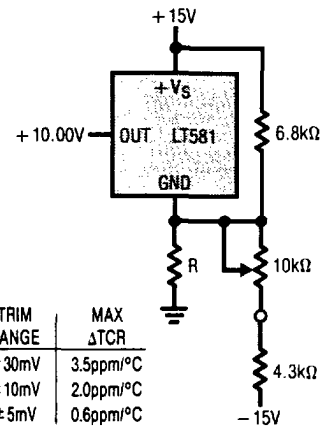

R	TRIM RANGE	MAX ΔTCR
220	±30mV	3.5ppm/°C
120	±10mV	2.0ppm/°C
3.90	±5mV	0.6ppm/°C

## PACKAGE DESCRIPTION

### LT580 TO-52

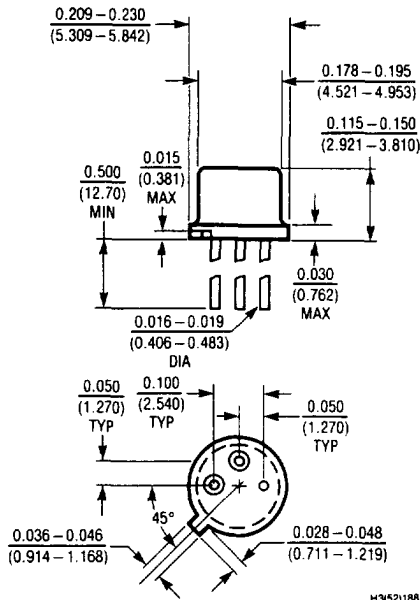

$T_{jmax}$	$\theta_{jA}$
150°C	360°C/W

### LT581 TO-39

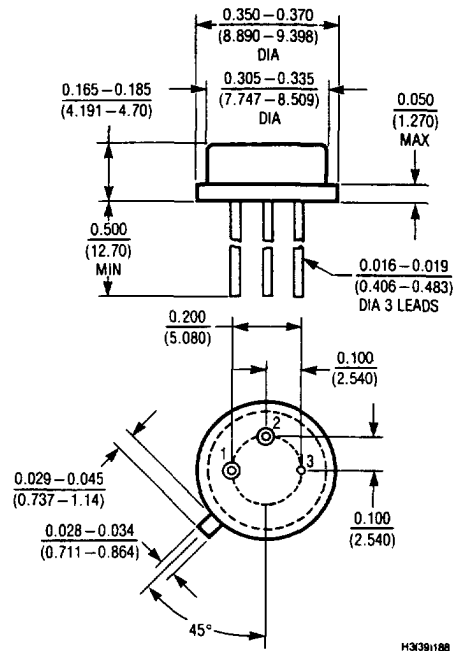

$T_{jmax}$	$\theta_{jA}$
150°C	150°C/W