

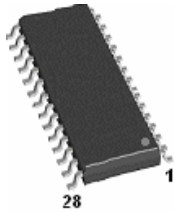

TS34118

Voice Switched Speakerphone Circuit

SOP-28



DIP-28

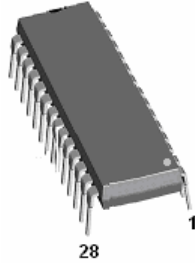

Supply Voltage Range -1.0 V to 7.0V

I_{VB} Current 500μA

Microphone Amplifier, & Hybrid Amplifier

Gain 40 dB

General Description

The TS34118 Voice Switched Speakerphone Circuit incorporates the necessary amplifiers, attenuators, level detectors, and control algorithm to form the heart of a high quality hands-free speakerphone system. Included are a microphone amplifier with adjustable gain and MUTE control, Transmit and Receive attenuators which operate in a complementary manner, level detectors at both input and output of both attenuators, and background noise monitors for both the transmit and receive channels. A Dial Tone Detector prevents the dial being attenuated by the Receive background noise monitor circuit. Also included are two line drive amplifiers which can be used to form a hybrid network in conjunction with an external coupling transformer. A high-pass filter can be used to filter out 60Hz noise in the receive channel, or for other filtering functions. A Chip Disable pin permits powering down the entire circuit to conserve power on long loops where loop current is at a minimum.

The TS34118 may be operated from a power supply, or it can be powered from the telephone line, requiring typically 5.0mA. The TS34118 can be interfaced directly to Tip and Ring (through a coupling transformer) for stand-alone operation, or it can be used in conjunction with a handset speech network and/or other features of a feature phone

Features

- ◇ Improved attenuator gain range: 52dB between transmit and receive.
- ◇ Low voltage operation for line-powered applications (3.0-6.5V).
- ◇ 4-point signal sensing for improved sensitivity.
- ◇ Back ground noise monitors for both transmit and receive paths.
- ◇ Standard 28-pin plastic DIP package and SOP package available.
- ◇ Microphone amplifier gain set by external resistors-mute function included.
- ◇ Chip disable for active/standby operation.
- ◇ On board filter pinned-out for user defined function.
- ◇ Dial tone detector to inhibit receive idle mode during dial tone presence.
- ◇ Compatible with TS34119 speaker amplifier.

Ordering Information

Part No.	Operating Temp.	Package
TS34118CD	-20 ~ +70 °C	DIP-28
TS34118CS		SOP-28

Absolute Maximum Rating

Description	Value	Unit
Supply voltage (pin 4)	-1.0, +7.0	V
Voltage at CD (pin 3), MUT (pin 12)	-1.0,V _{cc} +1.0	V
Voltage at VLC (pin 13)	-1.0,V _{cc} +0.5	V
Voltage at TXI (pin 9),RXI (pin 21),FI(pin 2)	-0.5,V _{cc} +0.5	V
Storage temperature range	-65 to +150	°C



Recommended Operating Conditions					
Description	Min.	Typ.	Max.	Units	
Supply voltage (pin 4) (see Text)	3.5	--	6.5	V	
CD input (pin 3), MUT input (pin 12)	0	--	V _{CC}	V	
I _{VB} current (pin 15)	-	--	500	μA	
VLC (pin 13)	0.3xV _B	--	V _B	V	
Attenuator input signal voltage (pin 9,21)	0	--	350	mVrms	
Microphone amplifier, Hybrid amplifier gain	0	--	40	dB	
Load current @RXO, TXO (pins 8,22)	0	--	±2.0	mA	
@MCO (pin 10)	0	--	±1.0		
@HTO-, HTO+ (pin 6,5)	0	--	±5.0		
Ambient operating temperature range	-20	--	+60	°C	
Electrical Characteristics (T _A =+25, V _{CC} =5.0V, CD≤0.8V, unless noted)					
Parameter	Symbol	Min	Typ	Max	Unit
Power Supply					
V _{CC} supply current (V _{CC} =6.5V, CD=0.8V)	I _{CC}	--	5.5	8.0	mA
(V _{CC} =6.5V, CD=2.0V)		--	600	800	
CD input resistance (V _{CC} =V _{CD} =6.5V)	R _{CD}	50	90	--	KΩ
CD input voltage - High	V _{CDH}	2.0	--	V _{CC}	V
- Low	V _{CDL}	0	--	0.8	V
V _B output voltage (V _{CC} =3.5V)	V _B	--	1.3	--	V
(V _{CC} =5.0V)		1.8	2.1	2.4	
V _B output resistance (I _{VB} =1.0mA)	R _{OV_B}	--	400	--	Ω
V _B power supply rejection ratio (C _{VB} =220μF, f=1.0KHz)	PSRR	--	54	--	dB
Attenuators (T_A=+25°C)					
Receive attenuator gain (f=1.0KHz, V _{LC} =V _B)	G _{RX}	+4.0	+6.0	+8.0	dB
Rx model, RXI=150mVrms (V _{CC} =5.0V)		+4.0	+6.0	+8.0	
Rx model, RXI=150mVrms (V _{CC} =3.5V)		ΔG _{RX1}	-0.5	0	
Gain change -V _{CC} =3.5V versus V _{CC} =5.0V	ΔG _{RX2}	--	-25	-15	dB
AGC gain change -V _{CC} =2.8V versus V _{CC} =5.0V*	G _{RX1}	-22	-20	-17	
Idle model, RXI=150mVrms	ΔG _{RX3}	49	52	54	dB
Range (Rx to Tx model)	V _{CR}	27	35	--	
Volume control range (Rx model, 0.3V _B <V _{LC} <V _B)	V _{CR}	27	35	--	dB
RXO DC voltage (Rx model)	V _{RXO}	--	V _B	--	V
ΔRXO DC voltage (Rx to Tx model)	ΔV _{RXO}	--	±10	±150	mV
RXO high voltage (I _{out} =-1.0mA RXI=V _B +1.5V)	V _{RXOH}	3.7	--	--	V
RXO low voltage (I _{out} =+1.0mA, RXI=V _B -1.0, Output measured with respect to V _B)*	V _{RXOL}	--	-1.5	-1.0	V
RXI input resistance (RXI<350mVrms)	R _{RXI}	7.0	10	14	KΩ
Transmit attenuator gain (f=1.0KHz)	G _{TX}	+4.0	+6.0	+8.0	dB
Tx model, TXI=150mVrms		+4.0	+6.0	+8.0	
Idle model, TXI=150mVrms		ΔG _{TX1}	-22	-20	
Range (Tx to Rx model)	ΔG _{TX2}	49	52	54	dB
TXO DC voltage (Tx model)	V _{TXO}	--	V _B	--	
ΔTXO DC voltage (Tx to Rx model)	ΔV _{TXO}	--	±30	±150	mV
TXO High voltage (I _{out} =-1.0mA TXI=V _B +1.5V)	V _{TXOH}	3.7	--	--	V
TXO Low voltage (I _{out} =+1.0mA TXI=V _B -1.0V, Output measured with respect to V _B)*	V _{TXOL}	--	-1.5	-1.0	V



Electrical Characteristics ($T_A=+25$, $V_{CC}=5.0V$, $CD\leq 0.8V$, unless noted)						
Parameter	Symbol	Min	Typ	Max	Unit	
Attenuators-continued ($T_A=+25^\circ C$)						
TXI input resistance ($TXI<350mVrms$)	R_{TXI}	7.0	10	14	K Ω	
Gain tracking ($G_{RX} + G_{TX}$, @ Tx, Idle, Rx)*	G_{TR}	--	± 0.1	--	dB	
Attenuator Control ($T_A=+25^\circ C$)						
C_T voltage (pin 14- V_B) Rx model ($V_{LC}=V_B$) Idle model Tx model	V_{CT}	--	+240 0 -240	--	mV	
C_T source current (switching to Rx mode)	I_{CTR}	-85	-60	-40	μA	
C_T sink current (switching to Tx mode)	I_{CTT}	+40	+60	+85	μA	
C_T slow idle current	I_{CTS}	--	0	--	μA	
C_T fast idle internal resistance	R_{FI}	1.5	2.0	3.6	K Ω	
Microphone Amplifier ($T_A=+25^\circ C$, $V_{MUT}\leq 0.8V$, $A_{VCL}=31dB$ unless otherwise noted)						
Output offset ($V_{MCO}-V_B$, feedback $R=180K\Omega$)	MCO_{vos}	-50	0	+50	mV	
Open loop gain ($f<100Hz$)	A_{VOLM}	70	80	--	dB	
Gain bandwidth	GBW_M	--	1.0	--	MHz	
Output High voltage ($I_{out}=-1.0mA$, $V_{CC}=5.0V$)	V_{MCOH}	3.7	--	--	V	
Output Low voltage ($I_{out}=+1.0mA$)	V_{MCOL}	--	--	200	mV	
Input bias current (@MCI)	I_{BM}	--	-40	--	nA	
Muting ($\Delta Gain$) ($f=1.0KHz$, $V_{MUT}=2.0V$) ($300Hz<f<10KHz$)	GMT	-55 --	-- -68	--	dB	
MUT input resistance ($V_{CC}=V_{MUT}=6.5V$)	R_{MUT}	50	90	--	K Ω	
MUT Input-High	V_{MUTH}	2.0	--	V_{CC}	V	
MUT Input-Low	V_{MUTL}	0	--	0.8	V	
Hybrid Amplifiers ($T_A=+25^\circ C$)						
HTO-offset ($V_{HTO-}-V_B$, Feedback $R=51K\Omega$)	H_{VOS}	-20	0	+20	mV	
HTO- to HTO+ offset (Feedback $R=51K\Omega$)	HB_{VOS}	-30	0	+30	mV	
Open loop gain (HTI to HTO-, $f<100Hz$)	A_{VOLH}	60	80	--	dB	
Gain bandwidth	GBW_H	--	1.0	--	MHz	
Closed loop gain (HTO- to HTO+)	A_{VCLH}	-0.35	0	+0.35	dB	
Input bias current (@HTI)	I_{BH}	--	-30	--	nA	
HTO- High voltage ($I_{out}=-5.0mA$)	V_{HT-H}	3.7	--	--	V	
HTO- Low voltage ($I_{out}=+5.0mA$)	V_{HT-L}	--	--	250	mV	
HTO+ High voltage ($I_{out}=-5.0mA$)	V_{HT+H}	3.7	--	--	V	
HTO+ Low voltage ($I_{out}=+5.0mA$)	V_{HT+L}	--	--	450	mV	
Distortion ($300Hz<f<10KHz$, see Figure 1)	THD_H	--	0.3	--	%	
Level Detectors and Background Noise Monitors ($T_A=+25^\circ C$)						
Transmit-Receive switch threshold (Ratio of current at RLI1 + RLI2 to $20\mu A$ at TLI1 + TLI2 to switch from Tx to Rx)	I_{TH}	0.8	1.0	1.2		
Source current at RLO1, RLO2, TLO1, TLO2	I_{LSO}	--	-2.0	--	mA	
Sink current at RLO1, RLO2, TLO1, TLO2	I_{LSK}	--	4.0	--	μA	
CPR, CPT output resistance ($I_{out}=1.5mA$)	R_{CP}	--	35	--	Ω	
CPR, CPT leakage current	I_{CPLK}	--	-0.2	--	μA	
Filter ($T_A=+25^\circ C$)						
Voltage offset at FO ($V_{FO}-V_B$, $220K\Omega$ from V_B to FI)	FO_{vos}	-200	-90	0	mV	
FO sink current	I_{FO}	150	260	400	μA	
FI bias current	I_{FI}	--	-50	--	nA	

Electrical Characteristics ($T_A=+25$, $V_{CC}=5.0V$, $CD \leq 0.8V$, unless noted)

Parameter	Symbol	Min	Typ	Max	Unit
System Distortion ($T_A=+25^\circ C$, $f=1.0KHz$)					
Rx mode (from FI to RXO, FO connected to RXI)	THD_R	--	0.5	3.0	%
Tx mode (from MCI to HTO-/HTO+, includes Tx attenuator)	THD_T	--	0.8	3.0	%

1. All currents into a device pin are positive, those out of a pin are negative. Algebraic convention rather than magnitude is used to define limits.

Simplified Block Diagram

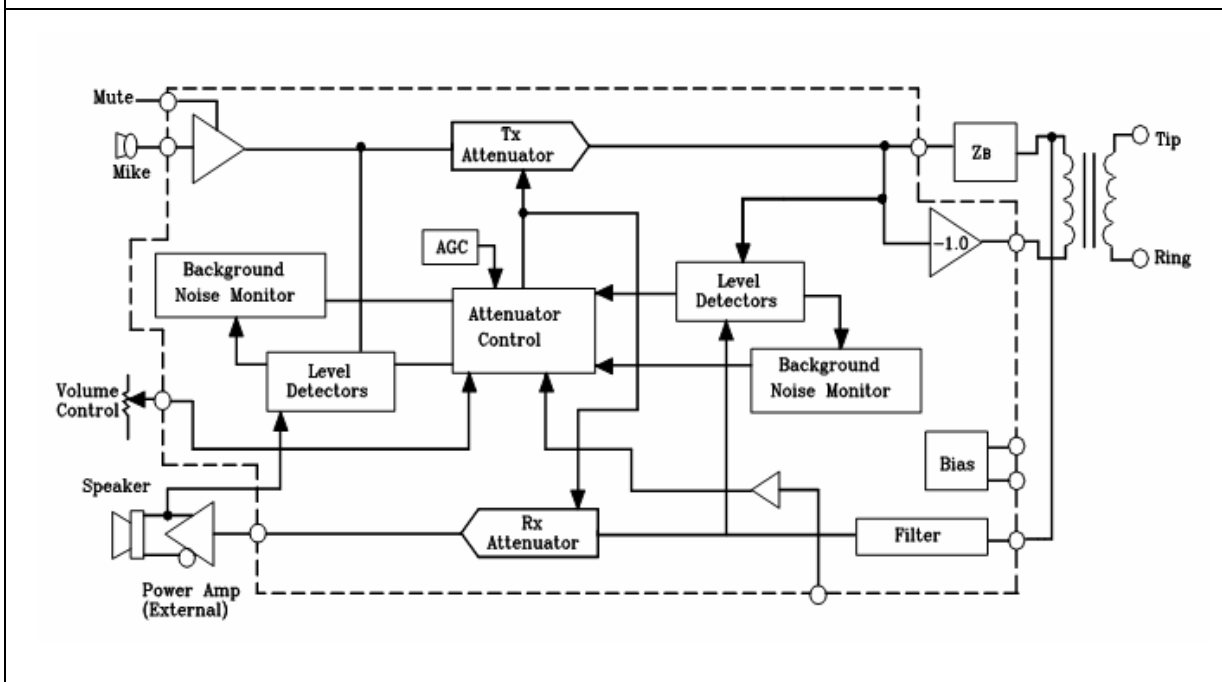

Temperature Characteristics

Parameter	Typical Value @25°C	Typical Change -20 to +60°C
Vcc supply current (CD=0.8V)	5.0mA	-0.3%/°C
Vcc supply current (CD=2.0V)	400µA	-0.4%/°C
V_B output voltage ($V_{CC}=5.0V$)	2.1V	+0.8%/°C
Attenuator gain (Max Gain)	+6.0dB	0.0008dB/°C
Attenuator gain (Max attenuation)	-46dB	0.004dB/°C
Attenuator input resistance (@ TXI, RXI)	10KΩ	+0.6%/°C
Dial tone detector threshold	15mV	+20µV/°C
CT source, sink current	±60µA	-0.15%/°C
Microphone, Hybrid amplifier offset	0 mV	±4.0µV/°C
Transmit-Receive switching threshold	1.0	±0.02%/°C
Sink current at RLO1, RLO2, TLO1, TLO2	4.0µA	-10nA/°C
Closed loop gain (HTO- to HTO+)	0 dB	0.001%/°C



Pin Function Description		
Pin	Name	Description
1	FO	Filter output. Output impedance is less than 50 ohms.
2	FI	Filter input. Input impedance is greater than 1.0Mohm.
3	CD	Chip Disable. A logic low(<0.8V) sets normal operation. A logic high (>2.0V) disables the IC to conserve power. Input impedance is nominally 90KΩ.
4	Vcc	A supply voltage of +2.8 to +6.5 volts is required, at ≈5.0mA. As Vcc falls from 3.5 to 2.8volts, an AGC circuit reduces the receive attenuator gain by ≈25dB (when in the receive mode).
5	HTO+	Output of the second hybrid amplifier. The gain is internally set at -1.0 to provide a differential output, in conjunction with HTO-, to the hybrid transformer.
6	HTO-	Output of the first hybrid amplifier. The gain of the amp is set by external resistors.
7	HTI	Input and summing node for the first hybrid amplifier. DC level is ≈V _B .
8	TXO	Output of the transmit attenuator. DC level is approximately V _B .
9	TXI	Input to the transmit attenuator. Max. Signal level is 350m V _{rms} . Input impedance is 10KΩ.
10	MCO	Output of the microphone amplifier. The gain of the amplifier is set by external resistors.
11	MCI	Input and summing node of the microphone amplifier. DC level is ≈ V _B .
12	MUT	Mute input. A logic low(<0.8V) sets normal operation. A logic high (>2.0V) mutes the microphone amplifier without affecting the rest of the circuit. Input impedance is nominally 90KΩ.
13	VLC	Volume control input. When VLC=V _B , the receive attenuator is at maximum gain when in the receive mode. When VLC=0.3V _B , the receive gain is down 35dB. Does not affect the transmit mode.
14	C _T	An RC at this pin sets the response time for the circuit to switch modes.
15	V _B	An output voltage ≈Vcc/2. This voltage is a system ac ground, and biases the volume control. A filter cap is required
16	CPT	An RC at this pin sets the time constant for the transmit background monitor.
17	TLI2	Input to the transmit level detector on the mike/speaker side.
18	TLO2	Output of the transmit level detector on the mike/speaker side, and input to the transmit background monitor.
19	RLO2	Output of the receive level detector on the mike/speaker side.
20	RLI2	Input to the receive level detector on the mike/speaker side.
21	RXI	Input to the receive attenuator and dial tone detector. Max input level is 350mV RMS. Input impedance is ≈10KΩ.
22	RXO	Output of the receive attenuator. DC level is approximately V _B .
23	TLI1	Input to the transmit level detector on the line side.
24	TLO1	Output of the transmit level detector on the line side.
25	RLO1	Output of the receive level detector on the line side, and input to the receive background monitor.
26	RLI1	Input to the receive level detector on the line side.
27	CPR	An RC at this pin sets the time constant for the receive background monitor.
28	GND	Ground pin for the entire IC.

Typical Application Circuit

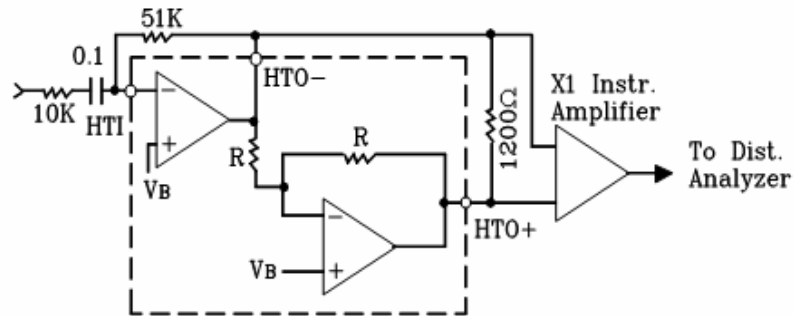

Figure 1. Hybrid Amplifier Distortion Test

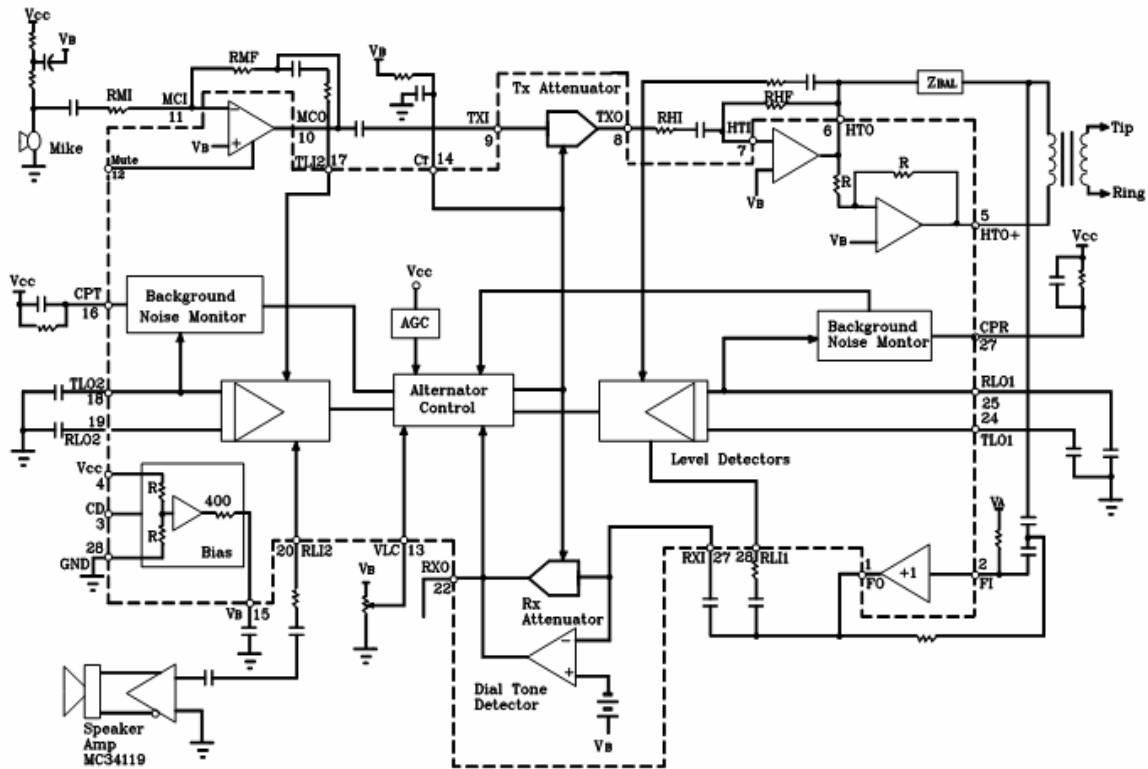

Figure 2. TS34118 Block Diagram

Introduction

The fundamental difference between the operation of a speakerphone and a handset is that of half-duplex versus full duplex. The handset is full duplex since con-versation can occur in both directions (transmit and receive) simultaneously. A speakerphone has higher gain levels in both paths and attempting to converse full duplex results in oscillatory problems due to the loop that exists within the system. The loop is formed by the receive and transmit paths, the hybrid, and the acoustic coupling (speaker to microphone). The only practical and economical solution used to date is to design the speakerphone to function in a half duplex mode – i.e. only one person speaks at a time, while the other listens. To achieve this required a circuit which can detect who is talking, switch on the appropriate path (transmit or receive) and switch off (attenuate) the other path. In this way, the loop gain is maintained less than unity. When the talkers exchange function, the circuit must quickly detect this, and switch the circuit appropriately. By providing speech level detectors the circuit operates in a “hands free” mode, eliminating the need for a “push to talk” switch.

The handset by the way, has the same loop as the speakerphone. But since the gains are considerably lower, and since the acoustic coupling from the earpiece to the mouthpiece is almost non-existent (the receiver is normally held against a person's ear.) oscillations don't occur.

The TS341118 provides the necessary level detectors, attenuators, and switching control for a properly operating speakerphone. The detection sensitivity and timing are externally controllable. Additionally, the TS34118 provides background noise monitor's which make the circuit insensitive to room and line noise, hybrid amplifier, and other associated functions, please refer to the Block Diagram (Figure 2) when reading the following sections.

Attenuators

The transmit and receive attenuators are complementary in function. i.e. when one is at maximum gain (+6.0dB), the other is at maximum attenuation (-4.5dB), and vice versa. The sum of their gains remains constant (within a nominal error band of ± 0.1 dB) at a typical value of ~ 40 dB (see Figure 10). Their purpose is to control the transmit and receive paths to provide the half-duplex operation required in a speakerphone.

The attenuators are non-inverting, and have a -3.0 dB (from max gain) frequency of 100KHz. The input impedance of each attenuator (TXI and RXI) is nominally $10\text{K}\Omega$ (see Figure 3), and the input signal should be limited to 350mVrms (990mVp-p) to prevent distortion. That maximum recommended input signal is independent of the volume control setting. The diode clamp on the inputs limits the input swing, and therefore the maximum negative output swing. This is the reason for V_{RXOL} and V_{TXOL} specification being defined as they are in the Electrical Characteristics. The output impedance is 10Ω until the output current limit typically 2.5mA is reached.

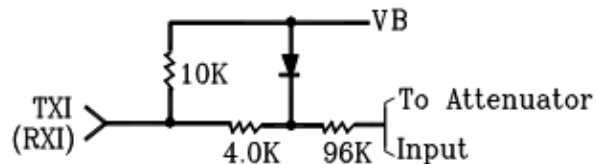

Figure 3. Attenuator Input Stage

Attenuators

The attenuators are controlled by the single output of the Control Block, which is measurable at the C_T pin (pin 14). When the C_T pin is at +240 millivolts with respect to V_B , the circuit is in the receive mode (receive attenuator is at +6.0dB). When the C_T voltage is at -240 millivolts with respect to V_B , the circuit is in the transmit mode (transmit attenuator is at +6.0dB). The circuit is in an idle mode when the C_T voltage is equal to V_B . Causing the attenuators gain to be halfway between their fully on and fully off positions (-20dB each). Monitoring the C_T voltage (with respect to V_B) is the most direct method of monitoring the circuit's mode.

The inputs to the Control Block are seven, 2 from the comparators operated by the level detectors, 2 from the background noise monitors, the volume control, the dial-tone detector, and the AGC circuit. These seven inputs are described below.

Level Detectors

There are four level detectors—two on the receive side and two on the transmit side. Refer to Figure 4. The terms in parentheses from one system, and the other terms from one system. Each level detector is a high gain amplifier with back-to-back diodes in the feedback path, resulting in non-linear gain, which permits operation over a wide dynamic range of speech levels. The sensitivity of each level detector is determined by the external resistor and capacitor at each input (TLI1, TLI2, RLI1 and RLI2). Each output charge an external capacitor through a diode and limiting resistor, thus providing a do representation of the input as signal level. The outputs have a quick rise time (determined by the capacitor and an internal 350Ω resistor), and a slow decay time set by an internal current source and the capacitor. The capacitors on the four outputs should have the same value ($\pm 10\%$) to prevent timing problems. Referring to Figure 2, on the receives side, one level detector (RLI1) is at the receive input receiving thus same signal as at Tip and Ring, and the other (PLI2) is at the output of the speaker amplifier. On the transmit side, one level detector (TLI2) is at the output of the microphone amplifier, while the other (TLI1) is at the hybrid output. Outputs RLO1 and TLO1 feed a comparator, the output of which goes to the Attenuator Control Block. Likewise, outputs RLO2 and TLO2 feed a second comparator which also goes to the Attenuator Control Block. The touch table for the effects of the level detectors on the Control Block is given in the section describing the Control Block.

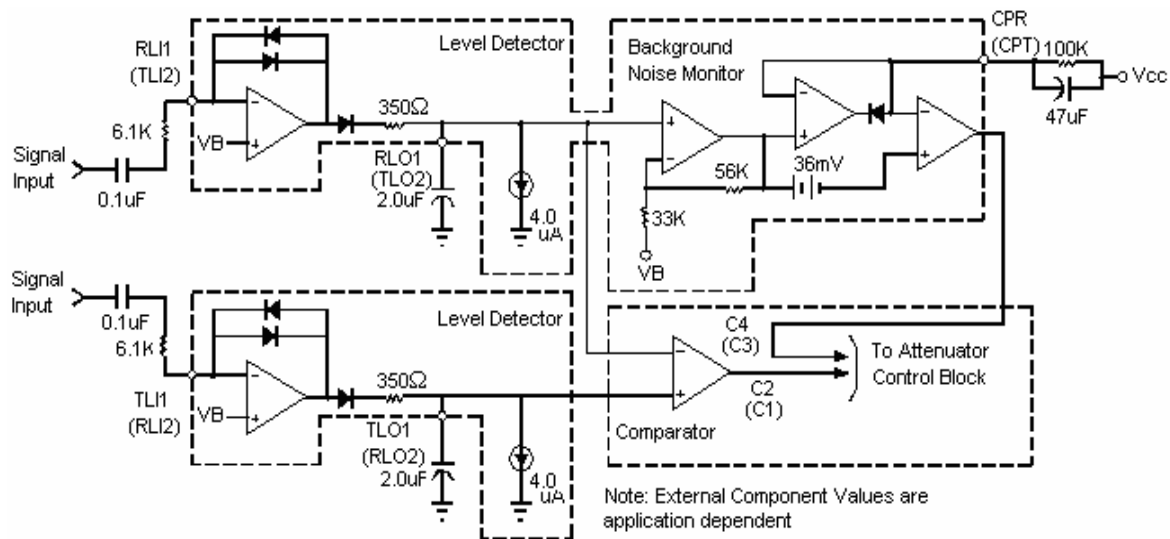

Figure 4. Level Detectors

Background Noise Monitors

The purpose of the background noise monitors is to distinguish speech (which consists of bursts) from background noise (a relatively constant signal level). There are two background noise monitors—one for the receive path and one for the transmit path. Referring to Figure 4, the receive background noise monitor is operated on by the RLI1-PLO1 level detector, while the transmit background noise monitor is operated on by the TLI2-TLO2 level detector. They monitor the background noise by storing a dc voltage representative of the respective noise levels in capacitors at CPR and CPT. The voltages at these pins have slow rise times (determined by the external RC), but fast decay times. If the signal at RLI1 (or TLI2) changes slowly, the voltage at CPR (or CPT) will remain more positive than the voltage at the non-inverting input of the monitor's output comparator. When speech is present, the voltage on the non-inverting input of the comparator will rise quicker than the voltage at the inverting input (due to the burst characteristic of speech), causing its output to change. This output is sensed by the Attenuator Control Block.

The 36mV offset at the comparator's input keeps the comparator from changing state unless the speech level exceeds the background noise by ≈ 4.0 dB. The time constant of the external RC (≈ 4.7 seconds) determines the response time to background noise variations.

Volume Control

The volume control input at VLC (pin 13) is sensed as a voltage with respect to V_B . The volume control affects the attenuators only in the receive mode. It has no effect in the idle or transmit modes.

When in the receive mode, the gain of the receive attenuator will be +6.0dB, and the gain of the transmit attenuator will be -46 dB only when VLC is equal to V_B . As VLC is reduced below V_B , the gain of the receive attenuator is reduced (see Figure 14), and the gain of the transmit attenuator is increased such that their sum remains constant. Changing the voltage at VLC changes the voltage at C_T (see the Attenuator Control Block section), which in turn controls the attenuators.

The volume control setting does not affect the maximum attenuator input signal at which noticeable distortion occurs. The bias current at VLC is typically 60nA out of the pin, and does not vary significantly with the VLC voltage or with V_{cc} .

Dial Tone Detectors

The dial tone detector is a comparator with one side connected to the receive input (RXI) and the other input connected to V_B with a 15mV offset (see Figure 5). If the circuit is in the receive mode, and the incoming signal is greater than 15mV (10mVrms), the comparator's output will change, disabling the receive idle mode. The receive attenuator will then be at a setting determined solely by the volume control.

The purpose of this circuit is to prevent the dial tone (which would be considered as continuous noise) from fading away as the circuit would have the tendency to switch to the idle mode. By disabling the receive idle mode, the dial tone remains at the normally expected full level.

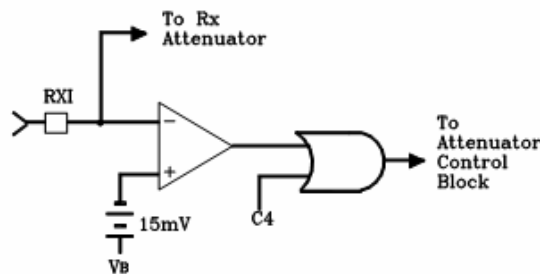

Figure 5. Dial Tone Detectors



Attenuator Control Block

The Attenuator Control Block has the seven inputs described above:

- The output of the comparator operated by RLO2 and TLO2 (microphone/speaker side) - designated C1.
- The output of the comparator operated by RLO1 and TLO1 (TIP/Ring side) – designated C2.
- The output of the transmit background noise monitor – designated C3.
- The output of the receive background noise monitor – designated C4.
- The volume control.
- The dial tone detector.
- The AGC circuit.

The single output of the Control Block controls the two attenuators. The effect of C1-C4 is as follows:

Input				Output
C1	C2	C3	C4	Mode
Tx	Tx	1	X	Transmit
Tx	Rx	Y	Y	Fast Idle
Rx	Tx	Y	y	Fast Idle
Rx	Rx	X	1	Receive
Tx	Tx	0	X	Slow Idle
Tx	Rx	0	0	Slow Idle
Rx	Tx	0	0	Slow Idle
Rx	Rx	X	0	Slow Idle

X=Don't Care; y=C3 and C4 are not both 0. A definition of the above terms:

- 1)"Transmit" means the transmit attenuator is fully on (+6.0dB), and the receive attenuator is at max. attenuation (-46dB).
- 2)"Receive" means both attenuators are controlled by the volume control. At max. Volume, the receive attenuator is fully on (+6.0dB), and the transmit attenuator is at max. attenuation (-46dB).
- 3)"Fast Idle" means both transmit and receive speech is present in approximately equal levels. The attenuators are quickly switched (30ms) to idle until one speech level dominates the other.
- 4)"Slow Idle" means speech has ceased in both transmit and receive paths. The attenuators are then slowly switched (1 second) to the idle mode.
- 5) Switch to the full transmit or receive modes from any other mode is at the fast rate (≈ 30 ms).

A summary of the truth table is as follows:

- 1)The circuit will switch to transmit if: a) both transmit level detectors sense higher signal levels relative to the respective receive level detectors (TLI1 versus RLI1, TLI2 versus RLI2), and b) the transmit background noise monitor indicates the presence of speech.
- 2)The circuit will switch to receive if: a) both receive level detectors sense higher signal levels relative to the respective transmit level detectors, and b) the receive background noise monitor indicates the presence of speech.
- 3) The circuit will switch to the fast idle mode if the level detectors disagree on the relative strengths of the signal levels, and at least one of the background noise monitors indicates speech. For example, referring to the Block Diagram (Figure 2), if there is sufficient signal at the microphone amp output (TLI2) to override the speaker signal (RLI2), and there is sufficient signal at the receive input (RLI1) to override the signal at the hybrid output (TLI1), and either or both background monitors indicate speech, then the circuit will be in the fast idle mode. Two conditions which can cause the fast idle mode to occur are a) when both talkers are attempting to gain control of the system by talking at the same time, and b)when one talker is in a very noisy environment, forcing the other talker to continually override that noise level. In general, the fast idle mode will occur infrequently.

Attenuator Control Block

4) The circuit will switch to the slow idle mode when a) both talkers are quiet (no speech present), or b) when one talker's speech level is continuously overridden by noise at the other speaker's location.

The time required to switch the circuit between transmit, receive, fast idle and slow idle is determined in part by the components at the CT pin (pin 14). (see the section on Switch Time for a more complete explanation of the switching time components). A schematic of the CT circuitry is shown in Figure 6, and operates as follows:

- RT is typically 120K Ω , and CT is typically 5.0 μ F.
- To switch to the receive mode, I1 is turned on (I2 is off), charging the external capacitor to +240mV above VB. (An internal clamp prevents further charging of the capacitor.)
- To switch to the transmit mode, I2 is turned on (I1 is off) bringing down the voltage on the capacitor to -240mV with respect to VB.
- To switch to idle quickly (fast idle), the current sources are turned off, and the internal 2.0K Ω resistor is switched in, discharging the capacitor to VB with a time constant = 2.0K \times CT.
- To switch to idle slowly (slowly idle), the current sources are turned off, the switch at the internal 2.0K Ω resistor is open, and the capacitor discharges to VB through the external resistor RT with a time constant = RT \times CT.

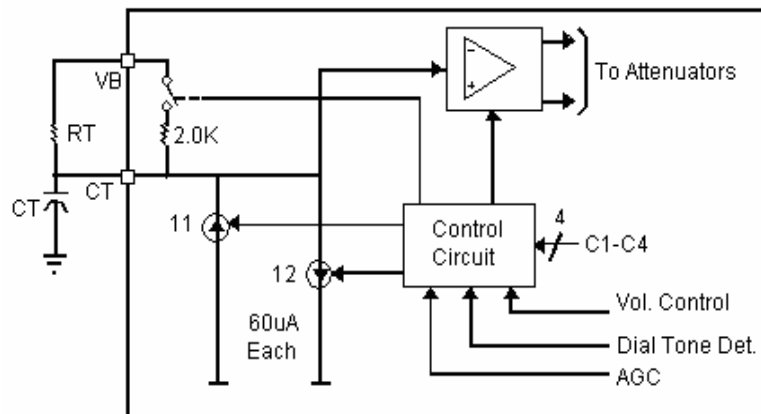

Figure 6. CT Attenuator Control Block Circuit

Microphone Amplifier

The microphone amplifier (pins 10,11) has the non-inverting input internally connected to VB, while the inverting input and the output are pinned out. Unlike most op-amps, the amplifier has an all-NPN output stage, which maximizes phase margin and gain-bandwidth. This feature ensures stability at gains less than unity, as well as with a wide range of reactive loads. The open loop gain is typically 80dB ($f < 100$ Hz), and the gain-bandwidth is typically 1.0MHz (see Figure 16). The maximum p-p output swing is typically 1.0 volt less than Vcc with an output impedance of $< 10 \Omega$ until current limited is reached (typically 1.5mA). Input bias current at MCI is typically 40nA out of the pin.

The muting function (Pin 12), when activated, will reduce the gain of the amplifier to ≈ -39 dB (with RMI=5.0K Ω) by shorting output to the inverting input (see Figure 7). The mute input has a threshold of ≈ 1.5 volts, and the voltage at this pin must be kept within the range of ground and Vcc (see Figure 17). If the mute function is not used, the pin should be grounded.

Microphone Amplifier

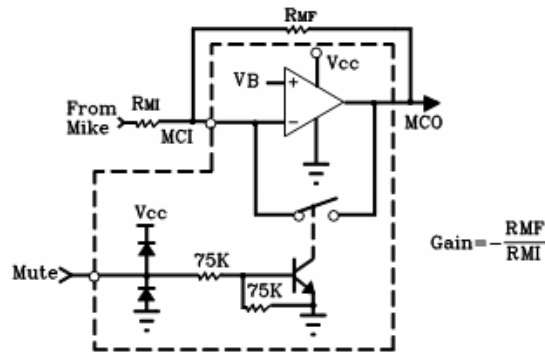

Figure 7. Microphone Amplifier and Mute

Hybrid Amplifiers

The two hybrid amplifiers (at HTO+, HTO-, and HTI), in conjunction with an external transformer, provide the two-to four wire converter for interfacing to the telephone line. The gain of the first amplifier (HTI to HTO-) is set by external resistors (gain= $-R_{HF}/P_{HI}$ in Figure 2), and its output drives the second amplifier, the gain of which is internally set at -1.0 . Unlike most op-amps, the amplifiers have all-NPN output stage, which maximizes phase margin and gain-bandwidth. This feature ensures stability at gains less than unity, as well as with a wide range of reactive loads. The open loop gain of the first amplifier is typically 80dB, and the gain bandwidth of each amplifier is $\approx 1.0\text{MHz}$ (see Figure 16). The maximum p-p output swing of each amplifier is typically 1.2 volts less than V_{cc} with an output impedance of $<10\Omega$ until current limiting is reached (typically 8.0mA). The output current capability is guaranteed to be a minimum of 5.0mA. The bias current at HTI is typically 30nA out of the pin.

The connections to the coupling transformer are shown in the Block Diagram (Figure 2). The block labeled Zbal is the balancing network necessary to match the line impedance.

Filter

The operation of the filter circuit is determined by the external components. The circuit within the TS34118, from pins FI to FO is a buffer with a high input impedance ($>1.0\text{M}\Omega$), and a low output impedance ($<50\Omega$). The configuration of the external components determines whether the circuit is a high-pass filter (as shown in Figure 2), a low-pass filter, or a band-pass filter.

As a high pass filter, with the components shown in Figure 8, the filter will keep out 60Hz (and 120Hz) hum which can be picked up by the external telephone lines.

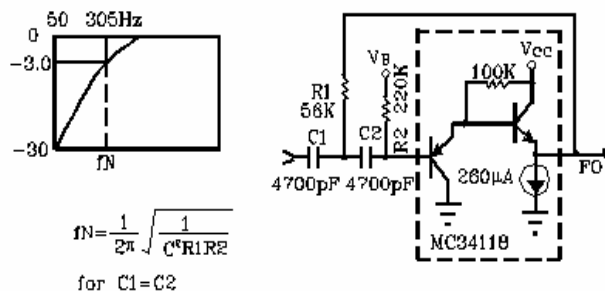

Figure 8. High Pass Filter

Filter

As a low pass filter (Figure 9), it can be used to roll off the high end frequencies in the receive circuit, which aids in protecting against acoustic feedback problems. With an appropriate choice of an input coupling capacitor to the low pass filter is formed

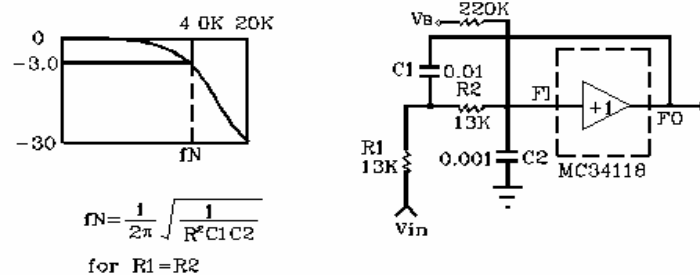

Figure 9. Low Pass Filter

Power Supply, V_B , and Chip Disable

The power supply voltage at V_{CC} (pin 4) is to be between 3.5 and 6.5 volts for normal operation, with reduced operation possible down to 2.8 volts. The power supply current is shown in Figure 18 for both the power-up and power-down mode.

The output voltage at V_B (pin 15) is $\approx (V_{CC} - 0.7)/2$, and provides the ac ground for the system. The output impedance at V_B is $\approx 400\Omega$ and in conjunction with the external capacitor at V_B , forms a low pass filter for power supply rejection with different capacitors. The choice of capacitor is application dependent based on whether the circuit is powered by the telephone line or a power supply.

Since V_B biases the microphone and hybrid amplifiers, the amount of supply rejection at their outputs is directly related to the rejection at V_B , as well as their respective gains. Depicts this graphically.

The Chip Disable (pin 3) permits powering down the IC to conserve power and/or for muting purposes. With $CD \leq 0.8$ volts, normal operation is in effect. With $CD \geq 2.0$ volts and $\leq V_{CC}$, the IC is powered down. In the powered down mode, the microphone and the hybrid amplifiers are disabled, and their outputs go to a high impedance state. Additionally, the bias is removed from the level detectors. The bias is not removed from the filter (pins 1,2). The attenuators (pin 8,9, 21, 22), or from pin 13,14, and 15 (the attenuators are disabled, however, and will not pass a signal). The input impedance at CD is typically $90K\Omega$, has a threshold of ≈ 1.5 volts, and the voltage at this pin must be kept within the range of ground and V_{CC} . If CD is not used, the pin should be grounded.

Switching Time

The switching time of the TS34118 circuit is dominated by the components at C_T (pin 14, refer to Figure 6), and secondarily by the capacitors at the level detector outputs (RLO1, RLO2, TLO1, TLO2).

The time to switch to receive or to transmit from idle is determined by the capacitor at C_T , together with the internal current sources (refer to Figure 6). The switching time is:

$$\Delta T = \Delta V \times C_T / I$$

For the typical case where $\Delta V = 240\text{mV}$, $I = 60\mu\text{A}$. And C_T is $50\mu\text{F}$, $\Delta T = 20\text{ms}$. If the circuit switches directly from receive to transmit (or vice-versa), the total switching time would be 40ms.

The switching time from either receive or transmit to idle depends on which type of idle mode is in effect. If the circuit is going to "fast idle", the time constant is determined by the C_T capacitor, and the internal $2.0K\Omega$ resistor (Figure 6). With $C_T = 5.0\mu\text{F}$, the time constant is $\approx 30\text{ms}$ (for 95% change). Fast idle is an infrequent occurrence, however, occurring when both speakers are talking and competing for control of the circuit. The switching time from idle back to either transmit or receive is described above.



Switching Time

If the circuit is switching to "slow idle", the time constant is determined by the C_T capacitor and R_T , the external resistor (see Figure 6). With $C_T = 5.0\mu\text{F}$, and $R_T = 120\text{K}\Omega$, the time constant is $\approx 600\text{ms}$, giving a switching time of ≈ 1.8 seconds (for 95% change). The switching period to slow idle begins when both speakers have stopped talking. The switching time back to the original mode will depend on how soon that speaker begins speaking again. The sooner the speaking time starts during the 1.8 seconds period, the quicker the switching time since a smaller voltage excursion is required. That switching time is determined by the internal current sources as described above.

The above switching times occur, however, after the level detectors have detected the appropriate signal levels, since their outputs operate the Attenuator Control Block. Referring to Figure 4, the rise time of the level detector's outputs to new speech is quick by comparison ($\approx 1.0\text{ms}$), determined by the internal 350Ω resistor and the external capacitor (typically $2.0\mu\text{F}$). The output's decay time is determined by the external capacitor, and an internal $4.0\mu\text{F}$ current source giving a decay rate of $\approx 60\text{ms}$ for 120mV excursion at RLO or TLO. However, the overall response time of the circuit is not a constant since it depends on the relative strength of the signals at the different level detectors, as well as the timing of the signals with respect to each other. The capacitors at the four outputs (RLO1, RLO2, TLO1, TLO2) must be equal value ($\pm 10\%$) to prevent problems in timing and level response.

The rise time of the level detector's outputs is not significant since it is so short. The decay time, however, provides a significant part of the "hold time" necessary to hold the circuit during the normal pauses in speech.

The components at the inputs of the level detectors (RLI1, RLI2, TLI1, TLI2) do not affect the switching time, but rather affect the relative signal levels required to switch the circuit, as well as the frequency response of the detectors.

Design Equations

Referring to Figure 10 (the coupling capacitors have been omitted for simplicity), the following definitions will be used (all measurements are at 1.0KHz)

- G_{MA} is the gain of the microphone amplifier measured from the microphone output to TXI (typically 35V/V , or 31dB);
- G_{TX} is the gain of the transmit attenuator, measured from TXI to TXO;
- G_{HA} is the gain of hybrid amplifiers, measured from TXO to the HTO-/HTO+ differential output (typically 10.2V/V , or 20.1dB);
- G_{HT} is the gain from HTO-/HTO+ to Tip/Ring for transmit signals, and includes the balance network (measured at 0.4V/V , or -8.0dB);
- G_{ST} is the side tone gain, measured from HTO-/HTO+ to the filter input (measured at 0.18V/V , or -15dB);
- G_{HR} is the gain from Tip/Ring to the filter input for receive signals (measured at 0.833V/V or -1.6dB);
- G_{FO} is the gain of the filter stage, measured from the input of the filter to RXI, typically 0dB at 1.0KHz ;
- G_{RX} is the gain of the receive attenuator measured from RXI to RXO;
- G_{SA} is the gain of the speaker amplifier, measured from RXO to the differential output of the TS34119 (typical 22V/V or 26.8dB);
- G_{AC} is the acoustic coupling, measured from the speaker differential voltage to the microphone output voltage.

I) Transmit Gain

The transmit gain, from the microphone output (V_M) to tip and Ring, is determined by the output characteristics of the microphone, and the desired transmit level. For example, a typical electret microphone will produce $\approx 0.35\text{mVrms}$ under normal speech conditions. To achieve 100mVrms at Tip / Ring, an overall gain of 285V/V is necessary. The gain of the transmit attenuator is fixed at 2.0 ($+6.0\text{dB}$), and the gain through the hybrid normally 0.4 (-8.0dB). Therefore a gain of 357V/V is required of the microphone and hybrid amplifiers. It is desirable to have the majority of that gain in the microphone amplifier for three reasons:

- 1) The low level signals from the microphone should be amplified as soon as possible to minimize signal/noise problems.

Design Equations

2) To provide a reasonable signal level to the TL12 level detector; and 3) to minimize any gain applied to broadband noise generated within the attenuator. However, to cover the normal voice band, the microphone amplifier's gain should not exceed 48dB. For the circuit of Figure 10, the gain of the microphone amplifier was set at 35V/V (31dB), and the differential gain of the hybrid amplifiers was set at 10.2V/V (20.1dB).

II) Receive Gain

The overall receive gain depends on the incoming signal level, and the desired output power at the speaker. Normal receive levels (independent of the peaks) at Tip/Ring can be 35mVrms (-27dBm). Although on long lines that level can be down to 8.0mVrms (-40dBm). The speaker power is:

$$PSPK = \frac{10dBm/10 \times 0.6}{R_s} \quad (\text{Equation 1})$$

Where R_s is the speaker impedance, and the dBm term is the incoming signal level increased by the gain of the receive path. Experience has shown that ≈ 30 dB gain is a satisfactory amount for the majority of applications. Using the above numbers and Equation 1, it would appear that the resulting power to the speaker is extremely low. However, Equation 1 does not consider the peaks in normal speech, which can be 10 to 15 times the rms value. Considering the peaks, the overall average power approaches 20-30mV on long lines, and much more on short lines.

Referring to Figure 10, the gain from Tip/Ring to the filter input was measured at 0.833V/V (-1.6dB), the filter's gain is unity, and the receive attenuator's gain is 2.0V/V (+6.0dB) at maximum volume. The speaker amplifier's gain is set at 22V/V (26.8dB), which puts the overall gain at ≈ 31.2 dB.

III) Loop Gain

The total loop gain must add up to less than zero dB to obtain a stable circuit. This can be expressed as:

$$G_{MA} + G_{TX} + G_{HA} + G_{ST} + G_{FO} + G_{RX} + G_{SA} + G_{AC} < 0 \quad (\text{Equation 2})$$

Using the typical numbers mentioned above, and knowing that $G_{TX} + G_{RX} = -40$ dB, the required acoustic coupling can be determined:

$$G_{AC} < [-31 + 20.1 + (-15) + 0 + (-40) + 26.8] = -22.9\text{dB} \quad (\text{Equation 3})$$

An acoustic loss of at least 23 dB is necessary to prevent instability and oscillations, commonly referred to as "singing." However, the following equations show that greater acoustic loss is necessary to obtain proper level detection and switching.

IV) Switching Threshold

To switch comparator C1, currents I1 and I3 need to be determined. Referring to Figure 11, with a receive signal V_L applied to Tip/Ring, a current I3 will flow through R3 into RL12 according to the following equation:

$$I_3 = \frac{V_L}{R_3} \left[G_{HR} \times G_{FO} \times G_{RX} \times \frac{G_{SA}}{2} \right] \quad (\text{Equation 4})$$

Where the terms in the brackets are the V/V gain terms. The speaker amplifier gain is divided by two since G_{SA} is the differential gain of the amplifier, and V_3 is obtained from one the side of the output. The current I1, coming from the microphone circuit, is defined by:

$$I_1 = \frac{V_M \times G_{MA}}{R_1} \quad (\text{Equation 5})$$

Where V_M is the microphone voltage. Since the switching threshold occurs when $I_1 = I_3$, combining the above two equations yields:

$$V_M = V_L \times \frac{R_1}{R_3} \left[\frac{G_{HR} \times G_{FO} \times G_{RX} \times G_{SA}}{G_{MA} \times 2} \right] \quad (\text{Equation 6})$$

Design Equations

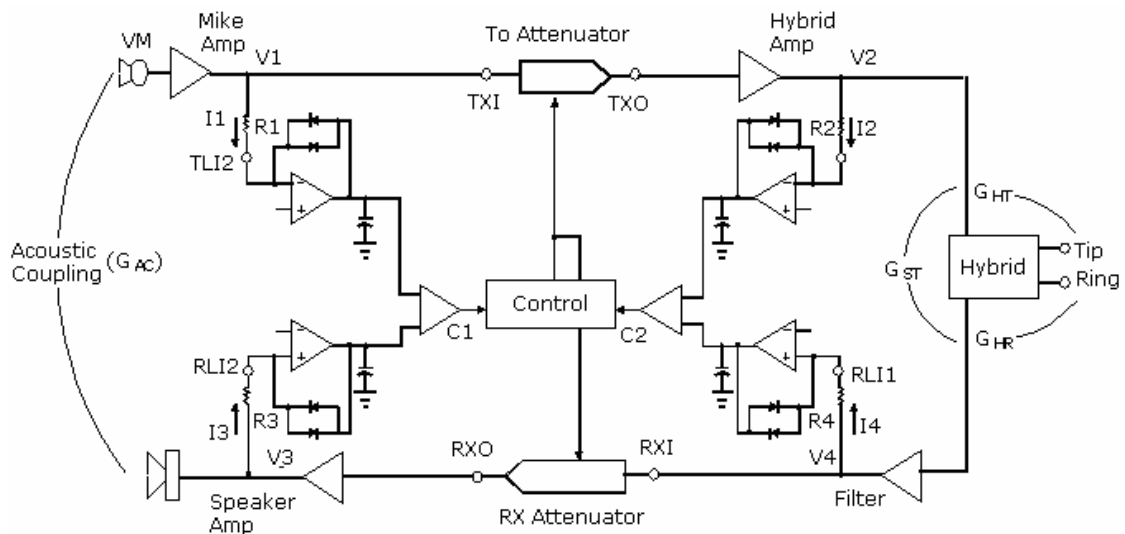

Figure 10. Basic Block Diagram For Design Purpos

This is the general equation defining the microphone voltage necessary to switch comparator C1 when a received signal V_L is present. The highest V_M occurs when the receive attenuator is at maximum gain (+6.0dB). Using the typical numbers for Equation 6 yields:

$$V_M = 0.52V_L \quad (\text{Equation 7})$$

To switch comparator C2, currents I2 and I4 need to be determined. With sound applied to the microphone, a voltage V_M is created by the microphone, resulting in a current I2 into TLI1:

$$I_2 = \frac{V_M}{R_2} \left[G_{MA} \times G_{TX} \times \frac{G_{HA}}{2} \right] \quad (\text{Equation 8})$$

Since G_{HA} is the differential gain of the hybrid amplifiers, it is divided by two to obtain the voltage V2 applied to R2. Comparator C2 switches when $I_4=I_2$. I4 is defined by:

$$I_4 = \frac{V_L}{R_4} [G_{HR} \times G_{FO}] \quad (\text{Equation 9})$$

Setting $I_4=I_2$, and combining the above equations results in:

$$V_L = V_M \times \frac{R_4}{R_2} \times \frac{[G_{MA} \times G_{TX} \times G_{HA}]}{[G_{HR} \times G_{FO} \times 2]} \quad (\text{Equation 10})$$

This equation defines the line voltage at Tip/Ring necessary to switch comparator C2 in the presence of a microphone voltage. The highest V_L occurs when the circuit is in the transmit mode ($G_{TX} = +6.0\text{dB}$). Using the typical numbers for Equation 10 yields:

$$V_L = 840V_M \quad (\text{or } V_M = 0.0019V_L) \quad (\text{Equation 11})$$

At idle, where the gain of the two attenuators is -20dB (0.1V/V), Equations 6 and 10 yield the same result:

$$V_M = 0.024V_L \quad (\text{Equation 12})$$

Equations 7, 11 and 12 define the thresholds for switching, and are represented in the following graph:

Design Equations

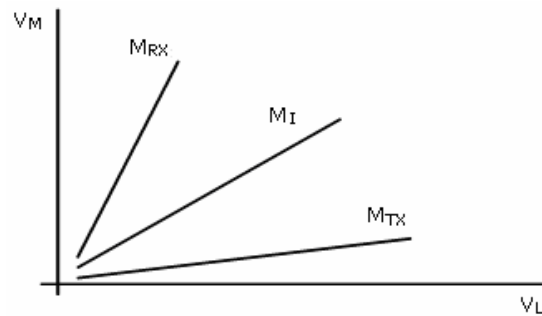

Figure 11. Switching Threshold

The “M” terms are the slopes of the lines (0.52, 0.024, and 0.0019) which are the coefficients of the three equations. The M_{RX} line represents the receive to transmit threshold in that it defines the microphone signal level necessary to switch to transmit in the presence of a given receive signal level. The M_{TX} line represents the transmit to receive threshold, The M_I line represents the idle condition, and defines the threshold level on one side (transmit or receive) necessary to overcome noise on the other.

Some comments on the above graph:

-Acoustic coupling and side tone coupling were not included in Equations 7 and 12. Those couplings will affect the actual performance of the final speakerphone due to their interaction with speech at the microphone, and the receive signal coming in at Tip/Ring. The effects of those couplings are difficult to predict due to their associated phase shifts and frequency response. In some cases the coupling signal will add, and other times subtract from the incoming signal. The physical design of the speakerphone enclosure, as well as the specific phone line to which it is connected, will affect the acoustic and side tone couplings, respectively.

-The M_{RX} line helps define the maximum acoustic coupling allowed in a system, which can be found from the following equation:

$$G_{AC-MAX} = \frac{R1}{2 \times R3 \times G_{MA}} \quad (\text{Equation 13})$$

Equation 13 is independent of the volume control setting. Conversely, the acoustic coupling of a designed system helps determine the minimum slope of that line. Using the component values in Equation 13 yields a G_{AC-MAX} of -37dB . Experience has shown, however, that an acoustic coupling loss of $>40\text{dB}$ is desirable.

-The M_{TX} line helps define the maximum side tone coupling (G_{ST}) allowed in the system, which can be found from the following equation:

$$G_{ST} = \frac{R4}{2 \times R2 \times G_{FO}} \quad (\text{Equation 14})$$

Using the component values in Equation 14 yields a maximum side tone of 0dB . Experience has shown, however, that a minimum of 6.0dB loss is preferable.

The above equations can be used to determine the resistor values for the level detector inputs. Equation 6 can be used to determine the $R1/R3$ ratio, and Equation 10 can be used to determine the $R4/R2$ ratio. In Figure 10, $R1-R4$ each represent the combined impedance of the resistor and coupling capacitor at each level detector input. The magnitude of each RC's impedance should be kept within the range of $2.0\text{K}-15\text{K}\Omega$ in the voice band (due to the typical signal levels present) to obtain the best performance from the level detectors. The specific R and C at each location will determine the frequency response of that level detector.



Application Information

Dial Tone Detector

The threshold for the dial tone detector is internally set at 15mV (10mVrms) below V_B (see Figure 5). That threshold can be reduced by connecting a resistor from RXI to ground. The resistor value is calculated from:

$$R = 10K \left[\frac{V_B}{\Delta V} - 1 \right]$$

Where V_B is the voltage at Pin 15, and ΔV is the amount of threshold reduction. By connecting a resistor from Vcc to RXI, the threshold can be increased. The resistor value is calculated from:

$$R = 10K \left[\frac{V_{CC} - V_B}{\Delta V} - 1 \right]$$

Where ΔV is the amount of threshold increase.

Background Noise Monitors

For testing or circuit analysis purposes, the transmit or receive attenuators can be set to the "on" position, by disabling the background noise monitors, and applying a signal so as to activate the level detectors. Grounding the CPR pin will disable the receive background noise monitor, thereby indicating the "presence of speech" to the attenuator control block. Grounding CPT does the same for the transmit path.

Additionally, the receive background noise monitor is automatically disabled by the dial tone detector whenever the receive signal exceeds the detector's threshold.

Transmit / Receive Detection Priority

Although the TS34118 was designed to have an idle mode such that the attenuators are halfway between their full on and full off positions, the idle mode can be biased towards the transmit or the receive side. With this done, gaining control of the circuit from idle will be easier for that side towards which it is biased since that path will have less attenuation at idle.

By connecting a resistor from C_T (pin 14) to ground, the circuit will be biased towards the transmit side. The resistor value is calculated from:

$$R = R_T \left[\frac{V_B}{\Delta V} - 1 \right]$$

Where R is the added resistor, R_T is the resistor normally between pins 14 and 15 (typically 120 Ω), and ΔV is the difference between V_B and the voltage at C7 at idle C refer to (Figure 10)

By connecting a resistor from C_T (pin 14) to Vcc, the circuit will be biased towards the transmit side. The resistor value is calculated from:

$$R = R_T \left[\frac{V_{CC} - V_B}{\Delta V} - 1 \right]$$

R, R_T , and ΔV are the same as above. Switching time will be somewhat affected in each case due to the different voltage excursions required to get to transmit and receive from idle. For practical considerations, the ΔV shift should not exceed 100mV.

Application Information

Volume Control

If a potentiometer with a standard linear taper is used for the volume control, In situations where this may be objectionable, a potentiometer with an audio taper (commonly used in radio volume controls) will provide a more linear relationship as indicated in Figure 12. The slight non-linearity at each end of the graph is due to the physical construction of the potentiometer, and will vary among different manufactures.

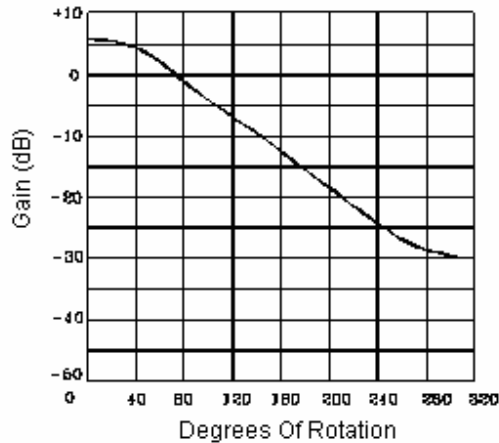

Figure 12. Receive Attenuator Gain versus Potentiometer Position Using Audio Taper

RFI Interference

Potential radio frequency interference problems should be addressed early in the electrical and mechanical design of the speakerphone. RFI may enter the circuit through Tip and Ring, through the microphone wiring to the microphone amplifier, or through any of the PC board traces. The most sensitive pins on the TS34118 are the inputs to the level detectors (RLI1, RLI2, TLI1, TLI2) since, when there is no speech present, the inputs are high impedance and these op amps are in a near open loop condition. The board traces to these pins should be kept short, and the resistor and capacitor for each of these pins should be physically close to the pins. Any other high impedance input pin (MCI, HTI, FI, VLC) should be considered sensitive to RFI signals.

The Final Analysis

Proper operation of a speakerphone is a combination of proper mechanical (acoustic) design as well as proper electronic design. The acoustics of the enclosure must be considered early in the design of a speakerphone. In general, electronics cannot compensate for poor acoustics, low speaker quality, or any combination of the two. Proper acoustic separation of the speaker and microphone, as described in the Design Equations, is essential. The physical location of the microphone, along with the characteristics of the selected microphone, will play a large role in the quality of the transmitted sound. The microphone and speaker vendors can usually provide additional information on the use of their products. In the final analysis, the circuits shown in this datasheet will have to be "fine tuned" to match the acoustics of the enclosure, the specific hybrid, and the specific microphone and speaker selected. The component values shown in this datasheet should be considered as starting points only. The gains of the transmit and receive paths are easily adjusted at the microphone and speaker amplifiers, respectively, The switching response can then be fine tuned by varying (in small steps) the components at the level detector inputs until satisfactory operation is obtained for both long and short lines

SOP-28 Mechanical Drawing

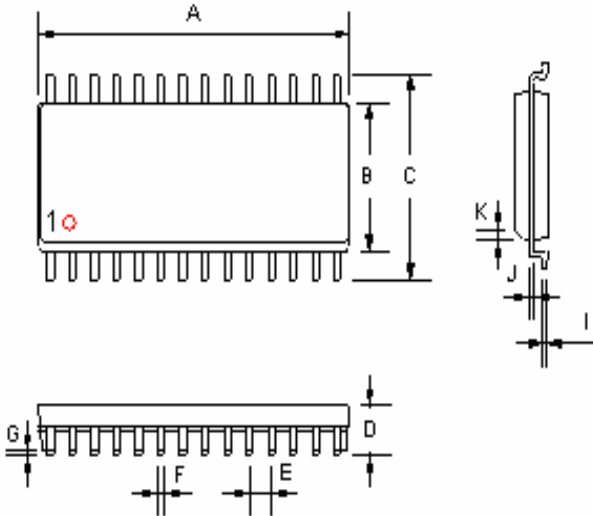

SOP-28 DIMENSION				
DIM	MILLIMETERS		INCHES	
	MIN	MAX	MIN	MAX
A	17.70	18.00	0.697	0.709
B	7.41	7.59	0.292	0.299
C	10.15	10.55	0.400	0.415
D	2.37	2.63	0.093	0.104
E	1.27BSC		0.05BSC	
F	0.40REF		0.016REF	
G	0.10	0.30	0.004	0.012
H	0.60	1.00	0.024	0.040
I	0.25BSC		0.010BSC	
J	0.254TYP		TYP	
K	0.5		0.020	

DIP-28 Mechanical Drawing

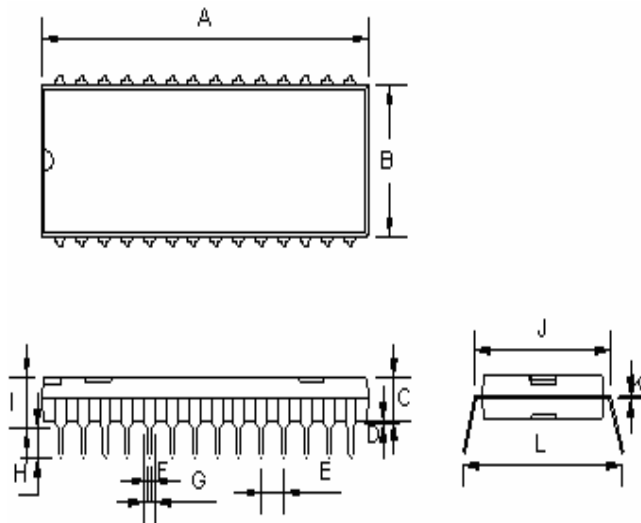

DIP-28 DIMENSION				
DIM	MILLIMETERS		INCHES	
	MIN	MAX	MIN	MAX
A	36.95	37.21	1.455	1.465
B	13.76	14.02	0.542	0.552
C	3.81	4.06	0.15	0.160
D	0.38	--	0.015	--
E	2.54TYP		0.100TYP	
F	0.45TYP		0.018TYP	
G	1.27TYP		0.050TYP	
H	0.119	0.14	3.04	0.31
I	--	5.344	--	0.210
J	14.986	15.49	0.59	0.61
K	0.254NOM		0.010NOM	
L	16.00	17.02	0.589	0.610