

**Adjustable Precision Shunt Regulators**

# TL431N3

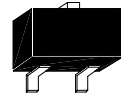

SOT-23

**Description**

The TL431N3 series are three-terminal adjustable regulators with guaranteed thermal stability over applicable temperature range. The output voltage may be set to any value between  $V_{REF}$  (approximately 2.495 volts) and 36 volts with two external resistors. These devices have a typical dynamic output impedance of  $0.2\Omega$ . Active output circuitry provides a very sharp turn-on characteristic, making these devices excellent replacement for zener diodes in many applications.

**Features**

- Programmable output voltage
- Temperature coefficient is 50ppm/°C typical
- Temperature compensated for operation over full temperature range
- Low output noise voltage
- Fast turn on response
- Pb-free package

**Classification**

Rank	A	B	C
$V_{REF}$	$2.495\pm 0.5\%$	$2.495\pm 1\%$	$2.495\pm 2\%$

**Absolute Maximum Ratings**

(Operating temperature range applies unless otherwise specified)

Characteristics	Symbol	Value	Unit
Cathode Voltage	$V_{KA}$	37	V
Cathode Current Range (Continuous)	$I_K$	-100~+150	mA
Reference Input Current Range	$I_{REF}$	0.05~+10	mA
Power Dissipation	$P_D$	300	mW
Operating Temperature Range	$T_{opr}$	-40~+85	°C
Storage Temperature Range	$T_{stg}$	-65~+150	°C

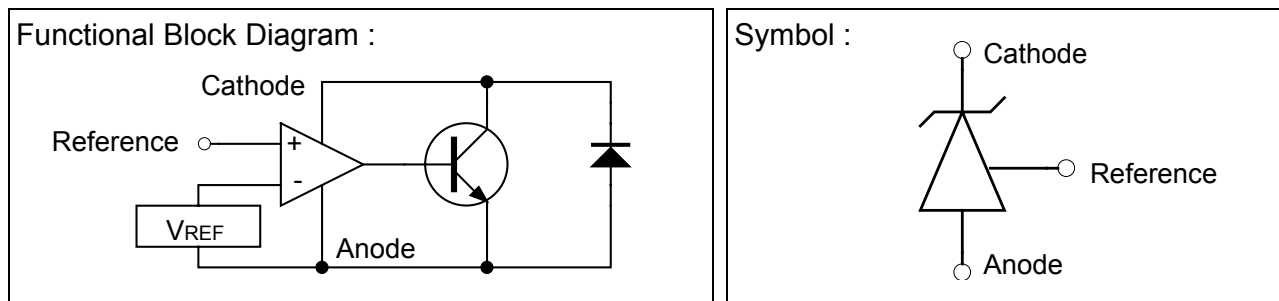
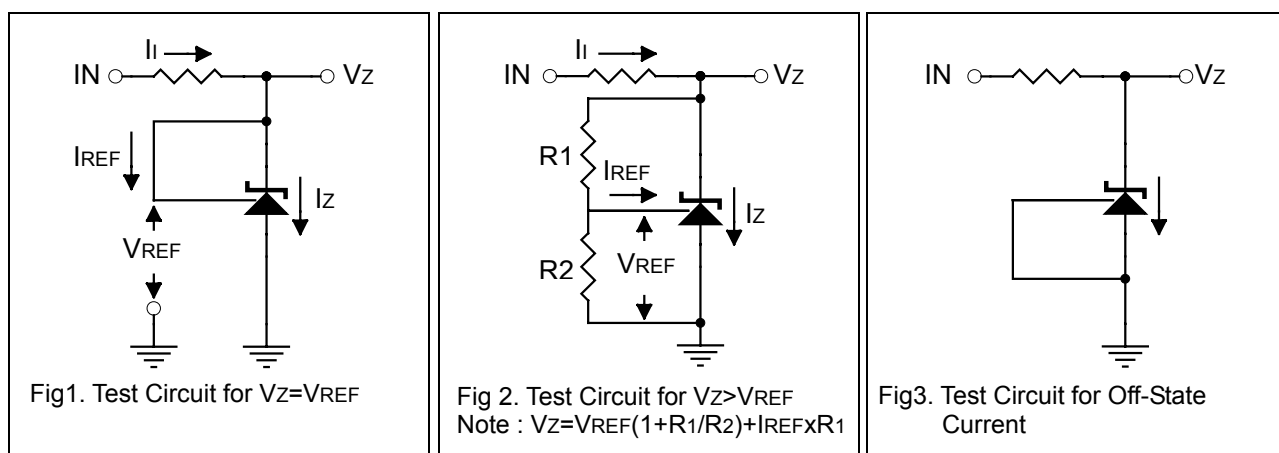
**Functional Block Diagram & Symbol**

**Test Circuits**

**Electrical Characteristics (  $T_a=25^\circ\text{C}$  unless otherwise specified )**

Characteristics	Symbol	Test Conditions	Min	Typ	Max	Unit
Reference Input Voltage TL431A TL431B TL431C	$V_{REF}$	$V_{KA}=V_{REF}, I_K=10\text{mA}$	2.480 2.470 2.445	2.495 2.495 2.495	2.510 2.520 2.545	V
Deviation of Reference Input Voltage Over-Temperature	$V_{REF(\text{dev})}$	$V_{KA}=V_{REF}, I_K=10\text{mA}$ $T_{\text{min}} \leq T_a \leq T_{\text{max}}$	-	4	17	mV
Ratio of Change in Reference Input Voltage to the Change in Cathode Voltage	$\Delta V_{REF} / \Delta V_{KA}$	$I_K=10\text{mA},$ $\Delta V_{KA}=10\text{V}-V_{REF}$	-	-1.4	-2.7	mV
		$I_K=10\text{mA},$ $\Delta V_{KA}=36\text{V}-10\text{V}$	-	-1.0	-2.0	V
Reference Input Current	$I_{REF}$	$I_K=10\text{mA}, R_1=10\text{k}\Omega,$ $R_2=\infty$	-	2	4	$\mu\text{A}$
Deviation of Reference Input Current Over Full Temperature Range	$I_{REF(\text{dev})}$	$I_K=10\text{mA}, R_1=10\text{k}\Omega,$ $R_2=\infty, T_a=\text{Full Range}$	-	0.4	1.2	$\mu\text{A}$
Minimum Cathode Current for Regulation	$I_{K(\text{min})}$	$V_{KA}=V_{REF}$	-	0.4	1.0	mA
Off-State Cathode Current	$I_{K(\text{off})}$	$V_{KA}=36\text{V}, V_{REF}=0$	-	0.1	1.0	$\mu\text{A}$
Dynamic impedance	$Z_{KA}$	$V_{KA}=V_{REF}, f \leq 1.0\text{KHz}$ $I_K=1 \text{ to } 100\text{mA}$	-	0.2	0.5	$\Omega$

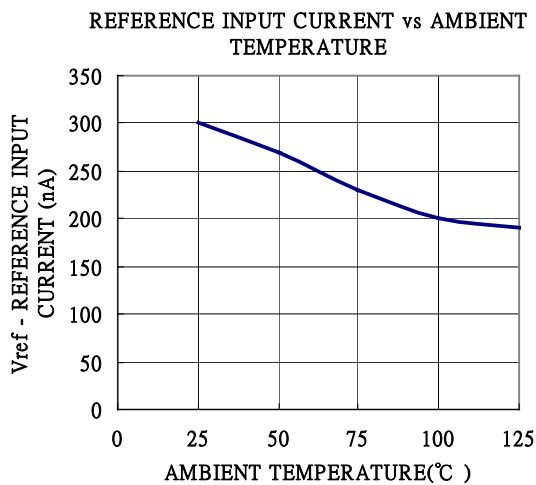
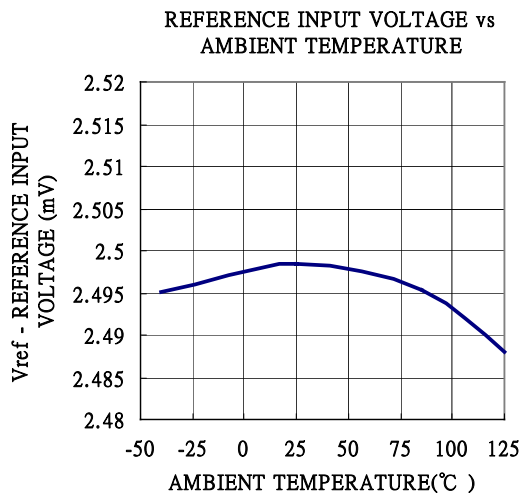
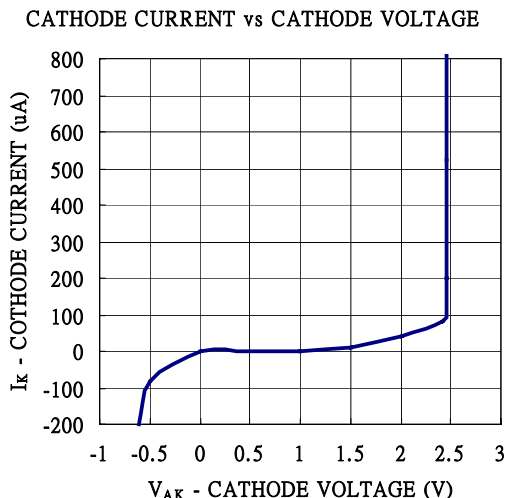
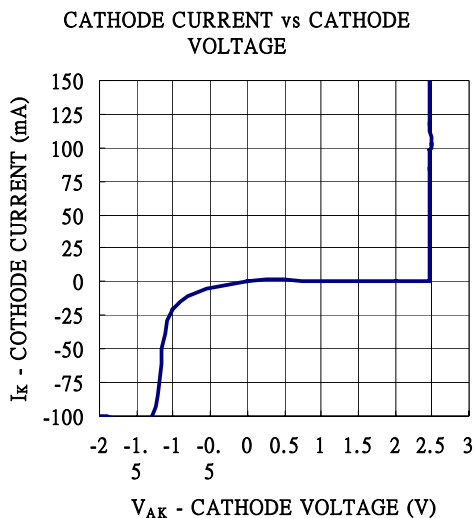

### Characteristic Curves





### Characteristic Curves(Cont.)

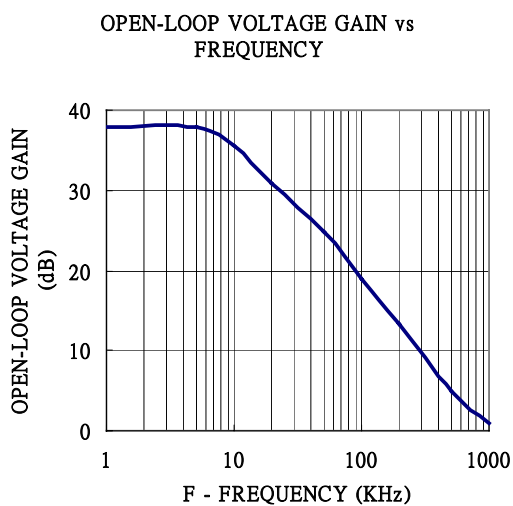
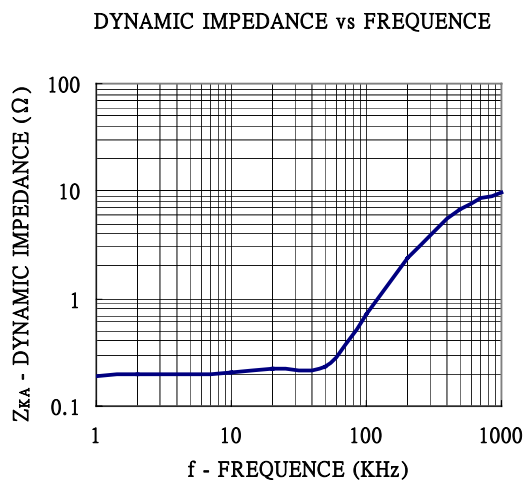
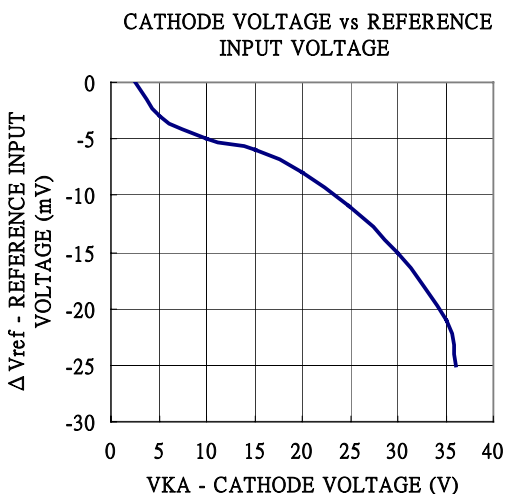

### Ordering Information

Device	Package	Shipping	Marking
TL431N3	SOT-23 (Pb-free)	3000 pcs / Tape & Reel	431

**Recommended wave soldering condition**

Product	Peak Temperature	Soldering Time
Pb-free devices	260 +0/-5 °C	5 +1/-1 seconds

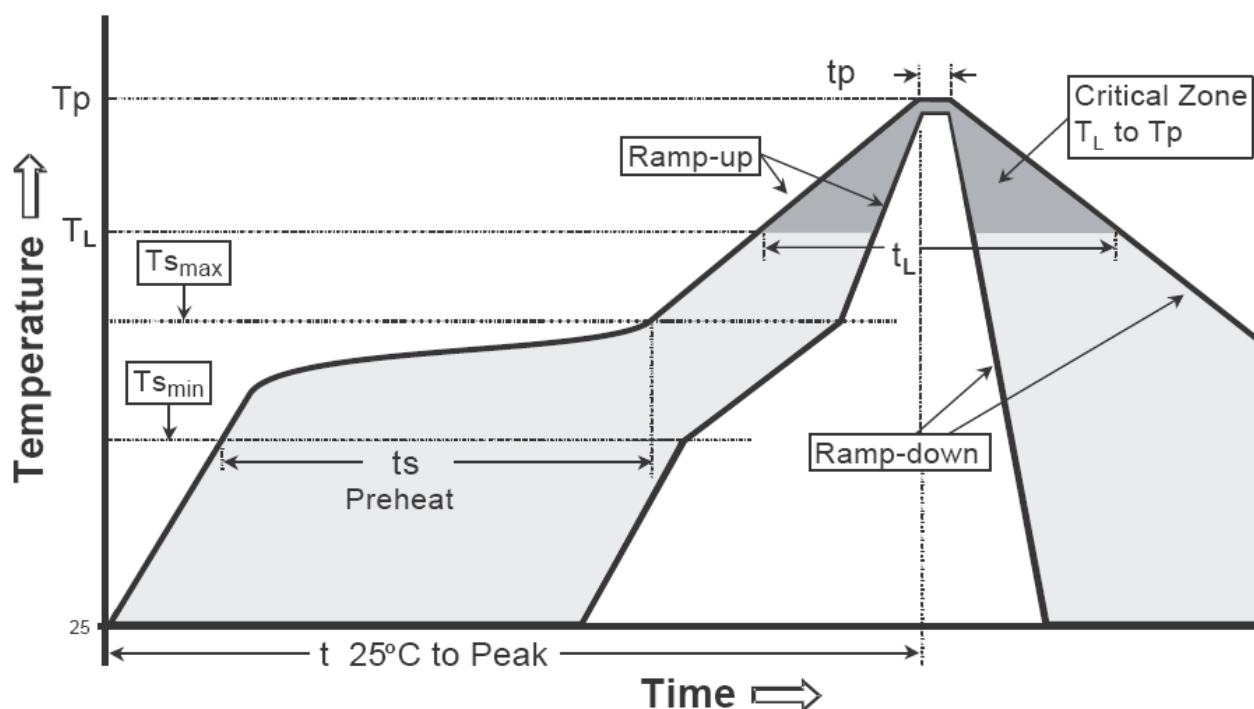
**Recommended temperature profile for IR reflow**

Profile feature	Sn-Pb eutectic Assembly	Pb-free Assembly
Average ramp-up rate (T <sub>smax</sub> to T <sub>p</sub> )	3°C/second max.	3°C/second max.
Preheat		
-Temperature Min(T <sub>s min</sub> )	100°C	150°C
-Temperature Max(T <sub>s max</sub> )	150°C	200°C
-Time(t <sub>s min</sub> to t <sub>s max</sub> )	60-120 seconds	60-180 seconds
Time maintained above:		
-Temperature (T <sub>L</sub> )	183°C	217°C
- Time (t <sub>L</sub> )	60-150 seconds	60-150 seconds
Peak Temperature(T <sub>p</sub> )	240 +0/-5 °C	260 +0/-5 °C
Time within 5°C of actual peak temperature(tp)	10-30 seconds	20-40 seconds
Ramp down rate	6°C/second max.	6°C/second max.
Time 25 °C to peak temperature	6 minutes max.	8 minutes max.

Note : All temperatures refer to topside of the package, measured on the package body surface.

**SOT-23 Dimension**

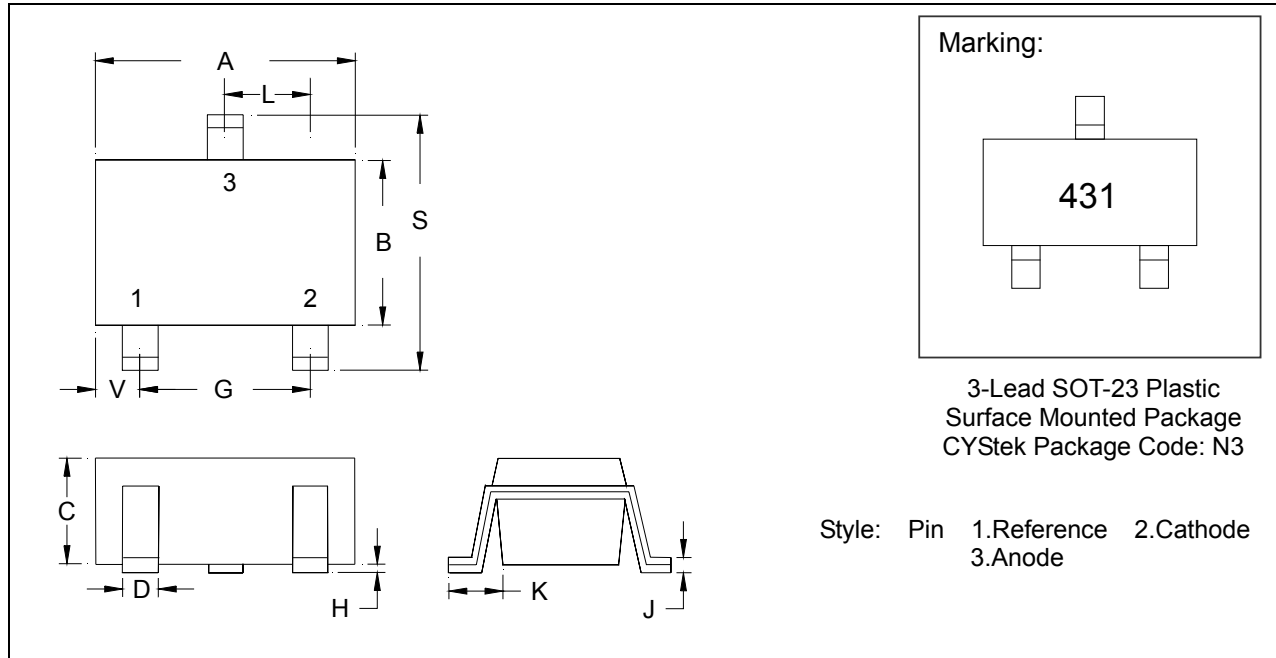

\*: Typical

DIM	Inches		Millimeters		DIM	Inches		Millimeters	
	Min.	Max.	Min.	Max.		Min.	Max.	Min.	Max.
A	0.1102	0.1204	2.80	3.04	J	0.0034	0.0070	0.085	0.177
B	0.0472	0.0630	1.20	1.60	K	0.0128	0.0266	0.32	0.67
C	0.0335	0.0512	0.89	1.30	L	0.0335	0.0453	0.85	1.15
D	0.0118	0.0197	0.30	0.50	S	0.0830	0.1083	2.10	2.75
G	0.0669	0.0910	1.70	2.30	V	0.0098	0.0256	0.25	0.65
H	0.0005	0.0040	0.013	0.10					

**Notes:** 1.Controlling dimension: millimeters.  
 2.Maximum lead thickness includes lead finish thickness, and minimum lead thickness is the minimum thickness of base material.  
 3.If there is any question with packing specification or packing method, please contact your local CYCtek sales office.

**Material:**

- Lead: 42 Alloy; solder plating
- Mold Compound: Epoxy resin family, flammability solid burning class: UL94V-0

**Important Notice:**

- All rights are reserved. Reproduction in whole or in part is prohibited without the prior written approval of CYStek.
- CYStek reserves the right to make changes to its products without notice.
- CYStek **semiconductor products are not warranted to be suitable for use in Life-Support Applications, or systems.**
- CYStek assumes no liability for any consequence of customer product design, infringement of patents, or application assistance.