

PROGRAMMABLE PRECISION REFERENCES

The TL431Z is three-terminal adjustable shunt regulator with specified thermal stability. The output voltage may be set to any value between V_{REF} (Approx. 2.5V) and 36V with two external resistors. This device has a typical output impedance of 0.2Ω . Active output circuitry provides a very sharp turn-on characteristic, making this device excellent replacement for zener diodes in many application.

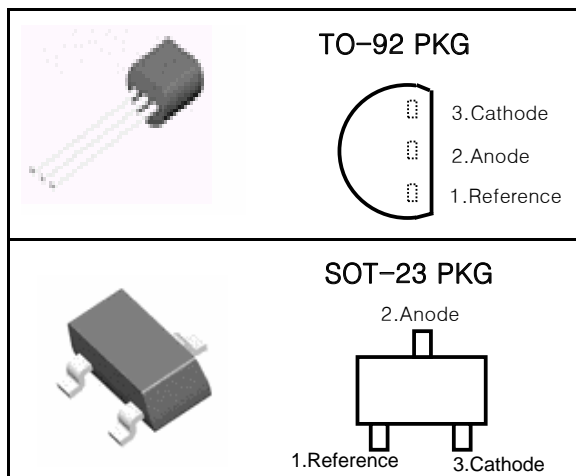

FEATURES

- Equivalent Full Range Temperature Coefficient 50PPM/°C
- Temperature Compensated For Operation Over Full Rate Operating Temperature Range
- Adjustable Output Voltage
- Fast Turn-on Response
- Sink Current Capability 1mA to 100mA
- Low (0.2Ω Typ.) Dynamic Output Impedance
- Low Output Noise

ORDERING INFORMATION

Device	Marking	Package
TL431Z	TL431Z	TO-92
TL431-AZ	TL431-AZ	
TL431-CZ	TL431-CZ	SOT-23
TL431ZSF	431	
TL431-AZSF	* Packing label is different as Vref	
TL431-CZSF		

FUNCTION BLOCK DIAGRAM

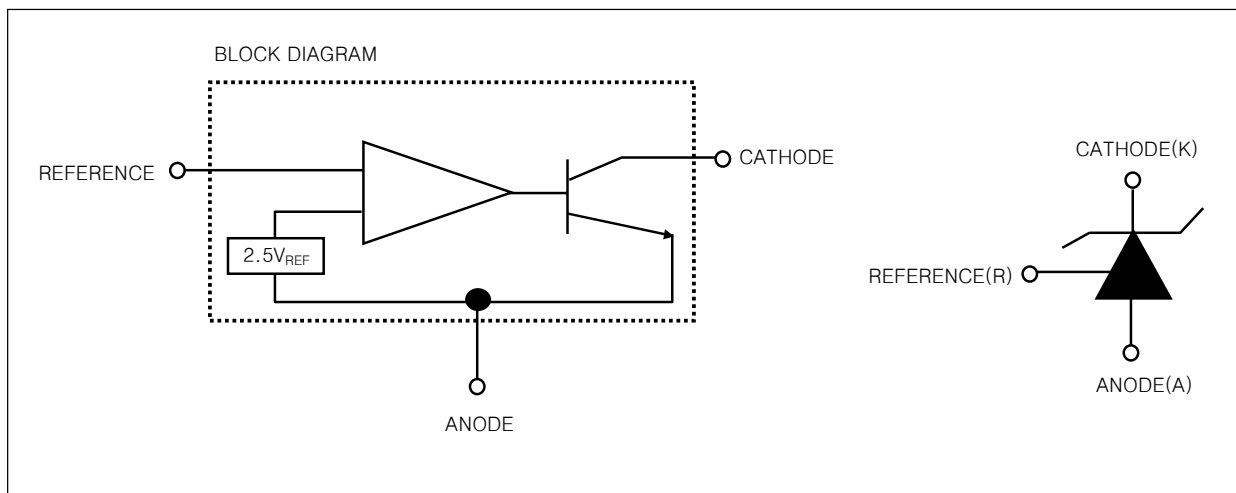

EQUIVALENT SCHEMATIC

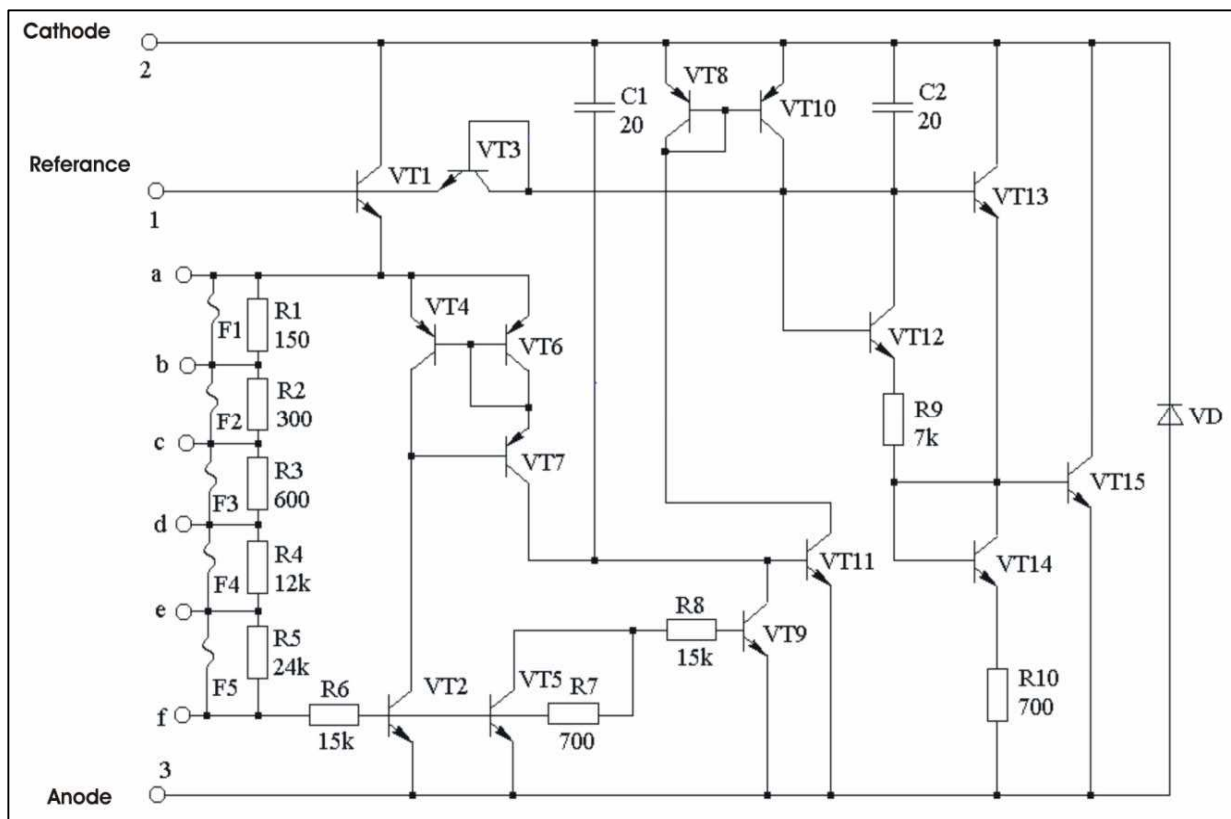

- All component values are nominal

RECOMMENDED OPERATING CONDITIONS

CHARACTERISTIC	SYMBOL	MIN.	MAX.	UNIT
Cathode Voltage	V_{KA}	V_{REF}	36	V
Cathode Current	I_K	1	100	mA

DISSIPATION RATING TABLE1-FREE-AIR TEMPERATURE

Package	$T_A=25^\circ\text{C}$ Power Rating	Derating Factor Above $T_A=25^\circ\text{C}$	$T_A=70^\circ\text{C}$ Power Rating	$T_A=85^\circ\text{C}$ Power Rating	$T_A=125^\circ\text{C}$ Power Rating
TO-92	770mW	6.2mW/ $^\circ\text{C}$	491mW	398mW	-
SOT-23	230mW	1.8mW/ $^\circ\text{C}$	149mW	122mW	-

PROGRAMMABLE PRECISION SHUNT REGULATOR TL431Z/AZ /CZ

ABSOLUTE MAXIMUM RATINGS

(Full Operating Ambient Temperature Range Applies Unless Otherwise Noted)

CHARACTERISTIC	SYMBOL	RATING	UNIT
Cathode Voltage	V_{KA}	37	V
Continuous Cathode Current Range	I_{KA}	-100 ~ +150	mA
Reference Input Current Range	I_{REF}	2 ~ 4	μA
Junction Temperature	T_J	150	$^{\circ}C$
Operating Temperature	T_{OPR}	-40 ~ 85	$^{\circ}C$
Storage Temperature	T_{STG}	-65 ~ 150	$^{\circ}C$
Thermal Resistance Junction to Ambient	Θ_{JA}	TO-92 PKG = 178 SOT-23 PKG = 625	$^{\circ}C/W$

TL431Z ELECTRICAL CHARACTERISTICS

($T_A=25^{\circ}C$, unless otherwise specified)

CHARACTERISTIC	SYMBOL	CIR-CUIT	TEST CONDITION	MIN.	TYP.	MAX.	UNIT
Reference Input Voltage	V_{REF}	1	$V_{KA}=V_{REF}$, $I_K=10mA$	2.440	2.495	2.550	V
Deviation of Reference Input Voltage Over Full Temperature Range	$\Delta V_{REF}/\Delta T$	1	$V_{KA}=V_{REF}$, $I_K=10mA$ $T_A=Full\ Range$		3	17	mV
Ratio of Change in Reference Input Voltage to the Change in Cathode Voltage	$\Delta V_{REF}/\Delta V_{KA}$	2	$I_K=10mA$		-1.4	-2.7	mV/V
			$\Delta V_{KA}=10V-V_{REF}$				
			$\Delta V_{KA}=36V-10V$		-1	-2	
Reference Input Current	I_{REF}	2	$I_{KA}=10mA$, $R1=10k\Omega$, $R2=\infty$		2.0	4	μA
Deviation of Reference Input Current Over Full Temperature Range	$\Delta I_{REF}/\Delta T$	2	$I_K=10mA$, $R1=10k\Omega$, $R2=\infty$ $T_A=Full\ Range$		0.4	1.2	μA
Minimum Cathode Current for Regulation	$I_{KA\ MIN}$	1	$\Delta V_{KA}=V_{REF}$		0.4	1	mA
Off-State Cathode Current	$I_{KA\ OFF}$	3	$V_{KA}=36V$, $V_{REF}=0$		0.1	1	μA
Dynamic Impedance	Z_{KA}	1	$V_{KA}=V_{REF}$, $I_K=1mA\sim 100mA$, $f\leq 1kHz$		0.2	0.5	Ω

PROGRAMMABLE PRECISION SHUNT REGULATOR TL431Z/AZ /CZ

TL431AZ ELECTRICAL CHARACTERISTICS

($T_A=25^{\circ}\text{C}$, unless otherwise specified)

CHARACTERISTIC	SYMBOL	CIR-CUIT	TEST CONDITION	MIN.	TYP.	MAX.	UNIT
Reference Input Voltage	V_{REF}	1	$V_{KA}=V_{REF}$, $I_K=10\text{mA}$	2.470	2.495	2.520	V
Deviation of Reference Input Voltage Over Full Temperature Range	$\Delta V_{REF}/\Delta T$	1	$V_{KA}=V_{REF}$, $I_K=10\text{mA}$ $T_A=\text{Full Range}$		3	17	mV
Ratio of Change in Reference Input Voltage to the Change in Cathode Voltage	$\Delta V_{REF}/\Delta V_{KA}$	2	$I_K=10\text{mA}$	$\Delta V_{KA}=10\text{V}-V_{REF}$	-1.4	-2.7	mV/V
				$\Delta V_{KA}=36\text{V}-10\text{V}$	-1	-2	
Reference Input Current	I_{REF}	2	$I_{KA}=10\text{mA}$, $R1=10\text{k}\Omega$, $R2=\infty$		2.0	4	μA
Deviation of Reference Input Current Over Full Temperature Range	$\Delta I_{REF}/\Delta T$	2	$I_K=10\text{mA}$, $R1=10\text{k}\Omega$, $R2=\infty$ $T_A=\text{Full Range}$		0.4	1.2	μA
Minimum Cathode Current for Regulation	$I_{KA\text{MIN}}$	1	$\Delta V_{KA}=V_{REF}$		0.4	1	mA
Off-State Cathode Current	$I_{KA\text{OFF}}$	3	$V_{KA}=36\text{V}$, $V_{REF}=0$		0.1	1	μA
Dynamic Impedance	Z_{KA}	1	$V_{KA}=V_{REF}$, $I_K=1\text{mA}\sim 100\text{mA}$, $f\leq 1\text{kHz}$		0.2	0.5	Ω

TL431CZ ELECTRICAL CHARACTERISTICS

($T_A=25^{\circ}\text{C}$, unless otherwise specified)

CHARACTERISTIC	SYMBOL	CIR-CUIT	TEST CONDITION	MIN.	TYP.	MAX.	UNIT
Reference Input Voltage	V_{REF}	1	$V_{KA}=V_{REF}$, $I_K=10\text{mA}$	2.482	2.495	2.508	V
Deviation of Reference Input Voltage Over Full Temperature Range	$\Delta V_{REF}/\Delta T$	1	$V_{KA}=V_{REF}$, $I_K=10\text{mA}$ $T_A=\text{Full Range}$		3	17	mV
Ratio of Change in Reference Input Voltage to the Change in Cathode Voltage	$\Delta V_{REF}/\Delta V_{KA}$	2	$I_K=10\text{mA}$	$\Delta V_{KA}=10\text{V}-V_{REF}$	-1.4	-2.7	mV/V
				$\Delta V_{KA}=36\text{V}-10\text{V}$	-1	-2	
Reference Input Current	I_{REF}	2	$I_{KA}=10\text{mA}$, $R1=10\text{k}\Omega$, $R2=\infty$		2.0	4	μA
Deviation of Reference Input Current Over Full Temperature Range	$\Delta I_{REF}/\Delta T$	2	$I_K=10\text{mA}$, $R1=10\text{k}\Omega$, $R2=\infty$ $T_A=\text{Full Range}$		0.4	1.2	μA
Minimum Cathode Current for Regulation	$I_{KA\text{MIN}}$	1	$\Delta V_{KA}=V_{REF}$		0.4	1	mA
Off-State Cathode Current	$I_{KA\text{OFF}}$	3	$V_{KA}=36\text{V}$, $V_{REF}=0$		0.1	1	μA
Dynamic Impedance	Z_{KA}	1	$V_{KA}=V_{REF}$, $I_K=1\text{mA}\sim 100\text{mA}$, $f\leq 1\text{kHz}$		0.2	0.5	Ω

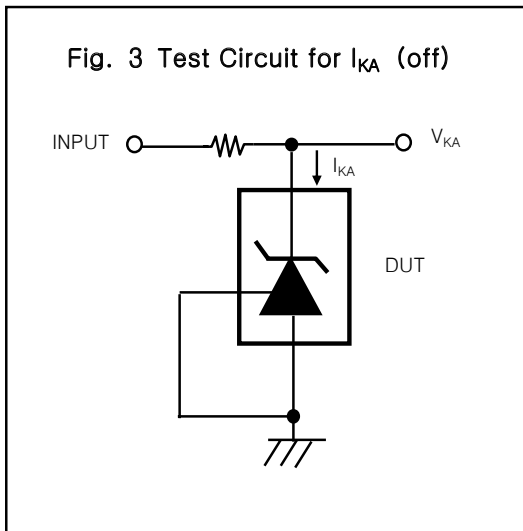
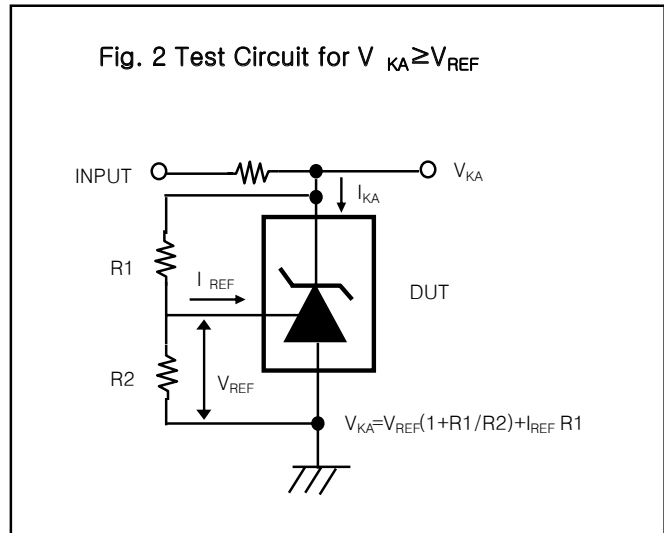
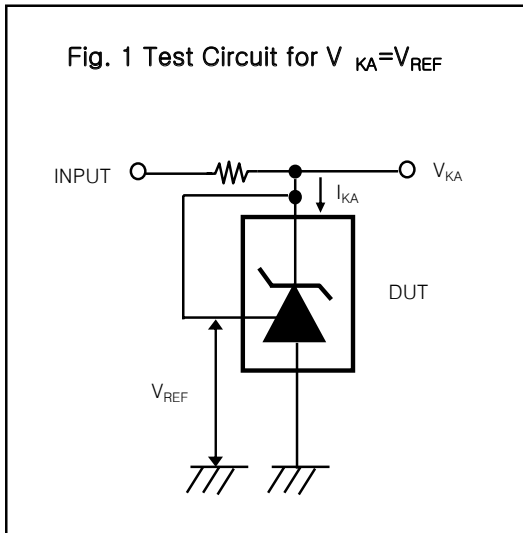

The deviation parameters $V_{REF(DEV)}$ and $I_{REF(DEF)}$ are defined as the differences between the maximum and minimum values obtained over the recommended temperature range. The average full-range temperature coefficient of the reference voltage, αV_{REF} , is defined as :

$$|\alpha V_{REF}| \left(\frac{\text{ppm}}{^\circ\text{C}} \right) = \frac{\left(\frac{V_{I(dev)}}{V_{REF \text{ at } 25^\circ\text{C}}} \right) \times 10^6}{\Delta T_A}$$

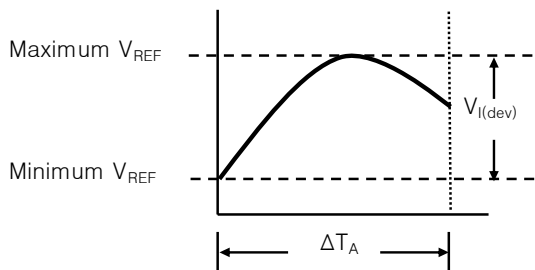

Where :

ΔT_A is the recommended operating free-air temperature range of the device.

αV_{REF} can be positive or negative, depending on whether minimum V_{REF} or maximum V_{REF} , respectively, occurs at the lower temperature.

Example : Maximum $V_{REF}=2496\text{mV}$ at 30°C , minimum $V_{REF}=2492\text{mV}$ at 0°C , $V_{REF}=2495\text{mV}$ at 25°C , $\Delta T_A=70^\circ\text{C}$ for TL431CZ

$$|\alpha V_{REF}| = \frac{\left(\frac{4\text{mV}}{2495\text{mV}} \right) \times 10^6}{70^\circ\text{C}} \approx 23\text{PPM}/^\circ\text{C}$$

Because minimum V_{REF} occurs at the lower temperature, the coefficient is positive.

Calculating Dynamic Impedance

The dynamic impedance is defined as : $|Z_{KA}| = \frac{\Delta V_{KA}}{\Delta I_{KA}}$

When the device is operating with two external resistors (see Figure 3), the total dynamic impedance of the circuit is given by :

$$|Z'| = \frac{\Delta V}{\Delta I} \approx |Z_{KA}| \left(1 + \frac{R1}{R2} \right)$$

Figure 1. Calculating deviation parameters and dynamic impedance

TYPICAL PERFORMANCE CHARACTERISTICS

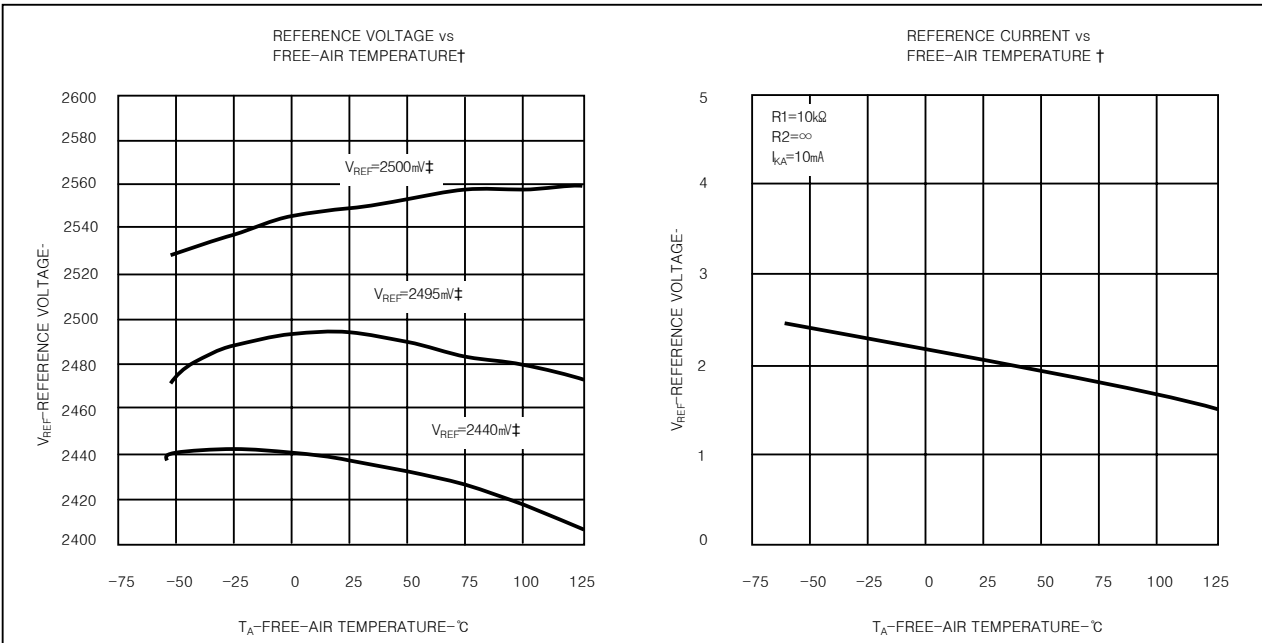

† Data is applicable only within the recommended operating free-air temperature ranges of the various devices.

† Data is applicable only within the recommended operating free-air temperature ranges of the various devices.

‡ Data is for devices having the indicated value of V_{REF} at $I_{KA} = 10\text{mA}$, $T_A = 25^\circ\text{C}$

Figure 4.

Figure 5.

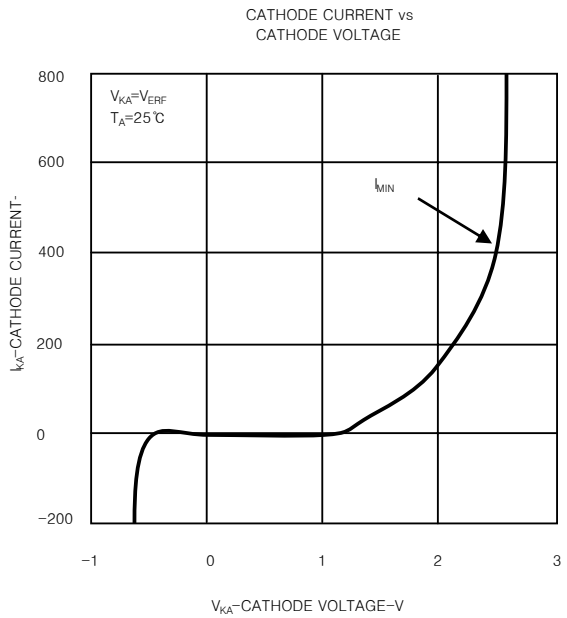
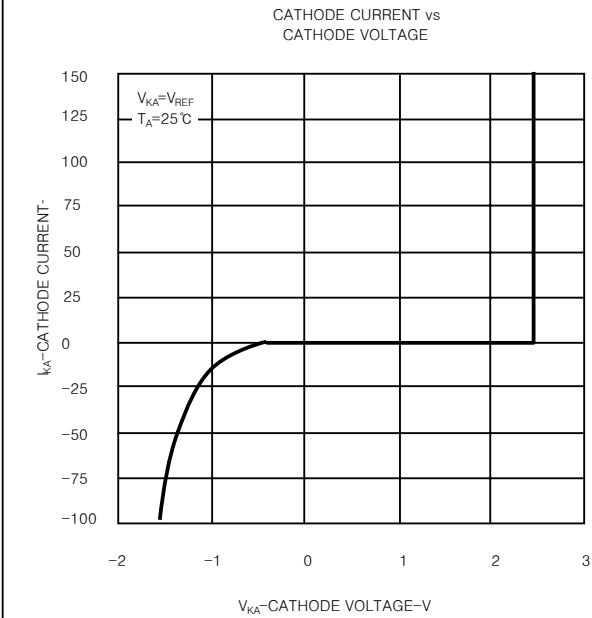
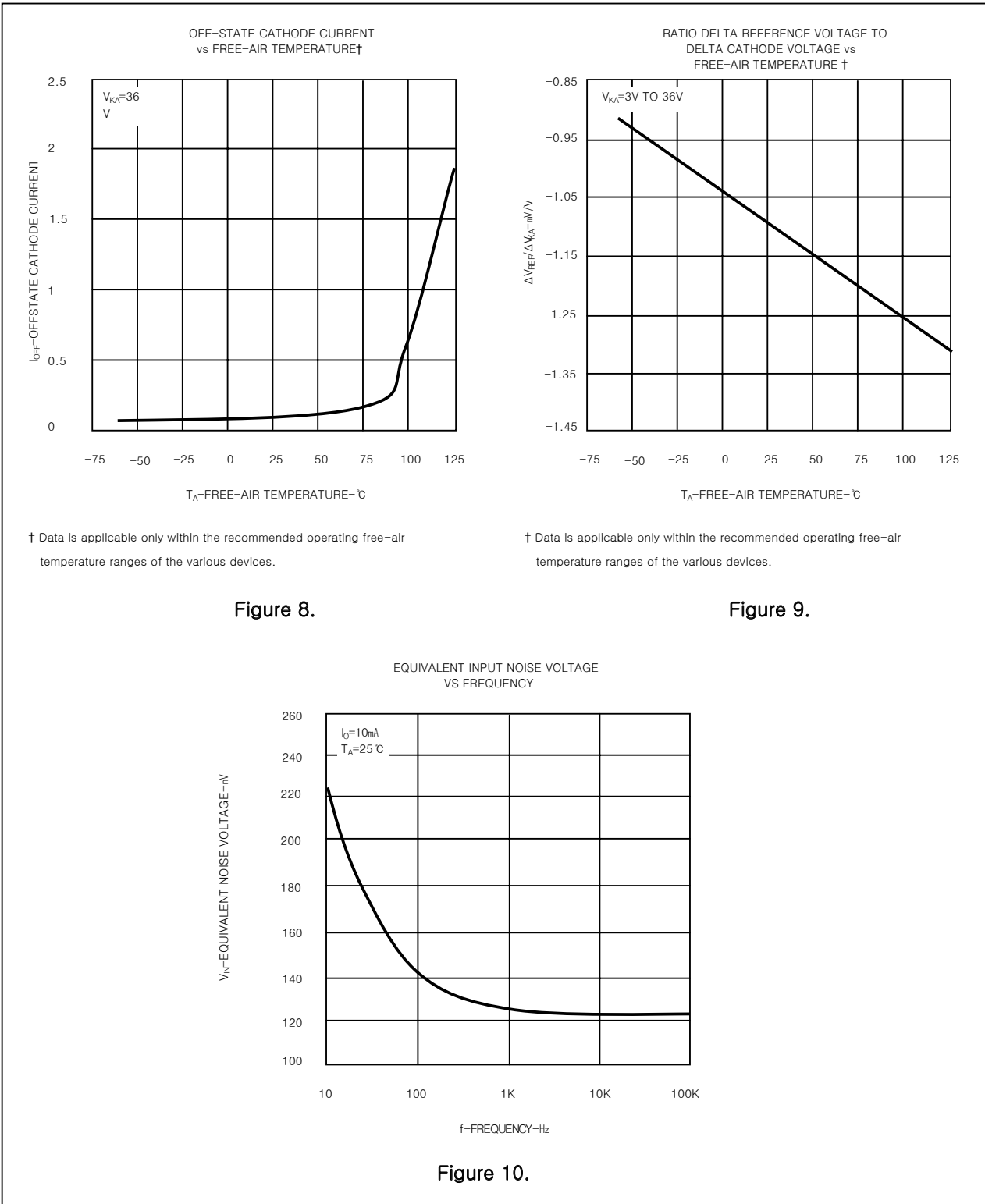

Figure 6.

Figure 7.

TYPICAL PERFORMANCE CHARACTERISTICS



TYPICAL PERFORMANCE CHARACTERISTICS

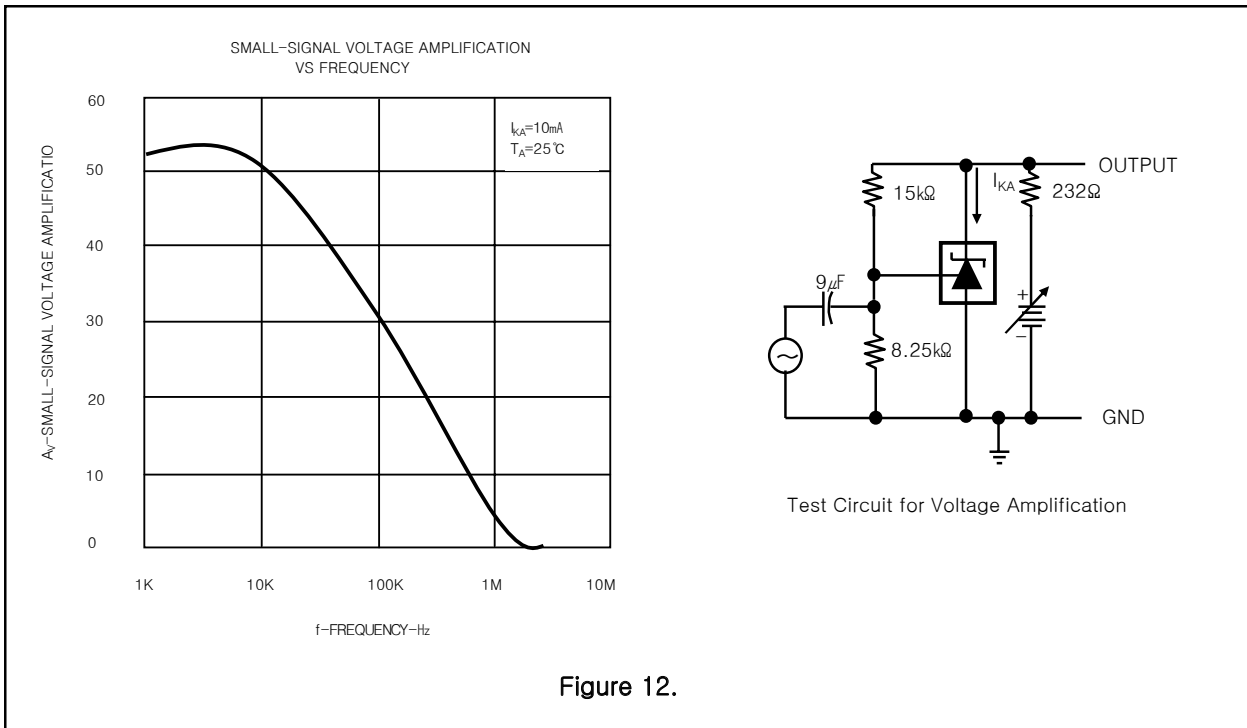
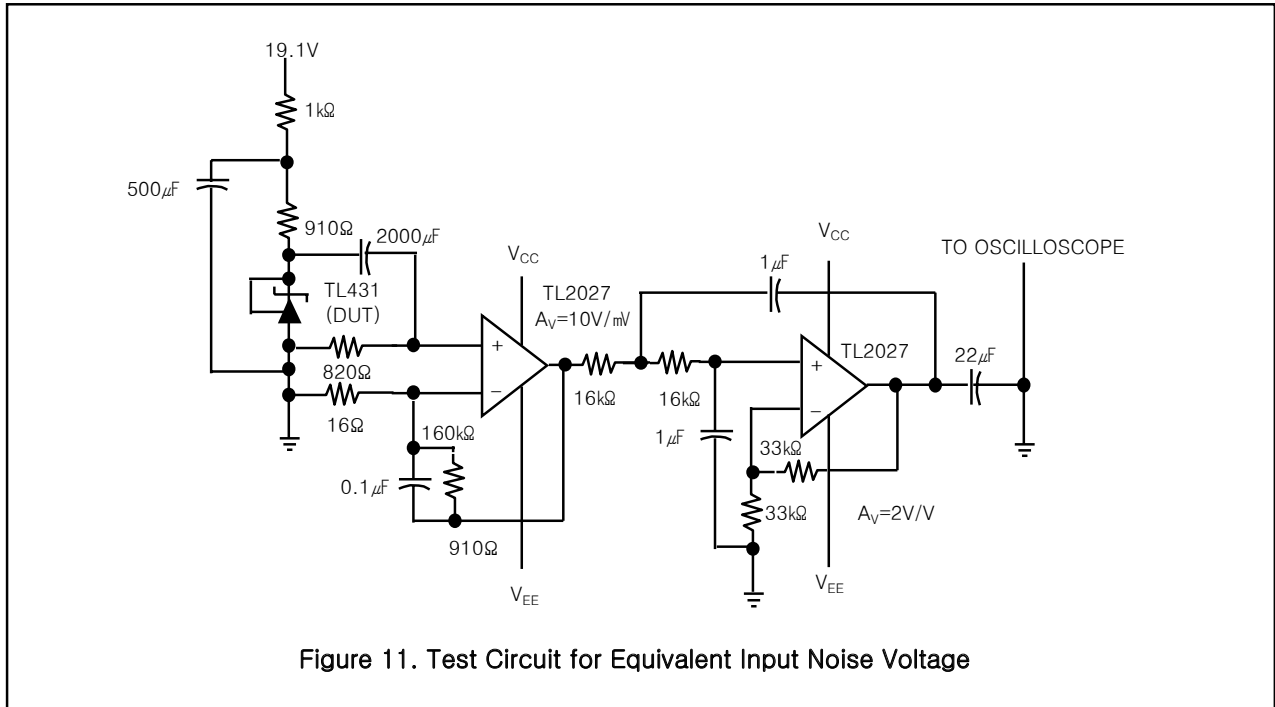

TYPICAL PERFORMANCE CHARACTERISTICS

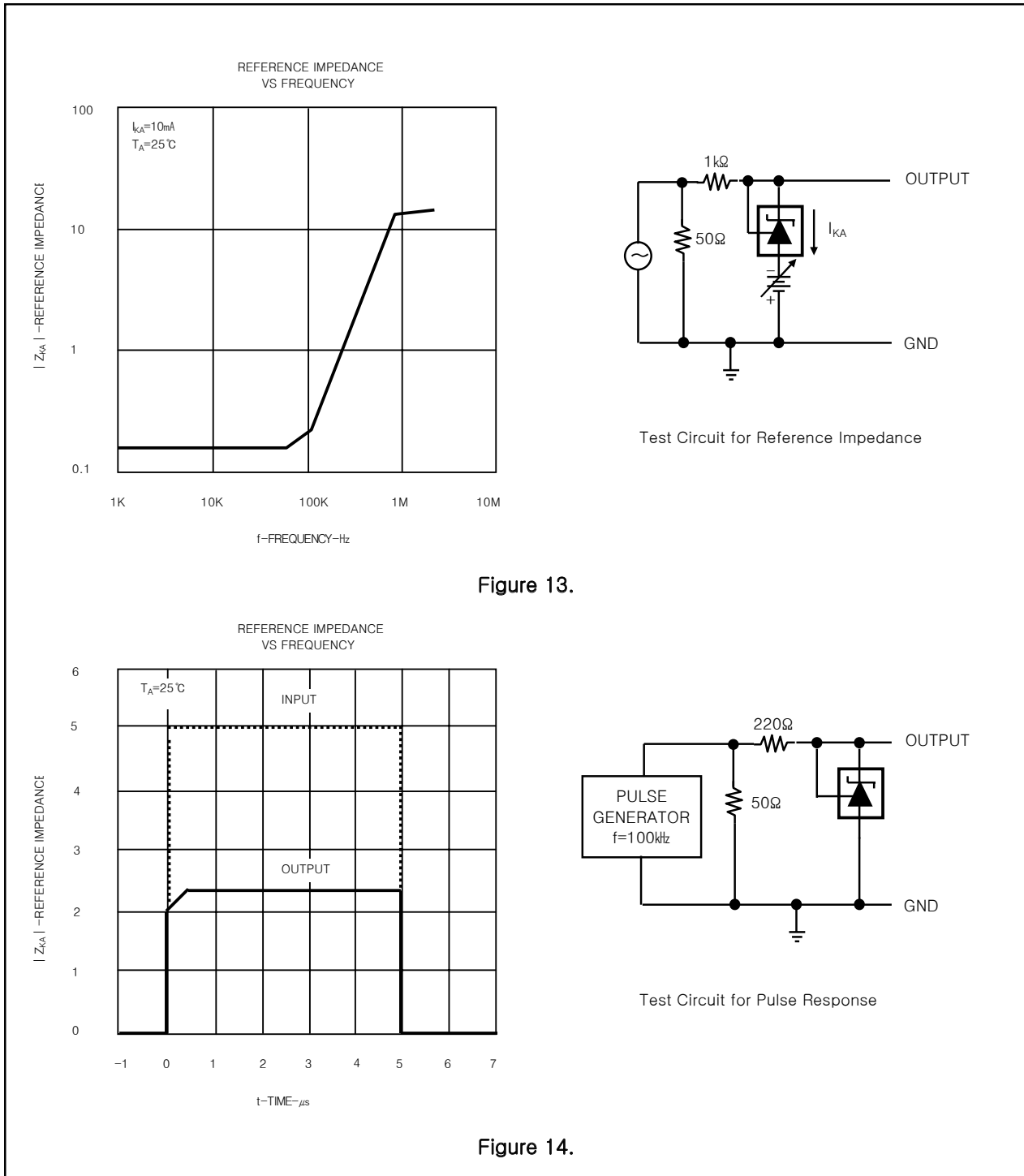
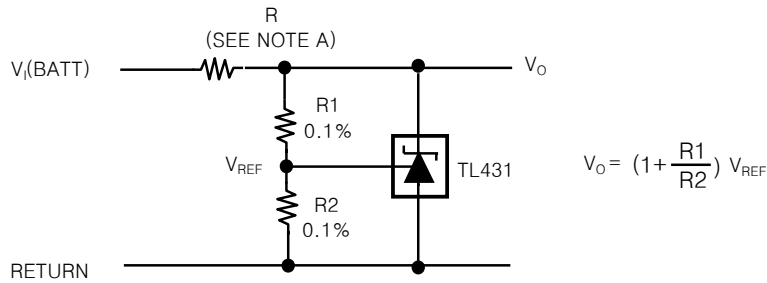

Figure 13.

Figure 14.

APPLICATION INFORMATION



NOTE A : R Should provide cathode current $\geq 1\text{ mA}$ to the TL431 at minimum $V_i(\text{BATT})$

Figure 15. Shunt Regulator

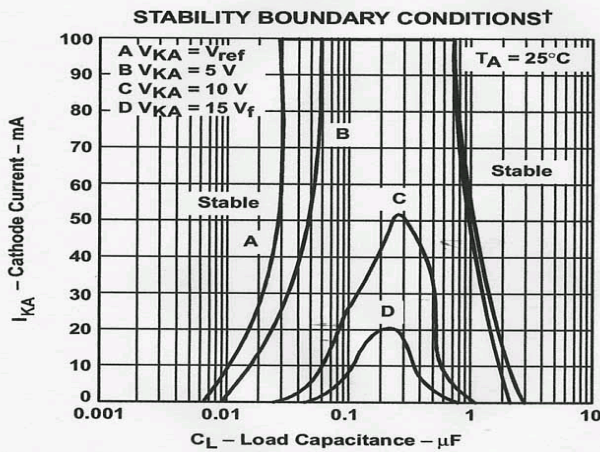

† The areas under the curves represent conditions that may cause the device to oscillate. For curves B, C, and D, R2 and V+ were adjusted to establish the initial V_{KA} and I_{KA} conditions with $C_L = 0$. V_{BATT} and C_L then were adjusted to determine the ranges of stability.

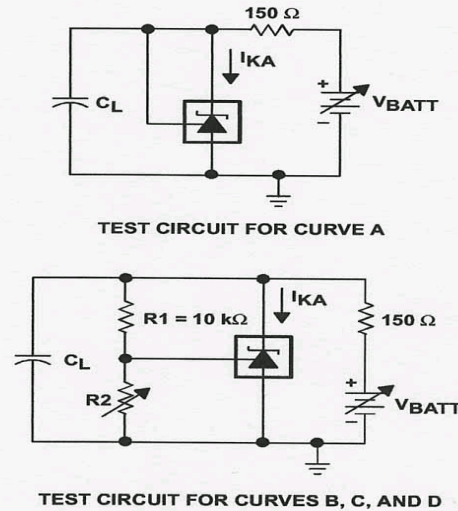
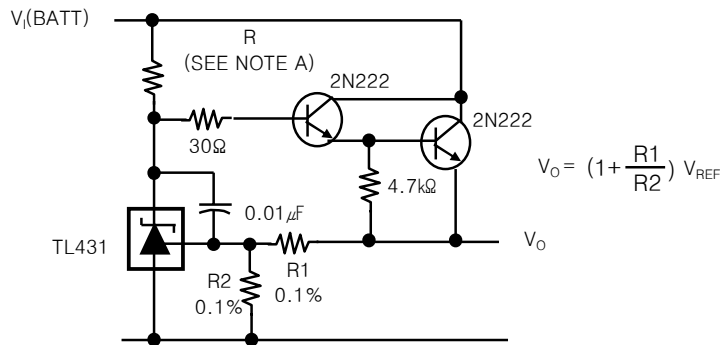

Figure 16



NOTE A : R Should provide cathode current $\geq 1\text{ mA}$ to the TL431 at minimum $V_i(\text{BATT})$

Figure 17. Precision High-Current Series Regulator

APPLICATION INFORMATION

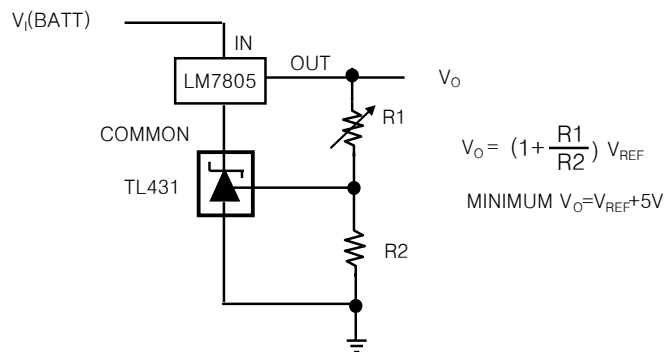

Figure 18. Output Control of a 3-Terminal Fixed Regulator

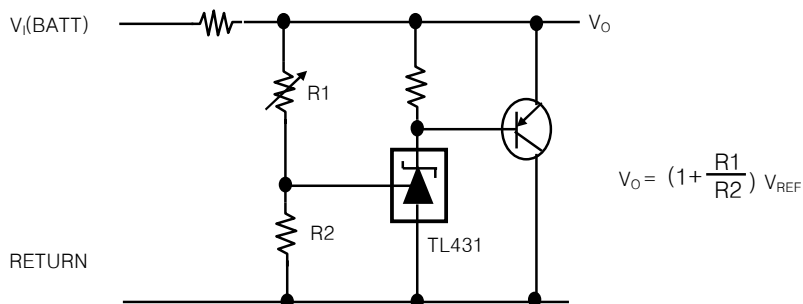
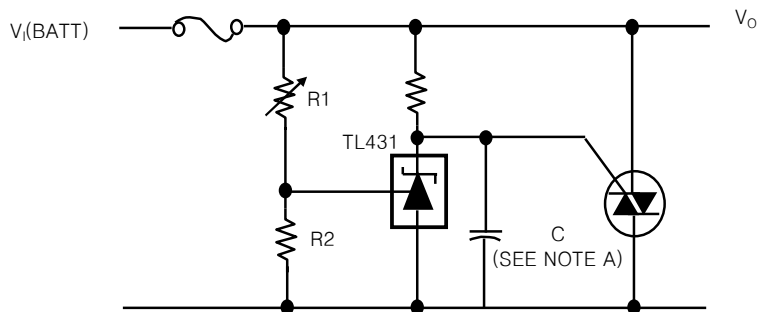

Figure 19. High-Current Shunt Regulator



NOTE A : Refer to the stability boundary conditions in Figure 16 to determine allowable values for C.

Figure 20. Crowbar Circuit

APPLICATION INFORMATION

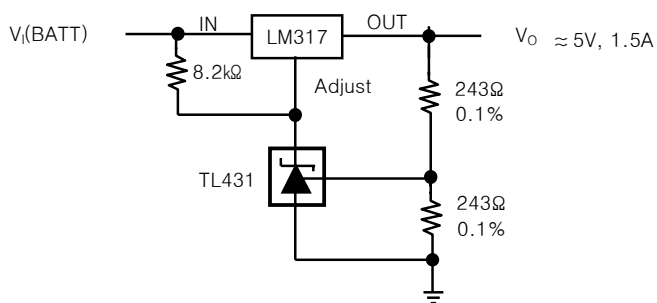
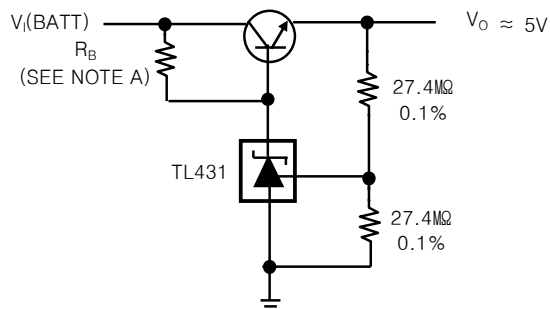

Figure 21. Precision 5-V 1.5A Regulator



NOTE A : R_B Should provide cathode current $\geq 1\text{mA}$ to the TL431.

Figure 22. Efficient 5-V Precision Regulator

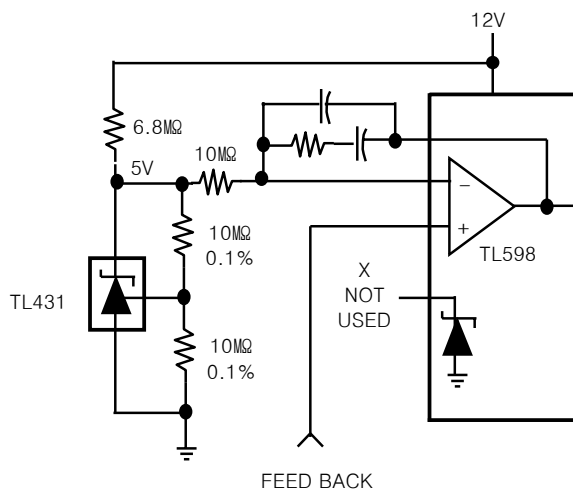
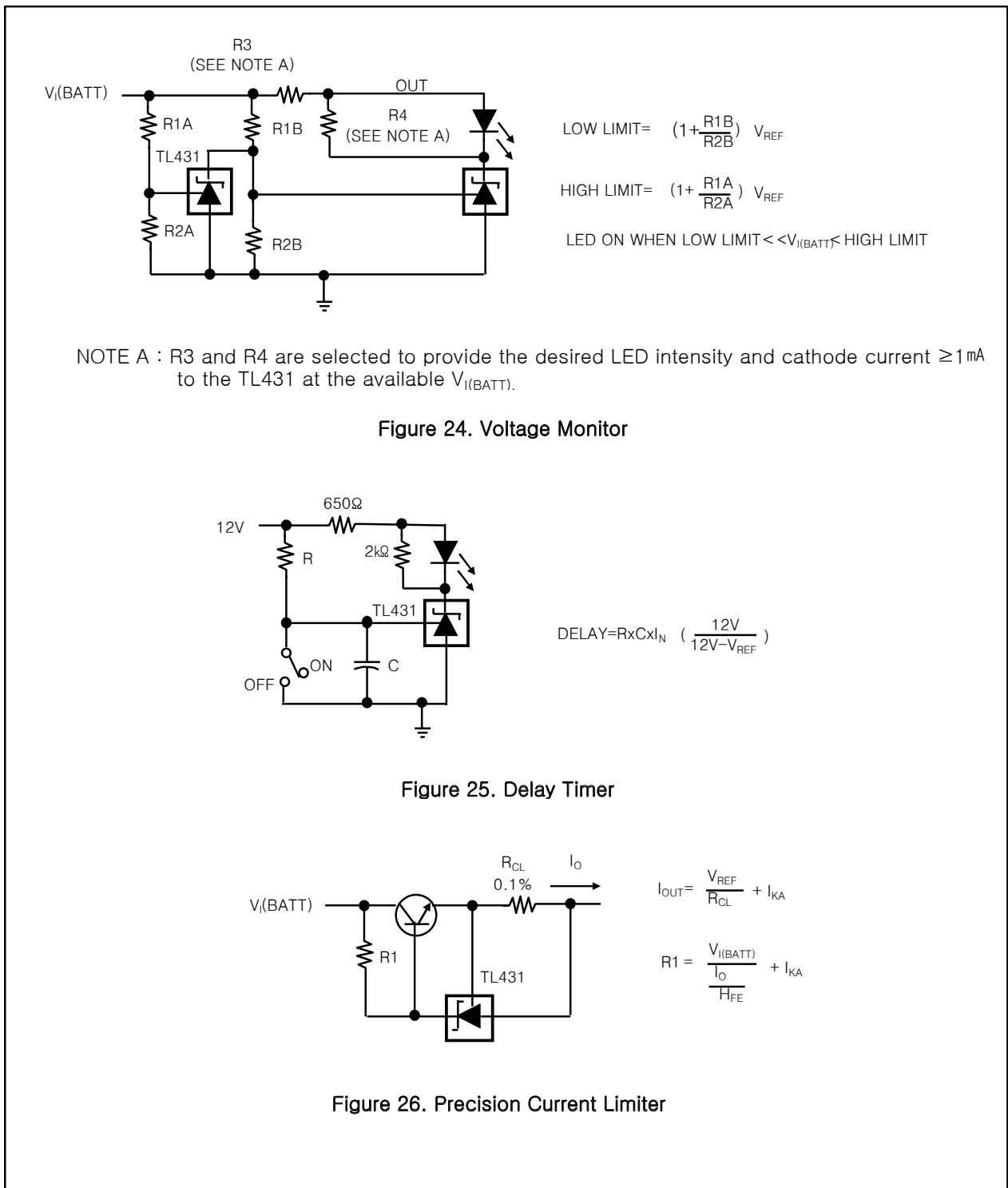

Figure 23. PWM Converter With Reference

APPLICATION INFORMATION



APPLICATION INFORMATION

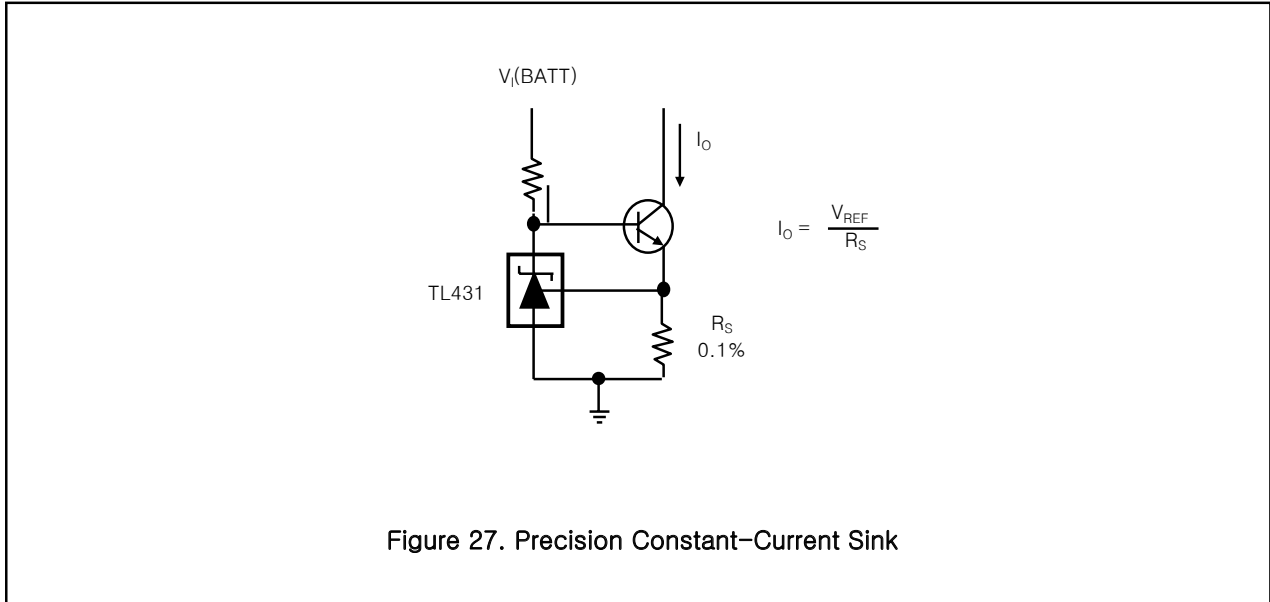

Figure 27. Precision Constant-Current Sink