

400MHz 3-channel Video Amplifier

■ GENERAL DESCRIPTION

The NJM41045 is a wideband 3-channel Video amplifier.
The NJM41045 is suitable for the HD video application because of -3dB large-signal bandwidth of 400MHz.

■ PACKAGE OUTLINE



NJM41045VC3

■ FEATURES

- Operating Voltage (Single) +4.5 to +9.5V
(Dual) ± 3.0 to ± 5.0 V
- Wide Bandwidth -3dB at 400MHz (2Vp-p Output)
- 6dB amplifier
- 75 Ω Driver Circuit
- Power Save Function
- Bipolar Technology
- Package Outline SSOP20-C3

■ PIN CONFIGURATION

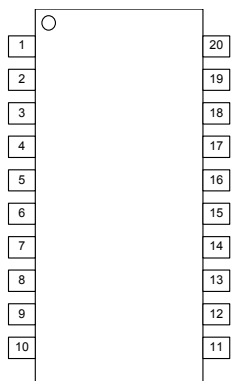

- | | |
|---------------|----------|
| 1. N.C. | 11. V-3 |
| 2. VREF1 | 12. BOUT |
| 3. RIN | 13. V+3 |
| 4. Power save | 14. V-2 |
| 5. VREF2 | 15. GOUT |
| 6. GIN | 16. V+2 |
| 7. GND | 17. V-1 |
| 8. VREF3 | 18. ROUT |
| 9. BIN | 19. V+1 |
| 10. N.C. | 20. N.C. |

■ BLOCK DIAGRAM

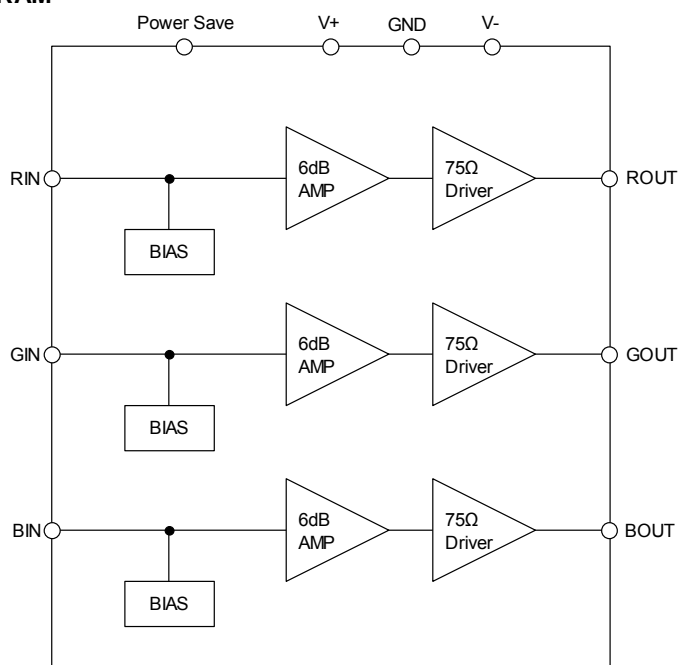

NJM41045

■ ABSOLUTE MAXIMUM RATINGS (Ta=25°C)

PARAMETER	SYMBOL	RATINGS	UNIT
Supply Voltage	V ⁺	10.0	V
Power Dissipation	P _D	1500 ^(Note 1)	mW
Operating Temperature Range	Topr	-40 to +85	°C
Storage Temperature Range	Tstg	-40 to +150	°C

(Note 1) At on a board of EIA/JEDEC specification. (114.3 x 76.2 x 1.6mm 4 layers, FR-4)

■ RECOMMENDED OPEARATING CONDITION (Ta=25°C)

PARAMETER	SYMBOL	TEST CONDITION	MIN.	TYP.	MAX.	UNIT
Operating Voltage1	Vopr1	Single Power Supply	+4.5	-	+9.5	V
Operating Voltage2	Vopr2	Dual Power Supply	±3.0	-	±5.0	V

■ ELECTRICAL CHARACTERISTICS (Ta= 25°C, V⁺ = 5V, R_L = 150Ω)

PARAMETER	SYMBOL	TEST CONDITION	MIN.	TYP.	MAX.	UNIT
Operating Current	I _{CC}	No Signal	-	65	80	mA
Operating Current at Power Save	I _{save}	Power Save Mode	-	0.6	1	mA
Maximum Output Voltage Swing	V _{om}	100kHz, Sine Signal, THD=1%	2.2	2.4	-	Vp-p
Voltage Gain	G _v	1MHz, 1.0Vp-p, Sine Signal	5.5	6.0	6.5	dB
Frequency Characteristic 1	G _{f1}	400MHz/1MHz, 1.0Vp-p, Sine Signal	-	-3.0	-	dB
Frequency Characteristic 2	G _{f2}	450MHz/1MHz, 0.1Vp-p, Sine Signal	-	-3.0	-	dB
Gain Difference Between channel	ΔG _{v1}	1MHz, 1.0Vp-p, Sine Signal ^(Note 2)	-0.25	0	0.25	dB
Differential Gain	DG	V _{in} =1.0Vp-p, 10step Video Signal	-	0.5	-	%
Differential Phase	DP	V _{in} =1.0Vp-p, 10step Video Signal	-	0.5	-	deg
SW Voltage High Level	V _{thH}		2.5	-	V ⁺	V
SW Voltage Low Level	V _{thL}		0	-	1.0	V
Switch Inflow Current High Level	I _{thH}	V _{sw} *=V _{ps} *=5V	-	-	400	μA
Switch Inflow Current Low Level	I _{thL}	V _{sw} *=V _{ps} *=0.3V	-	-	20	μA

(Note 2) Between ROUT/GOUT/BOUT

■ ELECTRICAL CHARACTERISTICS (Ta= 25°C, V^{+/-} = ±5.0V, R_L = 150Ω)

PARAMETER	SYMBOL	TEST CONDITION	MIN.	TYP.	MAX.	UNIT
Operating Current1	I _{CC}	No Signal	-	65	80	mA
Operating Current2	I _{EE}	No Signal	-80	-65	-	mA
Operating Current at Power Save 1	I _{save_1cc}	Power Save Mode	-	0.75	1.3	mA
Operating Current at Power Save 2	I _{save_2ee}	Power Save Mode	-1.4	-0.4	-	mA
Maximum Output Voltage Swing	V _{om}	100kHz, Sine Signal, THD=1%	2.2	2.4	-	Vp-p
Voltage Gain	G _v	1MHz, 1.0Vp-p, Sine Signal	5.5	6.0	6.5	dB
Frequency characteristic 1	G _{f1}	400MHz/1MHz, 1.0Vp-p, Sine Signal	-	-3.0	-	dB
Frequency characteristic 2	G _{f2}	450MHz/1MHz, 0.1Vp-p, Sine Signal	-	-3.0	-	dB
Gain Difference Between channel	ΔG _{v1}	1MHz, 1.0Vp-p, Sine Signal ^(Note 2)	-0.25	0	0.25	dB
Differential Gain	DG	V _{in} =1.0Vp-p, 10step Video Signal	-	0.5	-	%
Differential Phase	DP	V _{in} =1.0Vp-p, 10step Video Signal	-	0.5	-	deg
SW Voltage High Level	V _{thH}		2.5	-	V ⁺	V
SW Voltage Low Level	V _{thL}		0	-	1.0	V
Switch Inflow Current High Level	I _{thH}	V _{sw} *=V _{ps} *=5V	-	-	400	μA
Switch Inflow Current Low Level	I _{thL}	V _{sw} *=V _{ps} *=0.3V	-	-	20	μA

(Note 2) Between ROUT/GOUT/BOUT

■ CONTROL TERMINAL

PARAMETER	STATUS	NOTE
Power Save	H	Power Save: OFF (Active)
	L	Power Save: ON (Mute)
	OPEN	Power Save: ON (Mute)

NJM41045

■ TEST CIRCUIT(SINGLE SUPPLY)

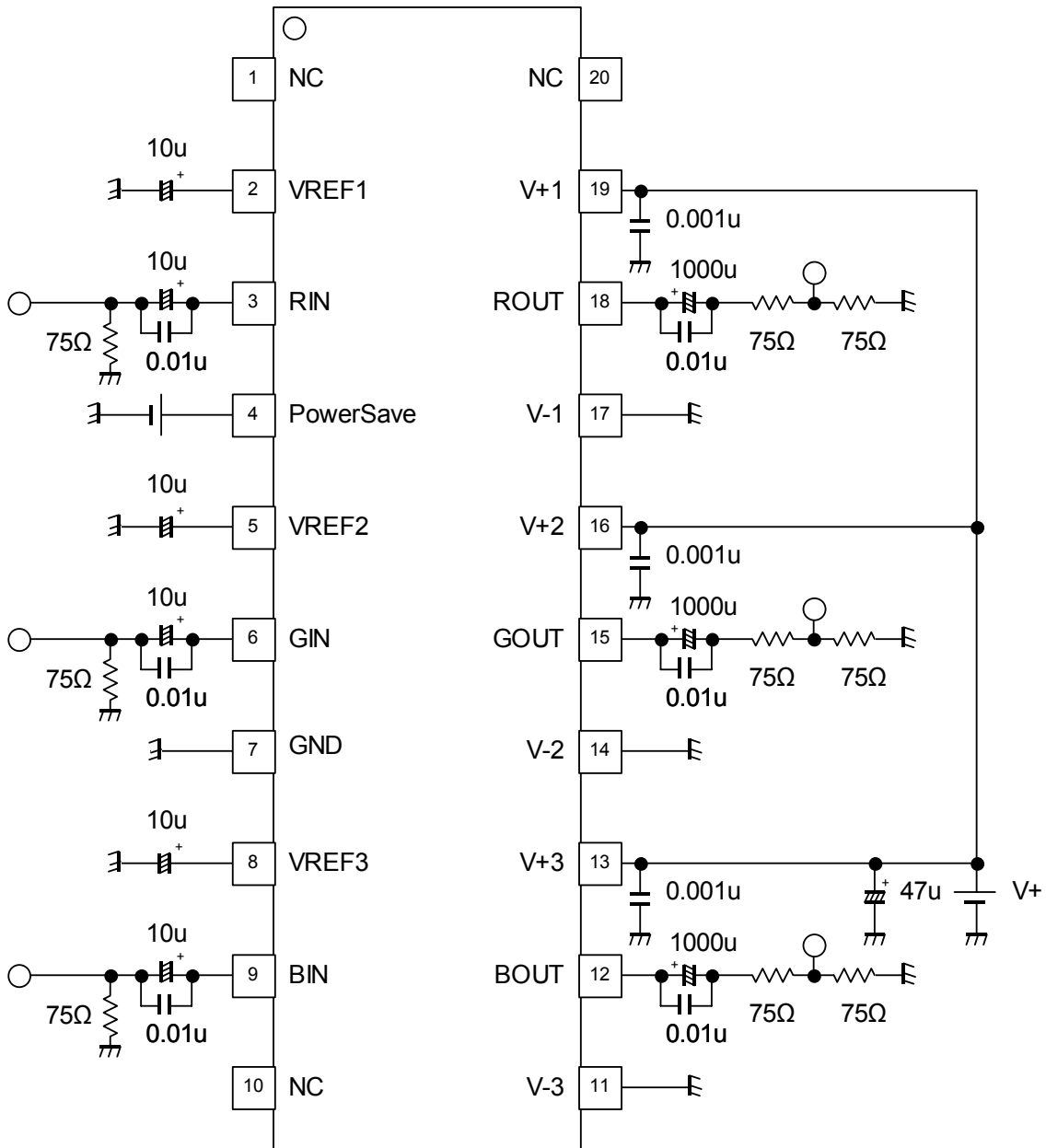

■ TEST CIRCUIT(DUAL SUPPLY)

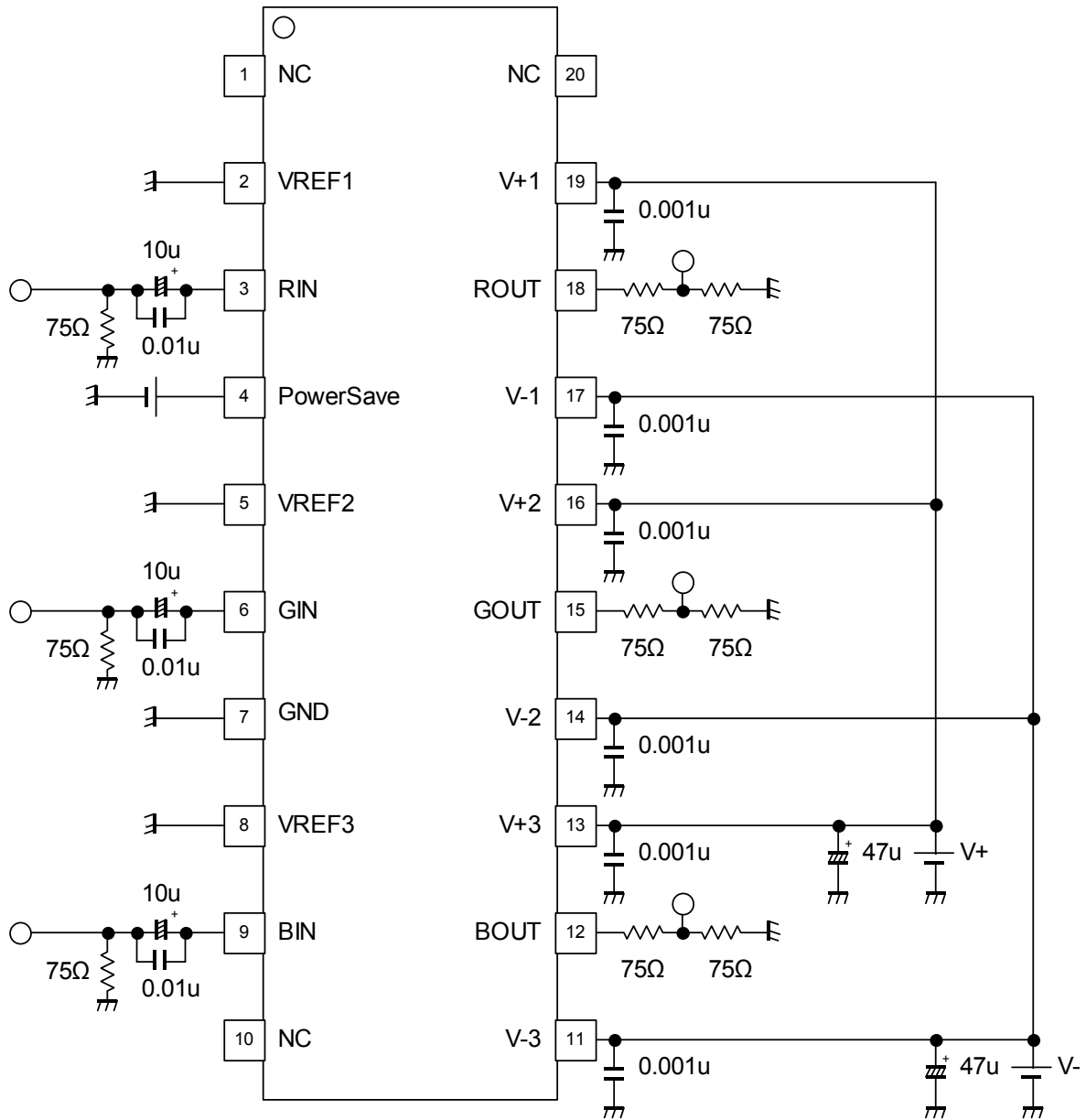

NJM41045

APPLICATION CIRCUIT(SINGLE SUPPLY)

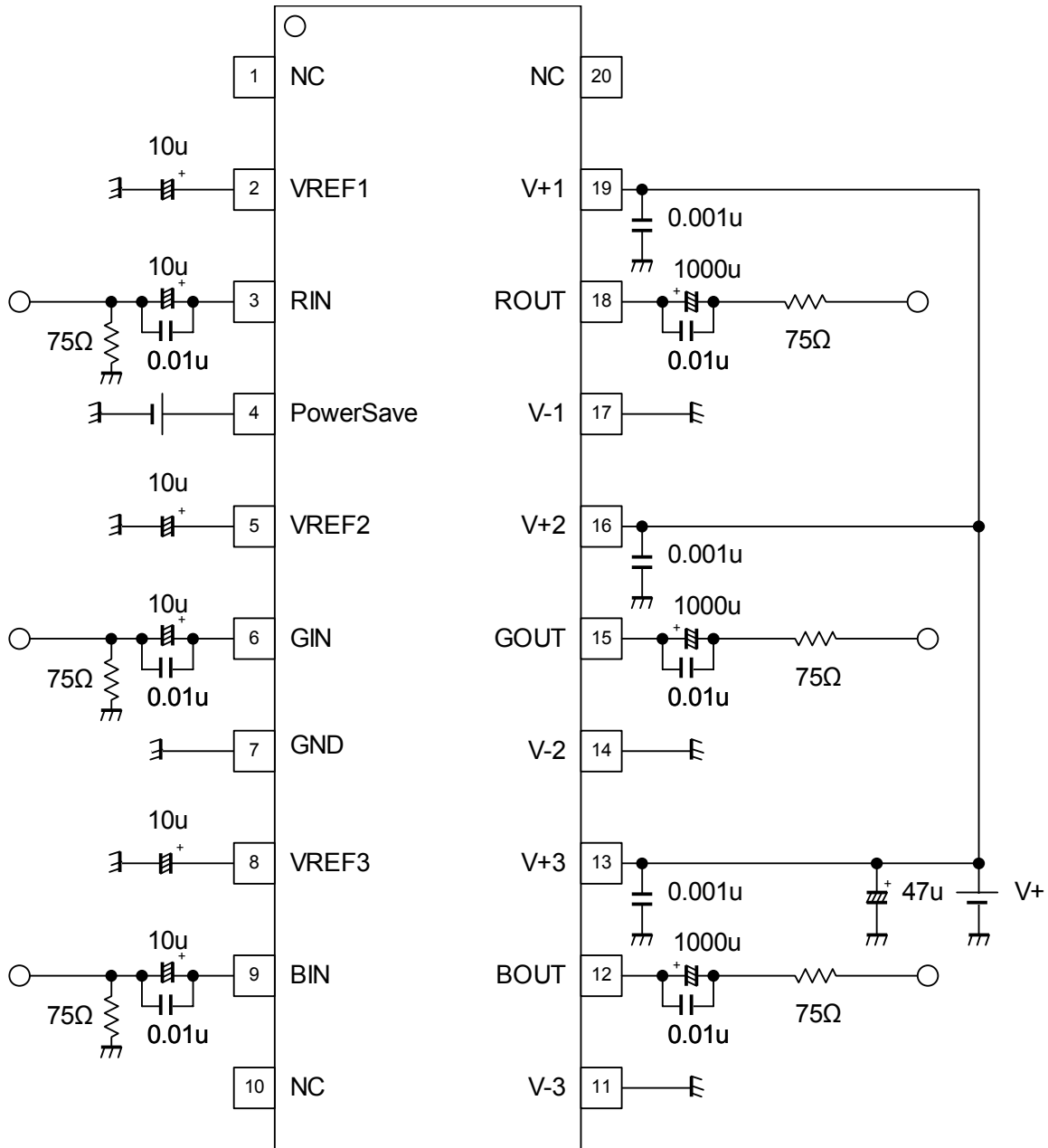

APPLICATION CIRCUIT(DUAL SUPPLY)

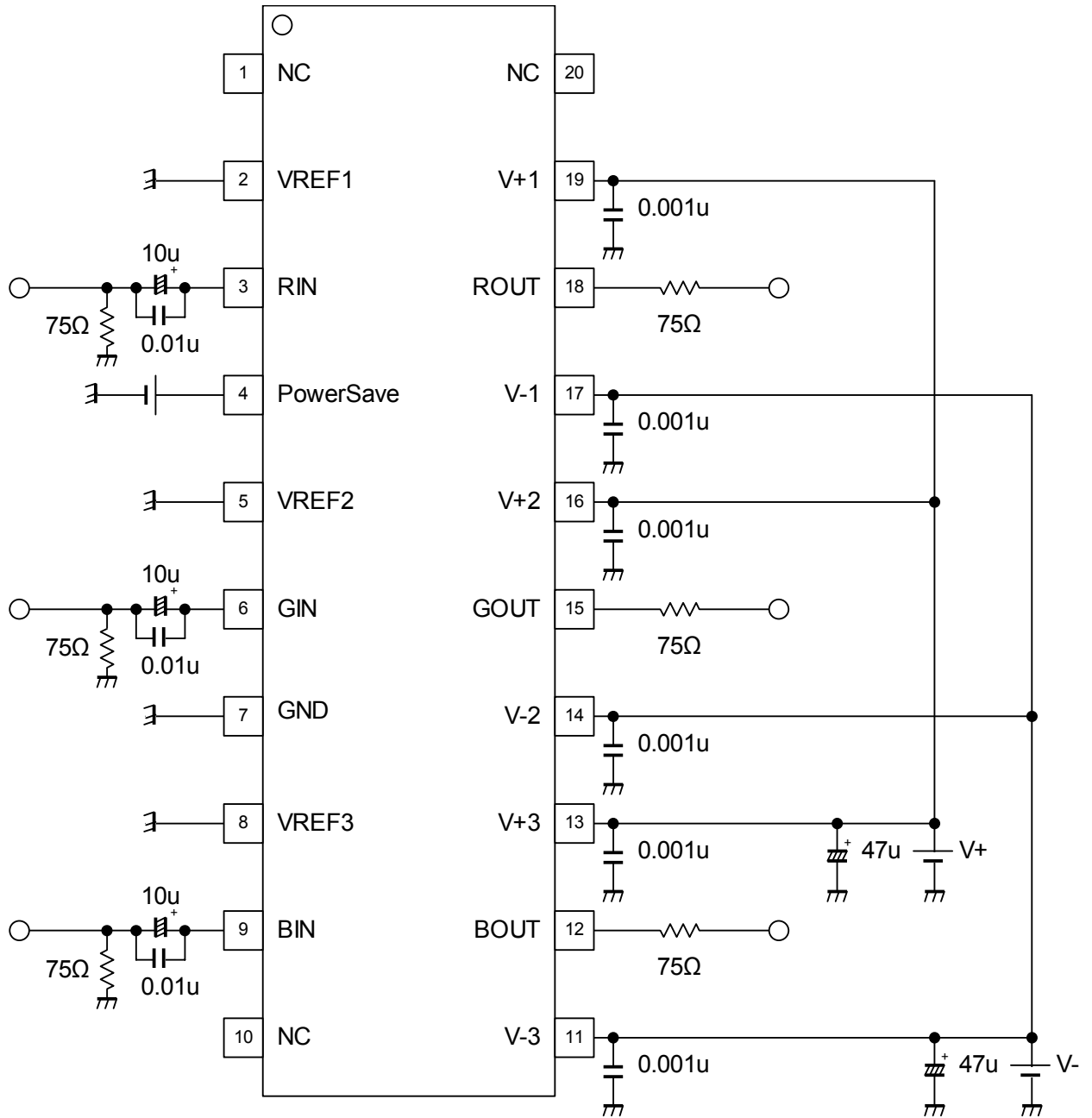

NJM41045

■ TYPICAL CHARACTERISTICS

Voltage Gain vs. Frequency
(Single Supply 1Vpp)

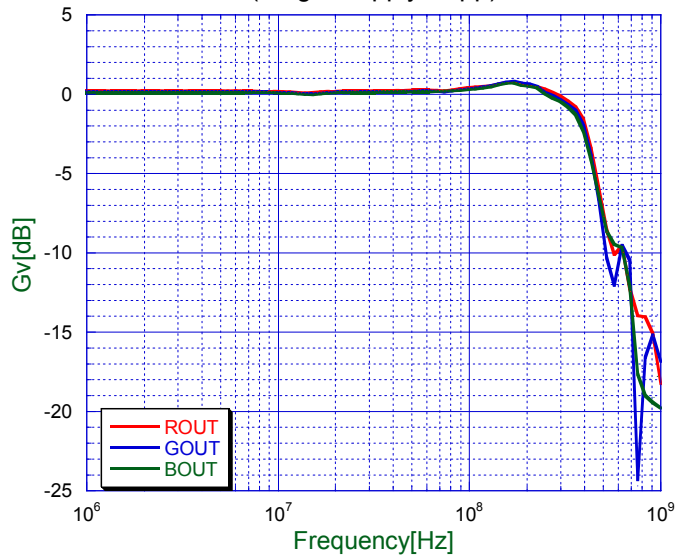

Voltage Gain vs. Frequency
(Dual Supply 1Vpp)

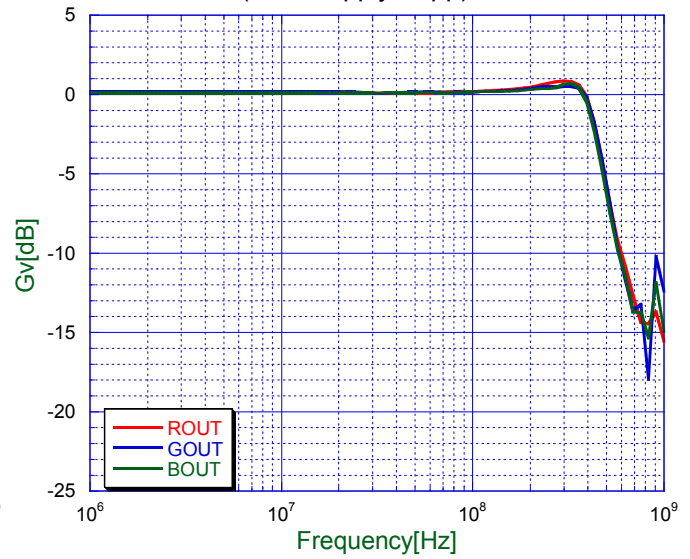

Voltage Gain vs. Frequency
(Single Supply 0.1Vpp)

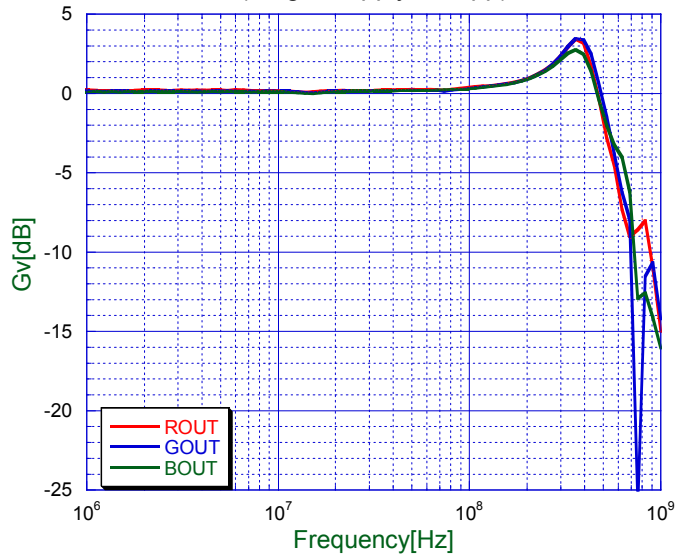

Voltage Gain vs. Frequency
(Dual Supply 0.1Vpp)

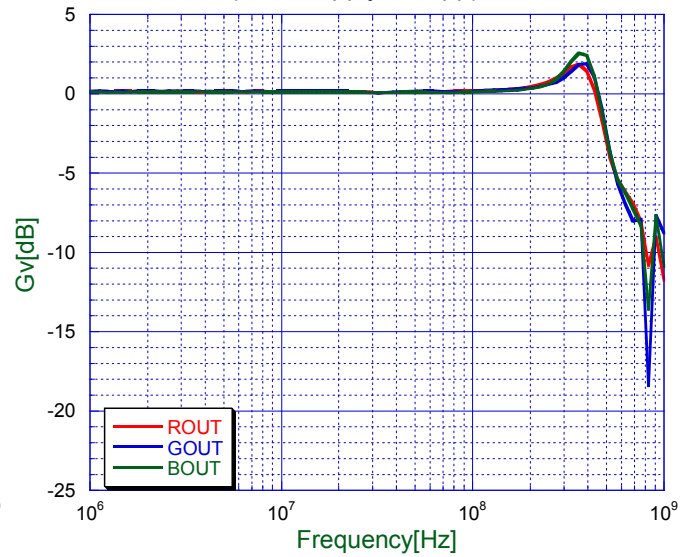

[CAUTION]
The specifications on this databook are only given for information, without any guarantee as regards either mistakes or omissions. The application circuits in this databook are described only to show representative usages of the product and not intended for the guarantee or permission of any right including the industrial rights.