

TOSHIBA CMOS DIGITAL INTEGRATED CIRCUIT SILICON MONOLITHIC

TC9459N, TC9459F

ELECTRONIC VOLUME CONTROL

The TC9459N, TC9459F are electronic volume control ICs developed for use in home stereos and other audio equipment.

Using serial data input from external sources, it controls the sound volume, balance and loudness circuits.

FEATURES

- Sound volume can be controlled in 91 steps from 0 to -89dB or up to an infinite level in 1dB increments.
- Incorporating two channels of volume control circuits, the device allows independent volume control : therefore, it also provides the balancing function.
- A loudness circuit (20dB tap) is built in.
- Can operate with a single or dual power supplies.
- Can control up to 4 chips on the same bus by using chip select input.
- Thanks to its polysilicon resistor, the device allows you to configure a low-distortion, high-performance volume control system.

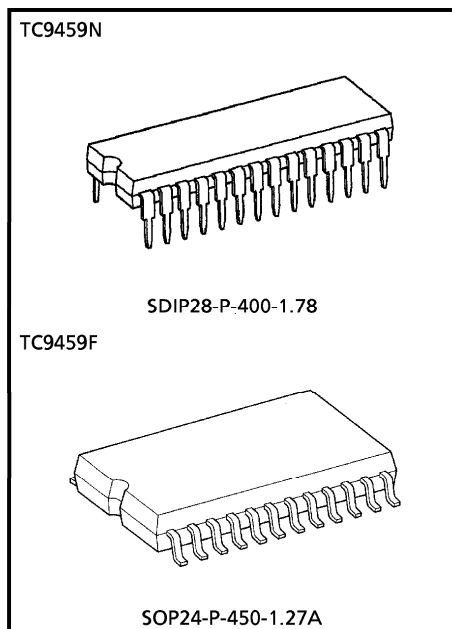

Weight
SDIP28-P-400-1.78 : 2.2g (Typ.)
SOP24-P-450-1.27A : 0.44g (Typ.)

PIN CONNECTIONS

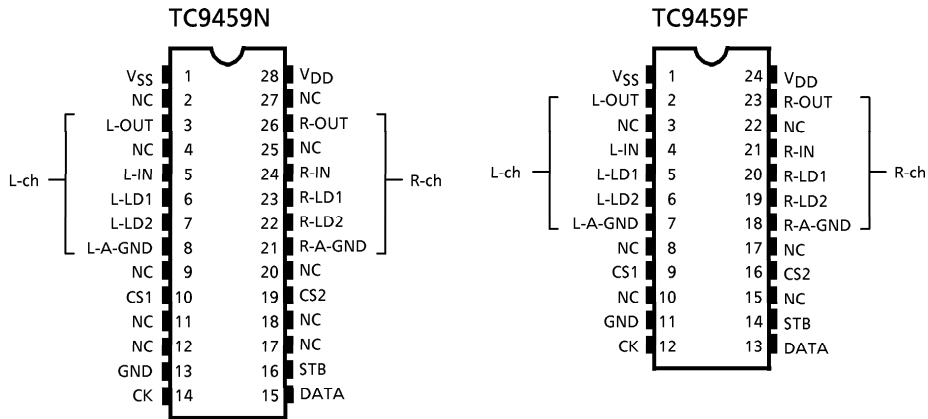

BLOCK DIAGRAM (TC9459N)

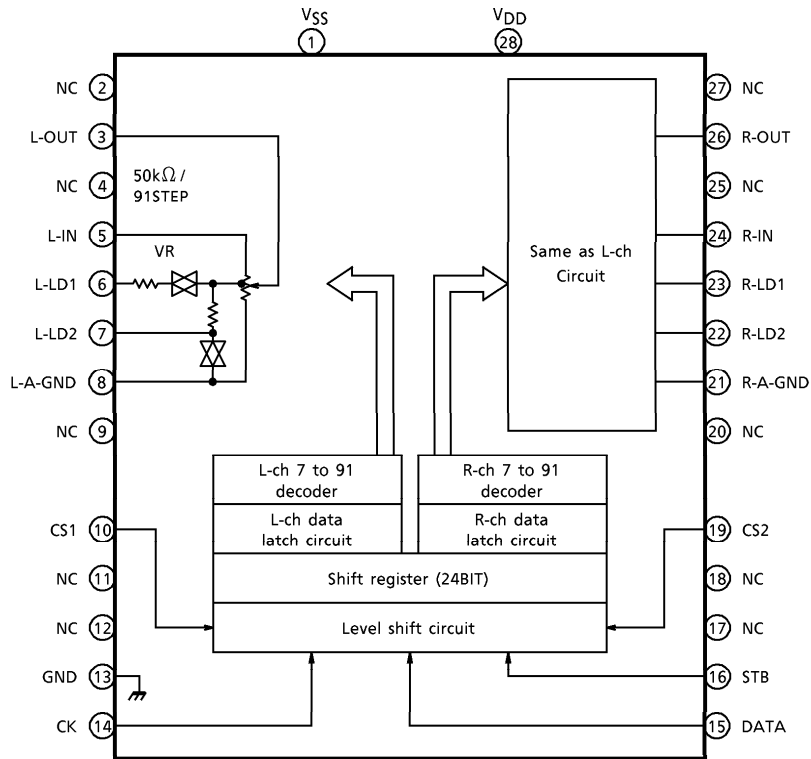

BLOCK DIAGRAM (TC9459F)

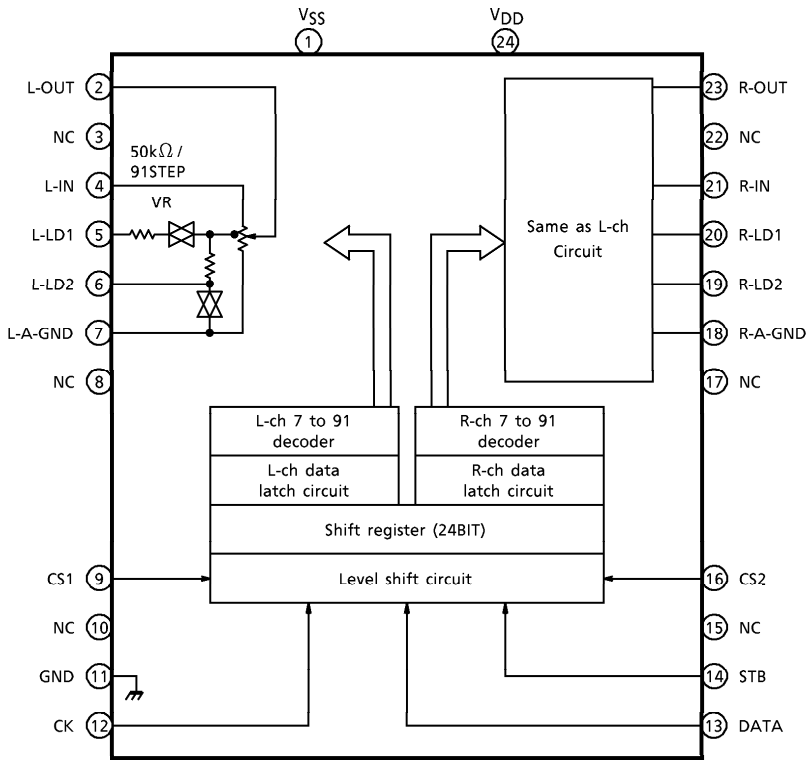

PIN DESCRIPTION

Numeral in () means the pin No. of TC9459F.

PIN No.	SYMBOL	PIN NAME	FUNCTION	REMARK										
1 (1)	V _{SS}	Negative power supply pin	When using dual power supplies <ul style="list-style-type: none"> — V_{DD} = 6.0~17V — GND = 0V — V_{SS} = -6.0~ -17V When using a single power supply <ul style="list-style-type: none"> — V_{DD} = 6.0~18V — GND = V_{SS} = 0V 	—										
28 (24)	V _{DD}	Positive power supply pin												
13 (11)	GND	Digital GND pin												
3 (2)	L-OUT	Volume output pin	• Volume circuit 	—										
26 (23)	R-OUT													
5 (4)	L-IN	Volume input pin												
24 (21)	R-IN													
6 (5)	L-LD1	Loudness tap output pin			<table border="1" style="margin-left: auto; margin-right: auto;"> <thead> <tr> <th></th> <th>LA1</th> <th>LA2</th> </tr> </thead> <tbody> <tr> <td>LOUDNESS "ON"</td> <td>ON</td> <td>OFF</td> </tr> <tr> <td>LOUDNESS "OFF"</td> <td>OFF</td> <td>ON</td> </tr> </tbody> </table>		LA1	LA2	LOUDNESS "ON"	ON	OFF	LOUDNESS "OFF"	OFF	ON
	LA1					LA2								
LOUDNESS "ON"	ON					OFF								
LOUDNESS "OFF"	OFF					ON								
23 (20)	R-LD1													
7 (6)	L-LD2													
22 (19)	R-LD2													
8 (7)	L-A-GND	Analog GND pin												
21 (18)	R-A-GND													
10 (9)	CS1	Chip select input pin	Up to 4 chips on the same bus can be used by switching over chip select code.	—										
19 (16)	CS2													
14 (12)	CK	Clock input pin	Data transfer clock input	Low threshold value input pin										
15 (13)	DATA	Data input pin	Volume setup serial data input											
16 (14)	STB	Strobe input pin	Data write strobe input											
2 (3)	NC	No connection	—	—										
27 (22)														
4														
25														
9 (8)														
20 (17)														
11														
18														
12 (10)														
17 (15)														

DEVICE OPERATION

1. Setting up volume value (amount of attenuation)

Serial data consisting of 24bits is used to set a volume value.

- Data format

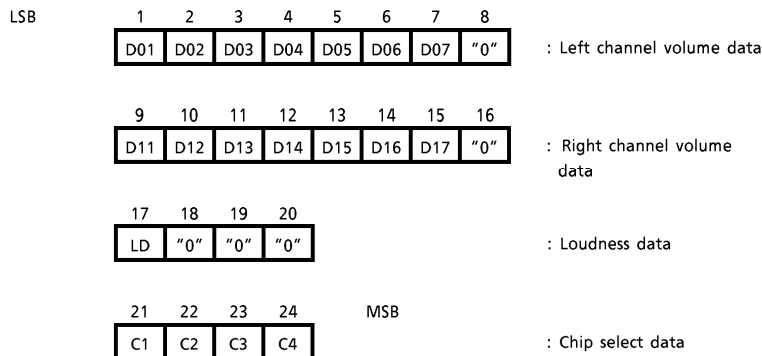
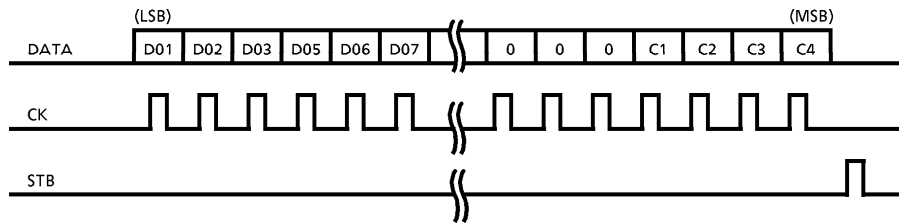

(1) Chip select data

The bits "C1" through "C4" are the chip select code data.

These bits set the code data that corresponds to the CS1 and CS2 inputs.

CS1	CS2	C1	C2	C3	C4
L	L	0	0	0	1
H	L	1	0	0	1
L	H	0	1	0	1
H	H	1	1	0	1

(2) Loudness setting

The bit "LD" is the loudness setup data. Loudness is turned on when LD = 1.

(3) Volume setup data

The bits "D01" through "D07" are the left channel volume setup data, the bits "D11" through "D17" are the right channel volume setup data. For details, see the tables below.

VOLUME VALUE	D01 D11	D02 D12	D03 D13	D04 D14	D05 D15	D06 D16	D07 D17
0dB	0	0	0	0	0	0	0
-1	1	0	0	0	0	0	0
-2	0	1	0	0	0	0	0
-3	1	1	0	0	0	0	0
-4	0	0	1	0	0	0	0
-5	1	0	1	0	0	0	0
-6	0	1	1	0	0	0	0
-7	1	1	1	0	0	0	0
-8	0	0	0	1	0	0	0
-9	1	0	0	1	0	0	0
-10	0	1	0	1	0	0	0
-11	1	1	0	1	0	0	0
-12	0	0	1	1	0	0	0
-13	1	0	1	1	0	0	0
-14	0	1	1	1	0	0	0
-15	1	1	1	1	0	0	0
-16	0	0	0	0	1	0	0
-17	1	0	0	0	1	0	0
-18	0	1	0	0	1	0	0
-19	1	1	0	0	1	0	0
-20	0	0	1	0	1	0	0
-21	1	0	1	0	1	0	0
-22	0	1	1	0	1	0	0
-23	1	1	1	0	1	0	0
-24	0	0	0	1	1	0	0
-25	1	0	0	1	1	0	0
-26	0	1	0	1	1	0	0
-27	1	1	0	1	1	0	0
-28	0	0	1	1	1	0	0
-29	1	0	1	1	1	0	0
-30	0	1	1	1	1	0	0
-31	1	1	1	1	1	0	0
-32	0	0	0	0	0	1	0
-33	1	0	0	0	0	1	0
-34	0	1	0	0	0	1	0
-35	1	1	0	0	0	1	0
-36	0	0	1	0	0	1	0
-37	1	0	1	0	0	1	0
-38	0	1	1	0	0	1	0
-39	1	1	1	0	0	1	0
-40	0	0	0	1	0	1	0
-41	1	0	0	1	0	1	0
-42	0	1	0	1	0	1	0
-43	1	1	0	1	0	1	0
-44	0	0	1	1	0	1	0
-45	1	0	1	1	0	1	0

VOLUME VALUE	D01 D11	D02 D12	D03 D13	D04 D14	D05 D15	D06 D16	D07 D17
-46dB	0	1	1	1	0	1	0
-47	1	1	1	1	0	1	0
-48	0	0	0	0	1	1	0
-49	1	0	0	0	1	1	0
-50	0	1	0	0	1	1	0
-51	1	1	0	0	1	1	0
-52	0	0	1	0	1	1	0
-53	1	0	1	0	1	1	0
-54	0	1	1	0	1	1	0
-55	1	1	1	0	1	1	0
-56	0	0	0	1	1	1	0
-57	1	0	0	1	1	1	0
-58	0	1	0	1	1	1	0
-59	1	1	0	1	1	1	0
-60	0	0	1	1	1	1	0
-61	1	0	1	1	1	1	0
-62	0	1	1	1	1	1	0
-63	1	1	1	1	1	1	0
-64	0	0	0	0	0	0	1
-65	1	0	0	0	0	0	1
-66	0	1	0	0	0	0	1
-67	1	1	0	0	0	0	1
-68	0	0	1	0	0	0	1
-69	1	0	1	0	0	0	1
-70	0	1	1	0	0	0	1
-71	1	1	1	0	0	0	1
-72	0	0	0	1	0	0	1
-73	1	0	0	1	0	0	1
-74	0	1	0	1	0	0	1
-75	1	1	0	1	0	0	1
-76	0	0	1	1	0	0	1
-77	1	0	1	1	0	0	1
-78	0	1	1	1	0	0	1
-79	1	1	1	1	0	0	1
-80	0	0	0	0	1	0	1
-81	1	0	0	0	1	0	1
-82	0	1	0	0	1	0	1
-83	1	1	0	0	1	0	1
-84	0	0	1	0	1	0	1
-85	1	0	1	0	1	0	1
-86	0	1	1	0	1	0	1
-87	1	1	1	0	1	0	1
-88	0	0	0	1	1	0	1
-89	1	0	0	1	1	0	1
-∞	0	1	0	1	1	0	1

2. Serial data timing

Make sure that CK, DATA and STB are input to the device at the timings shown below.

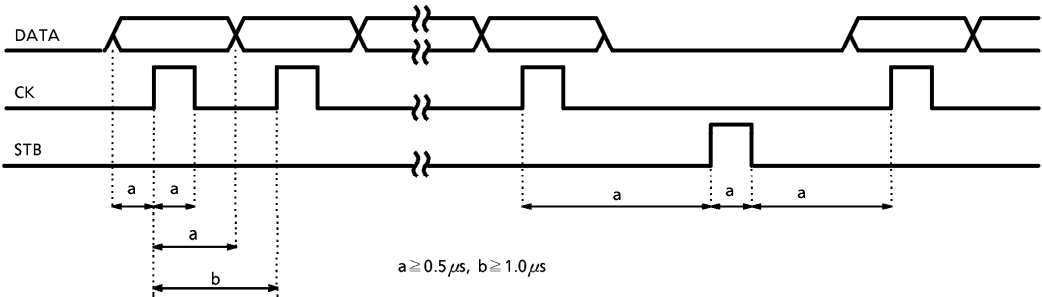

3. Operating with a single or dual power supplies

The TC9459N, TC9459F can operate with either a single power supply or dual power supplies.

- Operation with single power supply

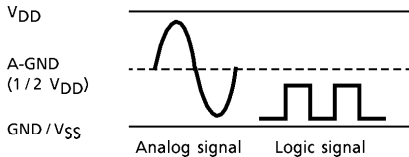

- Operation with dual power supplies

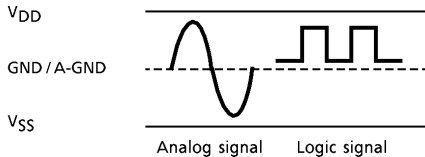

MAXIMUM RATINGS (Ta = 25°C)

CHARACTERISTIC	SYMBOL	RATING	UNIT
Supply Voltage (1)	V _{DD} -V _{SS}	-0.3~36	V
Supply Voltage (2)	V _{DD} -GND	-0.3~20	V
GND Block Input Voltage	V _{IN} (1)	-0.3~V _{DD} +0.3	V
V _{SS} Block Input Voltage	V _{IN} (2)	V _{SS} -0.3~V _{DD} +0.3	V
Power Dissipation	P _D	300	mW
Operating Temperature	T _{opr}	-40~85	°C
Storage Temperature	T _{stg}	-65~150	°C

ELECTRICAL CHARACTERISTICS

(Referenced to V_{DD} = 15V, V_{SS} = -15V, GND = 0V at Ta = 25°C unless otherwise noted)

CHARACTERISTIC	SYMBOL	TEST CIRCUIT	TEST CONDITION	MIN.	TYP.	MAX.	UNIT
Operating Supply Voltage (1)	V _{DD} -V _{SS}	—	Operating with dual power supplies	12	~	34	V
Operating Supply Voltage (2)	V _{DD} -GND	—	Operating with single power supply	6.0	~	18	V
Operating Supply Current	I _{DD}	1	Non-loaded, no input	—	0.5	2.0	mA
Input Voltage	"H" Level	V _{IH} (1)	CK, DATA, STB pins V _{DD} = 6.0~18V	4.0	~	V _{DD}	V
	"L" Level	V _{IL} (1)		GND	~	1.0	
Input Voltage	"H" Level	V _{IH} (2)	CS1 and CS2 pins	V _{DD} × 0.7	~	V _{DD}	V
	"L" Level	V _{IL} (2)		GND	~	V _{DD} × 0.3	
Input Current	"H" Level	I _{IH}	CK, DATA, STB, CS1, CS2 pins V _{IH} = 15V V _{IL} = 0V	-1.0	~	1.0	μA
	"L" Level	I _{IL}		-1.0	~	1.0	
Operating Frequency	f _{op}	—	CK, DATA, STB pins	0	~	1.0	MHz
Min. Operating Clock Width	T _{ck}	—		0.5	—	—	μs
Volume Resistance	R _{VR}	—	When loudness OFF	20.5	29.3	38.2	kΩ
Step Deviation	ΔV _R	—	Deviation between volume steps	-1.2	~	1.2	dB
Analog Switch ON-Resistance	R _{ON} (1)	—	Analog switch LA2 only	—	350	—	Ω
	R _{ON} (2)	—	All analog switch except for LA2	—	750	1500	
Analog Switch Leakage Current	I _{OFF}	—	Internal analog switch	-0.1	~	0.1	μA
Total Harmonic Distortion	THD	1	f _{IN} = 1kHz V _{IN} = 1V _{rms} R _G = 600Ω, R _L = 100kΩ BW = 20Hz~20kHz	—	0.005	—	%
Maximum Attenuation	ATT _{MAX}			—	100	—	dB
Output Noise Voltage	V _N			—	1.0	—	μV _{rms}
Crosstalk	C-T			—	100	—	dB

TEST CIRCUIT 1 (I_{DD} /THD/ATT_{MAX}/V_N/CT)

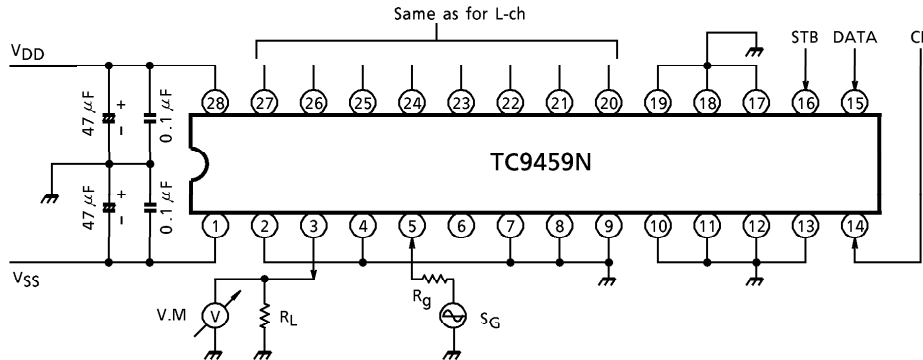

EXAMPLE OF APPLICATION CIRCUIT (TC9459N)

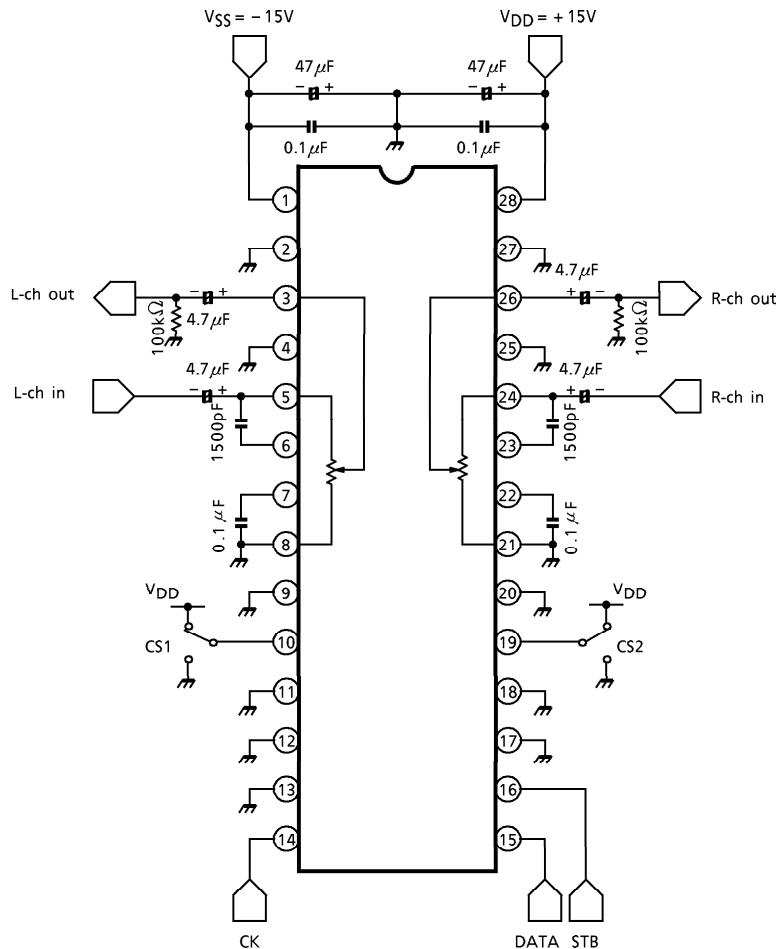

(Note) Since a high-frequency digital signal is input to the CK, DATA and STB pins, corrective measures must be taken to prevent it from getting mixed in the analog circuit to generate noise by, for example, guarding the above signal lines with ground patterns or using shielding wire for these lines.

PACKAGE DIMENSIONS
SDIP28-P-400-1.78

Unit : mm

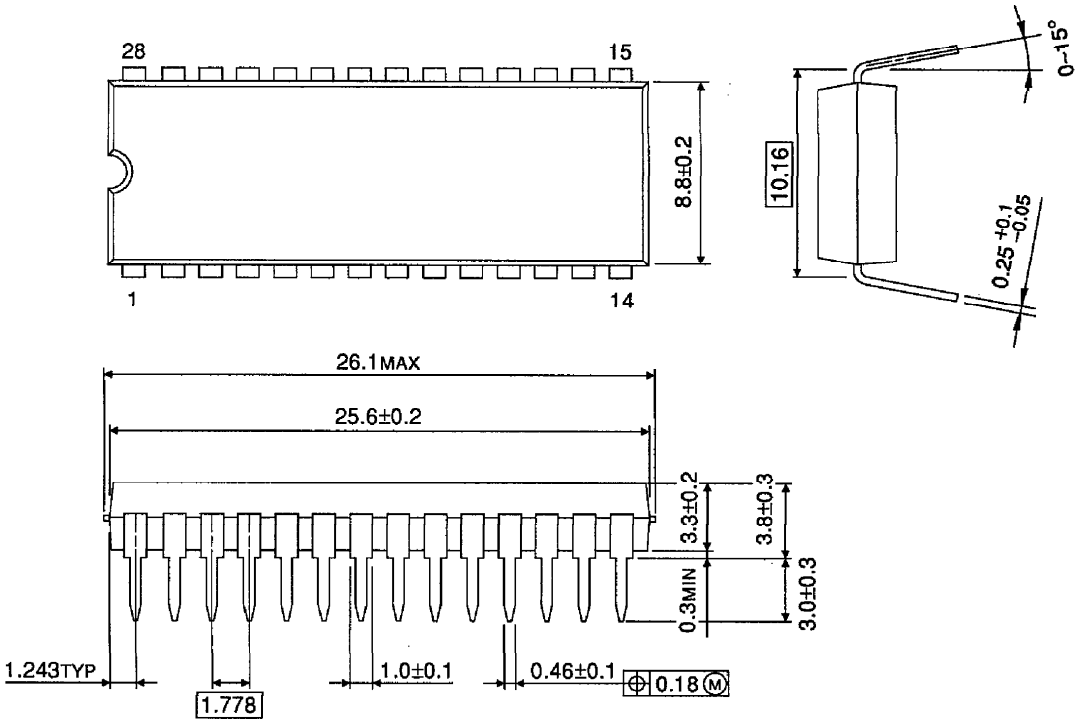

Weight : 2.2g (Typ.)

PACKAGE DIMENSIONS
SOP24-P-450-1.27A

Unit : mm

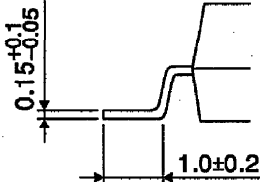
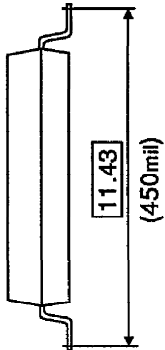
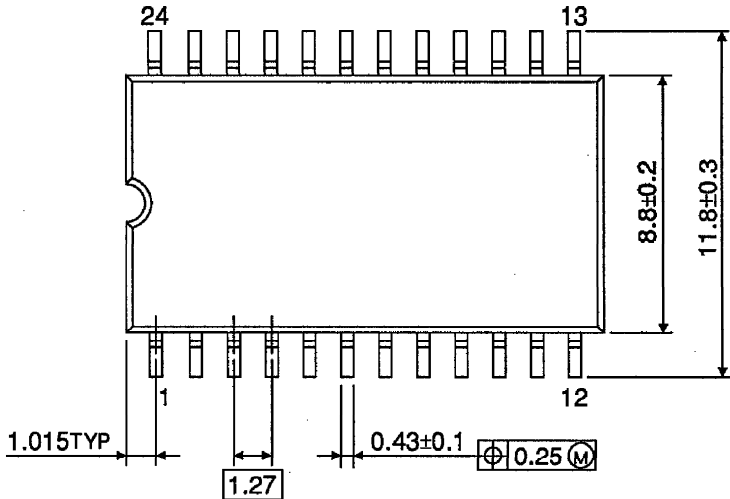

Weight : 0.44g (Typ.)

RESTRICTIONS ON PRODUCT USE

000707EBA

- TOSHIBA is continually working to improve the quality and reliability of its products. Nevertheless, semiconductor devices in general can malfunction or fail due to their inherent electrical sensitivity and vulnerability to physical stress. It is the responsibility of the buyer, when utilizing TOSHIBA products, to comply with the standards of safety in making a safe design for the entire system, and to avoid situations in which a malfunction or failure of such TOSHIBA products could cause loss of human life, bodily injury or damage to property. In developing your designs, please ensure that TOSHIBA products are used within specified operating ranges as set forth in the most recent TOSHIBA products specifications. Also, please keep in mind the precautions and conditions set forth in the "Handling Guide for Semiconductor Devices," or "TOSHIBA Semiconductor Reliability Handbook" etc..
- The TOSHIBA products listed in this document are intended for usage in general electronics applications (computer, personal equipment, office equipment, measuring equipment, industrial robotics, domestic appliances, etc.). These TOSHIBA products are neither intended nor warranted for usage in equipment that requires extraordinarily high quality and/or reliability or a malfunction or failure of which may cause loss of human life or bodily injury ("Unintended Usage"). Unintended Usage include atomic energy control instruments, airplane or spaceship instruments, transportation instruments, traffic signal instruments, combustion control instruments, medical instruments, all types of safety devices, etc.. Unintended Usage of TOSHIBA products listed in this document shall be made at the customer's own risk.
- The products described in this document are subject to the foreign exchange and foreign trade laws.
- The information contained herein is presented only as a guide for the applications of our products. No responsibility is assumed by TOSHIBA CORPORATION for any infringements of intellectual property or other rights of the third parties which may result from its use. No license is granted by implication or otherwise under any intellectual property or other rights of TOSHIBA CORPORATION or others.
- The information contained herein is subject to change without notice.