

TOSHIBA

**32bit TX System RISC
TX19A Family**

TMP19A43FD/FZXBG

Rev2.0 2007.Apr.9

32-bit RISC Microprocessor - TX19 Family

TMP19A43FZXBG, FDXBG

1. Overview and Features

The TX19 family is a high-performance 32-bit RISC processor series that TOSHIBA originally developed by integrating the MIPS16™ASE (Application Specific Extension), which is an extended instruction set of high code efficiency.

TMP19A43 is a 32-bit RISC microprocessor with a TX19A processor core and various peripheral functions integrated into one package. It can operate at low voltage with low power consumption.

Features of TMP19A43 are as follows:

RESTRICTIONS ON PRODUCT USE

070122EBP

- The information contained herein is subject to change without notice. 021023_D
- TOSHIBA is continually working to improve the quality and reliability of its products. Nevertheless, semiconductor devices in general can malfunction or fail due to their inherent electrical sensitivity and vulnerability to physical stress. It is the responsibility of the buyer, when utilizing TOSHIBA products, to comply with the standards of safety in making a safe design for the entire system, and to avoid situations in which a malfunction or failure of such TOSHIBA products could cause loss of human life, bodily injury or damage to property.
In developing your designs, please ensure that TOSHIBA products are used within specified operating ranges as set forth in the most recent TOSHIBA products specifications. Also, please keep in mind the precautions and conditions set forth in the "Handling Guide for Semiconductor Devices," or "TOSHIBA Semiconductor Reliability Handbook" etc. 021023_A
- The TOSHIBA products listed in this document are intended for usage in general electronics applications (computer, personal equipment, office equipment, measuring equipment, industrial robotics, domestic appliances, etc.). These TOSHIBA products are neither intended nor warranted for usage in equipment that requires extraordinarily high quality and/or reliability or a malfunction or failure of which may cause loss of human life or bodily injury ("Unintended Usage"). Unintended Usage include atomic energy control instruments, airplane or spaceship instruments, transportation instruments, traffic signal instruments, combustion control instruments, medical instruments, all types of safety devices, etc. Unintended Usage of TOSHIBA products listed in this document shall be made at the customer's own risk. 021023_B
- The products described in this document shall not be used or embedded to any downstream products of which manufacture, use and/or sale are prohibited under any applicable laws and regulations. 060106_Q
- The information contained herein is presented only as a guide for the applications of our products. No responsibility is assumed by TOSHIBA for any infringements of patents or other rights of the third parties which may result from its use. No license is granted by implication or otherwise under any patents or other rights of TOSHIBA or the third parties. 070122_C
- The products described in this document are subject to foreign exchange and foreign trade control laws. 060925_E
- For a discussion of how the reliability of microcontrollers can be predicted, please refer to Section 1.3 of the chapter entitled Quality and Reliability Assurance/Handling Precautions. 030619_S

- (1) TX19A processor core
 - 1) Improved code efficiency and operating performance have been realized through the use of two ISA (Instruction Set Architecture) modes - 16- and 32-bit ISA modes.
 - The 16-bit ISA mode instructions are compatible with the MIPS16™ ASE instructions of superior code efficiency at the object level.
 - The 32-bit ISA mode instructions are compatible with the TX39 instructions of superior operating performance at the object level.
 - 2) Both high performance and low power dissipation have been achieved.
 - High performance
 - Almost all instructions can be executed with one clock.
 - High performance is possible via a three-operand operation instruction.
 - 5-stage pipeline
 - Built-in high-speed memory
 - DSP function: A 32-bit multiplication and accumulation operation can be executed with one clock.
 - Low power dissipation
 - Optimized design using a low power dissipation library
 - Standby function that stops the operation of the processor core
 - 3) High-speed interrupt response suitable for real-time control
 - Independency of the entry address
 - Automatic generation of factor-specific vector addresses
 - Automatic update of interrupt mask levels

(2) Internal program memory and data memory

Product name	Built-in ROM	Built-in RAM
TMP19A43CZXBG	384Kbyte	20Kbyte
TMP19A43CDXBG *	512Kbyte	24Kbyte
TMP19A43FZXBG *	384Kbyte (Flash)	20Kbyte
TMP19A43FDXBG	512Kbyte (Flash)	24Kbyte

The product indicated by an asterisk * is under development.

- ROM correction function: 1 word × 8 blocks, 8 words × 4 blocks
- (3) External memory expansion
 - Expandable to 16 megabytes (for both programs and data)
 - External data bus:
 - Separate bus/multiplexed bus : Coexistence of 8- and 16-bit widths is possible.
 - Chip select/wait controller : 4 channels
 - (4) DMA controller : 8 channels (2 interrupt factors)
 - Activated by an interrupt or software
 - Data to be transferred to internal memory, internal I/O, external memory, and external I/O
 - (5) 16-bit timer : 16 channels
 - 16-bit interval timer mode
 - 16-bit event counter mode
 - 16-bit PPG output (every 4 channels, synchronous outputs are possible)
 - Input capture function
 - 2-phase pulse input counter function (4 channels assigned to perform this function): Multiplication-by-4 mode

- (6) 32-bit timer
 - 32-bit input capture register : 4 channels
 - 32-bit compare register : 8 channels
 - 32-bit time base timer : 1 channel
- (7) Clock timer : 1 channel
- (8) General-purpose serial interface : 3 channels
 - Selectable between the UART mode and the synchronization mode
- (9) High-speed serial interface : 3 channels
 - Selectable between the UART mode and the high-speed synchronization mode (maximum speed: 10 Mbps in the high-speed synchronization mode @40MHz)
- (10) Serial bus interface : 1 channel
 - Selectable between the I²C bus mode and the clock synchronization mode
- (11) 10-bit A/D converter (with S/H) : 16 channels
 - Start by an external trigger, and the internal timer activated by a trigger
 - Fixed channel/scan mode
 - Single/repeat mode
 - High-priority conversion mode
 - Timer monitor function
 - Conversion time 1.15 μsec(@ 40MHz)
- (12) 8-bit D/A converter : 2 channels
- (13) Watchdog timer : 1 channel
- (14) Interrupt function
 - CPU: 2 factorssoftware interrupt instruction
 - Internal: 46 factors.....The order of precedence can be set over 7 levels (except the watchdog timer interrupt).
 - External: 48 factorsThe order of precedence can be set over 7 levels.
Because 32 factors are associated with KWUP, the number of interrupt factors is one.
- (15) Input and output ports 143 terminals
- (16) Standby function
 - Three standby modes (IDLE, SLEEP, STOP)
- (17) Clock generator
 - Built-in PLL (multiplication by 4)
 - Clock gear function: The high-speed clock can be divided into 3/4, 1/2, 1/4 or 1/8.
 - Sub-clock: SLOW and SLEEP modes (32.768 kHz)
- (18) Endian: Bi-endian (big-endian/little-endian)
- (19) Maximum operating frequency
 - 40 MHz (PLL multiplication)
- (20) Operating voltage range
 - Core: 1.35 V to 1.65 V
 - I/O and ADC: 2.7 V to 3.6 V
 - DAC: 2.3 V to 2.7 V
- (21) Package
 - P-FBGA193 (12 mm × 12 mm, 0.65 mm pitch)

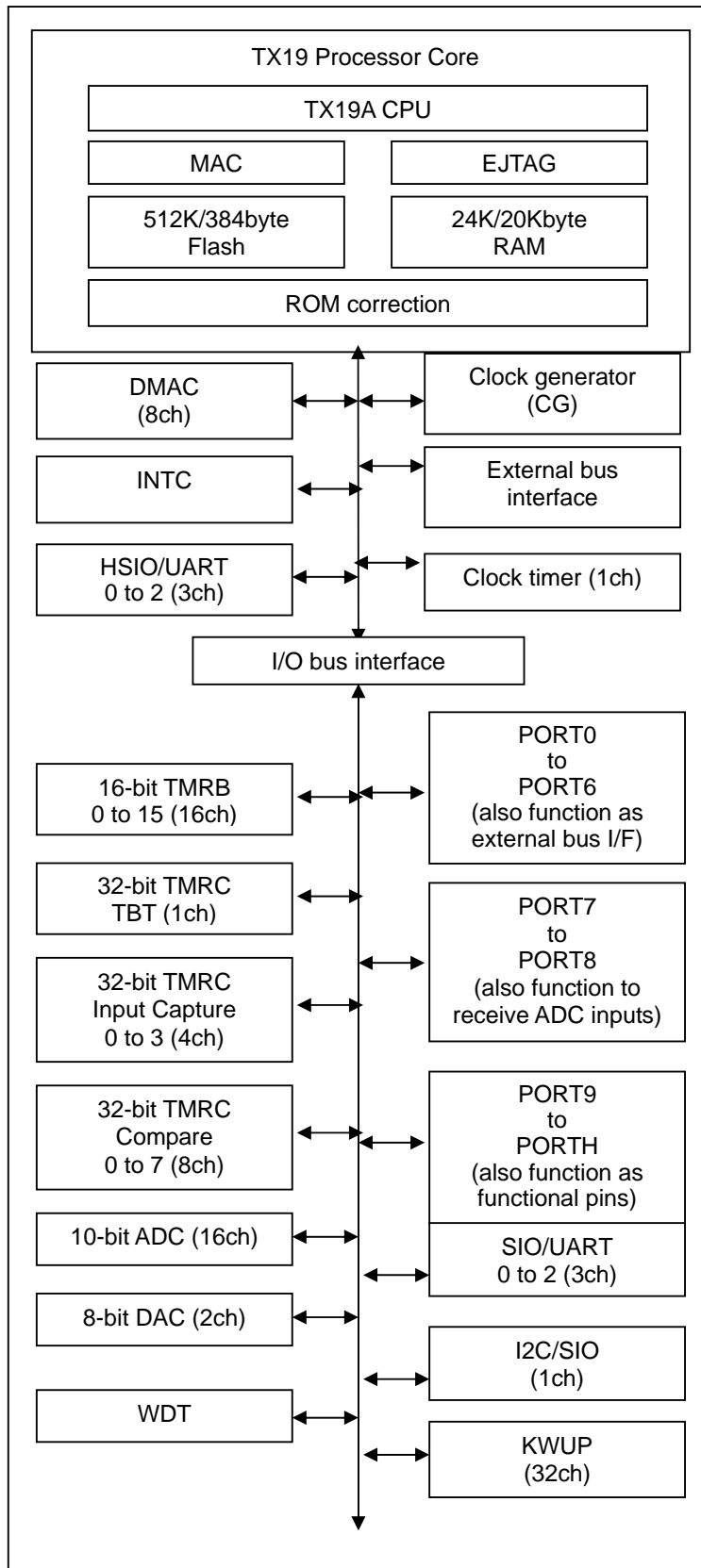

Fig. 1-1 TMP19A43 Block Diagram

2. Pin Layout and Pin Functions

This section shows the pin layout of TMP19A43 and describes the names and functions of input and output pins.

2.1 Pin Layout (Top view)

Fig. 2-1 Pin Layout Diagram (P-FBGA193) shows the pin layout of TMP19A43.

A1	A2	A3	A4	A5	A6	A7	A8	A9	A10	A11	A12	A13	A14	A15	A16	A17
B1	B2	B3	B4	B5	B6	B7	B8	B9	B10	B11	B12	B13	B14	B15	B16	B17
C1	C2														C16	C17
D1	D2	D4	D5	D6	D7	D8	D9	D10	D11	D12	D13	D14				
E1	E2	E4	E5	E6	E7	E8	E9	E10	E11	E12	E13	E14				
F1	F2	F4	F5	F6							F13	F14	F16	F17		
G1	G2	G4	G5							G13	G14	G16	G17			
H1	H2	H4	H5							H13	H14	H16	H17			
J1	J2	J4	J5							J13	J14	J16	J17			
K1	K2	K4	K5							K13	K14	K16	K17			
L1	L2	L4	L5							L13	L14	L16	L17			
M1	M2	M4	M5							M13	M14	M16	M17			
N1	N2	N4	N5	N6	N7	N8	N9	N10	N11	N12	N13	N14				
P1	P2	P4	P5	P6	P7	P8	P9	P10	P11	P12	P13	P14				
R1	R2														R16	R17
T1	T2	T3	T4	T5	T6	T7	T8	T9	T10	T11	T12	T13	T14	T15	T16	T17
U1	U2	U3	U4	U5	U6	U7	U8	U9	U10	U11	U12	U13	U14	U15	U16	U17

Fig. 2-1 Pin Layout Diagram (P-FBGA193)

2.2 Pin Numbers and Names

Table 2-1 shows the pin numbers and names of TMP19A43.

Table 2-1 Pin numbers and names

Pin No.	Pin Name	Pin No.	Pin Name	Pin No.	Pin Name	Pin No.	Pin Name	Pin No.	Pin Name
A1	DVSS	D2	PF3/KEY19/DACK4	G2	P95/SCLK2/CTS2	M1	PB5/HTXD1	R2	P33/WAIT/RDY
A2	P81/AN9/KEY05	D4	P71/AN1	G4	P94/RXD2	M2	PB4/HSCLK0/HCTS0	R16	P45/BUSMD
A3	P83/AN11/KEY07	D5	P73/AN3	G5	P93/TXD2	M4	PB3/HRXD0	R17	P46/ENDIAN
A4	P85/AN13/INT7	D6	P74/AN4/KEY00	G13	PH1/TPC1/TPD1	M5	TEST4	T1	P37/ALE/TC3IN
A5	P87/AN15/INT9	D7	P76/AN6/KEY02	G14	PH7/TPC7/TPD7	M13	FVCC3	T2	P34/BUSRQ/TBEOUT
A6	DA0	D8	PD5/TBDOUT	G16	PCST4	M14	PG3/TPD3	T3	P30/RD
A7	CVREF0	D9	PD3/TBBOUT	G17	DCLK	M16	PG4/TPD4	T4	P02/D2/AD2
A8	DA1	D10	PD0/HTXD2	H1	PC1/TCOUT0	M17	PG5/TPD2	T5	P06/D6/AD6
A9	CVREF1	D11	PE0/KEY8	H2	PC0/TBTIN/KEY30	N1	PB7/HSCLK1/HCTS1	T6	P12/D10/AD10/A10
A10	PD2/HSCLK2/HCTS2	D12	PE3/KEY11	H4	P97/TBAOUT	N2	PB6/HRXD1	T7	P16/D14/AD14/A14
A11	PE2/KEY10	D13	PA2/INT2/TB7IN0	H5	DVCC3	N4	P00/D0/AD0	T8	P21/A17/A1/TB0IN1
A12	PE5/KEY13	D14	PH4/TPC4/TPD4	H13	PH2/TPC2/TPD2	N5	P04/D4/AD4	T9	P24/A20/A4/TB4IN0
A13	PE7/KEY15	D16	PA3/INT3/TB7IN1	H14	TRST	N6	P10/D8/AD8/A8	T10	P26/A22/A6/TB5IN0
A14	X1	D17	XT1	H16	TMS	N7	P14/D12/AD12/A12	T11	P52/A2/INTE
A15	X2	E1	PF6/KEY22/TCOUT6	H17	EJE	N8	FVCC3	T12	P56/A6/TB2OUT/KEY28
A16	CVCCH	E2	PF5/KEY21/TCOUT5	J1	PC4/TCOUT3	N9	DVSS	T13	P62/A10/SCLK0/CTS0
A17	CVSS	E4	P70/AN0	J2	PC3/TCOUT2	N10	DVCC15	T14	P66/A14/TB4OUT
B1	PF0/KEY16/DREQ0	E5	P72/AN2	J4	PC2/TCOUT1	N11	P50/A0/INTC	T15	P40/CS0/KEY24
B2	P80/AN8/KEY04	E6	VREFH	J5	DVCC15	N12	P54/A4/TB0OUT	T16	P42/CS2/KEY26
B3	P82/AN10/KEY06	E7	AVSS	J13	PH3/TPC3/TPD3	N13	P60/A8/TXD0	T17	P44/SCOUT
B4	P84/AN12/INT6	E8	DAVCC	J14	DINT	N14	P64/A12/RXD1/INTB	U1	TEST2
B5	P86/AN14/INT8	E9	DAVREF	J16	TDO	N16	PG6/TPD6	U2	P35/BUSAK/TC1IN
B6	P75/AN5/KEY01	E10	DAGND	J17	DVSS	N17	PG7/TPD7	U3	P31/WR
B7	P77/AN7/KEY03	E11	DVCC3	K1	PC7/SCK	P1	BOOT	U4	P03/D3/AD3
B8	PD6/KEY31/AFTRG	E12	PA0/INT0/TB6IN0	K2	PC6/SI/SCL	P2	P32/HWR/TC0IN	U5	P07/D7/AD7
B9	PD4/TBCOUT	E13	PA1/INT1/TB6IN1	K4	PC5/SO/SDA	P4	P01/D1/AD1	U6	P13/D11/AD11/A11
B10	PD1/HRXD2	E14	PH5/TPC5/TPD5	K5	DVSS	P5	P05/D5/AD5	U7	P17/D15/AD15/A15
B11	PE1/KEY09	E16	PCST0	K13	DVCC15	P6	P11/D9/AD9/A9	U8	P22/A18/A2/TB1IN0
B12	PE4/KEY12	E17	PCST1	K14	TOVR/TSTA	P7	P15/D13/AD13/A13	U9	P25/A21/A5/TB4IN1
B13	PE6/KEY14	F1	PF7/KEY23/TCOUT7	K16	TDI	P8	P20/A16/A0/TB0IN0	U10	P27/A23/A7/TB5IN1
B14	PA5/INT5/TB8IN1	F2	P92/TB8OUT	K17	TCK	P9	P23/A19/A3/TB1IN1	U11	P53/A3/INTF
B15	PA6/TB2IN0	F4	P91/TB7OUT	L1	PB2/HTXD0	P10	TEST0	U12	P57/A7/TB3OUT/KEY29
B16	PA7/TB2IN1	F5	P90/TB6OUT	L2	PB1/TB3IN1	P11	P51/A1/INTD	U13	P63/A11/TXD1
B17	CVCC	F6	AVCC3	L4	PB0/TB3IN0	P12	P55/A5/TB1OUT	U14	P67/A15/TB5OUT
C1	PF2/KEY18/DREQ4	F13	PH0/TPC0/TPD0	L5	TEST1	P13	P61/A9/RXD0/INTA	U15	P41/CS1/KEY25
C2	PF1/KEY17/DACK0	F14	PH6/TPC6/TPD6	L13	DVSS	P14	P65/A13/SCLK1/CTS1	U16	P43/CS3/KEY27
C16	PA4/INT4/TB8IN0	F16	PCST2	L14	PG0/TPD0	P16	P47/TBFOUT	U17	TEST3
C17	XT2	F17	PCST3	L16	PG1/TPD1	P17	RESET		
D1	PF4/KEY20/TCOUT4	G1	P96/TB9OUT	L17	PG2/TPD2	R1	P36/RW/TC2IN		

2.3 Pin Names and Functions

Table 2-2 through Table 2-7 show the names and functions of input and output pins.

Table 2-2 Pin Names and Functions (1 of 6)

Pin name	Number of pins	Input or output	Function
P00-P07 D0-D7 AD0-D7	8	Input/output Input/output Input/output	Port 0: Input/output port (with pull-up) that allows input/output to be set in units of bits Data (lower): Data bus 0 to 7 (separate bus mode) Address data (lower): Address data bus 0 to 7 (multiplexed bus mode)
P10-P17 D8-D15 AD8-AD15 A8-A15	8	Input/output Input/output Input/output Output	Port 1: Input/output port (with pull-up) that allows input/output to be set in units of bits Data (upper): Data bus 8 to 15 (separate bus mode) Address data (upper): Address data bus 8 to 15 (multiplexed bus mode) Address: Address bus 8 to 15 (multiplexed bus mode)
P20-P27 A16-A23 A0-A7 TB0IN0,TB0IN1 TB1IN0,TB1IN1 TB4IN0,TB4IN1 TB5IN0,TB5IN1	8	Input/output Output Output Input Input Input Input	Port 2: Input/output port (with pull-up) that allows input/output to be set in units of bits Address: Address bus 15 to 23 (separate bus mode) Address: Address bus 0 to 7 (multiplexed bus mode) 16-bit timer 0 input 0,1: For inputting the count/capture trigger of a 16-bit timer 0 16-bit timer 1 input 0,1: For inputting the count/capture trigger of a 16-bit timer 1 16-bit timer 4 input 0,1: For inputting the count/capture trigger of a 16-bit timer 4 16-bit timer 5 input 0,1: For inputting the count/capture trigger of a 16-bit timer 5
P30 \overline{RD}	1	Output Output	Port 30: Port used exclusively for output Read: Strobe signal for reading external memory
P31 \overline{WR}	1	Output Output	Port 31: Port used exclusively for output Write: Strobe signal for writing data of D0 to D7 pins
P32 \overline{HWR} TC0IN	1	Input/output Output Input	Port 32: Input/output port (with pull-up) Write upper-pin data: Strobe signal for writing data of D8 to D15 pins For inputting the capture trigger for 32-bit timer
P33 \overline{WAIT} RDY	1	Input/output Input Input	Port 33: Input/output port (with pull-up) Wait: Pin for requesting CPU to put a bus in a wait state Ready: Pin for notifying CPU that a bus is ready
P34 \overline{BUSRQ} TBEOU	1	Input/output Input Output	Port 34: Input/output port (with pull-up) Bus request: Signal requesting CPU to allow an external master to take the bus control authority 16-bit timer E output: Pin for outputting 16-bit timer E
P35 \overline{BUSAK} TC1IN	1	Input/output Output Input	Port 35: Input/output port (with pull-up) Bus acknowledge: Signal notifying that CPU has released the bus control authority in response to \overline{BUSRQ} For inputting the capture trigger for 32-bit timer
P36 R/ \overline{W} TC2IN	1	Input/output Output Input	Port 36: Input/output port (with pull-up) Read/write: "1" shows a read cycle or a dummy cycle. "0" shows a write cycle. For inputting the capture trigger for 32-bit timer
P37 ALE TC3IN	1	Input/output Output Input	Port 37: Input/output port (with pull-up) Address latch enable (address latch is enabled only if access to external memory is taking place) For inputting the capture trigger for 32-bit timer
P40 $\overline{CS0}$ KEY24	1	Input/output Output Input	Port 40: Input/output port (with pull-up) Chip select 0: "0" is output if the address is in a designated address area. KEY on wake up input 24: (Dynamic pull up is selectable) Input with Schmitt trigger with Noise filter
P41 $\overline{CS1}$ KEY25	1	Input/output Output Input	Port 41: Input/output port (with pull-up) Chip select 1: "0" is output if the address is in a designated address area. KEY on wake up input 25: (Dynamic pull up is selectable) Input with Schmitt trigger with Noise filter
P42 $\overline{CS2}$ KEY26	1	Input/output Output Input	Port 42: Input/output port (with pull-up) Chip select 2: "0" is output if the address is in a designated address area. KEY on wake up input 26: (Dynamic pull up is selectable) Input with Schmitt trigger with Noise filter

Table 2-3 Pin Names and Functions (2 of 6)

Pin name	Number of pins	Input or output	Function
P43 $\overline{\text{CS3}}$ KEY27	1	Input/output Output Input	Port 43: Input/output port (with pull-up) Chip select 3: "0" is output if the address is in a designated address area. KEY on wake up input 27: (Dynamic pull up is selectable) Input with Schmitt trigger with Noise filter
P44 SCOUT	1	Input/output Output	Port 44: Input/output port (with pull-up) System clock output: Selectable between high- and low-speed clock outputs, as in the case of CPU
P45 BUSMD	1	Input/output Input	Port 45: Input/output port (with pull-up) Pin for setting an external bus mode: This pin functions as a multiplexed bus by sampling the "H (DVCC3) level" at the rise of a reset signal. It also functions as a separate bus by sampling "L" at the rise of a reset signal. When performing a reset operation, pull it up or down according to a bus mode to be used. Input with Schmitt trigger. (After a reset operation is performed, it can be used as a port.)
P46 ENDIAN	1	Input/output Input	Port 46: Input/output port (with pull-up) This pin is used to set a mode. It performs a big-endian operation by sampling the "H (DVCC3) level" at the rise of a reset signal, and performs a little-endian operation by sampling "L" at the rise of a reset signal. When performing a reset operation, pull it up or down according to the type of endian to be used. (After a reset operation is performed, it can be used as a port.) Input with Schmitt trigger
P47 TBFOUT	1	Input/output Output	Port 47: Input/output port (with pull-up) 16-bit timer F output: Pin for outputting a 16-bit timer F
P50-P53 A0-A3 INTC-INTF	4	Input/output Output Input	Port 5: Input/output port (with pull-up) that allows input/output to be set in units of bits Address: Address buses 0 to 3 (separate bus mode) Interrupt request pins C to F: Selectable between "H" level, "L" level, rising edge, and falling edge Input pin with Schmitt trigger with Noise filter
P54,P55 A4,A5 TB0OUT TB1OUT	2	Input/output Output Output Output	Port 5: Input/output port (with pull-up) that allows input/output to be set in units of bits Address: Address buses 4 and 5 (separate bus mode) 16-bit timer 0 output: Pin for outputting a 16-bit timer 0 16-bit timer 1 output: Pin for outputting a 16-bit timer 1
P56,P57 A6,A7 TB2OUT TB3OUT KEY28,KEY29	2	Input/output Output Output Output Input	Port 5: Input/output port (with pull-up) that allows input/output to be set in units of bits Address: Address buses 6 and 7 (separate bus mode) 16-bit timer 2 output: Pin for outputting a 16-bit timer 2 16-bit timer 3 output: Pin for outputting a 16-bit timer 3 KEY on wake up input 28 and 29: (Dynamic pull up is selectable) Input pin with Schmitt trigger with Noise filter
P60 A8 TXD0	1	Input/output Output Output	Port 60: Input/output port (with pull-up) Address: Address bus 8 (separate bus mode) Sending serial data 0: Open drain output pin depending on the program used
P61 A9 RXD0 INTA	1	Input/output Output Input Input	Port 61: Input/output port (with pull-up) Address: Address bus 9 (separate bus mode) Receiving serial data 0 Interrupt request pin A: Selectable between "H" level, "L" level, rising edge, falling edge, and both rising and falling edges. Input pin with Schmitt trigger with Noise filter
P62 A10 $\overline{\text{SCLK0}}$ CTS0	1	Input/output Output Input/output Input	Port 62: Input/output port (with pull-up) Address: Address bus 10 (separate bus mode) Serial clock input/output 0 Handshake input pin Open drain output pin depending on the program used
P63 A11 TXD1	1	Input/output Output Output	Port 63: Input/output port (with pull-up) Address: Address bus 11 (separate bus mode) Sending serial data 1: Open drain output pin depending on the program used
P64 A12 RXD1 INTB	1	Input/output Output Input Input	Port 64: Input/output port (with pull-up) Address: Address bus 12 (separate bus mode) Receiving serial data 1 Interrupt request pin B: Selectable between "H" level, "L" level, rising edge, falling edge, and both rising and falling edges. Input pin with Schmitt trigger with Noise filter

Table 2-4 Pin Names and Functions (3 of 6)

Pin name	Number of pins	Input or output	Function
P65 A13 SCLK1 CTS1	1	Input/output Output Input/output Input	Port 65: Input/output port (with pull-up) Address: Address bus 13 (separate bus mode) Serial clock input/output 1 Handshake input pin. Open drain output pin depending on the program used
P66,P67 A14,A15 TB4OUT TB5OUT	2	Input/output Output Output Output	Port 6: Input/output port (with pull-up) that allows input/output to be set in units of bits Address: Address buses 14 and 15 (separate bus mode) 16-bit timer 4 output: Pin for outputting a 16-bit timer 4 16-bit timer 5 output: Pin for outputting a 16-bit timer 5
P70-P73 AIN0-AIN3	4	Input Input	Port 7: Port used exclusively for input (with pull-up) Analog input: Input from A/D converter
P74-P77 AIN4-AIN7 KEY00-KEY03	4	Input Input Input	Port 7: Port used exclusively for input (with pull-up) Analog input: Input from A/D converter KEY on wake up input 00 to 03: (Dynamic pull up is selectable) Input pin with Schmitt trigger with Noise filter
P80-P83 AIN8-AIN11 KEY04-KEY07	4	Input Input Input	Port 8: Port used exclusively for input (with pull-up) Analog input: Input from A/D converter KEY on wake up input 04 to 07: (Dynamic pull up is selectable) Input pin with Schmitt trigger with Noise filter
P84-P87 AIN12-AIN15 INT6-9	4	Input Input	Port 8: Port used exclusively for input (with pull-up) Analog input: Input from A/D converter Interrupt request pins 6 to 9: Selectable between "H" level, "L" level, rising edge, falling edge, and both rising and falling edges. Input pin with Schmitt trigger with Noise filter
P90-P92 TB6OUT TB7OUT TB8OUT	3	Input/output Output Output Output	Port 9: Input/output port (with pull-up) that allows input/output to be set in units of bits 16-bit timer 6 output: Pin for outputting a 16-bit timer 6 16-bit timer 7 output: Pin for outputting a 16-bit timer 7 16-bit timer 8 output: Pin for outputting a 16-bit timer 8
P93 TXD2	1	Input/output Output	Port 93: Input/output port (with pull-up) Sending serial data 2: Open drain output pin depending on the program used
P94 RXD2	1	Input/output Input	Port 94: Input/output port (with pull-up) Receiving serial data 2
P95 SCLK2 CTS2	1	Input/output Input/output Input	Port 95: Input/output port (with pull-up) Serial clock input/output 2 Handshake input pin Open drain output pin depending on the program used
P96,P97 TB9OUT TBAOUT	2	Input/output Output Output	Ports 96 and 97: Input/output port (with pull-up) that allows input/output to be set in units of bits 16-bit timer 9 output: Pin for outputting a 16-bit timer 9 16-bit timer A output: Pin for outputting a 16-bit timer A
PA0 TB6IN0 INT0	1	Input/output Input Input	Port A0: Input/output port (with pull-up) 16-bit timer 6 input 0: For inputting the capture trigger of a 16-bit timer 6 Interrupt request pin 0: Selectable between "H" level, "L" level, rising edge, falling edge, and both rising and falling edges. Input pin with Schmitt trigger with Noise filter
PA1 TB6IN1 INT1	1	Input/output Input Input	Port A1: Input/output port (with pull-up) 16-bit timer 6 input 1: For inputting the capture trigger of a 16-bit timer 6 Interrupt request pin 1: Selectable between "H" level, "L" level, rising edge, falling edge, and both rising and falling edges Input pin with Schmitt trigger with Noise filter
PA2 TB7IN0 INT2	1	Input/output Input Input	Port A2: Input/output port (with pull-up) 16-bit timer 7 input 0: For inputting the capture trigger of a 16-bit timer 7 Interrupt request pin 0: Selectable between "H" level, "L" level, rising edge, falling edge, and both rising and falling edges. Input pin with Schmitt trigger with Noise filter
PA3 TB7IN1 INT3	1	Input/output Input Input	Port A3: Input/output port (with pull-up) 16-bit timer 7 input 1: For inputting the capture trigger of a 16-bit timer 7 Interrupt request pin 1: Selectable between "H" level, "L" level, rising edge, falling edge, and both rising and falling edges. Input pin with Schmitt trigger with Noise filter

Table 2-5 Pin Names and Functions (4 of 6)

Pin name	Number of pins	Input or output	Function
PA4 TB8IN0 INT4	1	Input/output Input Input	Port A4: Input/output port (with pull-up) 16-bit timer 8 input 0: For inputting the capture trigger of a 16-bit timer 8 Interrupt request pin 0: Selectable between "H" level, "L" level, rising edge, falling edge, and both rising and falling edges Input pin with Schmitt trigger with Noise filter
PA5 TB8IN1 INT5	1	Input/output Input Input	Port A5: Input/output port (with pull-up) 16-bit timer 8 input 1: For inputting the capture trigger of a 16-bit timer 8 Interrupt request pin 1: Selectable between "H" level, "L" level, rising edge, falling edge, and both rising and falling edges Input pin with Schmitt trigger with Noise filter
PA6 TB2IN0	1	Input/output Input	Port A6: Input/output port (with pull-up) 16-bit timer 2 input 0: For inputting the capture trigger of a 16-bit timer 2
PA7 TB2IN1		Input/output Input	Port A7: Input/output port (with pull-up) 16-bit timer 2 input 1: For inputting the capture trigger of a 16-bit timer 2
PB0 TB3IN0	1	Input/output Input	Port B0: Input/output port (with pull-up) 16-bit timer 3 input 0: For inputting the capture trigger of a 16-bit timer 3
PB1 TB3IN1	1	Input/output Input	Port B1: Input/output port (with pull-up) 16-bit timer 3 input 1: For inputting the capture trigger of a 16-bit timer 3
PB2 HTXD0	1	Input/output Output	Port B2: Input/output port (with pull-up) Sending serial data 0 at high speeds: Open drain output pin depending on the program used
PB3 HRXD0	1	Input/output Input	Port B3: Input/output port (with pull-up) Receiving serial data 0 at high speeds
PB4 HSCLK0 HCTS0	1	Input/output Input/output Input	Port B4: Input/output port (with pull-up) High-speed serial clock input/output 0 Handshake input pin: Open drain output pin depending on the program used
PB5 HTXD1	1	Input/output Output	Port B5: Input/output port (with pull-up) Sending serial data 1 at high speeds: Open drain output pin depending on the program used
PB6 HRXD1	1	Input/output Input	Port B6: Input/output port (with pull-up) Receiving serial data 1 at high speeds
PB7 HSCLK1 HCTS1	1	Input/output Input/output Input	Port B7: Input/output port (with pull-up) High-speed serial clock input/output 1 Handshake input pin: Open drain output pin depending on the program used
PC0 TBTIN KEY30	1	Input/output Input	Port C0: Input/output port (with pull-up) 32-bit time base timer input: For inputting a 32-bit time base timer KEY on wake up input 30: (Dynamic pull up is selectable) Input with Schmitt trigger with Noise filter
PC1-PC4 TCOUT0- TCOUT3	4	Input/output Output	Ports C1 to C4: Input/output ports (with pull-up) that allow input/output to be set in units of bits Outputting 32-bit timer if the result of a comparison is a match
PC5 SO SDA	1	Input/output Output Input/output	Port C5: Input/output port (with pull-up) Pin for sending data if the serial bus interface operates in the SIO mode Pin for sending and receiving data if the serial bus interface operates in the I2C mode Open drain output pin depending on the program used Input with Schmitt trigger
PC6 SI SCL	1	Input/output Input Input/output	Port C6: Input/output port (with pull-up) Pin for receiving data if the serial bus interface operates in the SIO mode Pin for inputting and outputting a clock if the serial bus interface operates in the I2C mode Open drain output pin depending on the program used Input with Schmitt trigger
PC7 SCK	1	Input/output Input/output	Port C7: Input/output port (with pull-up) Pin for inputting and outputting a clock if the serial bus interface operates in the SIO mode Open drain output pin depending on the program used

Table 2-6 Pin Names and Functions (5 of 6)

Pin name	Number of pins	Input or output	Function
PD0 HTXD2	1	Input/output Output	Port D0: Input/output port (with pull-up) Sending serial data 2 at high speeds: Open drain output pin depending on the program used
PD1 HRXD2	1	Input/output Input	Port D1: Input/output port (with pull-up) Receiving serial data 2 at high speeds
PD2 HCLK2 HCTS2	1	Input/output Input/output Input	Port D2: Input/output port (with pull-up) High-speed serial clock input/output 2 Handshake input pin: Open drain output pin depending on the program used
PD3-PD5 TBBOUT- TBDOUT	3	Input/output Output	Ports D3 to D5: Input/output ports (with pull-up) that allow input/output to be set in units of bits 16-bit timers B, C and D outputs: Pin for outputting 16-bit timers B, C and D
PD6 ADTRG KEY31	1	Input/output Input Input	Port D6: Input/output port (with pull-up) that allows input/output to be set in units of bits Pin (with Schmitt trigger) for starting A/D trigger or A/D converter from an external source KEY on wake up input 31: (Dynamic pull up is selectable) Input with Schmitt trigger with Noise filter
PE0-PE7 KEY08-KEY15	8	Input/output Input	Port E: Input/output port (with pull-up) that allows input/output to be set in units of bits KEY on wake up input 08 to 15: (Dynamic pull up is selectable) Input with Schmitt trigger with Noise filter
PF0,PF2 DREQ0,4 KEY16,KEY18	2	Input/output Input Input	Port F: Input/output port (with pull-up) that allows input/output to be set in units of bits DMA request signals 0 and 4: For inputting the request to transfer data by DMA from an external I/O device to DMAC0 or DMAC4 KEY on wake up input 16 to 19: (Dynamic pull up is selectable) Input with Schmitt trigger with Noise filter
PF1,PF3 DACK0,4 KEY17,KEY19	2	Input/output Output Input	Port F: Input/output port (with pull-up) that allows input/output to be set in units of bits DMA acknowledge signals 0 and 4: Signal showing that DREQ0 and DREQ4 have acknowledged a DMA transfer request KEY on wake up input 16 to 19: (Dynamic pull up is selectable) Input with Schmitt trigger with Noise filter
PF4-PF7 KEY20-KEY23 TCOUT4- TCOUT7	4	Input/output Input Output	Port F: Input/output port (with pull-up) that allows input/output to be set in units of bits KEY on wake up input 20 to 23: (Dynamic pull up is selectable) Input with Schmitt trigger Outputting 32-bit timer if the result of a comparison is a match with Noise filter
PG0-PG7 TPD0-TPD7	8	Input/output Output	Port G: Input/output port (with pull-up) that allows input/output to be set in units of bits Outputting trace data from the data access address: Signal for DSU-ICE
PH0-PH7 TPC0-TPC7 TPD0-TPD7	8	Input/output Output Output	Port H: Input/output port (with pull-up) that allows input/output to be set in units of bits Outputting trace data from the program counter: Signal for DSU-ICE Outputting trace data from the data access address: Signal for DSU-ICE
DCLK	1	Output	Debug clock: Signal for DSU-ICE
EJE	1	Input	DSU-ICE enable: Signal for DSU-ICE (with Schmitt trigger) (with pull-up) with Noise filter
PCST4-0	4	Output	PC trace status: Signal for DSU-ICE
DINT	1	Input	Debug interrupt: Signal for DSU-ICE (input with Schmitt trigger and pull-up) with Noise filter
TOVR/TSR	1	Output	Outputting the status of PD data overflow status: Signal for DSU-ICE
TCK	1	Input	Test clock input: Signal for testing DSU-ICE (with Schmitt trigger and pull-up) with Noise filter
TMS	1	Input	Test mode select input: Signal for testing DSU-ICE (with Schmitt trigger and pull-up)
TDI	1	Input	Test data input E: Signal for testing JTAG (with Schmitt trigger and pull-up)
TDO	1	Output	Test data output: Signal for testing DSU-ICE
TRST	1	Input	Test reset input: Signal for testing DSU-ICE (with Schmitt trigger and pull-down) with Noise filter
RESET	1	Input	Reset: Initializing LSI (with pull-up) Input with Schmitt trigger with Noise filter
X1/X2	2	Input/output	Pin for connecting a high-speed oscillator (X1: Input with Schmitt trigger)
XT1/XT2	2	Input/output	Pin for connecting a low-speed oscillator (XT1: Input with Schmitt trigger)

Table 2-7 Pin Names and Functions (6 of 6)

Pin name	Number of pins	Input or output	Function
BOOT	1	Input	Pin for setting a single boot mode: This pin goes into single boot mode by sampling "L" at the rise of a reset signal. It is used to overwrite internal flash memory. By sampling "H (DVCC3) level" at the rise of a reset signal, it performs a normal operation. This pin should be pulled up under normal operating conditions. Pull it up when resetting. (With pull-up)
VREFH	1	Input	Pin (H) for supplying the A/D converter with a reference power supply Connect this pin to AVCC3 if the A/D converter is not used.
AVCC3	1	–	Pin for supplying the A/D converter with a power supply. Connect it to a power supply even if the A/D converter is not used.
AVSS	1	–	A/D converter GND pin (0 V). Connect this pin to GND even if the A/D converter is not used. Pin (L) for supplying the A/D converter with a reference power supply
TEST0	1	Input	TEST pin: To be fixed to DVCC3 (with Schmitt trigger)
TEST1	1	Input	TEST pin: To be fixed to DVCC3
TEST2	1	Input	TEST pin: Set to OPEN.
TEST3	1	Input	TEST pin: Set to OPEN.
TEST4	1	Input	TEST pin: Set to OPEN.
CVCH	1	–	Pin for supplying a high-frequency oscillator with power: 1.5 V power supply
CVCL	1	–	Pin for supplying a low-frequency oscillator with power: 3 V power supply
CVSS	1	–	Oscillator GND pin (0 V)
DVCC15	3	–	Power supply pin: 1.5 V power supply
DVCC3	4	–	Power supply pin: 3 V power supply
DVSS	5	–	Power supply pin: GND pin (0 V)
DAVCC	1	–	Power supply pin for the D/A converter: 2.5 V power supply If the D/A converter is not used, connect (fix) this pin to GND.
CVREF	1	–	Reference power supply pin for the D/A converter If the D/A converter is not used, connect (fix) this pin to GND.
DAGND	1	–	GND pin (0 V) for the D/A converter Connect this pin to GND even if the D/A converter is not used.
CVREF0	1	–	Pin for connecting a stabilizing capacitor to the D/A converter
CVREF1	1	–	Pin for connecting a stabilizing capacitor to the D/A converter
DA0	1	Output	D/A converter 0 output pin
DA1	1	Output	D/A converter 1 output pin

2.4 Pin Names and Power Supply Pins

Table 2-8 Pin Names and Power Supplies

Pin name	Power supply	Pin name	Power supply
P0	DVCC3	PCST4-0	DVCC3
P1	DVCC3	DCLK	DVCC3
P2	DVCC3	\overline{EJE}	DVCC3
P3	DVCC3	\overline{TRST}	DVCC3
P4	DVCC3	TDI	DVCC3
P5	DVCC3	TDO	DVCC3
P6	DVCC3	TMS	DVCC3
P7	AVCC3	TCK	DVCC3
P8	AVCC3	\overline{DINT}	DVCC3
P9	DVCC3	TOVR/TSTA	DVCC3
PA	DVCC3	BUSMD	DVCC3
PB	DVCC3	BOOT	DVCC3
PC	DVCC3	X1, X2	CVCCH
PD	DVCC3	XT1, XT2	CVCLL
PE	DVCC3	\overline{RESET}	DVCC3
PF	DVCC3	DA0,1	DAVCC
PG	DVCC3		
PH	DVCC3		

2.5 Pin Numbers and Power Supply Pins

Table 2-9 Pin Numbers and Power Supplies

Power supply	Pin number	Voltage range
DVCC15	J5, K13, N10	1.35 V to 1.65 V
DVCC3	E11, H5	1.65 V to 3.6 V
AVCC3	F6	2.7 V to 3.6 V
FVCC3	M13, N8	2.7 V to 3.6 V
CVCCH	A16	1.35 V to 1.65 V
CVCLL	B17	2.7 V to 3.6 V
DAVCC	E8	2.3 V to 2.7 V

3. Flash Memory Operation

This section describes the hardware configuration and operation of the flash memory. The feature of this device is that the internal ROM of TMP19A43CDXBG is replaced by an internal flash memory. Other configurations and functions of the device remain the same as with TMP19A43CDXBG. Please refer to the TMP19A43CDXBG data sheet for functions not described in this section.

3.1 Flash Memory

3.1.1 Features

1) Memory size

The TMP19A43FDXBG device contains 4M bits (512 kB) of flash memory. The memory area consists of 4 independent memory blocks (128 kB × 4) to enable independent write access to each block. When the CPU is to access the internal flash memory, 32-bit data bus width is used.

2) Flash memory access

Interleave access is used in this device.

3) Write/erase time

Write time: 2 sec/Chip (Typ) 0.5 sec/128 Kbyte (Typ.)

Erase: 0.4 sec/Chip (Typ) 100 msec/128 Kbyte (Typ.)

(Note) The above values are theoretical values not including data transfer time.

The write time per chip depends on the write method to be used by the user.

4) Programming method

The onboard programming mode is available for the user to program (rewrite) the device while it is mounted on the user's board.

4-1) User boot mode

The user's original rewriting method can be supported.

4-2) Single boot mode

The rewriting method to use serial data transfer (Toshiba's unique method) can be supported.

Rewriting method

The flash memory included in this device is generally compliant with the applicable JEDEC standards except for some specific functions. Therefore, if the user is currently using an external flash memory device, it is easy to implement the functions into this device. Furthermore, the user is not required to build his/her own programs to realize complicated write and erase functions because such functions are automatically performed using the circuits already built-in the flash memory chip.

This device is also implemented with a read-protect function to inhibit reading flash memory data from any external writer device. On the other hand, rewrite protection is available only through command-based software programming; any hardware setting method to apply +12VDC is not supported. The above described protection function is automatically enabled when all the four area are configured for protection. When the user removes protection, the internal data is automatically erased before the protection is actually removed.

JEDEC compliant functions	Modified, added, or deleted functions
<ul style="list-style-type: none"> • Automatic programming • Automatic chip erase • Automatic block erase • Data polling/toggle bit 	<p><Modified> Block protect (only software protection is supported)</p> <p><Deleted> Erase resume - suspend function</p> <p>Automatic multiple block erase (supported to the chip level)</p>

3.1.2 Block Diagram of the Flash Memory Section

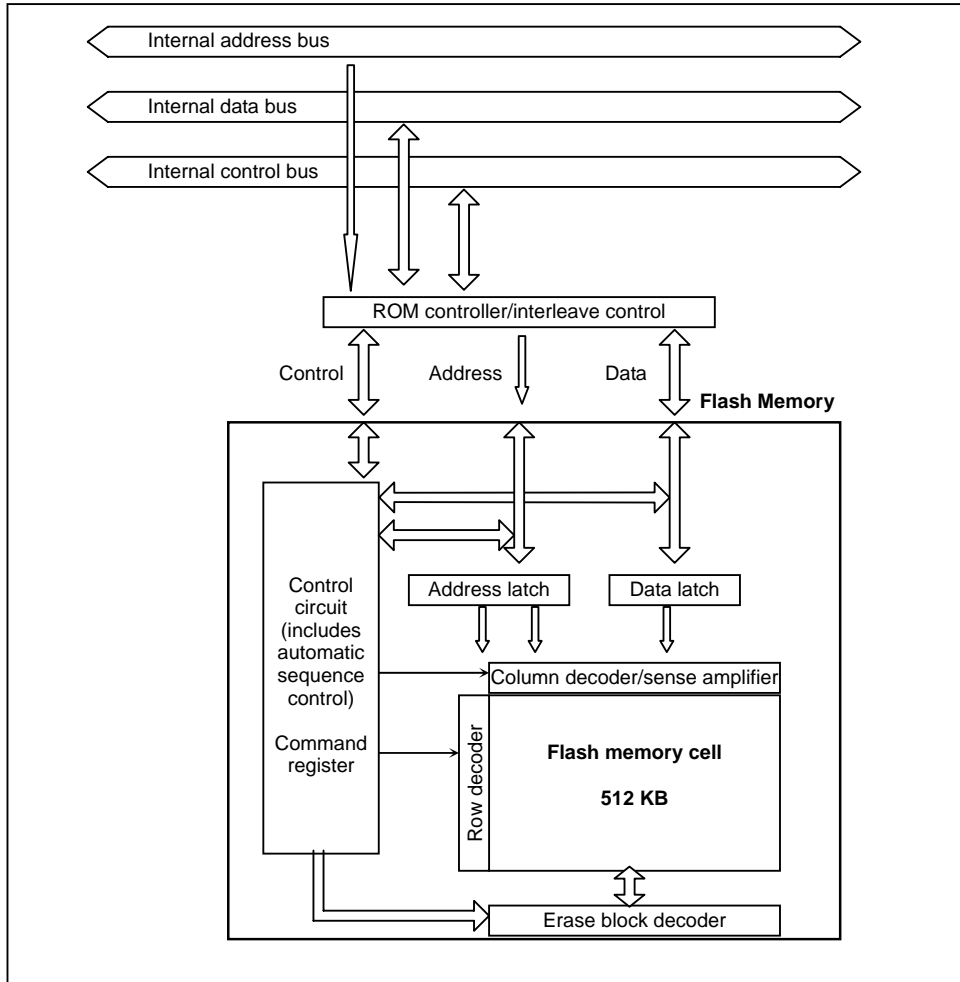

Fig. 3-1 Block Diagram of the Flash Memory Section

3.2 Operation Mode

This device has three operation modes including the mode not to use the internal flash memory.

Table 3-1 Operation Modes

Operation mode	Operation details
Single chip mode	After reset is cleared, it starts up from the internal flash memory.
Normal mode	In this operation mode, two different modes, i.e., the mode to execute user application programs and the mode to rewrite the flash memory onboard the user's card, are defined. The former is referred to as "normal mode" and the latter "user boot mode."
User boot mode	The user can uniquely configure the system to switch between these two modes. For example, the user can freely design the system such that the normal mode is selected when the port "00" is set to "1" and the user boot mode is selected when it is set to "0." The user should prepare a routine as part of the application program to make the decision on the selection of the modes.
Single boot mode	After reset is cleared, it starts up from the internal Boot ROM (Mask ROM). In the Boot ROM, an algorithm to enable flash memory rewriting on the user's set through the serial port of this device is programmed. By connecting to an external host computer through the serial port, the internal flash memory can be programmed by transferring data in accordance with predefined protocols.

Among the flash memory operation modes listed in the above table, the User Boot mode and the Single Boot mode are the programmable modes. These two modes, the User Boot mode and the Single Boot mode, are referred to as "Onboard Programming" modes where onboard rewriting of internal flash memory can be made on the user's card.

Either the Single Chip or Single Boot operation mode can be selected by externally setting the level of the $\overline{\text{BOOT}}$ input pin while the device is in reset status.

After the level is set, the CPU starts operation in the selected operation mode when the reset condition is removed. Regarding the TEST0, TEST1, and BOOT pins, be sure not to change the levels during operation once the mode is selected.

The mode setting method and the mode transition diagram are shown below:

Table 3-2 Operation Mode Setting

Operation mode	Input pin	
	$\overline{\text{RESET}}$	$\overline{\text{BOOT}}$
Single chip mode	0 to 1	1
Single boot mode	0 to 1	0

Fig. 3-2 Mode Transition Diagram

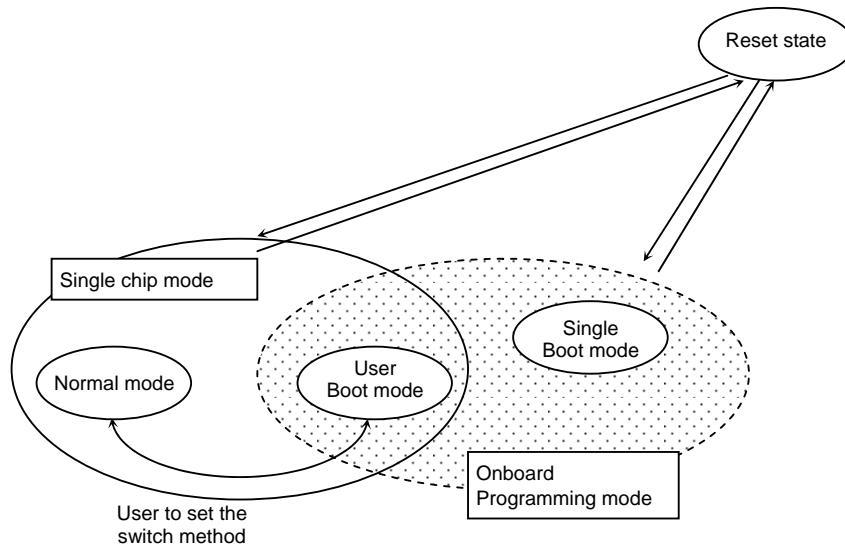

3.2.1 Reset Operation

To reset the device, ensure that the power supply voltage is within the operating voltage range, that the internal oscillator has been stabilized, and that the $\overline{\text{RESET}}$ input is held at "0" for a minimum duration of 12 system clocks (2.4 μs with 40MHz operation; the "1/8" clock gear mode is applied after reset).

- (Note 1) Regarding power-on reset of devices with internal flash memory;**
 For devices with internal flash memory, it is necessary to apply "0" to the $\overline{\text{RESET}}$ inputs upon power on for a minimum duration of 500 microseconds regardless of the operating frequency.
- (Note 2) While flash programming or deletion is in progress, at least 0.5 microseconds of reset period is required regardless of the system clock frequency.**

3.2.2 DSU (EJTAG) - PROBE Interface

This interface is used when the DSU probe is used in debugging. This is the dedicated interface for connection to the DSU probe. Please refer to the operation manual for the DSU probe you are going to use for details of debugging procedures to use the DSU probe. Here, the function to enable/disable the DSU probe in the DSU (EJTAG) mode is described.

1) Protect function

This device allows use of on-board DSU probes for debugging. To facilitate this, the device is implemented with a protection function to prevent easy reading of the internal flash memory by a third party other than the authorized user. By enabling the protection function, it becomes impossible to read the internal flash memory from a DSU probe. Use this function together with the protection function of the internal flash memory itself as described later.

2) DSU probe enable/disable function

This device allows use of on-board DSU probes for debugging operations. To facilitate this, the device is implemented with the "DSU probe inhibit" function (hereafter referred to as the "**DSU inhibit**" function) to prevent easy reading of the internal flash memory by a third party other than the authorized user. By enabling the DSU inhibit function, use of any DSU probe becomes impossible.

3) DSU enable (Enables use of DSU probes for debugging)

In order to prevent the DSU inhibit function from being accidentally removed by system runaway, etc., the method to cancel the DSU inhibit function is in double protection structure so it is necessary to set SEQMOD <DSUOFF> to "0" and also write the protect code "0x0000_00C5" to the DSU protect control register SEQCNT to cancel the function. Then, debugging to use a DSU probe can be allowed. While power to the device is still applied, setting SEQMOD <SEQON> to "1" and writing "0x0000_00C5" to the SEQCNT register will enable the protection function again.

Table 3-3 DSU Protect Mode Register

	7	6	5	4	3	2	1	0
Bit Symbol								DSUOFF
Read/Write	R							R/W
After reset	0							1
Function	Always reads "0."							1: DSU disable 0: DSU available
	15	14	13	12	11	10	9	8
Bit Symbol								
Read/Write	R							
After reset	0							
Function	Always reads "0."							
	23	22	21	20	19	18	17	16
Bit Symbol								
Read/Write	R							
After reset	0							
Function								
	31	30	29	28	27	26	25	24
Bit Symbol								
Read/Write	R							
After reset	0							
Function	Always reads "0."							

(Note) This register must be 32-bit accessed.

(note) This register is initialized only by power-on reset. It is not initialized in reset usually. (FLASH)

Table 3-4 DSU Protect Control Register

	7	6	5	4	3	2	1	0
SEQCNT (0xFFFF_E514)	Bit Symbol							
	Read/Write							
	After reset							
	Function							
	Write "0x0000_00C5."							
	15	14	13	12	11	10	9	8
	Bit Symbol							
	Read/Write							
	After reset							
	Function							
	Write "0x0000_00C5."							
	23	22	21	20	19	18	17	16
	Bit Symbol							
	Read/Write							
	After reset							
	Function							
	Write "0x0000_00C5."							
	31	30	29	28	27	26	25	24
	Bit Symbol							
	Read/Write							
	After reset							
	Function							
	Write "0x0000_00C5."							

(Note 1) This register must be 32-bit accessed.

4) Example use by the user

An example to use a DSU probe together with this function is shown as follows:

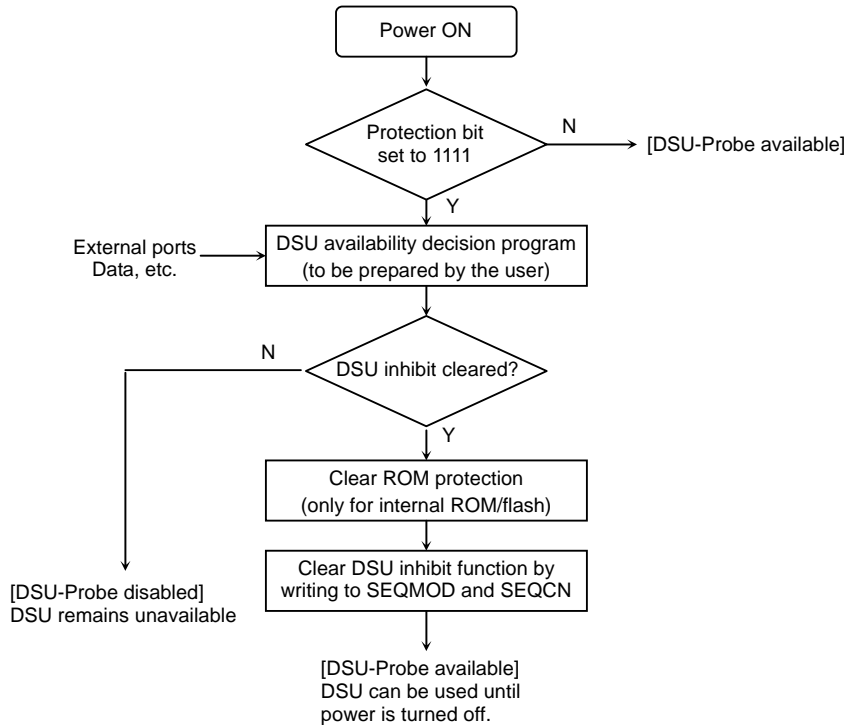
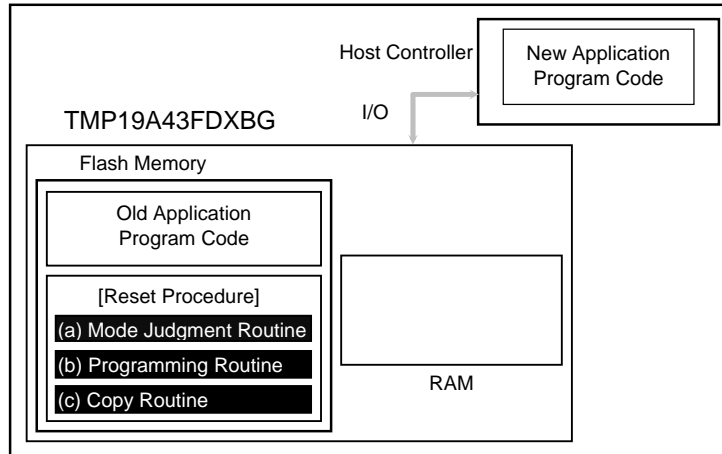

Figure 3-3 Example Use of DSU Inhibit Function

User Boot Mode

(1-A) Method 1: Storing a Programming Routine in the Flash Memory

- (1) Determine the conditions (e.g., pin states) required for the flash memory to enter User Boot mode and the I/O bus to be used to transfer new program code. Create hardware and software accordingly. Before installing the TMP19A43FDXBG on a printed circuit board, write the following program routines into an arbitrary flash block using programming equipment.
 - Mode judgment routine: Code to determine whether or not to switch to User Boot mode
 - Programming routine: Code to download new program code from a host controller and re-program the flash memory
 - Copy routine: Code to copy the flash programming routine from the TMP19A43FDXBG flash memory to either the TMP19A43FDXBG on-chip RAM or external memory device.



- (2) After $\overline{\text{RESET}}$ is released, the reset procedure determines whether to put the TMP19A43FDXBG flash memory in User Boot mode. If mode switching conditions are met, the flash memory enters User Boot mode. (All interrupts including NMI must be globally disabled while in User Boot mode.)

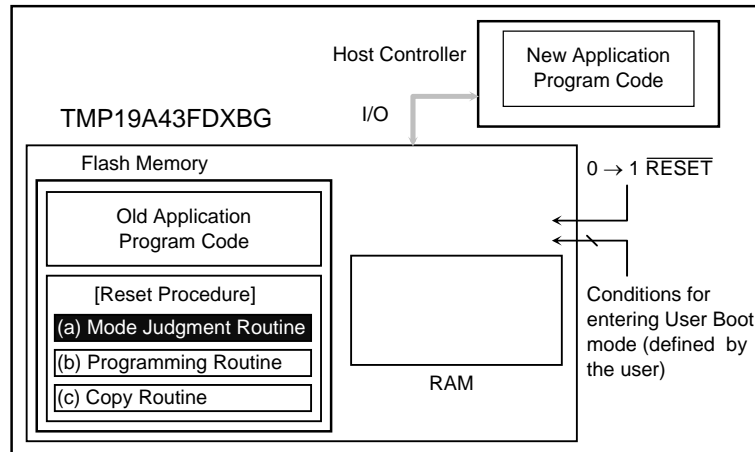

- (3) Once User Boot mode is entered, execute the copy routine to copy the flash programming routine to either the TMP19A43FDXBG on-chip RAM or an external memory device. (In the following figure, the on-chip RAM is used.)

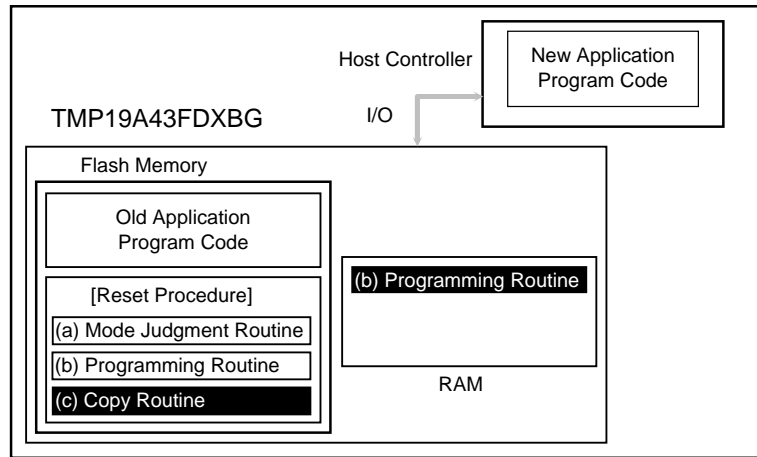

- (4) Jump program execution to the flash programming routine in the on-chip RAM to erase a flash block containing the old application program code.

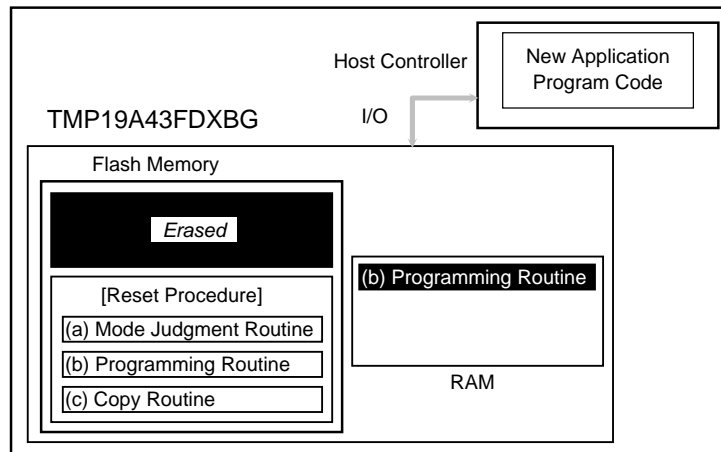

- (5) Continue executing the flash programming routine to download new program code from the host controller and program it into the erased flash block. Once programming is complete, turn on the protection of that flash block.

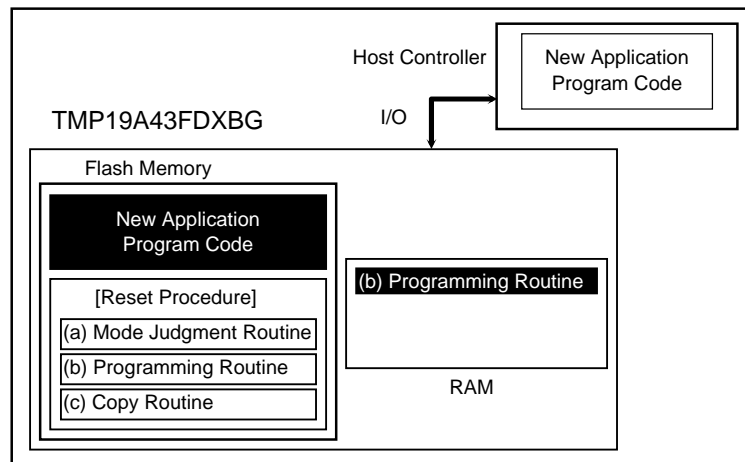

- (6) Drive $\overline{\text{RESET}}$ low to reset the TMP19A43FDXBG. Upon reset, the on-chip flash memory is put in Normal mode. After $\overline{\text{RESET}}$ is released, the CPU will start executing the new application program code.

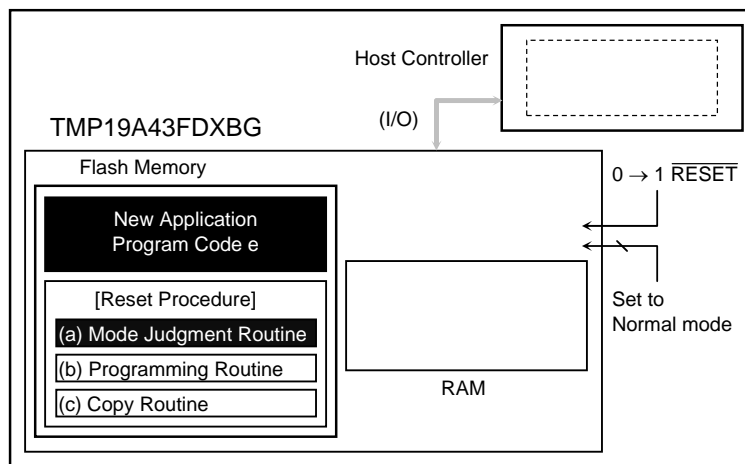

(1-B) Method 2: Transferring a Programming Routine from an External Host

- (1) Determine the conditions (e.g., pin states) required for the flash memory to enter User Boot mode and the I/O bus to be used to transfer new program code. Create hardware and software accordingly. Before installing the TMP19A43FDXBG on a printed circuit board, write the following program routines into an arbitrary flash block using programming equipment.

Mode judgment routine: Code to determine whether or not to switch to User Boot mode

Transfer routine: Code to download new program code from a host controller

Also, prepare a programming routine on the host controller:

Programming routine: Code to download new program code from an external host controller and re-program the flash memory

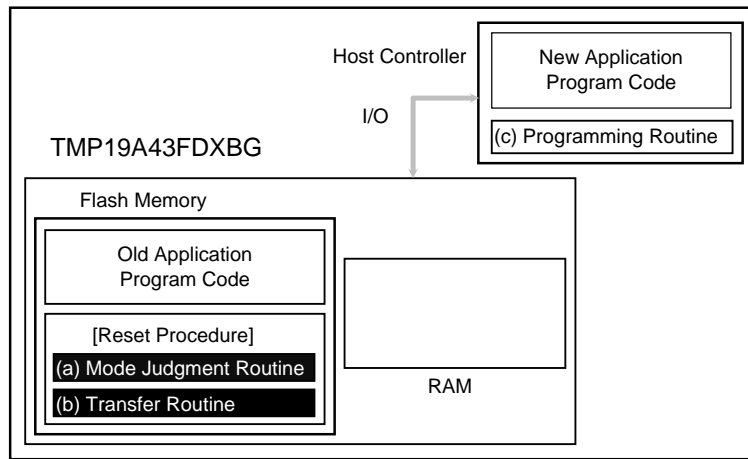

- (2) After $\overline{\text{RESET}}$ is released, the reset procedure determines whether to put the TMP19A43FDXBG flash memory in User Boot mode. If mode switching conditions are met, the flash memory enters User Boot mode. (All interrupts including NMI must be globally disabled while in User Boot mode.)

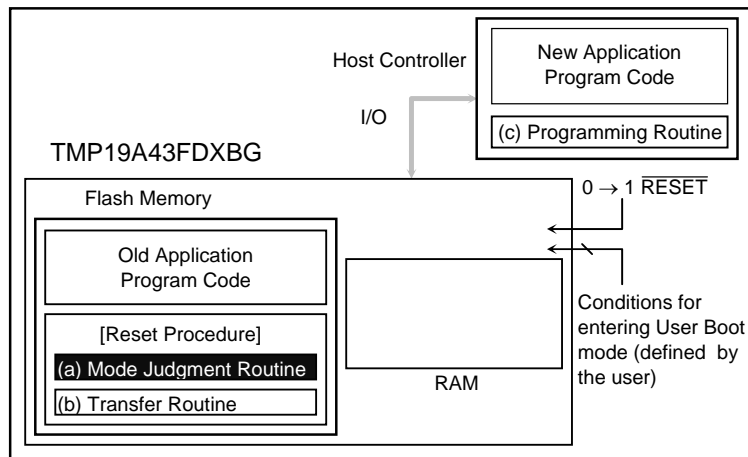

- (3) Once User Boot mode is entered, execute the transfer routine to download the flash programming routine from the host controller to either the TMP19A43FDXBG on-chip RAM or an external memory device. (In the following figure, the on-chip RAM is used.)

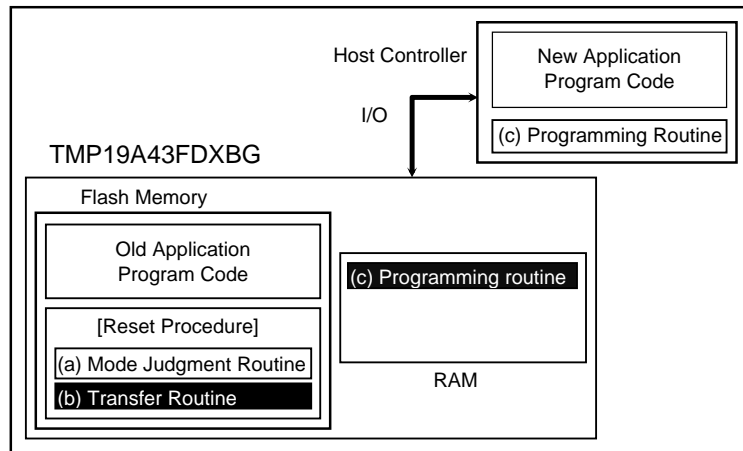

- (4) Jump program execution to the flash programming routine in the on-chip RAM to erase a flash block containing the old application program code.

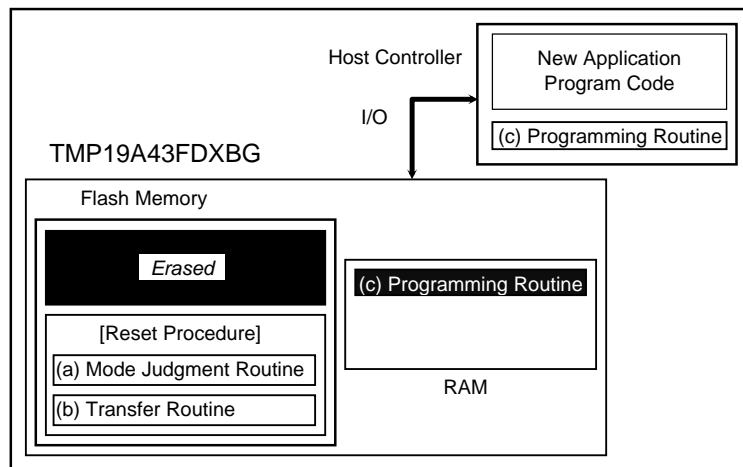

- (5) Continue executing the flash programming routine to download new program code from the host controller and program it into the erased flash block. Once programming is complete, turn on the protection of that flash block.

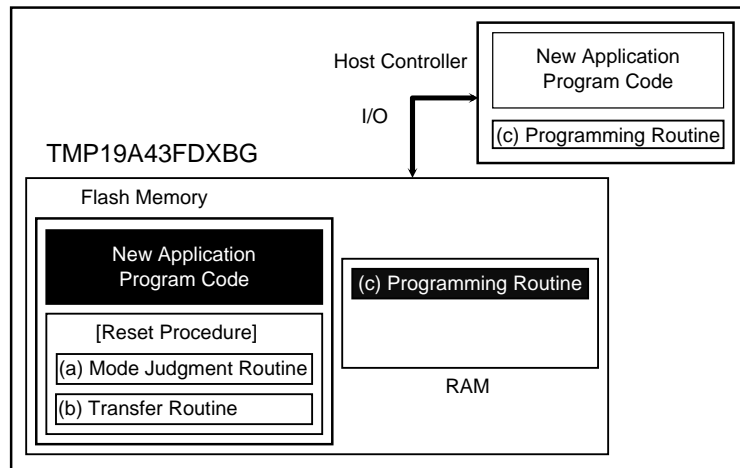

Drive $\overline{\text{RESET}}$ low to reset the TMP19A43FDXBG. Upon reset, the on-chip flash memory is put in Normal mode. After $\overline{\text{RESET}}$ is released, the CPU will start executing the new application program code.

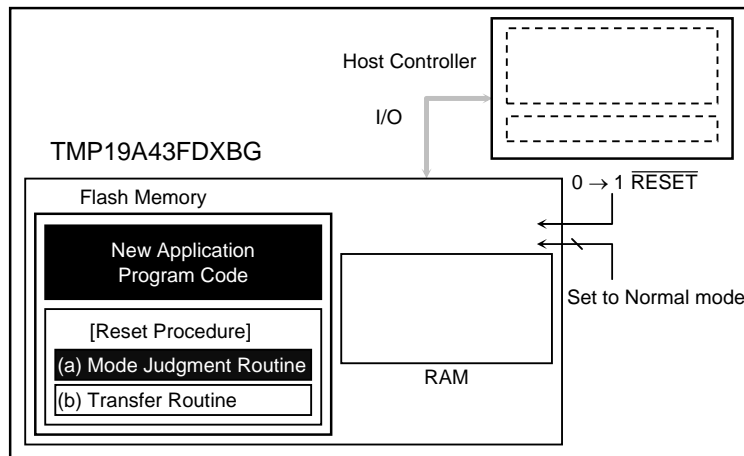

3.3 Single Boot Mode

In Single Boot mode, the flash memory can be re-programmed by using a program contained in the TMP19A43FDXBG on-chip boot ROM. This boot ROM is a masked ROM. When Single Boot mode is selected upon reset, the boot ROM is mapped to the address region including the interrupt vector table while the flash memory is mapped to an address region different from it.

Single Boot mode allows for serial programming of the flash memory. Channel 0 of the SIO (SIO0) of the TMP19A43FDXBG is connected to an external host controller. Via this serial link, a programming routine is downloaded from the host controller to the TMP19A43FDXBG on-chip RAM. Then, the flash memory is re-programmed by executing the programming routine. The host sends out both commands and programming data to re-program the flash memory.

Communications between the SIO0 and the host must follow the protocol described later. To secure the contents of the flash memory, the validity of the application's password is checked before a programming routine is downloaded into the on-chip RAM. If password matching fails, the transfer of a programming routine itself is aborted.

As in the case of User Boot mode, all interrupts including the nonmaskable (NMI) interrupt must be globally disabled in Single Boot mode while the flash memory is being erased or programmed. In Single Boot mode, the boot-ROM programs are executed in Normal mode.

Once re-programming is complete, it is recommended to protect relevant flash blocks from accidental corruption during subsequent Single-Chip (Normal mode) operations. For a detailed description of the erase and program sequence, refer to On-Board Programming and Erasure.

Boot Mode

(2-A) General Procedure: Using the Program in the On-Chip Boot ROM

- (1) The flash block containing the older version of the program code need not be erased before executing the programming routine. Since a programming routine and programming data are transferred via the SIO0, the SIO0 must be connected to a host controller. Prepare a programming routine on the host controller.

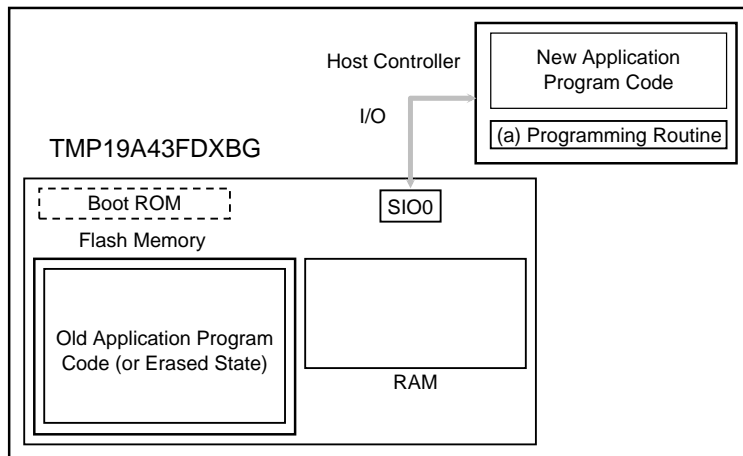

- (2) Reset the TMP19A43FDXBG with the mode setting pins held at appropriate logic values, so that the CPU re-boots from the on-chip boot ROM. The 12-byte password transferred from the host controller is first compared to the contents of special flash memory locations. (If the flash block has already been erased, the password is 0xFFFF.)

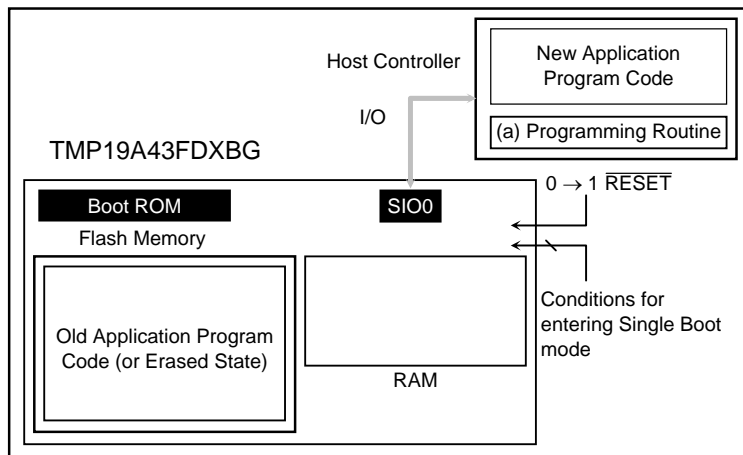

If the password was correct, the boot program downloads, via the SIO0, the programming routine from the host controller into the on-chip RAM of the TMP19A43FDXBG. The programming routine must be stored in the address range 0xFFFFD_6000 – 0xFFFFD_EFFF.

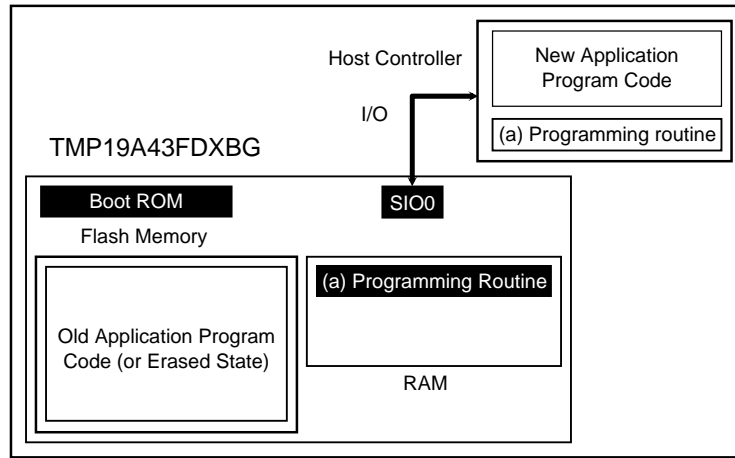

- (3) The CPU jumps to the programming routine in the on-chip RAM to erase the flash block containing the old application program code. The Block Erase or Chip Erase command may be used.

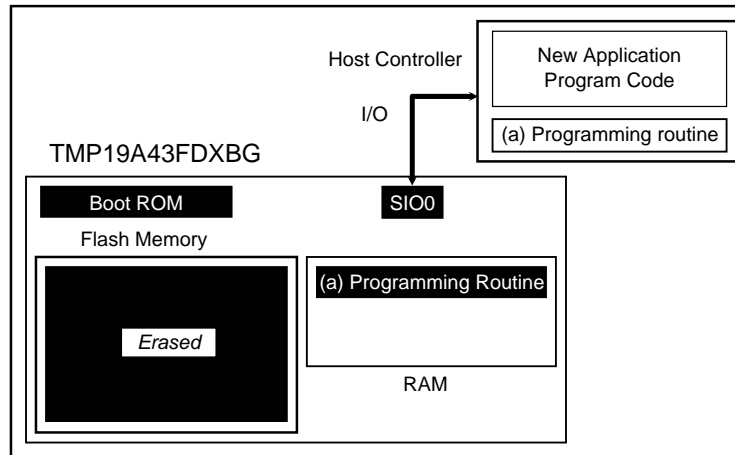

Next, the programming routine downloads new application program code from the host controller and programs it into the erased flash block. Once programming is complete, protection of that flash block is turned on.

It is not allowed to move program control from the programming routine back to the boot ROM.

In the example below, new program code comes from the same host controller via the same SIO channel as for the programming routine. However, once the programming routine has begun to execute, it is free to change the transfer path and the source of the transfer. Create board hardware and a programming routine to suit your particular needs.

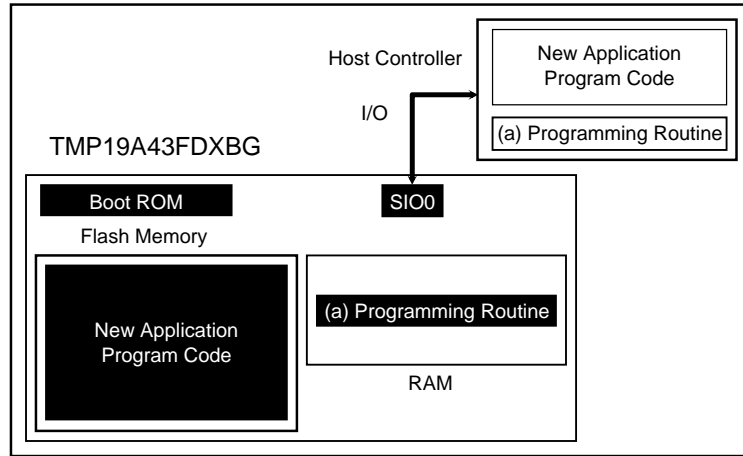

- (4) When programming of the flash memory is complete, power off the board and disconnect the cable leading from the host to the target board. Turn on the power again so that the TMP19A43FDXBG re-boots in Single-Chip (Normal) mode to execute the new program.

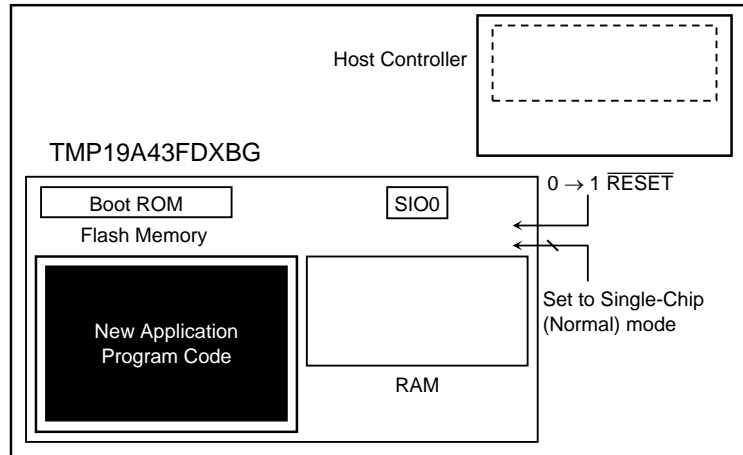

3.3.1 Configuring for Single Boot Mode

For on-board programming, boot the TMP19A43FDXBG in Single Boot mode, as follows:

$$\overline{\text{BOOT}} = 0$$

$$\overline{\text{RESET}} = 0 \rightarrow 1$$

Set the $\overline{\text{RESET}}$ input at logic 0, and the BW0, BW1 and $\overline{\text{BOOT}}$ inputs at the logic values shown above, and then release $\overline{\text{RESET}}$ (high).

3.3.2 Memory Map

Figure 3.1 shows a comparison of the memory maps in Normal and Single Boot modes. In single Boot mode, the on-chip flash memory is mapped to physical addresses (0x4000_0000 through 0x4007_FFFF), virtual addresses (0x0000_0000 through 0x0007_FFFF), and the on-chip boot ROM is mapped to physical addresses 0x1FC0_0000 through 0x1FC0_1FFF.

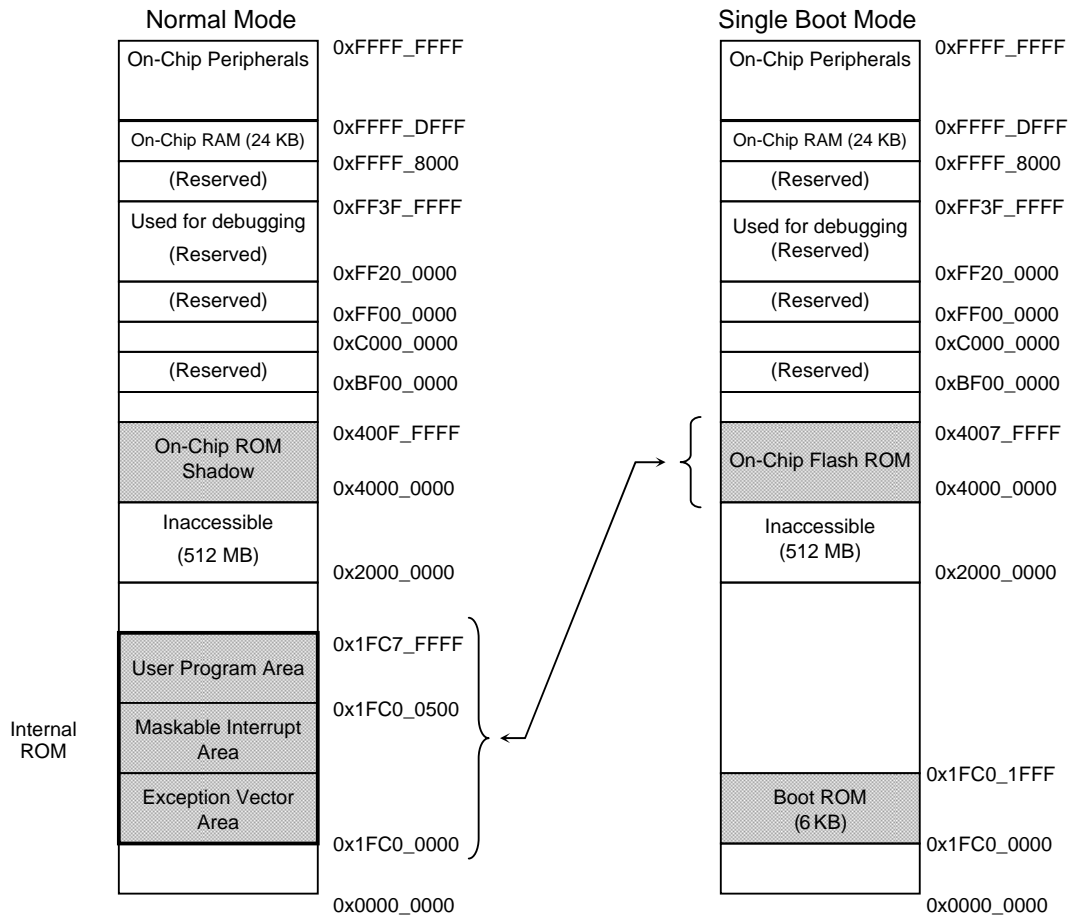

Figure 3.1 Memory Maps for Normal and Single Boot Modes (Physical Addresses)

3.3.3 Interface Specification

In Single Boot mode, an SIO channel is used for communications with a programming controller. Both UART (asynchronous) and I/O Interface (synchronous) modes are supported. The communication formats are shown below. In the subsections that follow, virtual addresses are indicated, unless otherwise noted.

- UART mode
 - Communication channel: SIO Channel 0 (SIO0)
 - Transfer mode: UART (asynchronous) mode, full-duplex
 - Data length: 8 bits
 - Parity bits: None
 - STOP bits: 1
 - Baud rate: Arbitrary baud rate

- I/O Interface mode
 - Communication channel: SIO Channel 0 (SIO0)
 - Transfer mode: I/O Interface mode, half-duplex
 - Synchronization clock (SCLK0): Input
 - Handshaking signal: P67 configured as an output
 - Baud rate: Arbitrary baud rate

Table 3.1 Required Pin Connections

Pin		Interface	
		UART Mode	I/O Interface Mode
Power Supply Pins	DVCC15	Required	Required
	DVSS	Required	Required
Mode-Setting Pin	$\overline{\text{BOOT}}$	Required	Required
Reset Pin	$\overline{\text{RESET}}$	Required	Required
Communication Pins	TXD0	Required	Required
	RXD0	Required	Required
	SCLK0	Not Required	Required (Input Mode)
	P67	Not Required	Required (OUTPUT Mode)

3.3.4 Data Transfer Format

The host controller is to issue one of the commands listed in Table 3.2 to the target board. Table 3.3 to Table 3.5 illustrate the sequence of two-way communications that should occur in response to each command.

Table 3.2 Single Boot Mode Commands

Code	Command
10H	RAM Transfer
20H	Show Flash Memory Sum
30H	Show Product Information

Table 3.3 Transfer Format for the RAM Transfer Command

	Byte	Data Transferred from the Controller to the TMP19A43FDXBG	Baud Rate	Data Transferred from the TMP19A43FDXBG to the Controller
Boot ROM	1st byte	Serial operation mode and baud rate For UART mode 86H For I/O Interface mode 30H	Desired baud rate (Note 1)	—
	2nd byte	—		ACK for the serial operation mode byte For UART mode Normal acknowledge 86H (The boot program aborts if the baud rate is can not be set correctly.) For I/O Interface mode Normal acknowledge 30H
	3rd byte	Command code (10H)		—
	4th byte	—		ACK for the command code byte (Note 2) Normal acknowledge 30H Negative acknowledge x1H Communication error x8H
	5th byte thru 16th byte	Password sequence (12 bytes) (0x4000_0474 thru 0x4000_047F)		—
	17th byte	Checksum value for bytes 5–16		—
	18th byte	—		ACK for the checksum byte (Note 2) Normal acknowledge 10H Negative acknowledge x1H Communication error x8H
	19th byte	RAM storage start address (bits 31–24)		—
	20th byte	RAM storage start address (bits 23–16)		—
	21st byte	RAM storage start address (bits 15–8)		—
	22nd byte	RAM storage start address (bits 7–0)		—
	23rd byte	RAM storage byte count (bits 15–8)		—
	24th byte	RAM storage byte count (bits 7–0)		—
	25th byte	Checksum value for bytes 19–24		—
	26th byte	—		ACK for the checksum byte (Note 2) Normal acknowledge 10H Negative acknowledge x1H Communication error x8H
	27th byte thru mth byte	RAM storage data		—
	(m + 1)th byte	Checksum value for bytes 27–m		—
(m + 2)th byte	—	ACK for the checksum byte (Note 2) Normal acknowledge 10H Non-acknowledge x1H Communications error x8H		
RAM	(m + 3)th byte	—	Jump to RAM storage start address	

Note 1: In I/O Interface mode, the baud rate for the transfers of the first and second bytes must be 1/16 of the desired baud rate.

Note 2: In case of any negative acknowledge, the boot program returns to a state in which it waits for a command code (3rd byte). In I/O Interface mode, if a communication error occurs, a negative acknowledge does not occur.

Note 3: The 19th to 25th bytes must be within the RAM address range 0xFFFFD_8000–0xFFFF_CFFF

Table 3.4 Transfer Format for the Show Flash Memory Sum Command

	Byte	Data Transferred from the Controller to the TMP19A43FDXBG	Baud Rate	Data Transferred from the TMP19A43FDXBG to the Controller
Boot ROM	1st byte	Serial operation mode and baud rate For UART mode 86H For I/O Interface mode 30H	Desired baud rate (Note 1)	—
	2nd byte	—		ACK for the serial operation mode byte For UART mode Normal acknowledge 86H (The boot program aborts if the baud rate can not be set correctly.) For I/O Interface mode Normal acknowledge 30H
	3rd byte	Command code (20H)		—
	4th byte	—		ACK for the command code byte (Note 2) Normal acknowledge 20H Negative acknowledge x1H Communication error x8H
	5th byte	—		SUM (upper byte)
	6th byte	—		SUM (lower byte)
	7th byte	—		Checksum value for bytes 5 and 6
	8th byte	(Wait for the next command code.)		—

Note 1: In I/O Interface mode, the baud rate for the transfers of the first and second bytes must be 1/16 of the desired baud rate.

Note 2: In case of any negative acknowledge, the boot program returns to a state in which it waits for a command code (3rd byte). In I/O Interface mode, if a communication error occurs, a negative acknowledge does not occur.

Table 3.5 Transfer Format for the Show Product Information Command (1/2)

	Byte	Data Transferred from the Controller to the TMP19A43FDXBG	Baud Rate	Data Transferred from the TMP19A43FDXBG to the Controller
Boot ROM	1st byte	Serial operation mode and baud rate For UART mode 86H For I/O Interface mode 30H	Desired baud rate (Note 1)	—
	2nd byte	—		ACK for the serial operation mode byte For UART mode Normal acknowledge 86H (The boot program aborts if the baud rate can not be set correctly.) For I/O Interface mode Normal acknowledge 30H
	3rd byte	Command code (30H)		—
	4th byte	—		ACK for the command code byte (Note 2) Normal acknowledge 10H Negative acknowledge x1H Communication error x8H
	5th byte	—		Flash memory data (at address 0x4000_0470)
	6th byte	—		Flash memory data (at address 0x4000_0471)
	7th byte	—		Flash memory data (at address 0x4000_0472)
	8th byte	—		Flash memory data (at address 0x4000_0473)
	9th byte thru 20th byte	—		Product name (12-byte ASCII code) "TX19A43FD" from the 9th byte
	21st byte thru 24th byte	—		Password comparison start address (4 bytes) 74H, 04H, 00H and 00H from the 21st byte
	25th byte thru 28th byte	—		RAM start address (4 bytes) 00H, 80H, FFH and FFH from the 25th byte
	29th byte thru 32nd byte	—		Dummy data (4 bytes) FFH, 8FH, FFH and FFH from the 29th byte
	33rd byte thru 36th byte	—		RAM end address (4 bytes) FFH, DFH, FFH and FFH from the 33rd byte
	37th byte thru 40th byte	—		Dummy data (4 bytes) 00H,90H, FFH and FFH from the 37th byte
	41st byte thru 44th byte	—		Dummy data (4 bytes) FFH, CFH, FFH and FFH from the 41st byte
	45th byte thru 46th byte	—		Fuse information (2 bytes) 00H and 00H from the 45th byte
	47th byte thru 50th byte	—		Flash memory start address (4 bytes) 00H, 00H, 00H and 00H from the 47th byte
	51st byte thru 54th byte	—		Flash memory end address (4 bytes) FFH, FFH, 07H and 00H from the 51st byte
	55th byte thru 56th byte	—		Flash memory block count (2 bytes) 00H and 00H from at the 55th byte

Table 3.5 Transfer Format for the Show Product Information Command (2/2)

	Byte	Data Transferred from the Controller to the TMP19A43FDXBG	Baud Rate	Data Transferred from the TMP19A43FDXBG to the Controller
Boot ROM	57th byte thru 60th byte	—		Start address of a group of the same-size flash blocks (4 bytes) 00H, 00H, 00H and 00H from the 57th byte
	61st byte thru 64th byte	—		Size (in halfwords) of the same-size flash blocks (4 bytes) 00H, 00H, 01H and 00H from the 61st byte
	65th byte	—		Number of flash blocks of the same size (1 byte) 04H
	66th byte	—		Checksum value for bytes 5 to 65
	67th byte	(Wait for the next command code.)		—

Note 1: In I/O Interface mode, the baud rate for the transfers of the first and second bytes must be 1/16 of the desired baud rate.

Note 2: In case of any negative acknowledge, the boot program returns to a state in which it waits for a command code (3rd byte). In I/O Interface mode, if a communication error occurs, a negative acknowledge does not occur.

3.3.5 Overview of the Boot Program Commands

When Single Boot mode is selected, the boot program is automatically executed on startup. The boot program offers these three commands, the details of which are provided on the following subsections.

- RAM Transfer command

The RAM Transfer command stores program code transferred from a host controller to the on-chip RAM and executes the program once the transfer is successfully completed. The maximum program size is 36 kbytes. The RAM storage start address must be within the range.

The RAM Transfer command can be used to download a flash programming routine of your own; this provides the ability to control on-board programming of the flash memory in a unique manner. The programming routine must utilize the flash memory command sequences described in Section 3.6.17

Before initiating a transfer, the RAM Transfer command checks a password sequence coming from the controller against that stored in the flash memory. If they do not match, the RAM Transfer command aborts.

Once the RAM Transfer command is complete, the whole on-chip RAM is accessible.

- Show Flash Memory Sum command

The Show Flash Memory Sum command adds the contents of the 512 kbytes of the flash memory together. The boot program does not provide a command to read out the contents of the flash memory. Instead, the Flash Memory Sum command can be used for software revision management.

- Show Product Information command

The Show Product Information command provides the product name, on-chip memory configuration and the like. This command also reads out the contents of the flash memory locations at addresses 0x0000_03F0 through 0x0000_03F3. In addition to the Show Flash Memory Sum command, these locations can be used for software revision management.

3.3.6 RAM Transfer Command

See Table 3.3.

- (5) The 1st byte specifies which one of the two serial operation modes is used. For a detailed description of how the serial operation mode is determined, see Section 3.3.10. If it is determined as UART mode, the boot program then checks if the SIO0 is programmable to the baud rate at which the 1st byte was transferred. During the first-byte interval, the RXE bit in the SC0MOD register is cleared.
- To communicate in UART mode
Send, from the controller to the target board, 86H in UART data format at the desired baud rate. If the serial operation mode is determined as UART, then the boot program checks if the SIO0 can be programmed to the baud rate at which the first byte was transferred. If that baud rate is not possible, the boot program aborts, disabling any subsequent communications.
 - To communicate in I/O Interface mode
Send, from the controller to the target board, 30H in I/O Interface data format at 1/16 of the desired baud rate. Also send the 2nd byte at the same baud rate. Then send all subsequent bytes at a rate equal to the desired baud rate.
In I/O Interface mode, the CPU sees the serial receive pin as if it were a general input port in monitoring its logic transitions. If the baud rate of the incoming data is high or the chip's operating frequency is high, the CPU may not be able to keep up with the speed of logic transitions. To prevent such situations, the 1st and 2nd bytes must be transferred at 1/16 of the desired baud rate; then the boot program calculates 16 times that as the desired baud rate.
When the serial operation mode is determined as I/O Interface mode, the SIO0 is configured for SCLK Input mode. Beginning with the third byte, the controller must ensure that its AC timing restrictions are satisfied at the selected baud rate. In the case of I/O Interface mode, the boot program does not check the receive error flag; thus there is no such thing as error acknowledge (x8H).
- (6) The 2nd byte, transmitted from the target board to the controller, is an acknowledge response to the 1st byte. The boot program echoes back the first byte: 86H for UART mode and 30H for I/O Interface mode.
- UART mode
If the SIO0 can be programmed to the baud rate at which the 1st byte was transferred, the boot program programs the BR0CR and sends back 86H to the controller as an acknowledge. If the SIO0 is not programmable at that baud rate, the boot program simply aborts with no error indication.
Following the 1st byte, the controller should allow for a time-out period of five seconds. If it does not receive 86H within the allotted time-out period, the controller should give up the communication.
The boot program sets the RXE bit in the SC0MOD register to enable reception before loading the SIO transmit buffer with 86H.

- I/O Interface mode

The boot program programs the SC0MOD0 and SC0CR registers to configure the SIO0 in I/O Interface mode (clocked by the rising edge of SCLK0), writes 30H to the SC0BUF. Then, the SIO0 waits for the SCLK0 signal to come from the controller. Following the transmission of the 1st byte, the controller should send the SCLK clock to the target board after a certain idle time (several microseconds). This must be done at 1/16 the desired baud rate. If the 2nd byte, which is from the target board to the controller, is 30H, then the controller should take it as a go-ahead. The controller must then deliver the 3rd byte to the target board at a rate equal to the desired baud rate. The boot program sets the RXE bit in the SC0MOD register to enable reception before loading the SIO transmit buffer with 30H.

-
- (7) The 3rd byte, which the target board receives from the controller, is a command. The code for the RAM Transfer command is 10H.

-
- (8) The 4th byte, transmitted from the target board to the controller, is an acknowledge response to the 3rd byte. Before sending back the acknowledge response, the boot program checks for a receive error. If there was a receive error, the boot program transmits x8H and returns to the state in which it waits for a command again. In this case, the upper four bits of the acknowledge response are undefined — they hold the same values as the upper four bits of the previously issued command. When the SIO0 is configured for I/O Interface mode, the boot program does not check for a receive error.

If the 3rd byte is equal to any of the command codes listed in Table 3.2, the boot program echoes it back to the controller. When the RAM Transfer command was received, the boot program echoes back a value of 10H and then branches to the RAM Transfer routine. Once this branch is taken, a password check is done. Password checking is detailed in Section 3.3.11.

If the 3rd byte is not a valid command, the boot program sends back x1H to the controller and returns to the state in which it waits for a command again. In this case, the upper four bits of the acknowledge response are undefined — they hold the same values as the upper four bits of the previously issued command.

-
- (9) The 5th to 16th bytes, which the target board receives from the controller, are a 12-byte password. The 5th byte is compared to the contents of address 0x0000_03F4 in the flash memory; the 6th byte is compared to the contents of address 0x0000_03F5 in the flash memory; likewise, the 16th byte is compared to the contents of address 0x0000_03FF in the flash memory. If the password checking fails, the RAM Transfer routine sets the password error flag.

-
- (10) The 17th byte is a checksum value for the password sequence (5th to 16th bytes). To calculate the checksum value for the 12-byte password, add the 12 bytes together, drop the carries and take the two's complement of the total sum. Transmit this checksum value from the controller to the target board. The checksum calculation is described in details in Section 3.3.13.

- (11) The 18th byte, transmitted from the target board to the controller, is an acknowledge response to the 5th to 17th bytes.

First, the RAM Transfer routine checks for a receive error in the 5th to 17th bytes. If there was a receive error, the boot program sends back 18H and returns to the state in which it waits for a command (i.e., the 3rd byte) again. In this case, the upper four bits of the acknowledge response are the same as those of the previously issued command (i.e., all 1s). When the SIO0 is configured for I/O Interface mode, the RAM Transfer routine does not check for a receive error.

Next, the RAM Transfer routine performs the checksum operation to ensure data integrity. Adding the series of the 5th to 17th bytes must result in zero (with the carry dropped). If it is not zero, one or more bytes of data has been corrupted. In case of a checksum error, the RAM Transfer routine sends back 11H to the controller and returns to the state in which it waits for a command (i.e., the 3rd byte) again.

Finally, the RAM Transfer routine examines the result of the password check. The following two cases are treated as a password error. In these cases, the RAM Transfer routine sends back 11H to the controller and returns to the state in which it waits for a command (i.e., the 3rd byte) again.

- Irrespective of the result of the password comparison, all of the 12 bytes of a password in the flash memory are the same value other than FFH.
- Not all of the password bytes transmitted from the controller matched those contained in the flash memory.

When all the above checks have been successful, the RAM Transfer routine returns a normal acknowledge response (10H) to the controller.

- (12) The 19th to 22nd bytes, which the target board receives from the controller, indicate the start address of the RAM region where subsequent data (e.g., a flash programming routine) should be stored. The 19th byte corresponds to bits 31–24 of the address, and the 22nd byte corresponds to bits 7–0 of the address.

- (13) The 23rd and 24th bytes, which the target board receives from the controller, indicate the number of bytes that will be transferred from the controller to be stored in the RAM. The 23rd byte corresponds to bits 15–8 of the number of bytes to be transferred, and the 24th byte corresponds to bits 7–0 of the number of bytes.

- (14) The 25th byte is a checksum value for the 19th to 24th bytes. To calculate the checksum value, add all these bytes together, drop the carries and take the two's complement of the total sum. Transmit this checksum value from the controller to the target board. The checksum calculation is described in details in Section 3.3.13.

- (15) The 26th byte, transmitted from the target board to the controller, is an acknowledge response to the 19th to 25th bytes of data. First, the RAM Transfer routine checks for a receive error in the 19th to 25th bytes. If there was a receive error, the RAM Transfer routine sends back 18H and returns to the state in which it waits for a command (i.e., the 3rd byte) again. In this case, the upper four bits of the acknowledge response are the same as those of the previously issued command (i.e., all 1s). When the SIO0 is configured for I/O Interface mode, the RAM Transfer routine does not check for a receive error.

Next, the RAM Transfer routine performs the checksum operation to ensure data integrity. Adding the series of the 19th to 25th bytes must result in zero (with the carry dropped). If it is not zero, one or more bytes of data has been corrupted. In case of a checksum error, the RAM Transfer routine sends back 11H to the controller and returns to the state in which it waits for a command (i.e., the 3rd byte) again.

- The RAM storage start address must be within the range 0xFFFFD_6000–0xFFFFD_EFFF.

When the above checks have been successful, the RAM Transfer routine returns a normal acknowledge response (10H) to the controller.

- (16) The 27th to mth bytes from the controller are stored in the on-chip RAM of the TMP19A43FDXBG. Storage begins at the address specified by the 19th–22nd bytes and continues for the number of bytes specified by the 23rd–24th bytes.
- (17) The (m+1)th byte is a checksum value. To calculate the checksum value, add the 27th to mth bytes together, drop the carries and take the two's complement of the total sum. Transmit this checksum value from the controller to the target board. The checksum calculation is described in details in Section 3.3.13.
- (18) The (m+2)th byte is a acknowledge response to the 27th to (m+1)th bytes.
First, the RAM Transfer routine checks for a receive error in the 27th to (m+1)th bytes. If there was a receive error, the RAM Transfer routine sends back 18H and returns to the state in which it waits for a command (i.e., the 3rd byte) again. In this case, the upper four bits of the acknowledge response are the same as those of the previously issued command (i.e., all 1s). When the SIO0 is configured for I/O Interface mode, the RAM Transfer routine does not check for a receive error.
- (19) Next, the RAM Transfer routine performs the checksum operation to ensure data integrity. Adding the series of the 27th to (m+1)th bytes must result in zero (with the carry dropped). If it is not zero, one or more bytes of data has been corrupted. In case of a checksum error, the RAM Transfer routine sends back 11H to the controller and returns to the state in which it waits for a command (i.e., the 3rd byte) again. When the above checks have been successful, the RAM Transfer routine returns a normal acknowledge response (10H) to the controller. If the (m+2)th byte was a normal acknowledge response, a branch is made to the address specified by the 19th to 22nd bytes in 32-bit ISA mode.

3.3.7 Show Flash Memory Sum Command

See Table 3.4.

- (20) The processing of the 1st and 2nd bytes are the same as for the RAM Transfer command.
- (21) The 3rd byte, which the target board receives from the controller, is a command. The code for the Show Flash Memory Sum command is 20H.
- (22) The 4th byte, transmitted from the target board to the controller, is an acknowledge response to the 3rd byte. Before sending back the acknowledge response, the boot program checks for a receive error. If there was a receive error, the boot program transmits x8H and returns to the state in which it waits for a command again. In this case, the upper four bits of the acknowledge response are undefined — they hold the same values as the upper four bits of the previously issued command. When the SIO0 is configured for I/O Interface mode, the boot program does not check for a receive error.
If the 3rd byte is equal to any of the command codes listed in Table 3.2 on page 3-18, the boot program echoes it back to the controller. When the Show Flash Memory Sum command was received, the boot program echoes back a value of 20H and then branches to the Show Flash Memory Sum routine.

If the 3rd byte is not a valid command, the boot program sends back x1H to the controller and returns to the state in which it waits for a command again. In this case, the upper four bits of the acknowledge response are undefined — they hold the same values as the upper four bits of the previously issued command.

- (23) The Show Flash Memory Sum routine adds all the bytes of the flash memory together. The 5th and 6th bytes, transmitted from the target board to the controller, indicate the upper and lower bytes of this total sum, respectively. For details on sum calculation, see Section 3.3.12.
- (24) The 7th byte is a checksum value for the 5th and 6th bytes. To calculate the checksum value, add the 5th and 6th bytes together, drop the carry and take the two's complement of the sum. Transmit this checksum value from the controller to the target board.
- (25) The 8th byte is the next command code.

3.3.8 Show Product Information Command

See Table 3.5.

- (26) The processing of the 1st and 2nd bytes are the same as for the RAM Transfer command.
- (27) The 3rd byte, which the target board receives from the controller, is a command. The code for the Show Product Information command is 30H.
- (28) The 4th byte, transmitted from the target board to the controller, is an acknowledge response to the 3rd byte. Before sending back the acknowledge response, the boot program checks for a receive error. If there was a receive error, the boot program transmits x8H and returns to the state in which it waits for a command again. In this case, the upper four bits of the acknowledge response are undefined — they hold the same values as the upper four bits of the previously issued command. When the SIO0 is configured for I/O Interface mode, the boot program does not check for a receive error.

If the 3rd byte is equal to any of the command codes listed in Table 3.2 on page 3-18, the boot program echoes it back to the controller. When the Show Flash Memory Sum command was received, the boot program echoes back a value of 30H and then branches to the Show Flash Memory Sum routine.

If the 3rd byte is not a valid command, the boot program sends back x1H to the controller and returns to the state in which it waits for a command again. In this case, the upper four bits of the acknowledge response are undefined — they hold the same values as the upper four bits of the previously issued command.
- (29) The 5th to 8th bytes, transmitted from the target board to the controller, are the data read from addresses 0x0000_03F0–0x0000_03F3 in the flash memory. Software version management is possible by storing a software id in these locations.
- (30) The 9th to 20th bytes, transmitted from the target board to the controller, indicate the product name, which is “TX19A43FD_ _ _” in ASCII code (where _ is a space).

- (31) The 21st to 24th bytes, transmitted from the target board to the controller, indicate the start address of the flash memory area containing the password, i.e., F4H, 03H, 00H, 00H.
- (32) The 25th to 28th bytes, transmitted from the target board to the controller, indicate the start address of the on-chip RAM, i.e., 00H, 60H, FDH, FFH.
- (33) The 29th to 32nd bytes, transmitted from the target board to the controller, are dummy data (FFH, 6FH, FDH, FFH).
- (34) The 33rd to 36th bytes, transmitted from the target board to the controller, indicate the end address of the on-chip RAM, i.e., FFH, FFH, FDH, FFH.
- (35) The 37th to 40th bytes, transmitted from the target board to the controller, are 00H, 70H, FDH and FFH.
The 41st to 44th bytes, transmitted from the target board to the controller, are FFH, EFH, FDH and FFH.
- (36) The 45th and 46th bytes, transmitted from the target board to the controller, indicate the presence or absence of the security and protect bits and whether the flash memory is divided into blocks. Bit 0 indicates the presence or absence of the security bit; it is 0 if the security bit is available. Bit 1 indicates the presence or absence of the protect bits; it is 0 if the protect bits are available. If bit 2 is 0, it indicates that the flash memory is divided into blocks. The remaining bits are undefined. The 45th and 46th bytes are 01H, 00H.
- (37) The 47th to 50th bytes, transmitted from the target board to the controller, indicate the start address of the on-chip flash memory, i.e., 00H, 00H, 00H, 00H.
- (38) The 51st to 54th bytes, transmitted from the target board to the controller, indicate the end address of the on-chip flash memory, i.e., FFH, FFH, 0FH, 00H.
- (39) The 55th to 56th bytes, transmitted from the target board to the controller, indicate the number of flash blocks available, i.e., 08H, 00H.
- (40) The 57th to 92nd bytes, transmitted from the target board to the controller, contain information about the flash blocks.
Flash blocks of the same size are treated as a group. Information about the flash blocks indicate the start address of a group, the size of the blocks in that group (in halfwords) and the number of the blocks in that group.
The 57th to 65th bytes are the information about the 128-kbyte blocks (Block 0 to Block 7). See Table 3.5 for the values of bytes transmitted.
- (41) The 66th byte, transmitted from the target board to the controller, is a checksum value for the 5th to 65th bytes. The checksum value is calculated by adding all these bytes together, dropping the carry and taking the two's complement of the total sum.
- (42) The 67th byte is the next command code.

3.3.9 Acknowledge Responses

The boot program represents processing states with specific codes. Table 3.6 to Table 3.8 show the values of possible acknowledge responses to the received data. The upper four bits of the acknowledge response are equal to those of the command being executed. Bit 3 of the code indicates a receive error. Bit 0 indicates an invalid command error, a checksum error or a password error. Bit 1 and bit 2 are always 0. Receive error checking is not done in I/O Interface mode.

Table 3.6 ACK Response to the Serial Operation Mode Byte

Return Value	Meaning
86H	The SIO can be configured to operate in UART mode. (See Note)
30H	The SIO can be configured to operate in I/O Interface mode.

Note: If the serial operation mode is determined as UART, the boot program checks if the SIO can be programmed to the baud rate at which the operation mode byte was transferred. If that baud rate is not possible, the boot program aborts, without sending back any response.

Table 3.7 ACK Response to the Command Byte

Return Value	Meaning
x8H (See Note)	A receive error occurred while getting a command code.
x1H (See Note)	An undefined command code was received. (Reception was completed normally.)
10H	The RAM Transfer command was received.
20H	The Show Flash Memory Sum command was received.
30H	The Show Product Information command was received.

Note: The upper four bits of the ACK response are the same as those of the previous command code.

Table 3.8 ACK Response to the Checksum Byte

Return Value	Meaning
18H	A receive error occurred.
11H	A checksum or password error occurred.
10H	The checksum was correct.

3.3.10 Determination of a Serial Operation Mode

The first byte from the controller determines the serial operation mode. To use UART mode for communications between the controller and the target board, the controller must first send a value of 86H at a desired baud rate to the target board. To use I/O Interface mode, the controller must send a value of 30H at 1/16 the desired baud rate. Figure 3.2 shows the waveforms for the first byte.

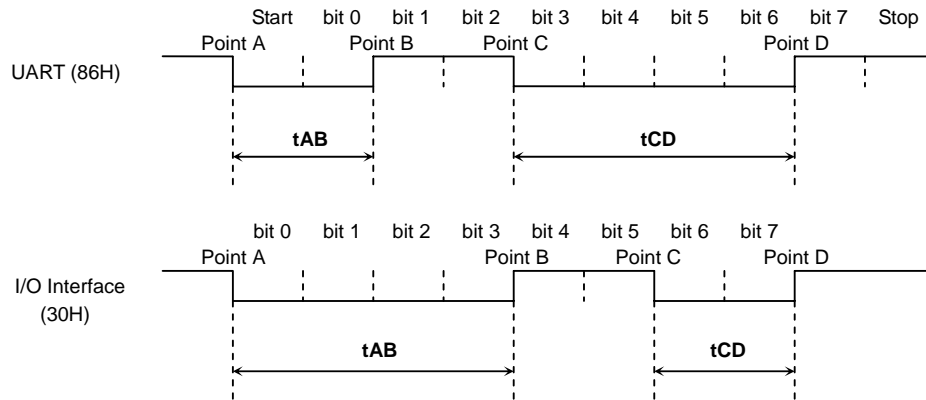

Figure 3.2 Serial Operation Mode Byte

After $\overline{\text{RESET}}$ is released, the boot program monitors the first serial byte from the controller, with the SIO reception disabled, and calculates the intervals of t_{AB} , t_{AC} and t_{AD} . Figure 3.3 shows a flowchart describing the steps to determine the intervals of t_{AB} , t_{AC} and t_{AD} . As shown in the flowchart, the boot program captures timer counts each time a logic transition occurs in the first serial byte. Consequently, the calculated t_{AB} , t_{AC} and t_{AD} intervals are bound to have slight errors. If the transfer goes at a high baud rate, the CPU might not be able to keep up with the speed of logic transitions at the serial receive pin. In particular, I/O Interface mode is more prone to this problem since its baud rate is generally much higher than that for UART mode. To avoid such a situation, the controller should send the first serial byte at 1/16 the desired baud rate.

The flowchart in Figure 3.4 shows how the boot program distinguishes between UART and I/O Interface modes. If the length of t_{AB} is equal to or less than the length of t_{CD} , the serial operation mode is determined as UART mode. If the length of t_{AB} is greater than the length of t_{CD} , the serial operation mode is determined as I/O Interface mode. Bear in mind that if the baud rate is too high or the timer operating frequency is too low, the timer resolution will be coarse, relative to the intervals between logic transitions. This becomes a problem due to inherent errors caused by the way in which timer counts are captured by software; consequently the boot program might not be able to determine the serial operation mode correctly.

For example, the serial operation mode may be determined to be I/O Interface mode when the intended mode is UART mode. To avoid such a situation, when UART mode is utilized, the controller should allow for a time-out period within which it expects to receive an echo-back (86H) from the target board. The controller should give up the communication if it fails to get that echo-back within the allotted time. When I/O Interface mode is utilized, once the first serial byte has been transmitted, the controller should send the SCLK clock after a certain idle time to get an acknowledge response. If the received acknowledge response is not 30H, the controller should give up further communications.

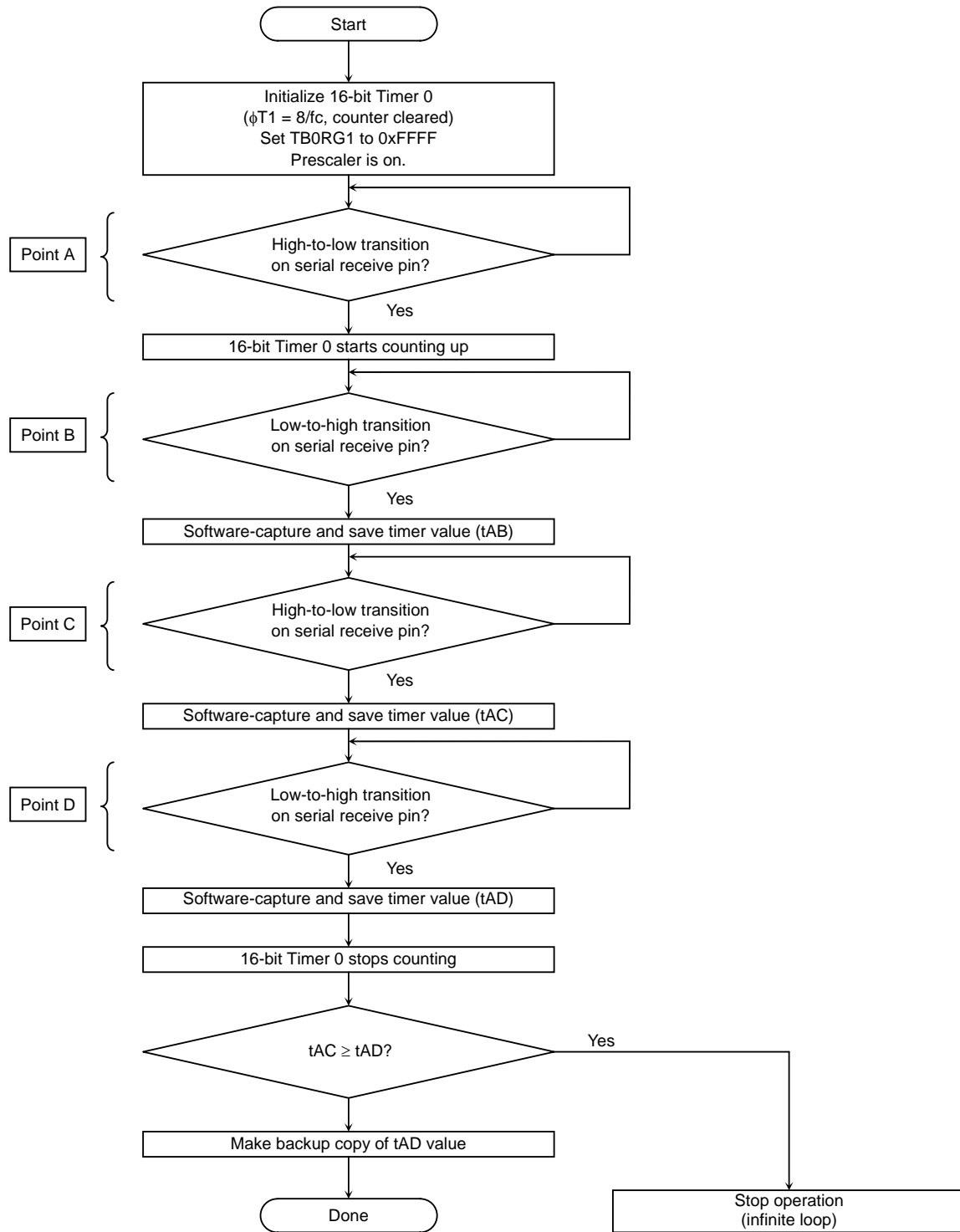

Figure 3.3 Serial Operation Mode Byte Reception Flow

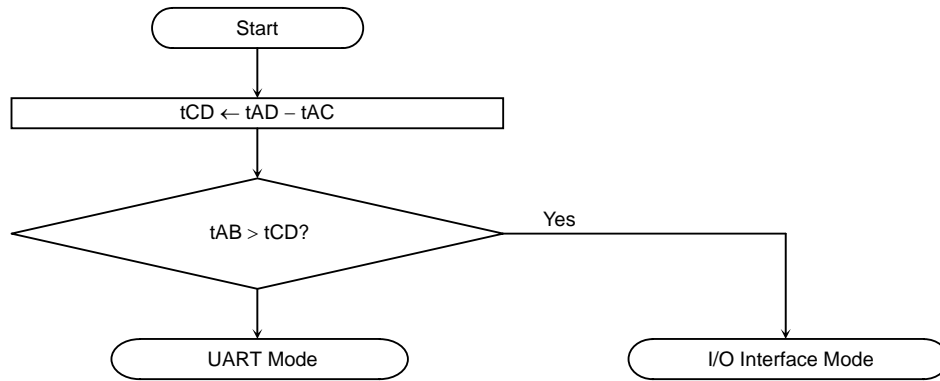

Figure 3.4 Serial Operation Mode Determination Flow

3.3.11 Password

The RAM Transfer command (10H) causes the boot program to perform a password check. Following an echo-back of the command code, the boot program checks the contents of the 12-byte password area (0x4000_0474 to 0x4000_047F) within the flash memory. If all these address locations contain the same bytes of data other than FFH, a password area error occurs. In this case, the boot program returns an error acknowledge (11H) in response to the checksum byte (the 17th byte), regardless of whether the password sequence sent from the controller is all FFHs.

The password sequence received from the controller (5th to 16th bytes) is compared to the password stored in the flash memory. Table 3.9 shows how they are compared byte-by-byte. All of the 12 bytes must match to pass the password check. Otherwise, a password error occurs, which causes the boot program to return an error acknowledge in response to the checksum byte (the 17th byte).

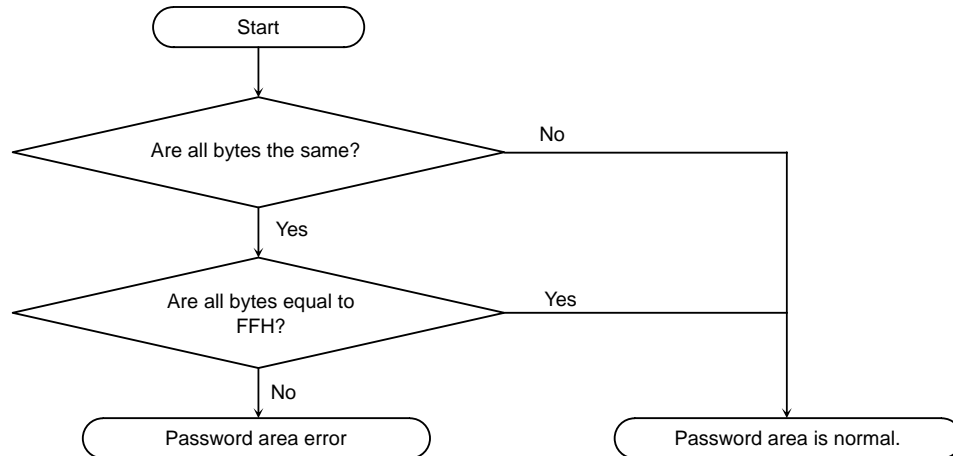

Figure 3.5 Password Area Check Flow

Table 3.9 Relationship between Received Bytes and Flash Memory Locations

Received Byte	Compared Flash Memory Data	ROM Protect
5th byte	Address 0x0000_0474	Address 0x0000_0004
6th byte	Address 0x0000_0475	Address 0x0000_0005
7th byte	Address 0x0000_0476	Address 0x0000_0006
8th byte	Address 0x0000_0477	Address 0x0000_0007
9th byte	Address 0x0000_0478	Address 0x0000_0008
10th byte	Address 0x0000_0479	Address 0x0000_0009
11th byte	Address 0x0000_047A	Address 0x0000_000A
12th byte	Address 0x0000_047B	Address 0x0000_000B
13th byte	Address 0x0000_047C	Address 0x0000_000C
14th byte	Address 0x0000_047D	Address 0x0000_000D
15th byte	Address 0x0000_047E	Address 0x0000_000E
16th byte	Address 0x0000_047F	Address 0x0000_000F

3.3.12 Calculation of the Show Flash Memory Sum Command

The Show Flash Memory Sum command adds all 512 kbytes of the flash memory together and provides the total sum as a halfword quantity. The sum is sent to the controller, with the upper eight bits first, followed by the lower eight bits.

Example:

A1H
B2H
C3H
D4H

For the interest of simplicity, assume the depth of the flash memory is four locations. Then the sum of the four bytes is calculated as:

$$A1H + B2H + C3H + D4H = 02EAH$$

Hence, 02H is first sent to the controller, followed by EAH.

3.3.13 Checksum Calculation

The checksum byte for a series of bytes of data is calculated by adding the bytes together, dropping the carries, and taking the two's complement of the total sum. The Show Flash Memory Sum command and the Show Product Information command perform the checksum calculation. The controller must perform the same checksum operation in transmitting checksum bytes.

Example:

Assume the Show Flash Memory Sum command provides the upper and lower bytes of the sum as E5H and F6H. To calculate the checksum for a series of E5H and F6H:

(43) Add the bytes together.

$$E5H + F6H = 1DBH$$

(44) Drop the carry.

(45) Take the two's complement of the sum, and that is the checksum byte.

$$0 - DBH = 25H$$

3.3.14 General Boot Program Flowchart

Figure 3.6 shows an overall flowchart of the boot program.

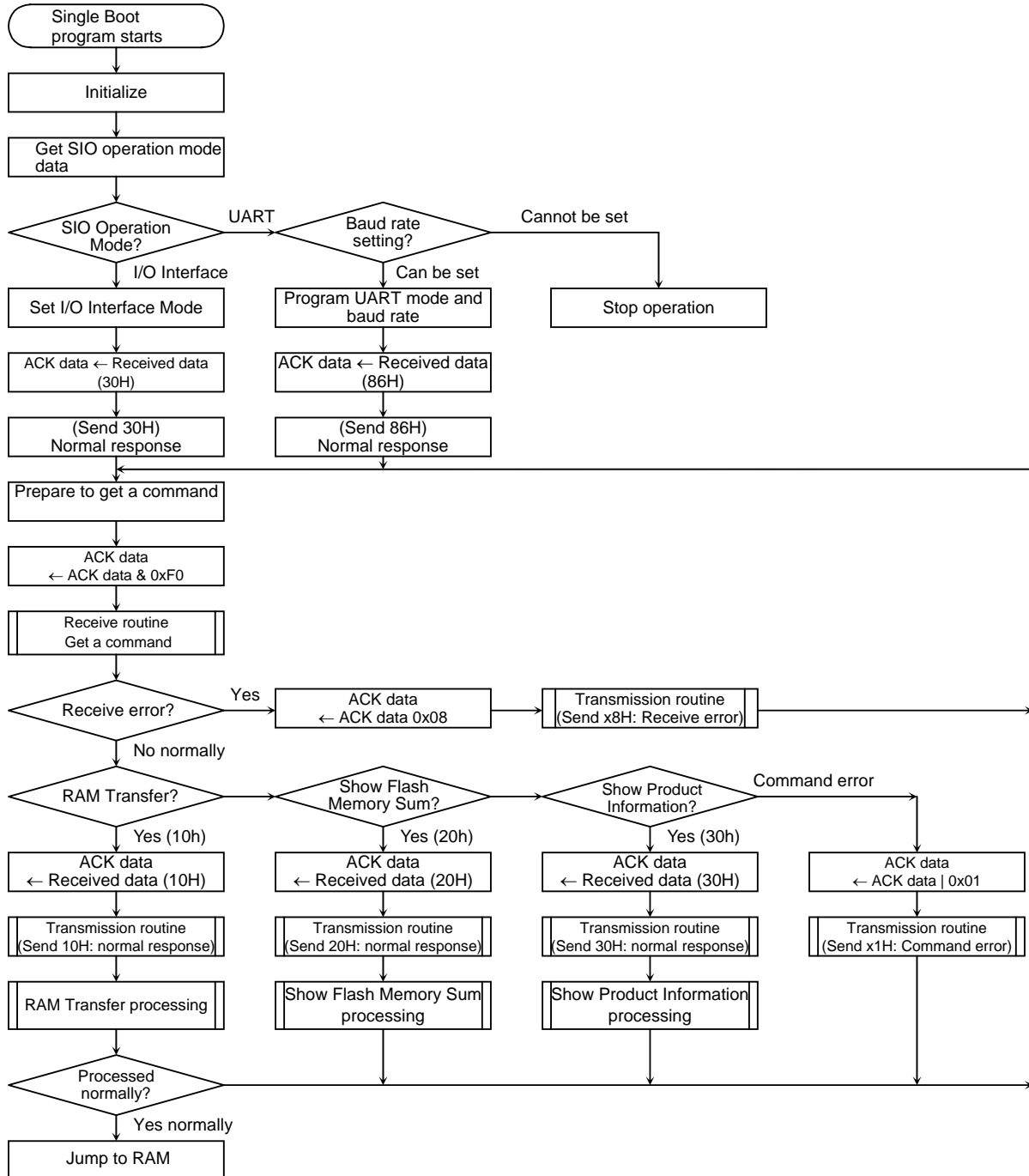

Figure 3.6 Overall Boot Program Flow

3.4 On-board Programming of Flash Memory (Rewrite/Erase)

In on-board programming, the CPU is to execute software commands for rewriting or erasing the flash memory. The rewrite/erase control program should be prepared by the user beforehand. Because the flash memory content cannot be read while it is being written or erased, it is necessary to run the rewrite/erase program from the internal RAM or from an external memory device after shifting to the user boot mode. In this section, flash memory addresses are represented in virtual addresses unless otherwise noted.

3.4.1 Flash Memory

Except for some functions, writing and erasing flash memory data are in accordance with the standard JEDEC commands. In writing or erasing, use the SW command of the CPU to enter commands to the flash memory. Once the command is entered, the actual write or erase operation is automatically performed internally.

Table 3-5 Flash Memory Functions

Major functions	Description
Automatic page program	Writes data automatically.
Automatic chip erase	Erases the entire area of the flash memory automatically.
Automatic block erase	Erases a selected block automatically. (128 kB at a time)
Write protect	The write or erase function can be individually inhibited for each block (of 128 kB). When all blocks are set for protection, the entire protection function is automatically enabled.
Protect function	By writing a 4-bit protection code, the write or erase function can be individually inhibited for each block.

Note that addressing of operation commands is different from the case of standard commands due to the specific interface arrangements with the CPU as detailed operation of the user boot mode and RAM transfer mode is described later. Also note that the flash memory is written in 32-bit blocks. So, 32-bit (word) data transfer commands must be used in writing the flash memory.

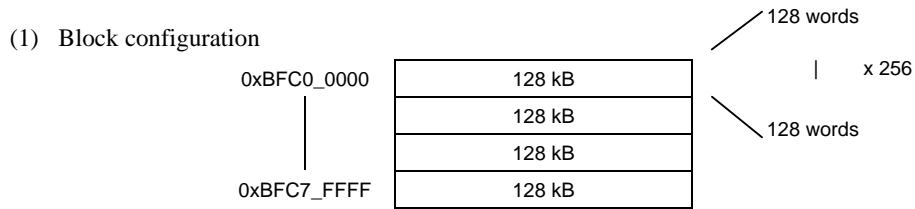

Fig. 3-4 Block Configuration of Flash Memory

(2) Basic operation

Generally speaking, this flash memory device has the following two operation modes:

- The mode to read memory data (Read mode)
- The mode to automatically erase or rewrite memory data (Automatic operation)

Transition to the automatic mode is made by executing a command sequence while it is in the memory read mode. In the automatic operation mode, flash memory data cannot be read and any commands stored in the flash memory cannot be executed. In the automatic operation mode, any interrupt or exception generation cannot set the device to the read mode except when a hardware reset is generated. During automatic operation, be sure not to cause any exceptions other than debug exceptions and reset while a DSU probe is connected. Any interrupt or exception generation cannot set the device to the read mode except when a hardware reset is generated.

1) Read

When data is to be read, the flash memory must be set to the read mode. The flash memory will be set to the read mode immediately after power is applied, when CPU reset is removed, or when an automatic operation is normally terminated. In order to return to the read mode from other modes or after an automatic operation has been abnormally terminated, either the Read/reset command (a software command to be described later) or a hardware reset is used. The device must also be in the read mode when any command written on the flash memory is to be executed.

- **Read/reset command and Read command (software reset)**

When an automatic operation is abnormally terminated, the flash memory cannot return to the read mode by itself (When $FLCS < RDY/BSY > = 0$, data read from the flash memory is undefined.) In this case, the Read/reset command can be used to return the flash memory to the read mode. Also, when a command that has not been completely written has to be canceled, the Read/reset command must be used to return to the read mode. The Read command is used to return to the read mode after executing the SW command to write the data "0x0000_00F0" to an arbitrary address of the flash memory.

- **With the Read/reset command, the device is returned to the read mode after completing the third bus write cycle.**

2) Command write

This flash memory uses the command control method. Commands are executed by executing a command sequence to the flash memory. The flash memory executes automatic operation commands according to the address and data combinations applied (refer to Command Sequence).

If it is desired to cancel a command write operation already in progress or when any incorrect command sequence has been entered, the Read/reset command is to be executed. Then, the flash memory will terminate the command execution and return to the read mode.

While commands are generally comprised of several bus cycles, the operation to apply the SW command to the flash memory is called "bus write cycle." The bus write cycles are to be in a specific sequential order and the flash memory will perform an automatic operation when the sequence of the bus write cycle data and address of a command write operation is in accordance with a predefined specific sequence. If any bus write cycle does not follow a predefined command write sequence, the flash memory will terminate the command execution and return to the read mode. The address [31:21] in each bus write cycle should be the virtual address [31:21] of command execution. It will be explained later for the address bits [20:8].

- (Note 1) Command sequences are executed from outside the flash memory area.
- (Note 2) The interval between bus write cycles for this device must be 15 system clock cycles or longer. The command sequencer in the flash memory device requires a certain time period to recognize a bus write cycle. If more than one bus write cycles are executed within this time period, normal operation cannot be expected. For adjusting the applicable bus write cycle interval using a software timer to be operated at the operating frequency, use the section 10 "ID-Read" to check for the appropriateness.
- (Note 3) Between the bus write cycles, never use any load command (such as LW, LH, or LB) to the flash memory or perform a DMA transmission by specifying the flash area as the source address. Also, don't execute a Jump command to the flash memory. While a command sequence is being executed, don't generate any interrupt such as maskable interrupts (except debug exceptions when a DSU probe is connected).
- If such an operation is made, it can result in an unexpected read access to the flash memory and the command sequencer may not be able to correctly recognize the command. While it could cause an abnormal termination of the command sequence, it is also possible that the written command is incorrectly recognized.
- (Note 4) The SYNC command must be executed immediately after the SW command for each bus write cycle.
- (Note 5) For the command sequencer to recognize a command, the device must be in the read mode prior to executing the command. Be sure to check before the first bus write cycle that the FLCS[0] RDY/BSY bit is set to "1." It is recommended to subsequently execute a Read command.
- (Note 6) Upon issuing a command, if any address or data is incorrectly written, be sure to perform a system reset operation or issue a reset command to return to the read mode again.

3) Reset

Hardware reset

The flash memory has a reset input as the memory block and it is connected to the CPU reset signal. Therefore, when the RESET input pin of this device is set to V_{IL} or when the CPU is reset due to any overflow of the watch dog timer, the flash memory will return to the read mode terminating any automatic operation that may be in progress. The CPU reset is also used in returning to the read mode when an automatic operation is abnormally terminated or when any mode set by a command is to be canceled. It should also be noted that applying a hardware reset during an automatic operation can result in incorrect rewriting of data. In such a case, be sure to perform the rewriting again.

Refer to Section 24.2.1 "Reset Operation" for CPU reset operations. After a given reset input, the CPU will read the reset vector data from the flash memory and starts operation after the reset is removed.

4) Automatic Page Programming

Writing to a flash memory device is to make "1" data cells to "0" data cells. Any "0" data cell cannot be changed to a "1" data cell. For making "0" data cells to "1" data cells, it is necessary to perform an erase operation.

The automatic page programming function of this device writes data in 128 word blocks. A 128 word block is defined by a same [31:9] address and it starts from the address [8:0] = 0 and ends at the address [8:0] = 0x1FF. This programming unit is hereafter referred to as a "page."

Writing to data cells is automatically performed by an internal sequencer and no external control by the CPU is required. The state of automatic page programming (whether it is in writing operation or not) can be checked by the FLCS [0] <RDY/BSY> register.

Also, any new command sequence is not accepted while it is in the automatic page programming mode. If it is desired to interrupt the automatic page programming, use the hardware reset function. If the operation is stopped by a hardware reset operation, it is necessary to once erase the page and then perform the automatic page programming again because writing to the page has not been normally terminated.

The automatic page programming operation is allowed only once for a page already erased. No programming can be performed twice or more times irrespective of the data cell value whether it is "1" or "0." Note that rewriting to a page that has been once written requires execution of the automatic block erase or automatic chip erase command before executing the automatic page programming command again. Note that an attempt to rewrite a page two or more times without erasing the content can cause damages to the device.

No automatic verify operation is performed internally to the device. So, be sure to read the data programmed to confirm that it has been correctly written.

The automatic page programming operation starts when the fourth bus write cycle of the command cycle is completed. On and after the fifth bus write cycle, data will be written sequentially starting from the next address of the address specified in the fourth bus write cycle (in the fourth bus write cycle, the page top address will be command written) (32 bits of data is input at a time). Be sure to use the SW command in writing commands on and after the fourth bus cycle. In this, any SW command shall not be placed across word boundary. On and after the fifth bus write cycle, data is command written to the same page area. Even if it is desired to write the page only partially, it is required to perform the automatic page programming for the entire page. In this case, the address input for the fourth bus write cycle shall be set to the top address of the page. Be sure to perform command write operation with the input data set to "1" for the data cells not to be set to "0." For example, if the top address of a page is not to be written, set the input data of the fourth bus write cycle to 0xFFFFFFFF to command write the data.

Once the fourth bus cycle is executed, it is in the automatic programming operation. This condition can be checked by monitoring the register bit FLCS [0] <RDY/BSY> (See Table 24.6). Any new command sequence is not accepted while it is in automatic page programming mode. If it is desired to stop operation, use the hardware reset function. Be careful in doing so because data cannot be written normally if the operation is interrupted. When a single page has been command written normally terminating the automatic page writing process, the FLCS [0] <RDY/BSY> bit is set to "1" and it returns to the read mode.

When multiple pages are to be written, it is necessary to execute the page programming command for each page because the number of pages to be written by a single execution of the automatic page program command is limited to only one page. It is not allowed for automatic page programming to process input data across pages.

Data cannot be written to a protected block. When automatic programming is finished, it automatically returns to the read mode. This condition can be checked by monitoring FLCS [0] <RDY/BSY> (See Table 24.6). If automatic programming has failed, the flash memory is locked in the mode and will not return to the read mode. For returning to the read mode, it is necessary to use the reset command or hardware reset to reset the flash memory or the device. In this case, while writing to the address has failed, it is recommended not to use the device or not to use the block that includes the failed address.

Note: Software reset becomes ineffective in bus write cycles on and after the fourth bus write cycle of the automatic page programming command.

5) Automatic chip erase

The automatic chip erase operation starts when the sixth bus write cycle of the command cycle is completed.

This condition can be checked by monitoring FLCS [0] <RDY/BSY> (See Table 24.6). While no automatic verify operation is performed internally to the device, be sure to read the data to confirm that data has been correctly erased. Any new command sequence is not accepted while it is in an automatic chip erase operation. If it is desired to stop operation, use the hardware reset function. If the operation is forced to stop, it is necessary to perform the automatic chip erase operation again because the data erasing operation has not been normally terminated.

Also, any protected blocks cannot be erased. If all the blocks are protected, the automatic chip erase operation will not be performed and it returns to the read mode after completing the sixth bus read cycle of the command sequence. When an automatic chip erase operation is normally terminated, it automatically returns to the read mode. If an automatic chip erase operation has failed, the flash memory is locked in the mode and will not return to the read mode.

For returning to the read mode, it is necessary to use the reset command or hardware reset to reset the flash memory or the device. In this case, the failed block cannot be detected. It is recommended not to use the device anymore or to identify the failed block by using the block erase function for not to use the identified block anymore.

6) Automatic block erase (128 kB at a time)

The automatic block erase operation starts when the sixth bus write cycle of the command cycle is completed.

This status of the automatic block erase operation can be checked by monitoring FLCS [0] <RDY/BSY> (See Table 24.6). While no automatic verify operation is performed internally to the device, be sure to read the data to confirm that data has been correctly erased. Any new command sequence is not accepted while it is in an automatic block erase operation. If it is desired to stop operation, use the hardware reset function. In this case, it is necessary to perform the automatic block erase operation again because the data erasing operation has not been normally terminated.

Also, any protected blocks cannot be erased. If an automatic block erase operation has failed, the flash memory is locked in the mode and will not return to the read mode. In this case, use the reset command or hardware reset to reset the flash memory or the device.

7) Automatic programming of protection bits

This device is implemented with four protection bits. The protection bits can be individually set in the automatic programming. The applicable protection bit is specified in the seventh bus write cycle. By automatically programming the protection bits, write and/or erase functions can be inhibited (for protection) individually for each block. The protection status of each block can be checked by the FLCS <BLPRO 3:0> register to be described later. This status of the automatic programming operation to set protection bits can be checked by monitoring FLCS <RDY/BSY> (See Table 24.6). Any new command sequence is not accepted while automatic programming is in progress to program the protection bits. If it is desired to stop the programming operation, use the hardware reset function. In this case, it is necessary to perform the programming operation again

because the protection bits may not have been correctly programmed. If all the protection bits have been programmed, the flash memory cannot be read from any area outside the flash memory such as the internal RAM. In this condition, the FLCS <BLPRO 3:0> bits are set to "0 x F" indicating that it is in the protected state (See Table 24.6). After this, no command writing can be performed.

Note: Software reset is ineffective in the seventh bus write cycle of the automatic protection bit programming command. The FLCS <RDY/BSY> bit turns to "0" after entering the seventh bus write cycle.

8) Automatic erasing of protection bits

Different results will be obtained when the automatic protection bit erase command is executed depending on the status of the protection bits. It depends on the status of FLCS <BLPRO 3:0> before the command execution whether it is set to "0 x F" or to any other values. Be sure to check the value of FLCS <BLPRO 3:0> before executing the automatic protection bit erase command.

- **When FLCS <BLPRO 3:0> is set to "0 x F" (all the protection bits are programmed):**

When the automatic protection bit erase command is command written, the flash memory is automatically initialized within the device. When the seventh bus write cycle is completed, the entire area of the flash memory data cells is erased and then the protection bits are erased. This operation can be checked by monitoring FLCS <RDY/BSY>. If the automatic operation to erase protection bits is normally terminated, FLCS will be set to "0x01." While no automatic verify operation is performed internally to the device, be sure to read the data to confirm that it has been correctly erased. For returning to the read mode while the automatic operation after the seventh bus cycle is in progress, it is necessary to use the hardware reset to reset the flash memory or the device. If this is done, it is necessary to check the status of protection bits by FLCS <BLPRO 3:0> after retuning to the read mode and perform either the automatic protection bit erase, automatic chip erase, or automatic block erase operation, as appropriate.

- **When FLCS <BLPRO 3:0> is other than "0 x F" (not all the protection bits are programmed):**

The protection condition can be canceled by the automatic protection bit erase operation. With this device, protection bits can be erased handling two bits at a time. The target bits are specified in the seventh bus write cycle and when the command is completed, the device is in a condition the two bits are erased. The protection status of each block can be checked by FLCS <BLPRO 3:0> to be described later. This status of the programming operation for automatic protection bits can be checked by monitoring FLCS <RDY/BSY>. When the automatic operation to erase protection bits is normally terminated, the two protection bits of FLCS <BLPRO 3:0> selected for erasure are set to "0."

In any case, any new command sequence is not accepted while it is in an automatic operation to erase protection bits. If it is desired to stop the operation, use the hardware reset function. When the automatic operation to erase protection bits is normally terminated, it returns to the read mode.

The FLCS <RDY/BSY> bit is "0" while in automatic operation and it turns to "1" when the automatic operation is terminated.

9) Flash control/ status register

This register is used to monitor the status of the flash memory and to indicate the block protection status.

Table 3-6 Flash Control Register

	7	6	5	4	3	2	1	0
Bit Symbol	BLPRO3	BLPRO2	BLPRO1	BLPRO0		ROMTYPE		RDY/BSY
Read/Write	R				R	R	R	R
After reset	0	0	0	0	0	0	0	1
Function	Protection area setting (for each 128 kB) 0000: No blocks are protected xxx1: Block 0 is protected xx1x: Block 1 is protected x1xx: Block 2 is protected 1xxx: Block 3 is protected				Always reads "0."	ROM ID bit 0: Flash 1: MROM	Always reads "0."	Ready/Busy 0: In operation 1: Operation terminated
	15	14	13	12	11	10	9	8
Bit Symbol								
Read/Write	R							
After reset	0	0	0	0	0	0	0	0
Function								
	23	22	21	20	19	18	17	16
Bit Symbol								
Read/Write	R							
After reset	0	0	0	0	0	0	0	0
Function								
	31	30	29	28	27	26	25	24
Bit Symbol								
Read/Write	R							
After reset	0	0	0	0	0	0	0	0
Function								

Fig. 3-5

Bit 0: Ready/Busy flag bit

The RDY/BSY output is provided as a means to monitor the status of automatic operation. This bit is a function bit for the CPU to monitor the function. When the flash memory is in automatic operation, it outputs "0" to indicate that it is busy. When the automatic operation is terminated, it returns to the ready state and outputs "1" to accept the next command. If the automatic operation has failed, this bit maintains the "0" output. By applying a hardware reset, it returns to "1."

(note)Please issue it after confirming the command issue is always a ready state.

A normal command not only is sent when the command is issued to a busy inside but also there is a possibility that the command after that cannot be input. In that case, please return by system reset or the reset command.

Bit 2: ROM type identification bit

This bit is read after reset to identify whether the ROM is a flash ROM or a mask ROM.

Flash ROM: "0"

Mask ROM: "1"

Bits [7:4]: Protection status bits (can be set to any combination of blocks)

Each of the protection bits (4 bits) represents the protection status of the corresponding block. When a bit is set to "1," it indicates that the block corresponding to the bit is protected. When the block is protected, data cannot be written to it.

10) ID-Read

Using the ID-Read command, you can obtain the type and other information on the flash memory contained in the device. The data to be loaded will be different depending on the address [15:14] of the fourth and subsequent bus write cycles (any input data other than 0xF can be used). On and after the fourth bus write cycle, when an LW command (to read an arbitrary flash memory area) is executed after an SW command, the ID value will be loaded (execute a SYNC command immediately after the LW command). Once the fourth bus write cycle of an ID-Read command has passed, the device will not automatically return to the read mode. In this condition, the set of the fourth bus write cycle and LW/SYNC commands can be repetitively executed. For returning to the read mode, reset the system or use the Read or Read/reset command.

The ID-Read command can be used when it is necessary for an application to identify whether the device in the product has an internal flash memory or an internal ROM. This is effective because a mask ROM doesn't have a command sequencer so it interprets any ID-Read command written as simply a pair of SW and LW commands applied to the mask ROM. If an ID-Read command is to be executed on a device with an internal mask ROM, it is necessary to select an address at which the rt value to a normal LW command is different from the ID-Read execution result (ID) from a device with an internal flash memory, also taking into account any applicable protection conditions.

(Important) The "interval between bus write cycles" between successive command sequences must be 15 system clock cycles or longer irrespective of the operating frequency used. This device doesn't have any function to automatically adjust the interval between bus write cycles regarding execution of multiple SW commands to the flash memory. Therefore, if an inadequate interval is used between two sets of bus write cycles, the flash memory cannot be written as expected. Prior to setting the device to work in the onboard programming mode, adjust the bus write cycle interval using a software timer, etc., to verify that the ID-Read command can be successfully executed at the operating frequency of the application program. In the onboard programming mode, use the bus write cycle interval at which the ID-Read command can be operated normally to execute command sequences to rewrite the flash memory.

(4) List of Command Sequences

Table 3-7 Flash Memory Access from the Internal CPU

Command sequence	First bus cycle	Second bus cycle	Third bus cycle	Fourth bus cycle	Fifth bus cycle	Sixth bus cycle	Seventh bus cycle
	Addr.	Addr.	Addr.	Addr.	Addr.	Addr.	Addr.
	Data	Data	Data	Data	Data	Data	Data
Read	0xXX	RA					
	0xF0	RD					
Read/reset	0x55XX	0xAAXX	0x55XX	RA			
	0xAA	0x55	0xF0	RD			
ID-Read	0x55XX	0xAAXX	0x55XX	IA	0xXX	–	
	0xAA	0x55	0x90	0x00	ID	–	
Automatic page programming (note)	0x55XX	0xAAXX	0x55XX	PA	PA	PA	PA
	0xAA	0x55	0xA0	PD0	PD1	PD2	PD3
Automatic chip erase	0x55XX	0xAAXX	0x55XX	0x55XX	0xAAXX	0x55XX	–
	0xAA	0x55	0x80	0xAA	0x55	0x10	–
Auto Block erase (note)	0x55XX	0xAAXX	0x55XX	0x55XX	0xAAXX	BA	–
	0xAA	0x55	0x80	0xAA	0x55	0x30	–
Protection bit programming	0x55XX	0xAAXX	0x55XX	0x55XX	0xAAXX	0x55XX	PBA
	0xAA	0x55	0x9A	0xAA	0x55	0x9A	0x9A
Protection bit erase	0x55XX	0xAAXX	0x55XX	0x55XX	0xAAXX	0x55XX	PBA
	0xAA	0x55	0x6A	0xAA	0x55	0x6A	0x6A

Fig. 3-6

(5) Supplementary explanation

- RA: Read address
- **RD: Read data**
- IA: ID address
- **ID: ID data**
- PA: Program page address
- PD: Program data (32-bit data)

After the fourth bus cycle, enter data in the order of the address for a page.

- BA: Block address
- PBA: Protection bit address

(Note 1)	Always set "0" to the address bits [1:0] in the entire bus cycle. (Setting values to bits [7:2] are undefined.)
(Note 2)	Bus cycles are "bus write cycles" except for the second bus cycle of the Read command, the fourth bus cycle of the Read/reset command, and the fifth bus cycle of the ID-Read command. Bus write cycles are executed by SW commands. Use "Data" in the table for the rt register [7:0] of SW commands. The address [31:16] in each bus write cycle should be the target flash memory address [31:16] of the command sequence. Use "Addr." in the table for the address [15:0].
(Note 3)	In executing the bus write cycles, the interval between each bus write cycle shall be 15 system clocks or more.
(Note 4)	The "Sync command" must be executed immediately after completing each bus write cycle.
(Note 5)	Execute the "Sync command" immediately following the "LW command" after the fourth bus write cycle of the ID-Read command.

(5) Address bit configuration for bus write cycles

Table 20.5.1.3 Address Bit Configuration for Bus Write Cycles

Address	Addr [31:21]	Addr [20]	Addr [19]	Addr [18:17]	Addr [16]	Addr [15]	Addr [14]	Addr [13]	Addr [12:9]	Addr [8]	Addr [7:0]
Normal commands	Normal bus write cycle address configuration										
	Flash area	"0" is recommended				Command					Addr [1:0]=0 (fixed), Others: 0 (recommended)
Block erase	BA: Block address (Set the sixth bus write cycle address for block erase operation)										
	Flash area	"0" is recommended	Block selection	Addr[1:0]=0 (fixed), Others: 0 (recommended)							
Auto page programming	PA: Program page address (Set the fourth bus write cycle address for page programming operation)										
	Flash area	"0" is recommended	Block selection	Page selection					Addr[1:0]=0 (fixed), Others: 0 (recommended)		
ID-READ	IA: ID address (Set the fourth bus write cycle address for ID-Read operation)										
	Flash area	"0" is recommended			ID address			Addr[1:0]=0 (fixed), Others: 0 (recommended)			
Protection bit programming	PBA: Protection bit address (Set the seventh bus write cycle address for protection bit programming)										
	Flash area	"0" is recommended			Protection bit write 00: Block 0 01: Block 1 10: Block 2 11: Block 3			Addr[1:0]=0 (fixed), Others: 0 (recommended)			
Protection bit erase	PBA: Protection bit address (Set the seventh bus write cycle address for protection bit erasure)										
	Flash area	"0" is recommended			Erase protection for 0: Blocks 0, 1 1: Blocks 2, 3			Addr[1:0]=0 (fixed), Others: 0 (recommended)			

(Note) Table 20.5.1.2 "Flash Memory Access from the Internal CPU" can also be used.

(Note) Address setting can be performed according to the "Normal bus write cycle address configuration" from the first bus cycle.

(Note) "'0" is recommended" can be changed as necessary.

Table 3-8 Block Erase Address Table

BA	Address Range		Size
	Flash Memory Address	When applied to the projected area	
Block 0	0xBFC0_0000-0xBFC1_FFFF	0x0000_0000-0x0001_FFFF	128 kB
Block 1	0xBFC2_0000-0xBFC3_FFFF	0x0002_0000-0x0003_FFFF	128 kB
Block 2	0xBFC4_0000-0xBFC5_FFFF	0x0004_0000-0x0005_FFFF	128 kB
Block 3	0xBFC6_0000-0xBFC7_FFFF	0x0006_0000-0x0007_FFFF	128 kB

Example: When BA0 is to be selected, any single address in the range 0xBFC0_0000 to 0xBFC1_FFFF may be entered.

Table 3-9 Protection Bit Programming Address Table

OPBA	The seventh bus write cycle address [15:14]	
	Address [15]	Address [14]
Block 0	0	0
Block 1	0	1
Block 2	1	0
Block 3	1	1

Table 3-10 Protection Bit Erase Address Table

OPBA	The seventh bus write cycle address [15:14]	
	Address [15]	Address [14]
Block 0	0	X
Block 1	0	X
Block 2	1	X
Block 3	1	X

The protection bit erase command will erase bits 0 and 1 together.

The bits 2 and 3 are also erased together.

Table 3-11 The ID-Read command's fourth bus write cycle ID address (IA) and the data to be read by the following LW command (ID)

IA [15:14]	ID [7: 0]	Code
00b	0x98	Manufacturer code
01b	0x5A	Device code
10b	Reserved	---
11b	0x05	Macro code

4. Various protecting functions

4.1 Overview

The ROM protect function for designating the internal ROM (flash) area as a read-protected area and the DSU protect function for prohibiting the use of DSU (DSU-Probe) are built into the TMP19A43. The read protect functions specifically include the following:

- Flash protect function
- ROM data protect function
- DSU protect function

4.2 Features

4.2.1 Flash Protect Function

<FLASH>

A built-in flash can prohibit the operation of writing and the deletion at every the block of every 128 Kbyte. This function is called the block protecting.

To make the block protecting function effective, it protects it corresponding to the block where it wants to put protecting.

The bit is made "1". The block protecting can be released by making the protecting bit "0". (Please see the chapter of the Flash operation explanation about the program method.)The protecting bit can be monitored by FLCS register < BLPRO3:0 > bit.

The state to put protecting on all blocks is called the FLASH protecting. It is necessary to note it because all the protecting bits become "0" after automatically deleting all data of the flash when the protecting release operates after it puts it into the state of the LASH protecting of 1°F(operation that makes the protecting bit "0").

<Mask>

FLASH is always being protected in the mask version, and the FLASH protecting cannot be released. This function doesn't influence usual operation in the mask version.

<FLASH/MASK>

It is necessary to be protecting FLASH to make "ROM data protecting" and "DSU protecting" that will explain in the future effective.

4.2.2 ROM data Protect

As for ROM data protecting, the execution of the command to the flash is prohibited in the function it, and the flash version that limits reading data to building FLASH/ROM into. When ROM protecting register ROMSEC1<RSECON > bit is "1", ROM data protecting becomes effective with FLASH protected.

If instructions in the ROM area have been replaced with instructions in the RAM area in a PC by using the ROM correction function, a PC shows the instructions as residing in the flash ROM area. Because they actually reside in the RAM area, data cannot be read in a ROM protected state. To read data by using instructions held in the overwritten RAM area, it is necessary to write data to RAM by using a program available in the ROM area or to use other means.

If the ROM area is put in a protected state, the following operations cannot be performed:

- Using instructions placed in areas other than the ROM area to load or store the data taken from the ROM area
- Store to DMAC register (NMI by the bus error is generated.)
- Loading or storing the data taken from the ROM area in accordance with EJTAG
- Using BOOT-ROM to load or store the data taken from the ROM area (FLASH only)
- Executing flash writer to load or store the data taken from the ROM area(FLASH only)
- Using instructions placed in areas other than the ROM area to access the registers (ROMSEC1, ROMSEC2) that concern the protection of the ROM area
- Executing the command to unprotect automatic blocking in writer mode, performing the flash command sequences other than the automatic blocking unprotect command sequence, and performing the flash command sequence in single or boot mode by specifying an address in the ROM area(FLASH only)

The following operations can be performed even if the ROM area is in a protected state:

- Using instructions placed in the ROM area to load the data taken from the ROM area
- Using instructions placed in all areas to load the data taken from areas other than the ROM area
- Using instructions placed in all areas to make instructions branch off to the ROM area
- Performing PC trace (there are restrictions) or break on the ROM area in accordance with EJTAG
- Data transfer of ROM area by DMAC

4.2.3 DSU Protect

The DSU protecting function is a function for invalidating the connection of DSU-probe to enable third parties other than the user to read the data of a built-in flash easily.

When SEQMOD register < DSUOFF > bit is "1", the DSU protecting becomes effective with FLASH protected.

In the DSUOFF bit, the flash version, the mask version, and the state of the first stage are "1". It enters the state of the DSU protecting as long as the FLASH protecting is always effective in the mask version, and the DSUOFF bit is not set to "0" by the user program.

It doesn't enter the state of the DSU protecting if protecting is not put on all blocks of FLASH in the flash version. An initial state enters the state of the DSU protecting as well as the mask version when FLASH is being protected putting protecting on all blocks of FLASH.

(note)

The DSUOFF bit can be accessed only with the instruction put on built-in ROM in the state of ROM data protecting. It is necessary to note it because it is necessary to put the program of the DSU protecting release on built-in ROM.

4.3 Protect Configuration and Protect Statuses

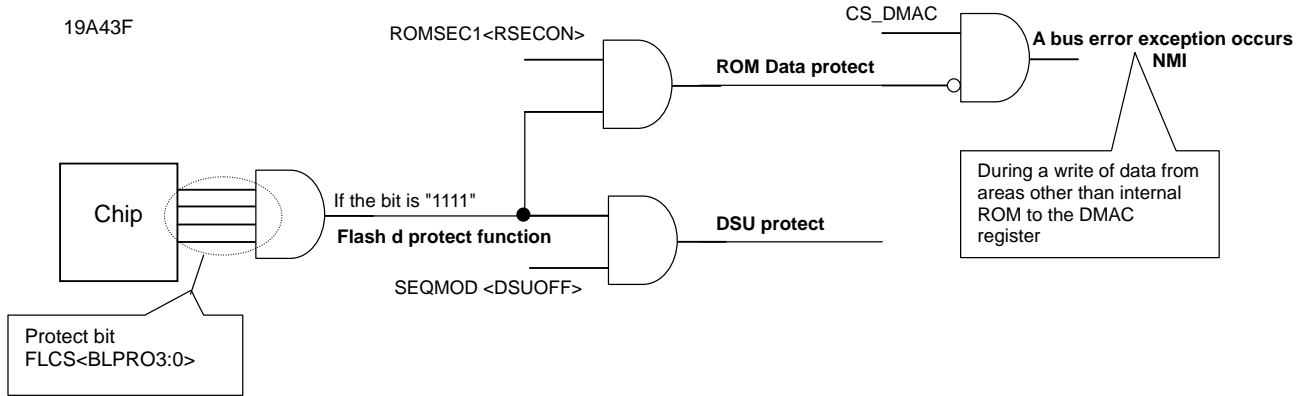

Fig. 4-1 Various Protect Statuses

Table 4-1 Protect Statuses in Each Mode

Protect bit setting FLCS<BLPRO 3:0>		1111				≠ 1111
ROM protect enable bit ROMSEC1<RSECON>		1		0		Don't Care
DSU protect enable bit SEQMOD <DSUOFF>		1	0	1	0	Don't Care
Flash read protect status		ON				OFF
ROM protect status		ON		OFF		OFF
DSU protect status		ON	OFF	ON	OFF	OFF
Single /single boot mode	Read of flash from internal ROM	○	○	○	○	○
	Read of flash from areas other than internal ROM	× *1	× *1	○	○	○
	Clearing of ROM protect enable status (from ROM)	○	○	/	/	○
	Clearing of ROM protect enable status (from areas other than ROM)	× *2	× *2	/	/	○
	Clearing of DSU protect enable status (from ROM)	○	/	○	/	○
	Clearing of DSU protect enable status (from areas other than ROM)	× *3	/	○	/	○
	Issuing of the command to erase protect bits	× *4	× *4	○ *8	○ *8	○
	Issuing of commands other than the command to erase protect bits	× *5	× *5	× *7	× *7	Δ *9
	Writing of data to the DMAC setting register (from ROM)	○	○	○	○	○
	Writing of data to the DMAC setting register (from areas other than ROM)	× *6	× *6	○	○	○

- *1 : The data of address "0xBFC0_0000" or "0xBFC0_0002" can be read.
- *2 : Stored data is masked. A write to registers cannot be executed (data in registers cannot be cleared).
- *3 : Stored data is masked. A write to registers cannot be executed (data in registers cannot be cleared).
- *4 : A command address is masked, and flash memory does not recognize commands.
- *5 : A command address is masked, and flash memory does not recognize commands.
- *6 : A bus error exception occurs (when making the DMAC register setting).
- *7 : Because a read of flash memory is prohibited, commands are not recognized.
- *8 : Because a read of flash memory is prohibited, issued commands are converted to the command for erasing the whole flash memory area and the command for erasing all protect bits.

4.4 Register

Flash control/status register

This register shows the status of flash memory being monitored and the block protect status of flash memory.

Table 4-2 Flash Control Register

FLCS (0xFFFF_E520)	Bit Symbol	7	6	5	4	3	2	1	0
	Read/Write	R				R	R	R	R
	After reset by power-on	0 (1)	0 (1)	0 (1)	0 (1)	0	0 (1)	0	1
	Function	Protect area setting (in units of 128 KB) 0000: All blocks unprotected xxx1: Block 0 protected xx1x: Block 1 protected x1xx: Block 2 protected 1xxx: Block 3 protected (MASK : "1111")				"0" is read.	ROM identification bit 0: Flash 1: MROM	"0" is read.	Ready/Busy 0: In auto operation 1: Auto operation completed (MASK:"1")
	Bit Symbol	15	14	13	12	11	10	9	8
	Read/Write	R							
	After reset by power-on	0	0	0	0	0	0	0	0
	Function								
	Bit Symbol	23	22	21	20	19	18	17	16
	Read/Write	R							
After reset by power-on	0	0	0	0	0	0	0	0	
Function									
Bit Symbol	31	30	29	28	27	26	25	24	
Read/Write	R								
After reset by power-on	0	0	0	0	0	0	0	0	
Function									

Bit 0: Ready/Busy flag bit

The RDY/BSY output is provided to identify the status of auto operation. This bit is a functional bit for monitoring this function by communicating with the CPU. If flash memory is in auto operation, "0" is output to show that flash memory is busy. As flash memory completes auto operation and goes into a ready state, "1" is output and the next command will be accepted. If the result of auto operation is faulty, this bit continues to output "0." It returns to "1" upon a hardware reset.

(Note) Before issuing a command, make sure that flash memory is in a ready state. If a command is issued when flash memory is busy, a right command cannot be generated and there is the possibility that subsequent commands may not be able to be input. In this case, you must return to a normal functional state by executing a system reset or issuing a reset command.

Bit 2: ROM type identification bit

This bit is used to identify the type of flash ROM or the type of mask ROM based on the value after a reset.

Flash ROM: "0"

Mask ROM: "1"

Bit [7:4]: Protect bit (x: A combination setting can be made for each block)

The protect bit (4-bit) value corresponds to the protect status of each block. If this bit is "1," the corresponding block is in a protected state. A protected block cannot be overwritten.

Table 4-3 ROM Protect Register

ROMSEC1 (0xFFFF_E518)		7	6	5	4	3	2	1	0	
	Bit Symbol									RSECON
	Read/Write	R								R/W
	After reset by power-on	0								1
Function	"0" is always read.								ROM protect 1: ON 0: OFF (see note)	
		15	14	13	12	11	10	9	8	
Bit Symbol										
Read/Write	R									
After reset by power-on	0									
Function	"0" is always read.									
		23	22	21	20	19	18	17	16	
Bit Symbol										
Read/Write	R									
After reset by power-on	0									
Function										
		31	30	29	28	27	26	25	24	
Bit Symbol										
Read/Write	R									
After reset by power-on	0									
Function	"0" is always read.									

(Note) This register is initialized only by power-on reset in the FLASH version.

The mask version is usually initialized at each reset.

(Note) To access this register, 32-bit access is required.

Table 4-4 ROM Protect Lock Register

	7	6	5	4	3	2	1	0
ROMSEC2 (0xFFFF_E51C)	Bit Symbol							
	Read/Write	W						
	After reset	Undefined						
	Function	See note.						
	15	14	13	12	11	10	9	8
Bit Symbol								
Read/Write	W							
After reset	Undefined							
Function	See note.							
	23	22	21	20	19	18	17	16
Bit Symbol								
Read/Write	W							
After reset	Undefined							
Function	See note.							
	31	30	29	28	27	26	25	24
Bit Symbol								
Read/Write	W							
After reset	Undefined							
Function	See note.							

- (Note)** If this register is set to "0x0000_003D" after ROMSEC1<RSECON> is set, appropriate bit values are automatically set in ROMSEC1<RSECON>.
- (Note)** If the ROM area is protected, the registers ROMSEC1 and ROMSEC2 can be accessed only by using the instructions residing in the ROM area.
- (Note)** To access this register, 32-bit access is required.
- (Note)** This register is a write-only register. If it is read, values will be undefined.

Table 4-5 DSU Protect Mode Register

SEQMOD (0xFFFF_E510)	Bit Symbol								DSUOFF
	Read/Write	R							R/W
	After reset	0							1
	Function	"0" is always read.							1: DSU disabled 0: DSU enabled
		7	6	5	4	3	2	1	0
	Bit Symbol								
	Read/Write	R							
	After reset	0							
	Function	"0" is always read.							
		15	14	13	12	11	10	9	8
	Bit Symbol								
	Read/Write	R							
	After reset	0							
	Function	"0" is always read.							
		23	22	21	20	19	18	17	16
	Bit Symbol								
	Read/Write	R							
	After reset	0							
	Function	"0" is always read.							
		31	30	29	28	27	26	25	24
	Bit Symbol								
	Read/Write	R							
	After reset	0							
	Function	"0" is always read.							

- (Note)** This register is initialized only by power-on reset in the FLASH version.
- (Note)** The mask version is usually initialized at each reset. To access this register, 32-bit access is required.

Table 4-6 DSU Protect Control Register

SEQCNT (0xFFFF_E514)	Bit Symbol	DSECODE07	DSECODE06	DSECODE05	DSECODE04	DSECODE03	DSECODE02	DSECODE01	DSECODE00
	Read/Write	W							
	After reset	0							
	Function	Write "0x0000_00C5."							
		15	14	13	12	11	10	9	8
	Bit Symbol	DSECODE15	DSECODE14	DSECODE13	DSECODE12	DSECODE11	DSECODE10	DSECODE09	DSECODE08
	Read/Write	W							
	After reset	0							
	Function	Write "0x0000_00C5."							
		23	22	21	20	19	18	17	16
	Bit Symbol	DSECODE23	DSECODE22	DSECODE21	DSECODE20	DSECODE19	DSECODE18	DSECODE17	DSECODE16
	Read/Write	W							
	After reset	0							
	Function	Write "0x0000_00C5."							
		31	30	29	28	27	26	25	24
	Bit Symbol	DSECODE31	DSECODE30	DSECODE29	DSECODE28	DSECODE27	DSECODE26	DSECODE25	DSECODE24
	Read/Write	W							
	After reset	0							
	Function	Write "0x0000_00C5."							

- (Note)** To access this register, 32-bit access is required.
- (Note)** This register is a write-only register. If it is read, values will be undefined.

4.5 Protected-related / Release Settings

If it is necessary to overwrite flash memory or protect bits in a protected state, "automatic protect bit deletion" must be executed or the ROM protect function must be disabled. DSU cannot be used if it is in a protected state.

Flash memory may go into a read-protected state after the automatic protect bit program is executed. In this case, it is necessary to set DSU-PROBE to "enable" before the automatic protect bit program is executed.

(The mask version is possible only the release of ROM security, and the protecting bit cannot be rewritten.)

If "automatic protect bit deletion" is executed when flash memory is in a read-protected state, flash memory is automatically initialized inside this device. Therefore, extra caution must be used when switching from one state to a read-protected state. (FLASH only)

4.5.1 Flash Protect Function

The flash protecting function cannot be released always effectively in the mask version.

It becomes effective by putting the block protecting on all of the four blocks in the flash version.

The flash memory command sequence and protect bit program commands are used to enable or disable the flash read protect function. For further information, refer to the command sequence explained in the chapter describing the operations of flash memory.

(notes concerning FLASH version)

The protecting bit is cleared after all the data of the flash is deleted when the protecting bit release command is executed with the flash protected, and the flash protecting is released.

In the state of ROM data protecting, explains as follows, the command execution to the flash is disregarded. It is necessary to release ROM data protecting first clearing the RSECON bit of ROM protecting register when the flash protecting is released with ROM protected.

4.5.2 ROM data Protect

ROM data protecting is effective the flash protecting and becomes effective at ROM protecting register ROMSEC1<RSECON>="1".

After releasing reset, the RSECON bit is initialized by "1". The flash protecting is sure to enter the state of ROM data protecting in the mask version after releasing reset because it is always effective.

It decides whether to enter the state of ROM data protecting by the state of the flash protecting in the flash version.

When ROM protecting register is rewritten with ROM data protected, rewriting can be executed only from the program put on built-in ROM. Therefore, it is necessary to prepare the release program of ROM data protecting on built-in ROM.

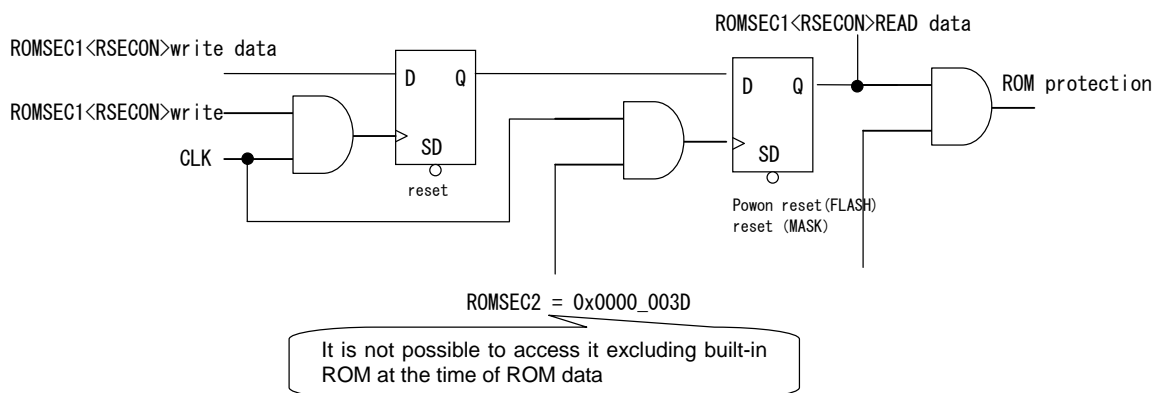

ROM data protecting is released by setting ROM protecting register ROMSEC1<RSECON>="0" when protecting is released, and writing protecting code "0x0000_003D" in ROM protecting lock register ROMSEC2. Moreover, ROM data protecting function can be set again by similarly setting ROM protecting register ROMSEC1<RSECON>="1" when ROM protecting is set, and writing protecting code "0x0000_003D" in ROM protecting lock register ROMSEC2.

It is necessary to note the ROMSEC2 register because the reading data is different from original write data because of the register only for writing.

The initialization of ROM protecting register is different in the flash version and the mask version.

It provides with the power-on reset circuit in the flash version, ROM protecting register is initialized by power-on reset, and the value doesn't usually change in reset.

It is usually initialized by reset in the mask version because power-on reset is not provided.

It is necessary to note it in the mask version because it is usually initialized at each reset.

4.5.3 DSU Protect

DSU data protecting is effective the flash protecting and becomes effective at DSU protecting register SEQMOD<RSECON>="1".

After releasing reset, the DSUOFF bit is initialized by "1". The flash protecting is sure to enter the state of DSU data protecting in the mask version after releasing reset because it is always effective.

It decides whether to enter the state of ROM data protecting by the state of the flash protecting in the flash version.

When DSU protecting register is rewritten with ROM data protected, rewriting can be executed only from the program put on built-in ROM. Therefore, it is necessary to prepare the release program of DSU data protecting on built-in ROM.

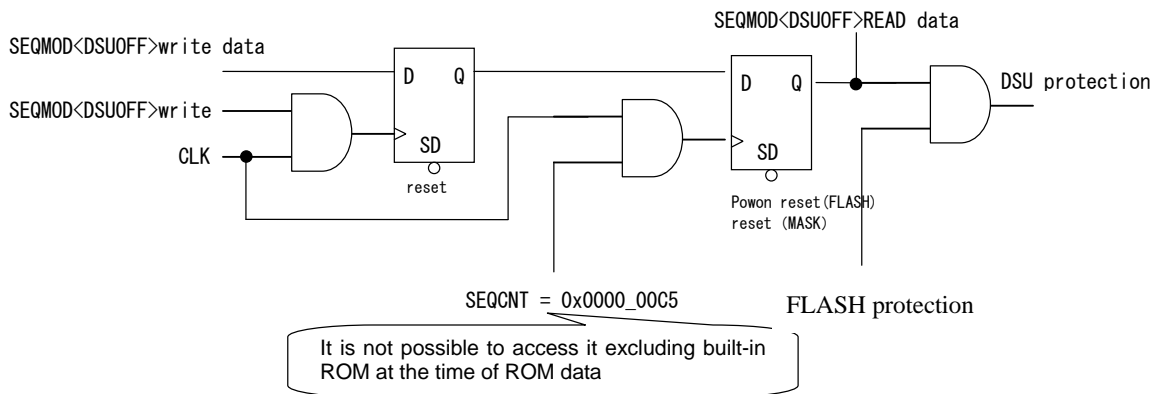

DSU protecting is released by setting DSU protecting register SEQMOD<DSUOFF>"0" when protecting is released, and writing protecting code "0x0000_00C5" in ROM protecting lock register SEQCNT. Moreover, DSU protecting function can be set again by similarly setting ROM protecting register SEQMOD<DSUOFF>"1" when DSU protecting is set, and writing protecting code "0x0000_00C5" in DSU protecting lock register SEQCNT.

It is necessary to note the SEQCNT register because the reading data is different from original write data because of the register only for writing.

The initialization of DSU protecting register is different in the flash version and the mask version.

It provides with the power-on reset circuit in the flash version, DSU protecting register is initialized by power-on reset, and the value doesn't usually change in reset.

It is usually initialized by reset in the mask version because power-on reset is not provided.

It is necessary to note it in the mask version because it is usually initialized at each reset.

4.5.4 ROM Protect Register: ROMSEC1<RSECON>

The ROM protect register is equipped with a power-on reset circuit. Caution must be exercised as data read from the ROMSEC1<RSECON> bit is different from the actually written data. How data is processed is shown below. The mask version is usually initialized by reset though FLASH goods are initialized by power-on reset.

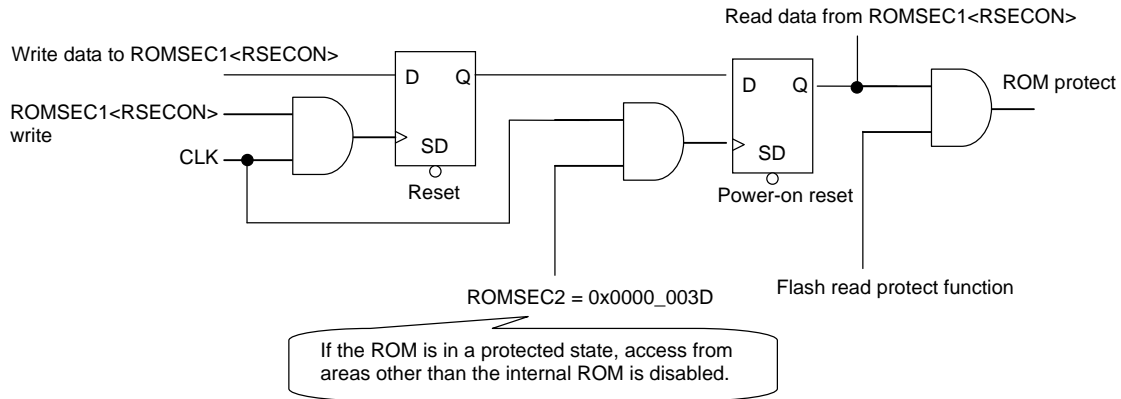

4.5.5 DSU Protect Mode Register: SEQMOD <DSUOFF>

The DSU protect mode register is equipped with a power-on reset circuit. Caution must be exercised as data read from the SEQMOD <DSUOFF> bit is different from the actually written data. How data is processed is shown below. The mask version is usually initialized by reset though FLASH goods are initialized by power-on reset.

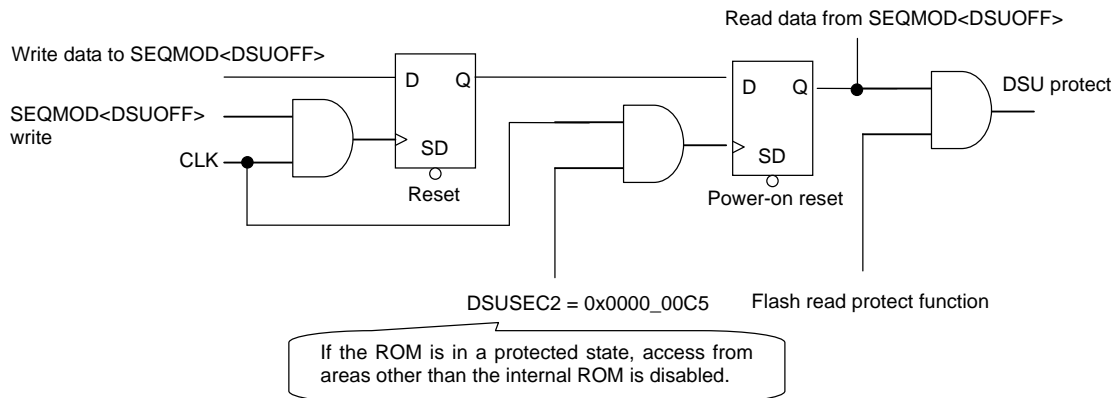

5. Electrical Characteristics

The letter x in equations presented in this chapter represents the cycle period of the fsys clock selected through the programming of the SYSCR1.SYSCK bit. The fsys clock may be derived from either the high-speed or low-speed crystal oscillator. The programming of the clock gear function also affects the fsys frequency. All relevant values in this chapter are calculated with the high-speed (fc) system clock (SYSCR1.SYSCK = 0) and a clock gear factor of 1/fc (SYSCR1.GEAR[2:0] = 000).

5.1 Absolute Maximum Ratings

Parameter		Symbol	Rating	Unit
Supply voltage		V _{CC15} (Core)	- 0.3to3.0	V
		V _{CC3} (I/O)	- 0.3to3.9	
		AV _{CC3} (A/D)	- 0.3to3.9	
		DA _{VCC} (D/A)	- 0.3to3.5	
		DV _{CC3}	- 0.3to3.9	
Supply voltage		V _{IN}	- 0.3toV _{CC} + 0.3	V
Low-level output current	Per pin	I _{OL}	5	mA
	Total	ΣI _{OL}	50	
High-level output current	Per pin	I _{OH}	-5	
	Total	ΣI _{OH}	50	
Power dissipation (Ta = 85° C)		PD	600	mW
Soldering temperature (10 s)		T _{SOLDER}	260	°C
Storage temperature		T _{STG}	-40to125	°C
Operating Temperature	Exceptduring Flash W/E	T _{OPR}	-20 to 85	°C
	During Flash W/E		0 to 70	
Write/erase cycles		N _{EW}	100	cycle

$$V_{CC15}=DV_{CC15}=CV_{CC15}=CV_{CCH}, V_{CC3}=DV_{CC3}=CV_{CCL},$$

$$V_{SS}=DV_{SS}=AV_{SS}=CV_{SS}=DAGND$$

Note: Absolute maximum ratings are limiting values of operating and environmental conditions which should not be exceeded under the worst possible conditions. The equipment manufacturer should design so that no Absolute maximum rating value is exceeded with respect to current, voltage, power dissipation, temperature, etc. Exposure to conditions beyond those listed above may cause permanent damage to the device or affect device reliability, which could increase potential risks of personal injury due to IC blowup and/or burning.

5.2 DC ELECTRICAL CHARACTERISTICS (1/3)

Ta = -20 to 85°C

Parameter		Symbol	Rating	Min.	Typ. (Note 1)	Max.	Unit
Supply voltage	AVCC3 = 3.3V CVCCCH = DVCC15 DVCC3 = CVCCCL	DVCC15 CVCCCH	fosc = 8to10MHz fs = 30kHzto34kHz fsys = 15kHzto34kHz 4MHzto40MHz	1.35		1.65	V
		DAVCC		2.3		2.7	
	DVCC3 CVCCCL	2.7			3.6		
Low-level input voltage	P7 to P8 (Used as a port)	V _{IL1}	$2.7V \leq AVCC3 \leq 3.6V$	-0.3		0.3 AVCC3	V
	Normal port	V _{IL2}	$2.7V \leq DVCC3 \leq 3.6V$			0.3 DVCC3	
	Schmitt-Triggered port	V _{IL3}	$2.7V \leq DVCC3 \leq 3.6V$			0.2 DVCC3	
	X1	V _{IL4}	$1.35V \leq CVCCCH \leq 1.65V$			0.1 CVCCCH	
	XT1	V _{IL5}	$2.7V \leq CVCCCL \leq 3.6V$			0.1 CVCCCL	

Note 1: Ta = 25°C, DVCC15=1.5V, DVCC3= AVCC3=3.3V, DVCC=2.5V, unless otherwise noted

Ta = -20 to 85°C

Parameter	Symbol	Rating	Min.	Typ. (Note 1)	Max.	Unit
High-level input voltage	P7 to P8 (Used as a port) Normal port	V_{IH1}	$2.7V \leq AVCC3 \leq 3.6V$	0.7 AVCC3	DVCC3 + 0.3 DVCC15+ 0.2 CVCCH+ 0.2 CVCCL+0.3	V
	Normal port	V_{IH2}	$2.7V \leq DVCC3 \leq 3.6V$	0.7 DVCC3		
	Schmitt-Triggered port	V_{IH3}	$2.7V \leq DVCC3 \leq 3.6V$	0.8 DVCC3		
	X1	V_{IH4}	$1.35V \leq CVCCH \leq 1.65V$	0.9 CVCCH		
	XT2	V_{IH4}	$2.7V \leq CVCCL \leq 3.6V$	0.9 CVCCL		
Low-level output voltage	V_{OL}	$I_{OL} = 2mA$	$DVCC3 \geq 2.7V$		0.4	V
High-level output voltage	V_{OH}	$I_{OH} = -2mA$	$DVCC3 \geq 2.7V$	2.4		

Note 1: Ta = 25°C, DVCC 15=1.5V, DVCC3= AVCC3=3.3V, DVCC=2.5V, unless otherwise noted

5.3 DC ELECTRICAL CHARACTERISTICS (2/3)

Ta = -20 to 85°C

Parameter	Symbol	Rating	Min.	Typ. (Note 1)	Max.	Unit
Input leakage current	I _{LI}	0.0 ≤ V _{IN} ≤ DVCC15 0.0 ≤ V _{IN} ≤ DVCC3 0.0 ≤ V _{IN} ≤ AVCC3 0.0 ≤ V _{IN} ≤ DAVCC		0.02	± 5	μA
Output leakage current	I _{LO}	0.2 ≤ V _{IN} ≤ DVCC15 - 0.2 0.2 ≤ V _{IN} ≤ DVCC3 - 0.2 0.2 ≤ V _{IN} ≤ AVCC3 - 0.2 0.2 ≤ V _{IN} ≤ DAVCC - 0.2		0.05	± 10	
Pull-up resistor at Reset	RRST	DVCC3 = 2.7V to 3.6V	20	50	150	kΩ
Schmitt-Triggered port	VTH	2.7V ≤ DVCC3 ≤ 3.6V	0.3	0.6		V
Programmable pull-up/ pull-down resistor	PKH	DVCC3 = 2.7V to 3.6V	20	50	150	kΩ
Pin capacitance (Except power supply pins)	C _{IO}	fc = 1MHz			10	pF

Note 1: Ta = 25°C, DVCC15 = 1.5V, DVCC3 = AVCC3 = 3.3V, DVCC = 2.5V, unless otherwise noted

5.4 DC ELECTRICAL CHARACTERISTICS (3/3)

DVCC15=CVCCH=1.35Vto1.65V, CVCCL= DVCC3=AVCC3=2.7Vto3.6V,
DAVCC=2.3Vto2.7V

Ta= -20 to 85°C

Parameter	Symbol	Rating	Min.	Typ. (Note 1)	Max.	Unit
NORMAL(Note 2): Gear = 1/1	I _{CC}	f _{sys} =40 MHz (f _{osc} = 10 MHz)		50	74	mA
IDLE(Doze) (Note 3)				20	29	
IDLE(Halt) (Note 3)				18	28	
SLOW (Note 4)		f _s = 32.768kHz		140	995	μA
SLEEP (Note 4)		f _s = 32.768kHz		30	985	μA
STOP					27	980

Note 1: Ta = 25°C, DVCC 15=1.5V,DVCC3= AVCC3=3.3V,DVCC=2.5V, unless otherwise noted

(note1) I_{CC} NORMAL:

Measured with the CPU dhrystone operating (DSU is excluded.), RAM, FLASH.

All functions operating. D/A and A/D excluded.

(note2) I_{CC} IDLE :

Measured with all functions stoping.

(note3) I_{CC} SLOW, SLEEP :

Measured with RTC on low-speed

I_{CC} : The current where flows is included.

(DVCC15、 DVCC3、 CVCCH、 CVCCL、 AVCC3、 DAVCC)

5.5 10-bit ADC Electrical Characteristics

DVCC15=CVCCH=1.35Vto1.65V, CVCCL= DVCC3=AVCC3=VREFH=2.7Vto3.6V,
 DAVCC=2.3Vto2.7V,AVSS = DVSS ,Ta= -20 to 85°C
 AVCC3 load capacitanc= 3.3μF, VREFH load capacitanc= 3.3μF

Parameter	Symbol	Rating	Min	Typ	Max	Unit
Analog reference voltage (+)	VREFH		2.7	3.3	3.6	V
Analog reference voltage (-)	VREFL		AVSS	AVSS	AVSS	V
Analog input voltage	VAIN		VREFL		VREFH	V
Analog supply current	A/D conversion	IREF	DVSS = AVSS = VREFL	4.5	5.5	mA
	Non-A/D conversion		DVSS = AVSS = VREFL	± 0.02	± 5	μA
supply current	A/D conversion	—	Non-IREF		3	mA
INL error	—	AIN resistance $\leq 600 \Omega$ AIN load capacitance $\leq 30\text{pF}$ Conversion time $\geq 1.15 \mu\text{s}$		± 2	± 3	LSB
DNL error				± 1	± 2	
Offset error				± 2	± 4	
Fullscale error				± 2	± 4	
INL error	—	AIN resistance $\leq 600 \Omega$ AIN load capacitance $\geq 0.1 \mu\text{F}$ Conversion time $\geq 1.15 \mu\text{s}$		± 2	± 3	
DNL error				± 1	± 2	
Offset error				± 2	± 4	
Fullscale error				± 2	± 4	
INL error	—	AIN resistance $\leq 1.3\text{k} \Omega$ AIN load capacitance $\geq 0.1 \mu\text{F}$ Conversion time $\geq 1.15 \mu\text{s}$		± 2	± 3	
DNL error				± 1	± 2	
Offset error				± 2	± 4	
Fullscale error				± 2	± 4	
INL error	—	AIN resistance $\leq 10\text{k} \Omega$ AIN load capacitance $\geq 0.1 \mu\text{F}$ Conversion time $\geq 2.30 \mu\text{s}$		± 2	± 3	
DNL error				± 1	± 2	
Offset error				± 2	± 4	
Fullscale error				± 2	± 4	

(Note 1) $1\text{LSB} = (\text{VREFH} - \text{VREFL}) / 1024[\text{V}]$

5.6 8bit D/A Electrical Characteristics

DVCC15=CVCCH=1.35V to 1.65V, CVCCL= DVCC3=AVCC3=2.7V to 3.6V,
DAVCC=2.3V to 2.7V

Parameter	Symbol	Rating	Min	Typ	Max	Unit
Analog reference voltage (+)	DAVREF		2.3	2.5	2.7	V
Analog supply current	IDREF			1	2	mA
				± 0.02	± 5	μA
supply current	Icc				5	mA
Output current	IDA0, IDA1		± 1			mA
Range of output voltage	DA0, DA1		DAGND+0.3		DAVCC-0.3	V
Fullscale error	—			± 2	± 3	LSB

(Note 1) $1\text{LSB} = (\text{DAVREF} - \text{DAGND}) / 256[\text{V}]$

(Note 2) IDREF current value is in the Dual channel operation .

(Note 3) No guarantee about Relative accuracy in the Dual channel operation

(Note 4) Load Maximum capacitance of each DAX pin is 100pF.

5.7 AC Electrical Characteristics

5.7.1 Multiplex Bus mode

- (1) DVCC15=CVCC15=1.35Vto1.65V, AVCC3= 2.7Vto3.6V
 DVCC3= 2.7Vto3.6V, DAVCC = 2.3Vto2.7V, Ta = -20to85°C

① ALE width = 1 clock cycle, 2 programmed wait state

No.	Parameter	Symbol	Equation		40 MHz (fsys)(Note)		Unit
			Min	Max	Min	Max	
1	System clock period (x)	t _{sys}	25				ns
2	A0-A15 VALID TO ALE LOW	t _{AL}	x - 11		14.0		ns
3	A0-A15 HOLD AFTER ALE LOW	t _{LA}	x - 8		17.0		ns
4	ALE pulse width high	t _{LL}	x - 6		19.0		ns
5	ALE low to \overline{RD} , \overline{WR} or \overline{HWR} asserted	t _{LC}	x - 8		17.0		ns
6	\overline{RD} , \overline{WR} or \overline{HWR} negated to ALE high	t _{CL}	x - 8		17.0		ns
7	A0-A15 valid to \overline{RD} , \overline{WR} or \overline{HWR} asserted	t _{ACL}	2x - 11		39.0		ns
8	A16-A23 valid to \overline{RD} , \overline{WR} or \overline{HWR} asserted	t _{ACH}	2x - 11		39.0		ns
9	A16-A23 hold after \overline{RD} , \overline{WR} or \overline{HWR} negated	t _{CAR}	x - 11		14.0		ns
10	A0-A15 valid to D0-D15 Data in	t _{ADL}		x (2 + TW+ALE) - 43		82.0	ns
11	A16-A23 valid to D0-D15 Data in	t _{ADH}		x (2 + TW+ALE) - 43		82.0	ns
12	\overline{RD} asserted to D0-D15 data in	t _{RD}		x (1 + TW) - 40		35.0	ns
13	\overline{RD} width low	t _{RR}	x (1 + TW) - 6		69		ns
14	D0-D15 hold after \overline{RD} negated	t _{HR}	0		0		ns
15	\overline{RD} negated to next A0-A15 output	t _{RAE}	x - 6		19.0		ns
16	$\overline{WR}/\overline{HWR}$ width low	t _{WW}	x (1 + TW) - 6		69.0		ns
17	D0-D15 valid to \overline{WR} or \overline{HWR} negated	t _{DW}	x (1 + TW) - 11		64.0		ns
18	D0-D15 hold after \overline{WR} or \overline{HWR} negated	t _{WD}	x - 11		14.0		ns
19	A16-A23 valid to \overline{WAIT} input	t _{AWH}		x + x (ALE) + x (TW - 1) - 32		43.0	ns
20	A0-A15 valid to \overline{WAIT} input	t _{AWL}		x + x (ALE) + x (TW - 1) - 32		43.0	ns
21	\overline{WAIT} hold after \overline{RD} , \overline{WR} or \overline{HWR} asserted	t _{CW}	x (TW - 3) - 16	x (TW - 1) - 29	9.0	46.0	ns

Note 1: No. 1 to 21:

Internal 2 wait insertion, ALE "1" Clock, @40MHz

$$TW = W + 2N$$

W : Number of Auto wait insertion, 2N : Number of external wait insertion

$$TW = 2 + 2 \times 1 = 4$$

AC measurement conditions:

Output levels: High = 0.8DVCC3 V/Low 0.2DVCC3 V, CL = 30 pF

Input levels: High = 0.7DVCC3 V/Low 0.3DVCC3 V

② ALE width = 1 clock cycles, 2 programmed wait state

No.	Parameter	Symbol	Equation		40 MHz (fsys)(Note)		Unit
			Min	Max	Min	Max	
1	System clock period (x)	t _{sys}	25				ns
2	A0-A15 VALID TO ALE LOW	t _{AL}	x - 11		14.0		ns
3	A0-A15 HOLD AFTER ALE LOW	t _{LA}	x - 8		17.0		ns
4	ALE pulse width high	t _{LL}	x - 6		19.0		ns
5	ALE low to \overline{RD} , \overline{WR} or \overline{HWR} asserted	t _{LC}	x - 8		17.0		ns
6	\overline{RD} , \overline{WR} or \overline{HWR} negated to ALE high	t _{CL}	x - 8		17.0		ns
7	A0-A15 valid to \overline{RD} , \overline{WR} or \overline{HWR} asserted	t _{ACL}	2x - 11		39.0		ns
8	A16-A23 valid to \overline{RD} , \overline{WR} or \overline{HWR} asserted	t _{ACH}	2x - 11		39.0		ns
9	A16-A23 hold after \overline{RD} , \overline{WR} or \overline{HWR} negated	t _{CAR}	x - 11		14.0		ns
10	A0-A15 valid to D0-D15 Data in	t _{ADL}		x (2 + TW+ALE) - 43		82.0	ns
11	A16-A23 valid to D0-D15 Data in	t _{ADH}		x (2 + TW+ALE) - 43		82.0	ns
12	\overline{RD} asserted to D0-D15 data in	t _{RD}		x (1 + TW) - 40		35.0	ns
13	\overline{RD} width low	t _{RR}	x (1 + TW) - 6		69		ns
14	D0-D15 hold after \overline{RD} negated	t _{HR}	0		0		ns
15	\overline{RD} negated to next A0-A15 output	t _{RAE}	x - 6		19.0		ns
16	$\overline{WR}/\overline{HWR}$ width low	t _{WW}	x (1 + TW) - 6		69.0		ns
17	D0-D15 valid to \overline{WR} or \overline{HWR} negated	t _{DW}	x (1 + TW) - 11		64.0		ns
18	D0-D15 hold after \overline{WR} or \overline{HWR} negated	t _{WD}	x - 11		14.0		ns
19	A16-A23 valid to \overline{WAIT} input	t _{AWH}		x + x (ALE) + x (TW - 1) - 32		43.0	ns
20	A0-A15 valid to \overline{WAIT} input	t _{AWL}		x + x (ALE) + x (TW - 1) - 32		43.0	ns
21	\overline{WAIT} hold after \overline{RD} , \overline{WR} or \overline{HWR} asserted	t _{CW}	x (TW - 3) - 16	x (TW - 1) - 29	9.0	46.0	ns

Note 1: No. 1 to 21:

Internal 2 wait insertion, ALE "1" Clock, @40MHz

$$TW = W + 2N$$

W : Number of Auto wait insertion, 2N : Number of external wait insertion

$$TW = 2 + 2 \times 1 = 4$$

AC measurement conditions:

Output levels: High = 0.8DVCC3 V/Low 0.2DVCC3 V, CL = 30 pF

Input levels: High = 0.7DVCC3 V/Low 0.3DVCC3 V

(1) Read cycle timing, ALE width = 1 clock cycle, 1 programmed wait state

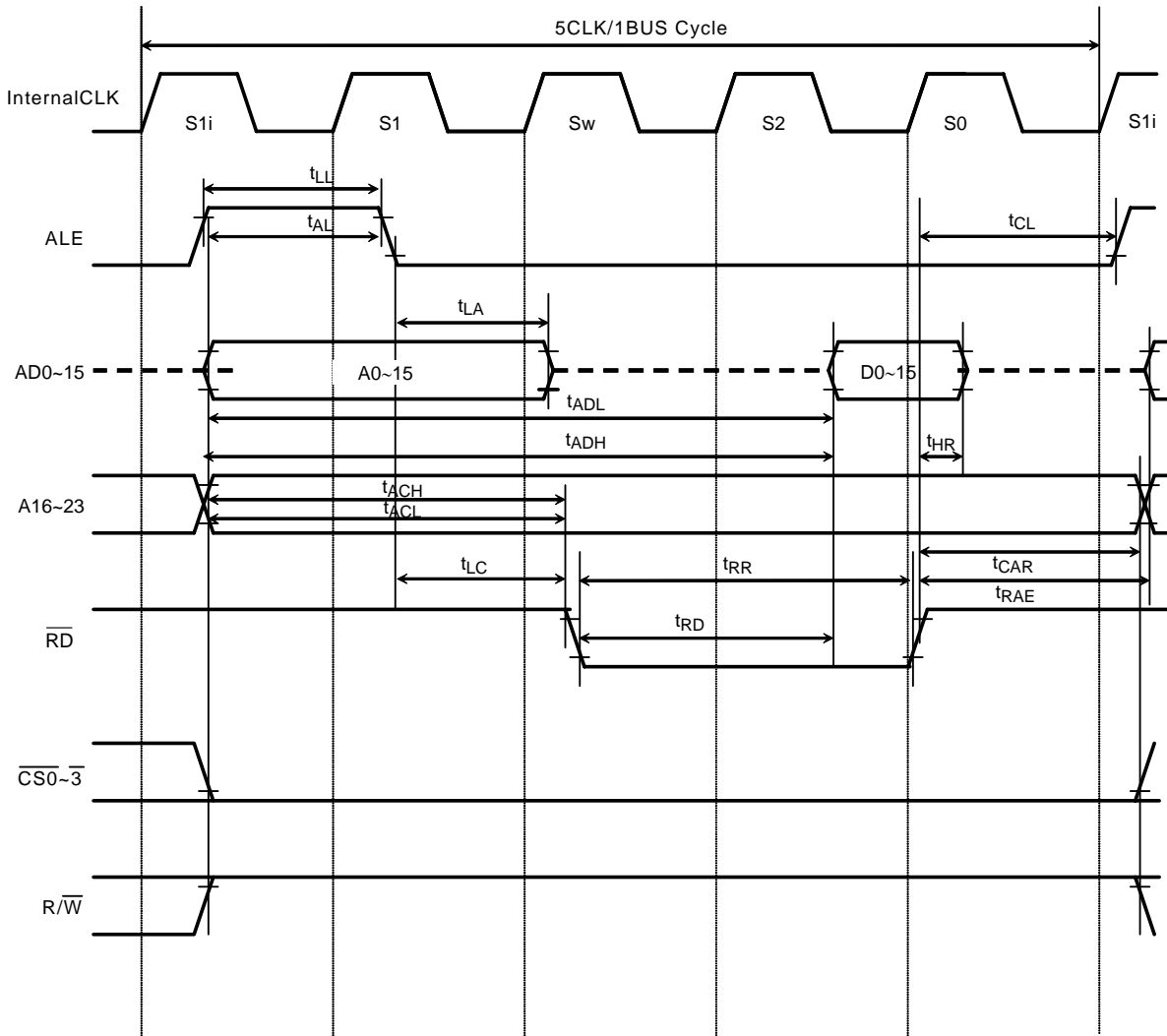

(2) Read cycle timing, ALE width = 1 clock cycle, 2 programmed wait state

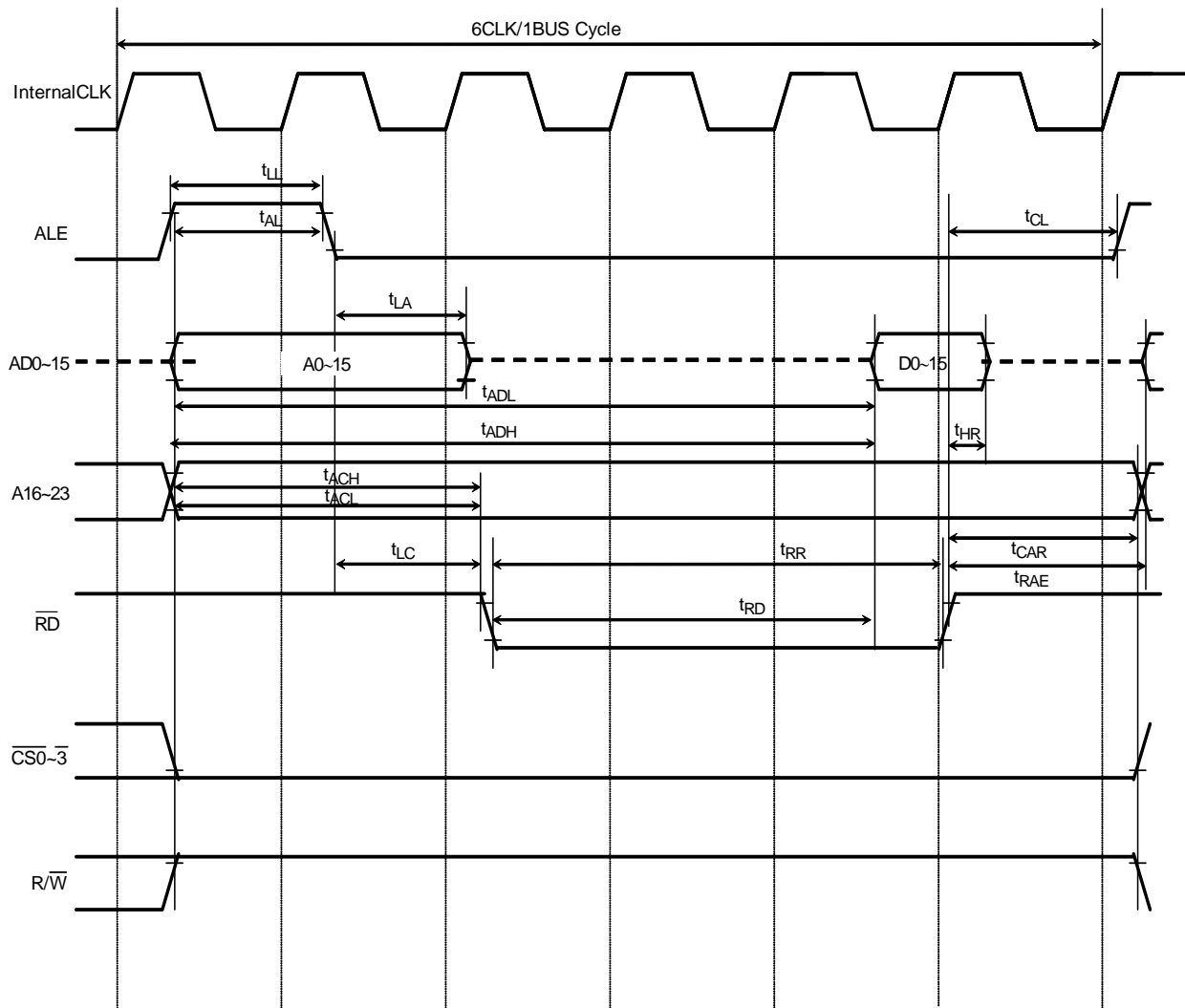

(3) Read cycle timing, ALE width = 1 clock cycle, 4 programmed wait state

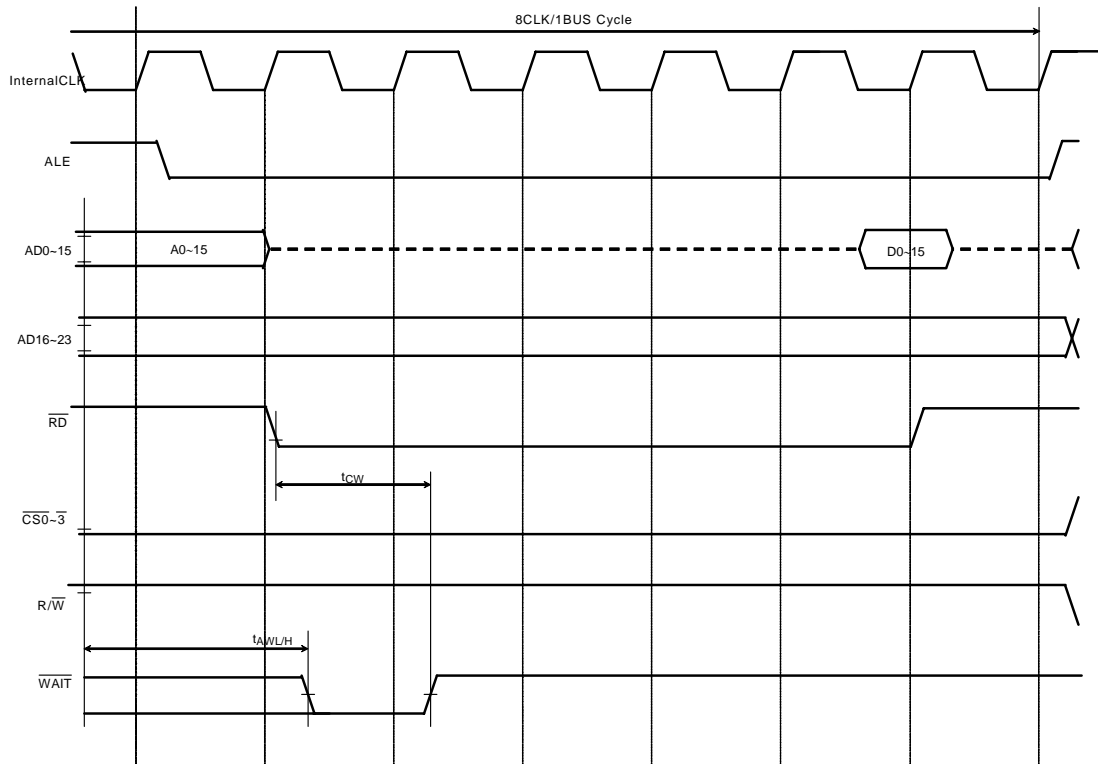

(4) Read cycle timing, ALE width = 2 clock cycle, 1 programmed wait state

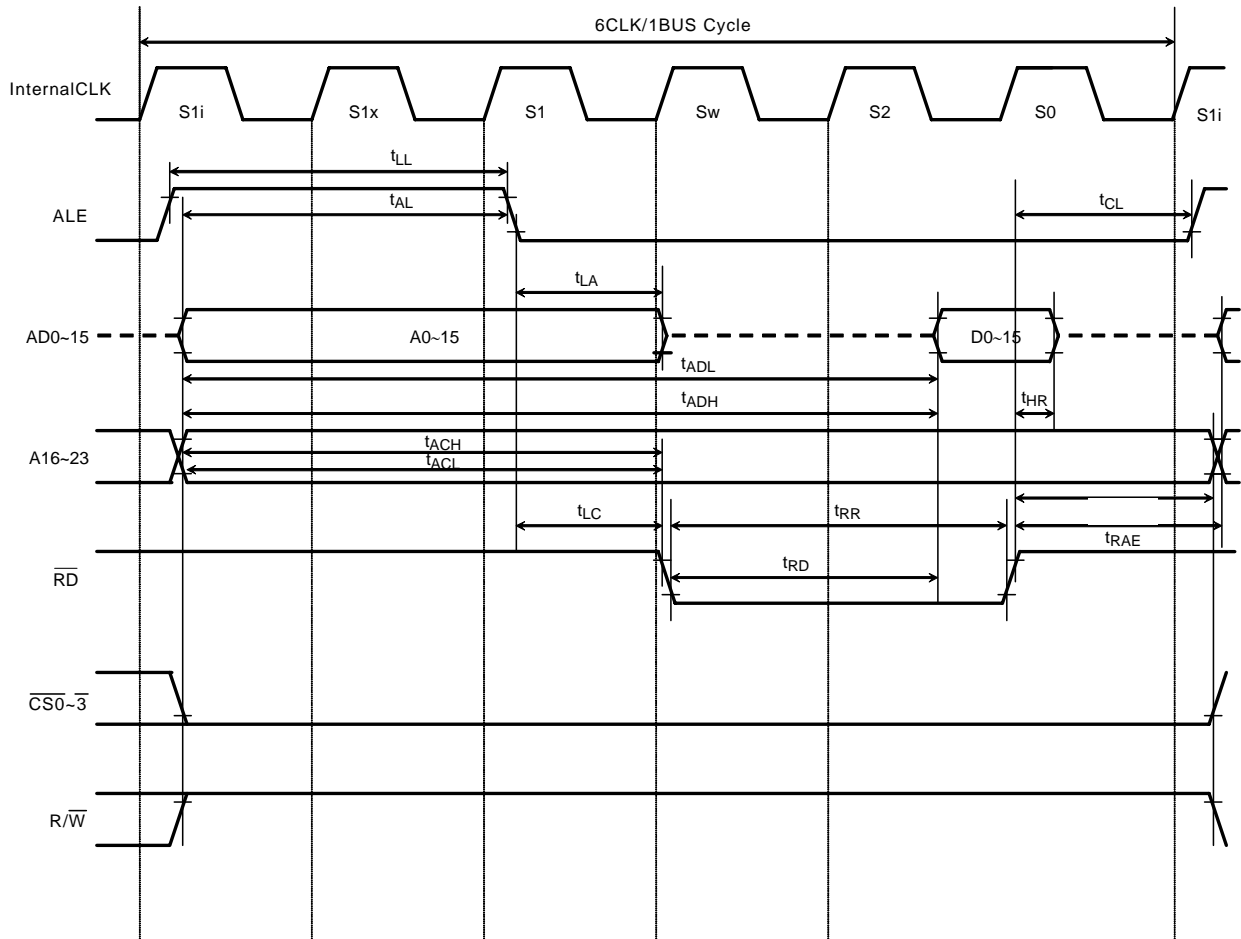

(5) Read cycle timing, ALE width = 2 clock cycle, 4 programmed wait state

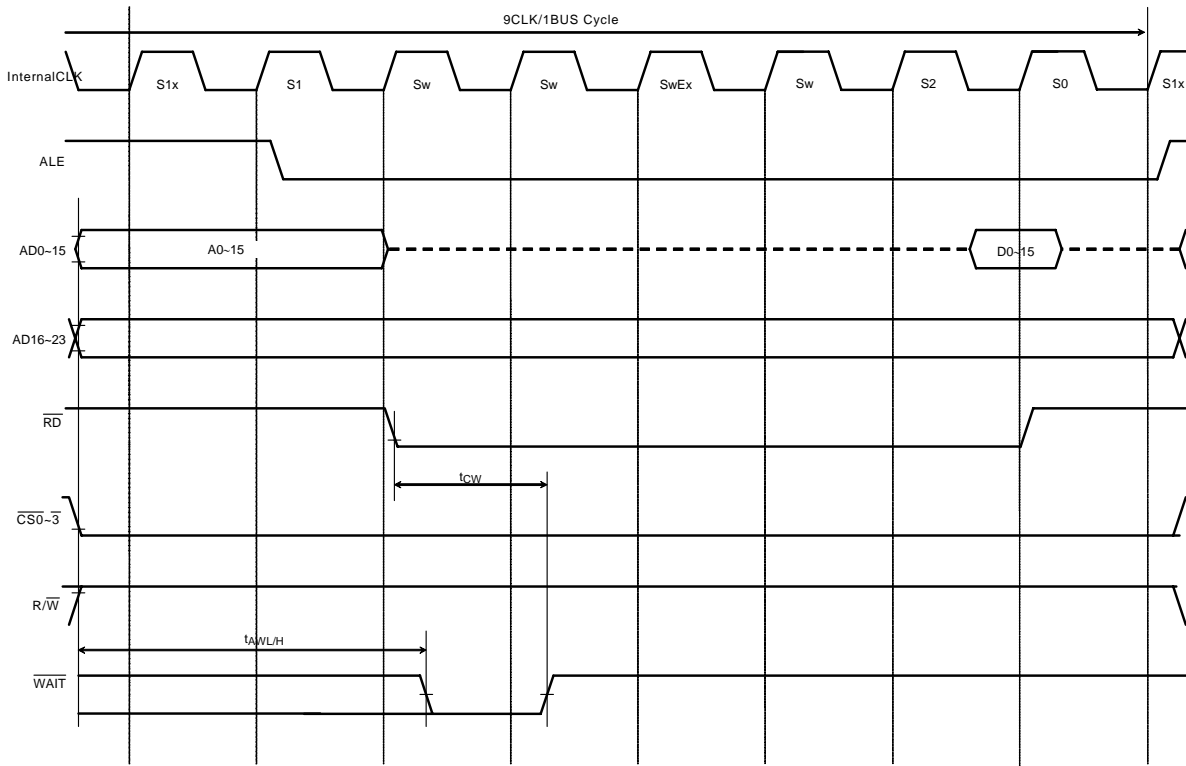

(6) Write cycle timing, ALE width = 2 clock cycles, zero wait state

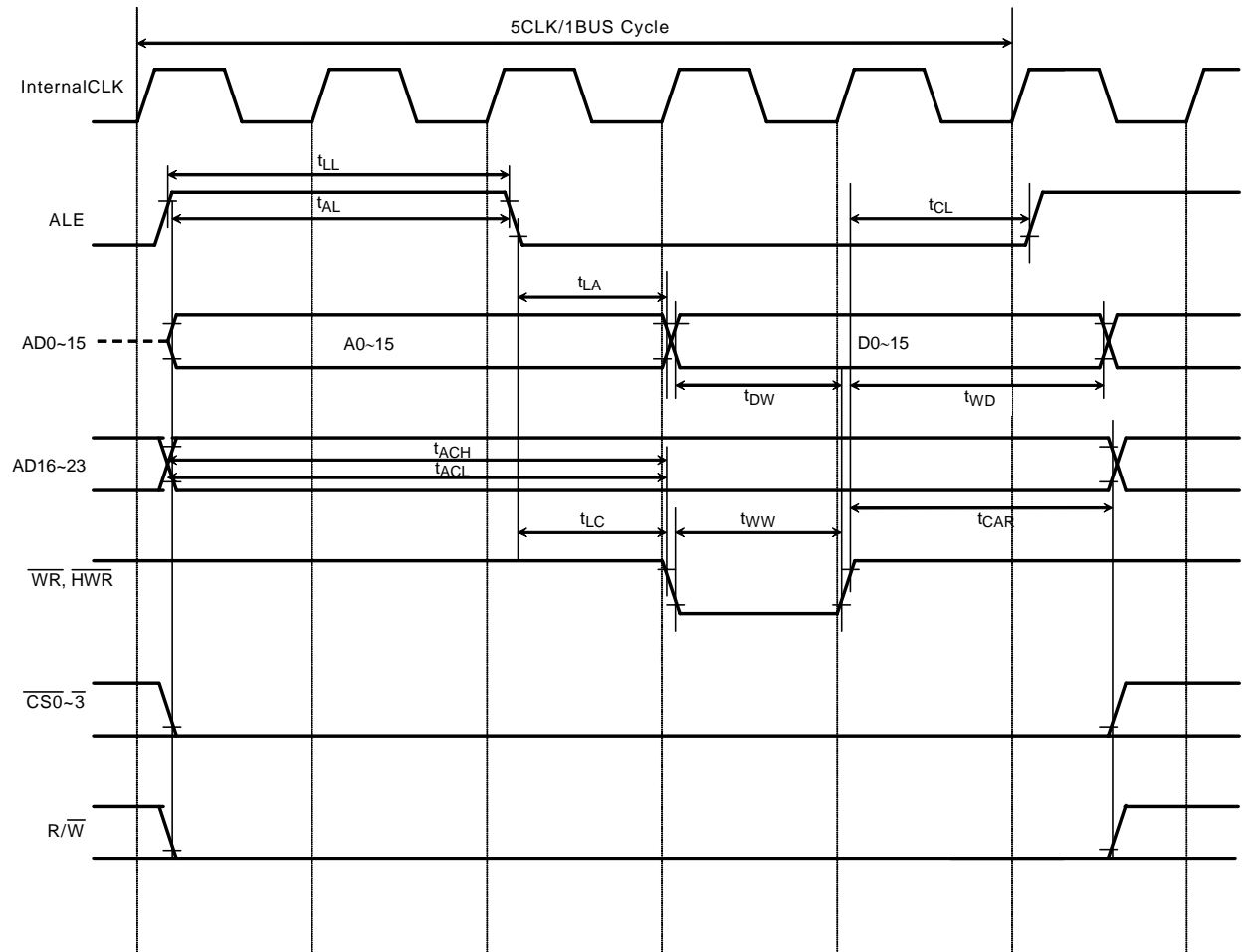

(7) Write cycle timing, ALE width = 1 clock cycles, 2 wait state

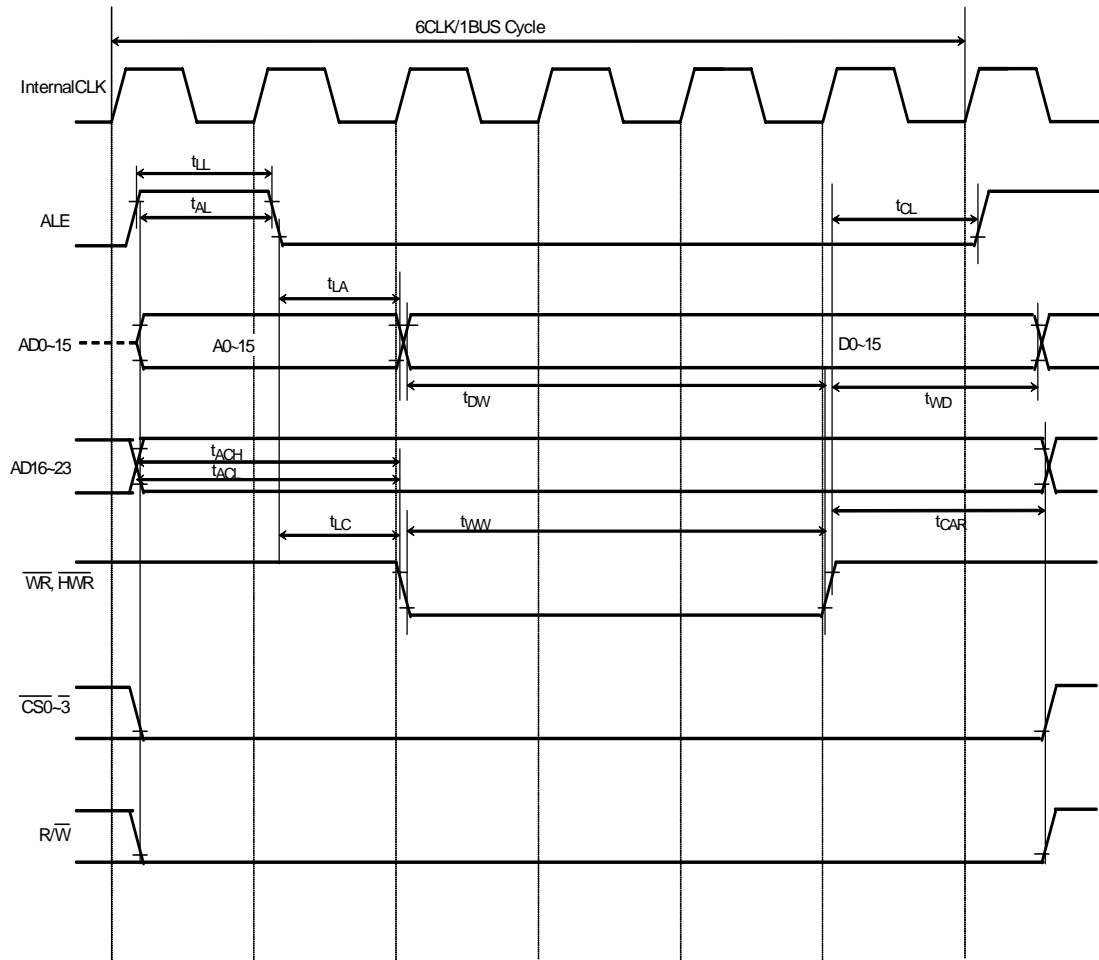

(8) Write cycle timing, ALE width = 2 clock cycles, 4 wait state

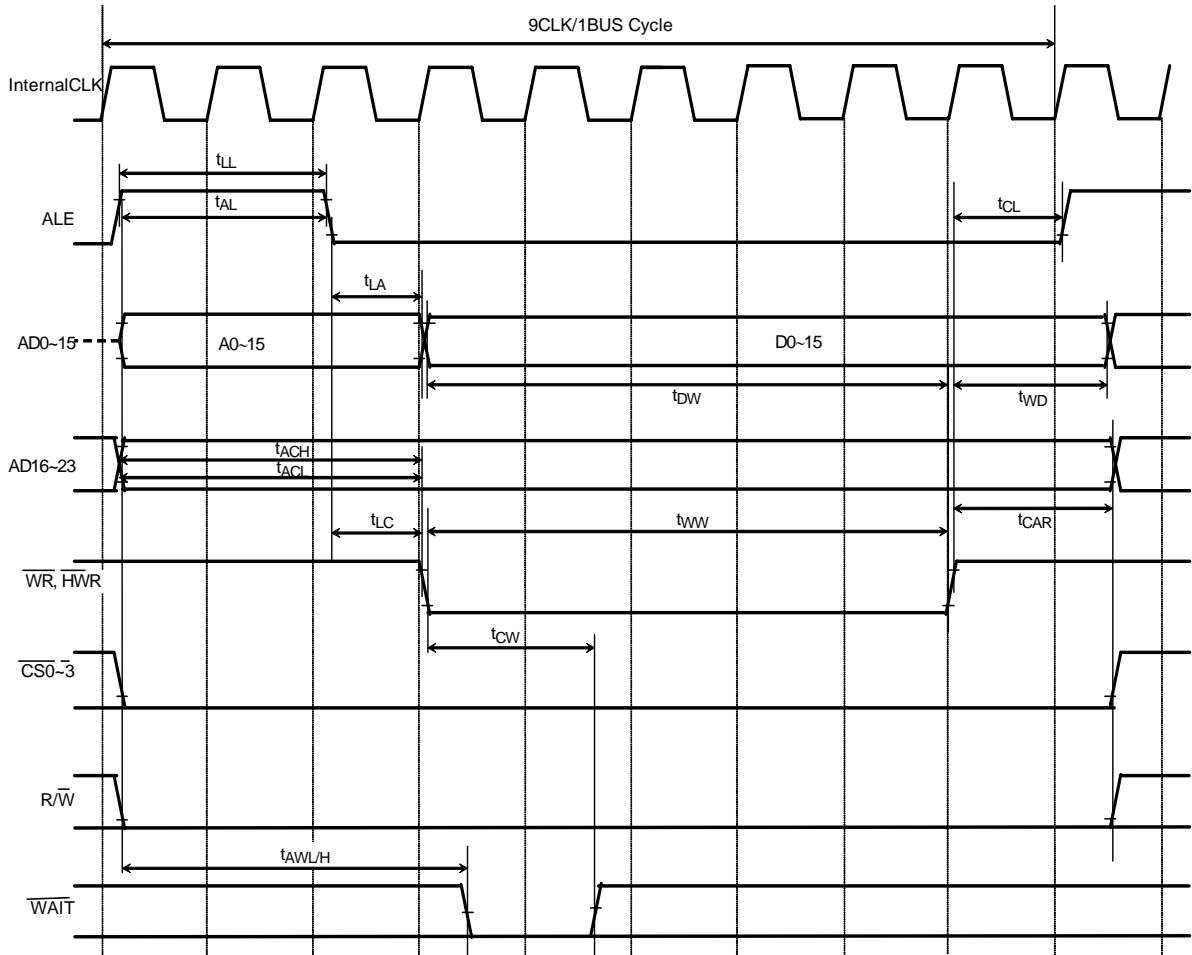

5.7.2 Separate Bus mode

- (1) DVCC15=CVCCCH=1.35Vto1.65V, DVCC3=AVCC3=2.7Vto3.6V,
DAVCC =2.3 Vto2.7V, Ta = -20 to 85°C

① SYSCR3<ALESEL> = "0", 2 programmed wait state

No.	Parameter	Symbol	Equation		40 MHz (f _{sys})(Note)		Unit
			Min	Max	Min	Max	
1	System clock period (x)	t _{SYS}	25				ns
2	A0-A23 valid to \overline{RD} , \overline{WR} or \overline{HWR} asserted	t _{AC}	X(1+ALE) -11		39.0		ns
3	A0-A23 hold after \overline{RD} , \overline{WR} or \overline{HWR} negated	t _{CAR}	x - 11		14.0		ns
4	A0-A23 valid to D0-D15 Data in	t _{AD}		x (2 + TW+ALE) - 43		82.0	ns
5	\overline{RD} asserted to D0-D15 data in	t _{RD}		x (1 + TW) - 40		35.0	ns
6	\overline{RD} width low	t _{RR}	x (1 + TW) - 6		69.0		ns
7	D0-D15 hold after \overline{RD} negated	t _{HR}	0		0		ns
8	\overline{RD} negated to next A0-A23 output	t _{RAE}	x - 6		19.0		ns
9	\overline{WR} / \overline{HWR} width low	t _{WW}	x (1 + TW) - 6		69.0		ns
10	\overline{WR} or \overline{HWR} asserted to D0-D15 valid	t _{DO}		9.7		9.7	ns
11	D0-D15 hold after \overline{WR} or \overline{HWR} negated	t _{DW}	x (1 + TW) - 11		64.0		ns
12	D0-D15 hold after \overline{WR} or \overline{HWR} negated	t _{WD}	x - 11		14.0		ns
13	A0-A23 valid to \overline{WAIT} input	t _{AW}		x + x (ALE) + x (TW - 1) - 32		43.0	ns
14	\overline{WAIT} hold after \overline{RD} , \overline{WR} or \overline{HWR} asserted	t _{CW}	x (TW - 3) - 16	x (TW - 1) - 29	9.0	46.0	ns

Note 1: No. 1 to 14:

Internal 2 wait insertion , ALE "1" Clock, @40MHz

$$TW = W + 2N$$

W : Number of Auto wait insertion , 2N : Number of external wait insertion

$$TW = 2 + 2*1 = 4$$

AC measurement conditions:

Output levels: High = 0.8DVCC3 V/Low 0.2DVCC3 V, CL = 30 pF

Input levels: High = 0.7DVCC3 V/Low 0.3DVCC3 V

(1) Read cycle timing (SYSCR3<ALESEL> = 0, 1 programmed wait state)

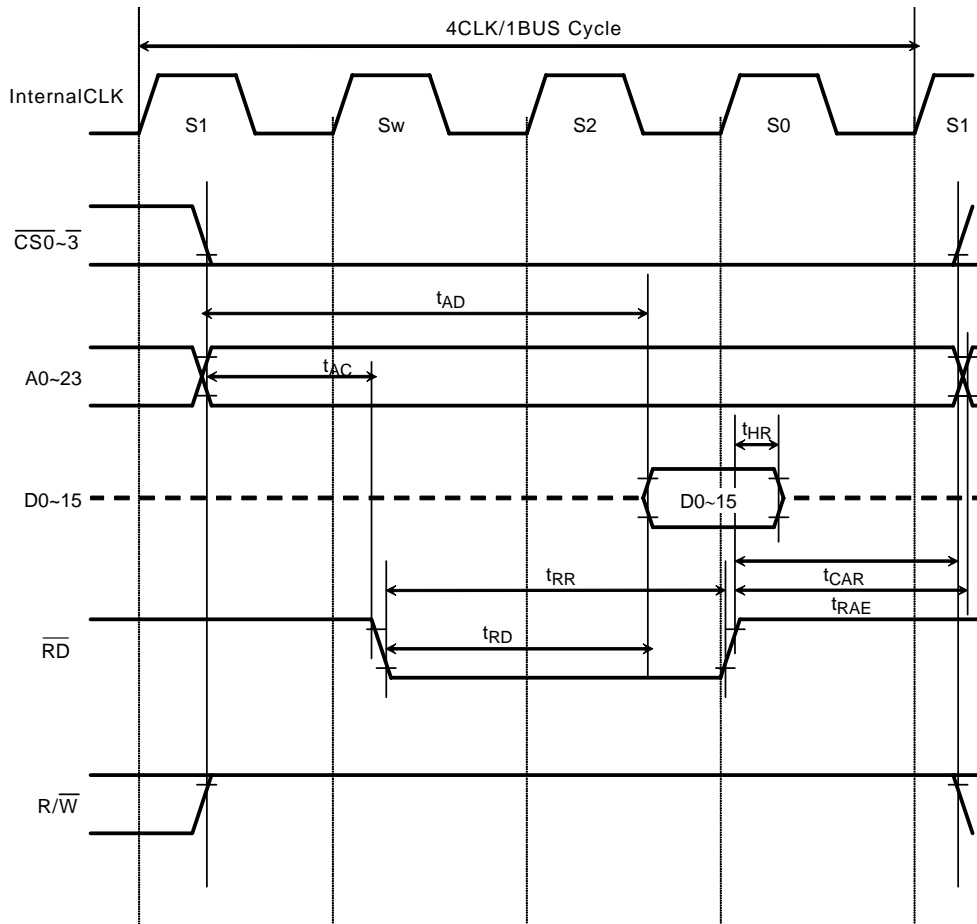

(2) Read cycle timing (SYSCR3<ALESEL> = 1, 1 programmed wait state)

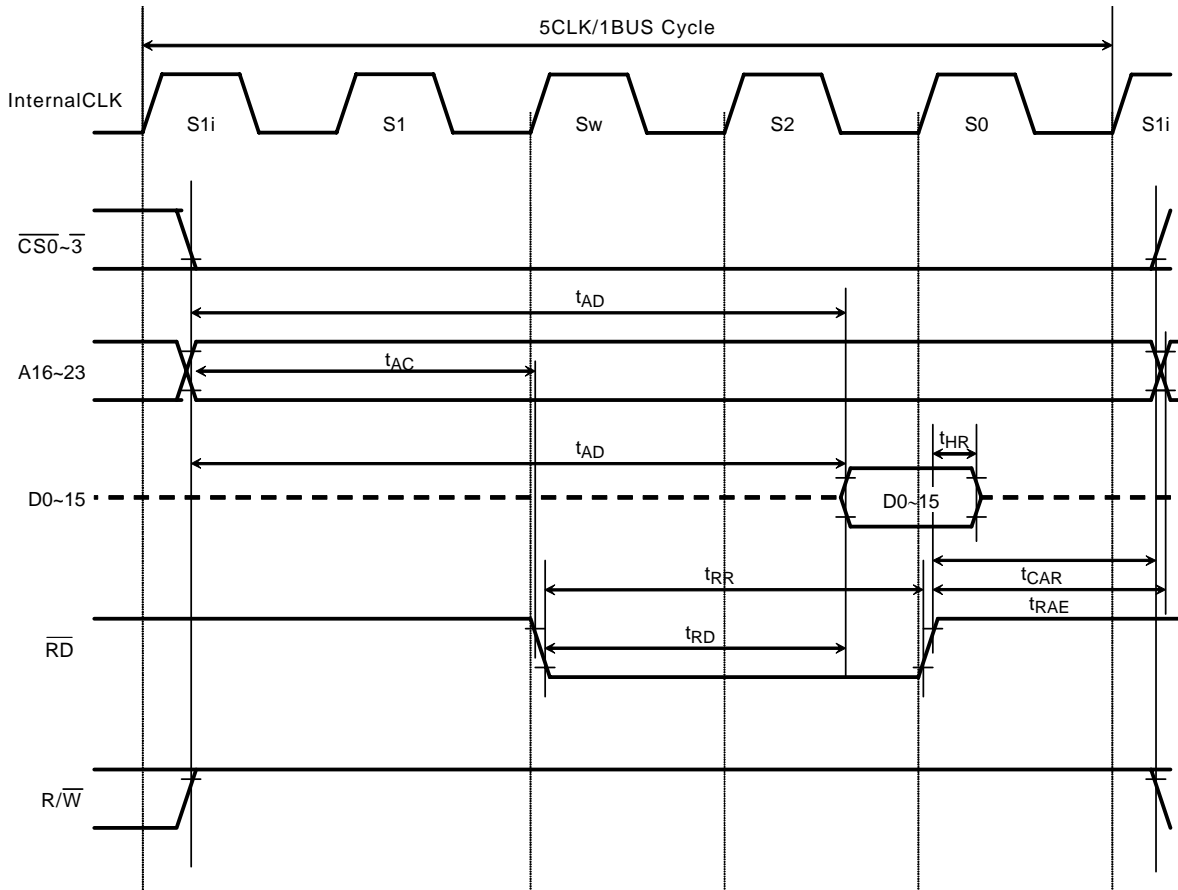

(3) Read cycle timing SYSCR3<ALESEL> = 1, 4 externally generated wait states with N = 1)

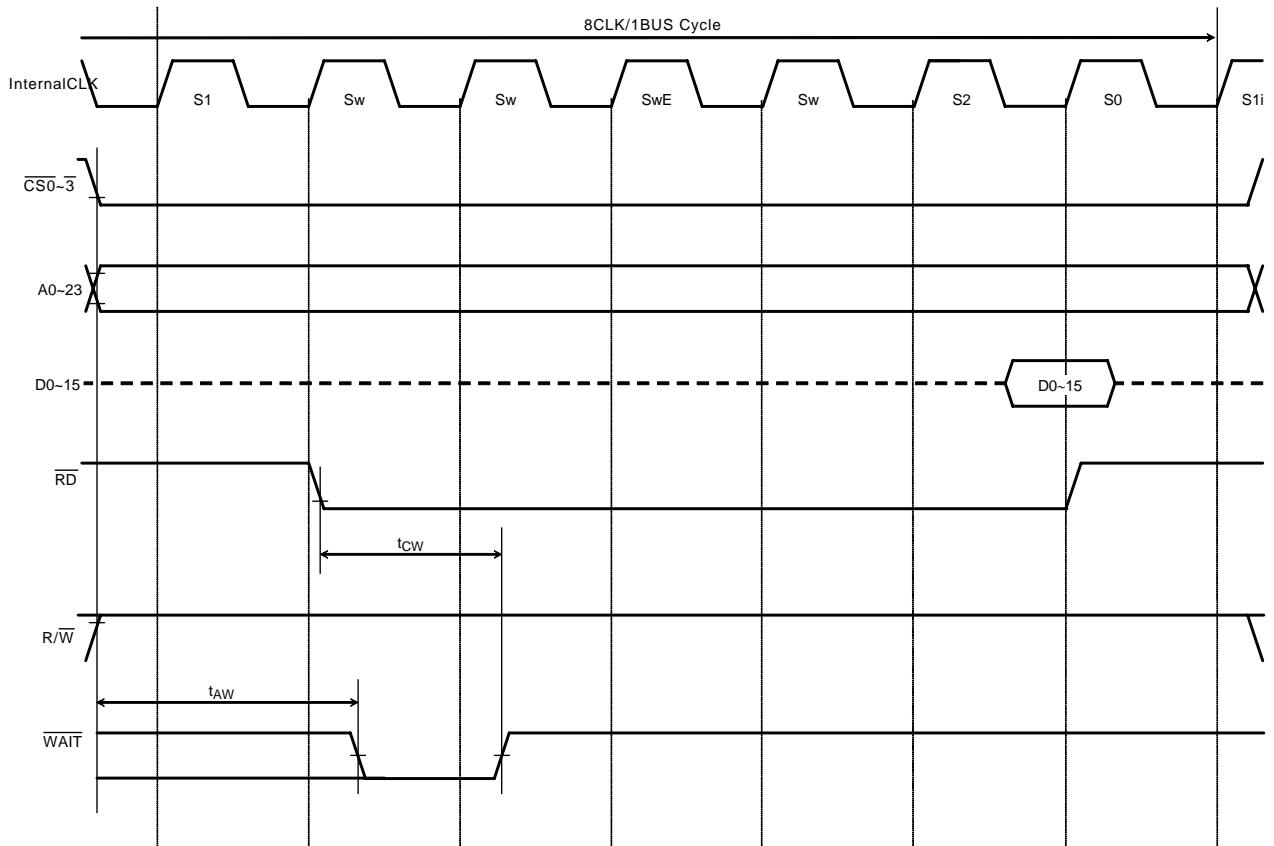

(4) Write cycle timing (SYSCR3<ALESEL> = 1, zero wait state)

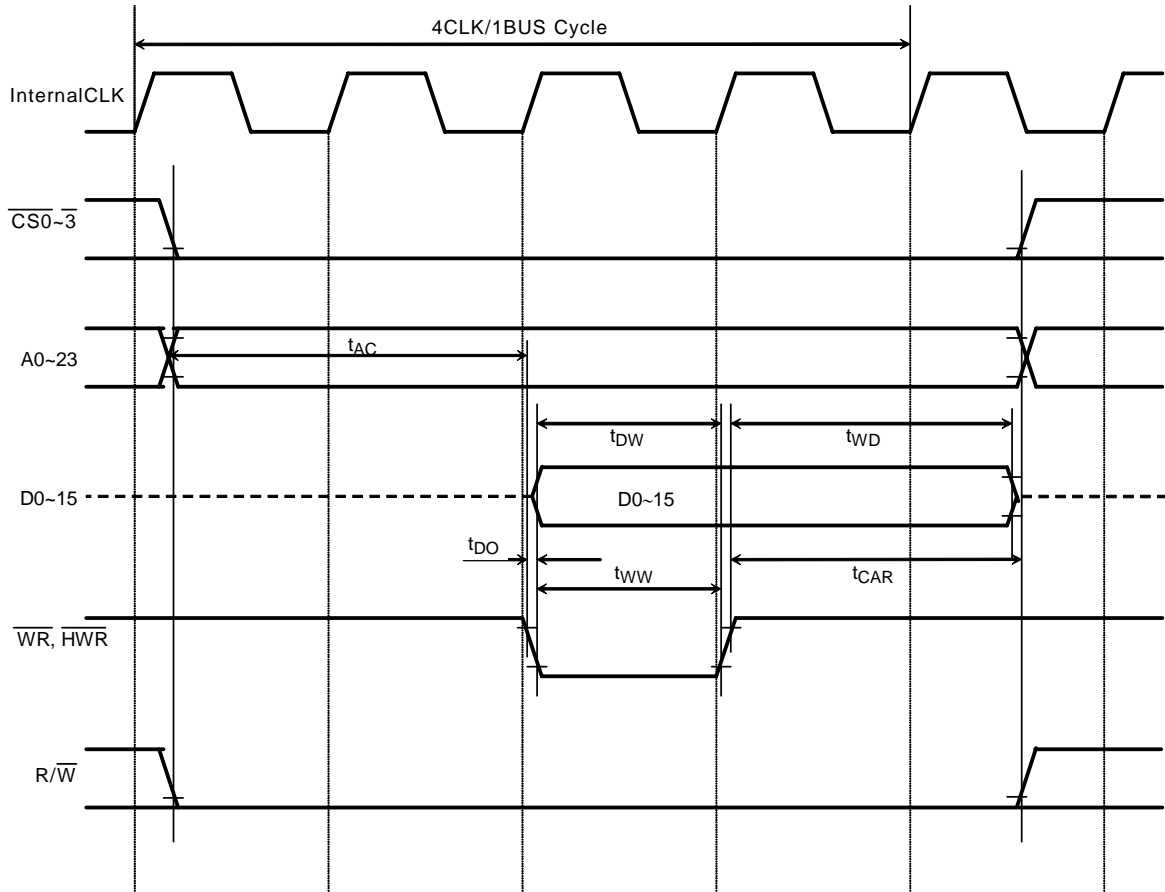

(5) Write cycle timing (SYSCR3<ALESEL> =1, 4 wait state)

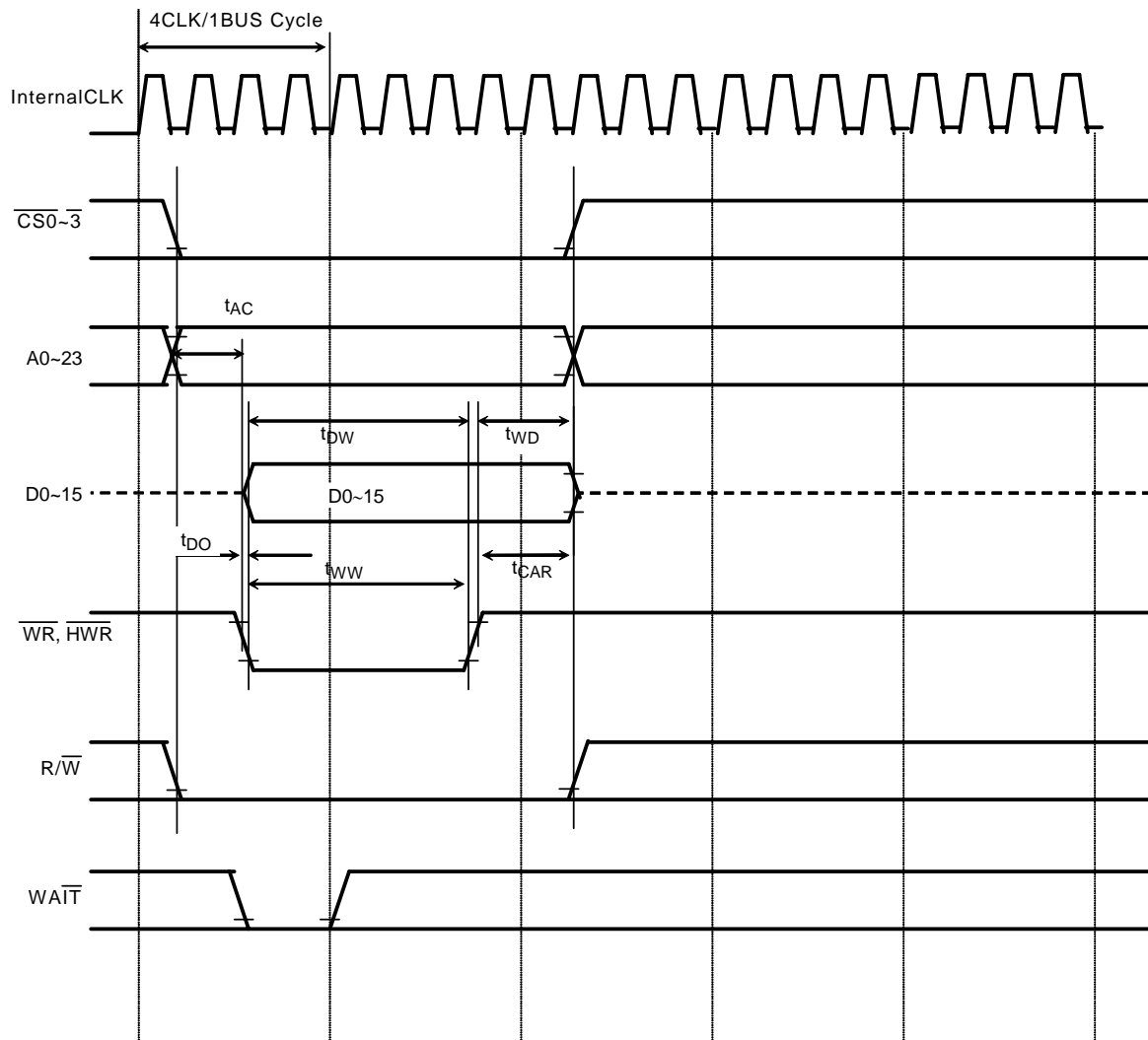

(6) Write cycle timing (SYSCR3<ALESEL> = 1, 5 wait state)

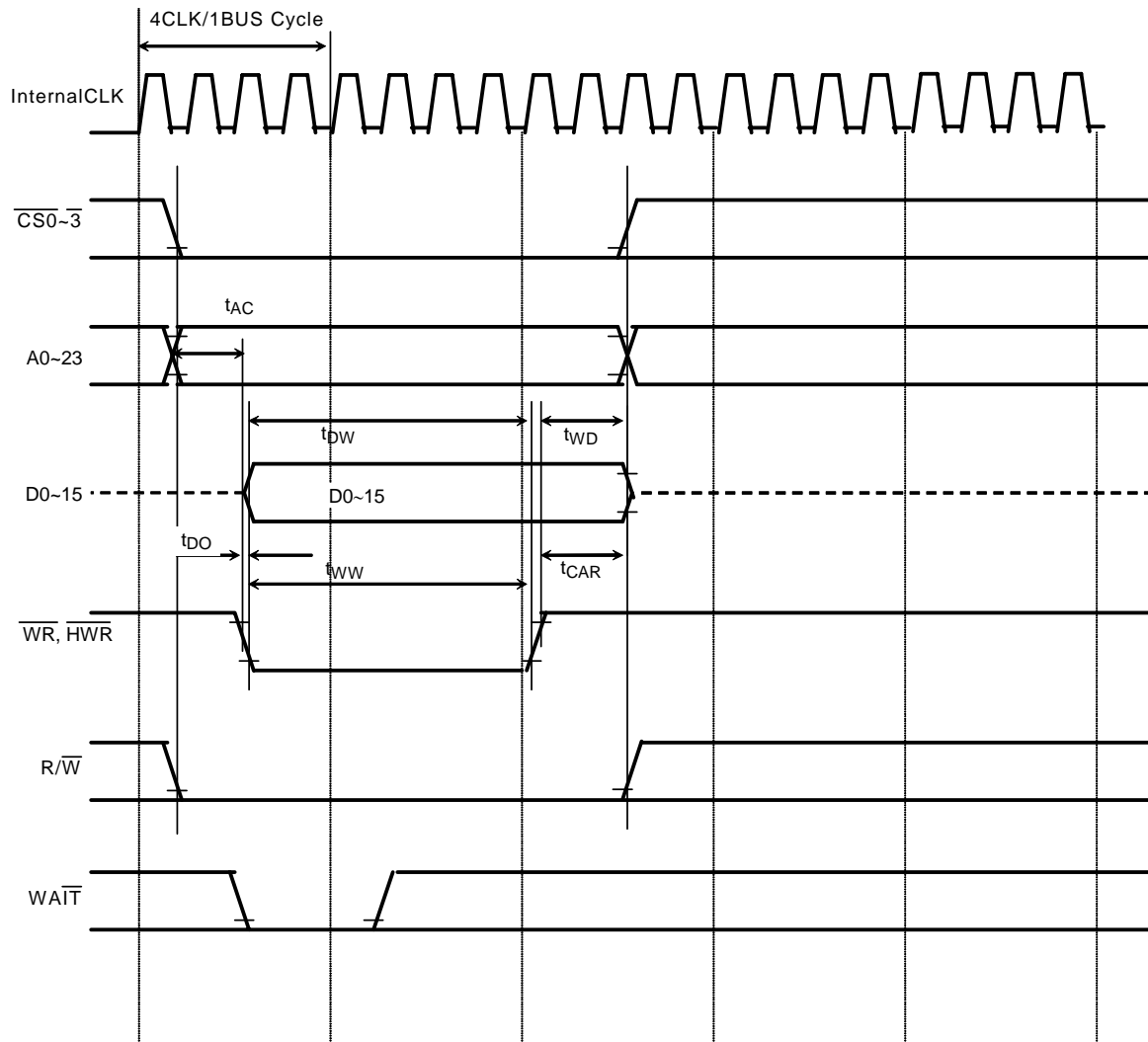

5.8 Transfer with DMA Request

The following shows an example of a transfer between the on-chip RAM and an external device in multiplex bus mode.

- 16-bit data bus width, non-recovery time
- Level data transfer mode
- Transfer size of 16 bits, device port size (DPS) of 16 bits
- Source/destination: on-chip RAM/external device

The following shows transfer operation timing of the on-chip RAM to an external bus during write operation (memory-to-memory transfer).

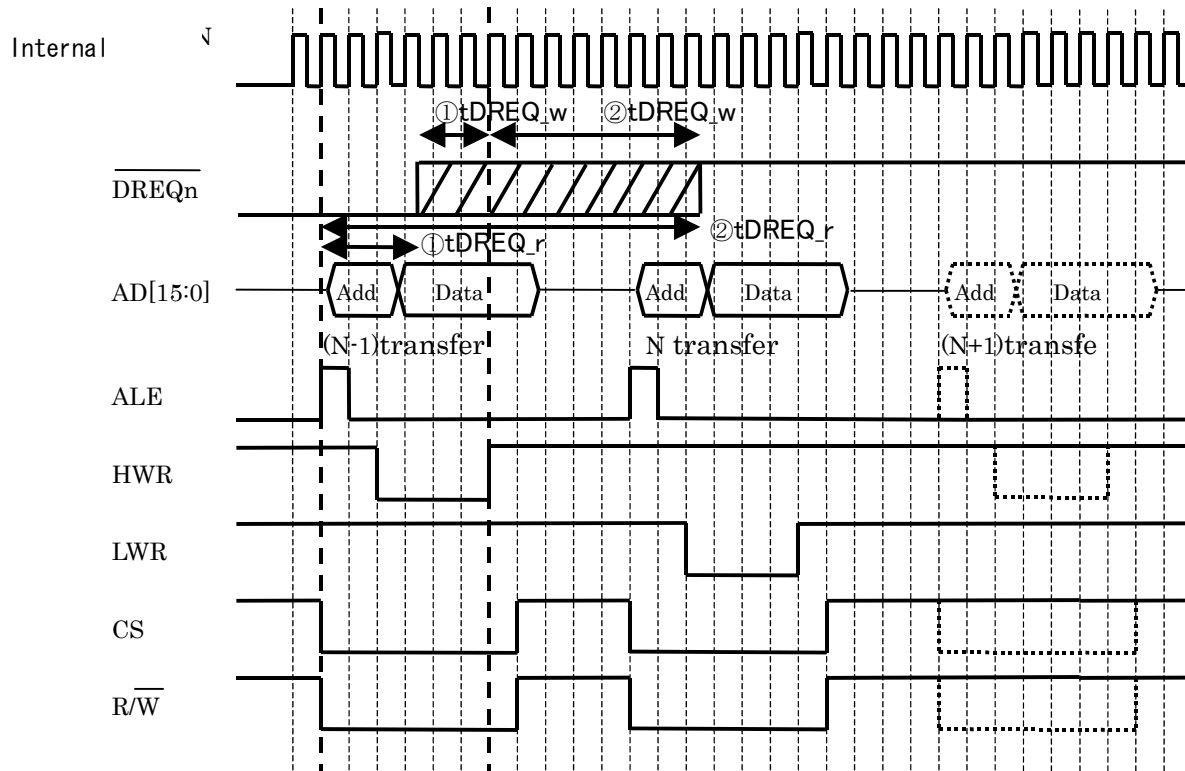

- (1) Indicates the condition under which Nth transfer is performed successfully.
- (2) Indicates the condition under which (N + 1)th transfer is not performed.

DVCC15=CVCCH=1.35Vto1.65V, DVCC3=AVCC3=2.7Vto3.6V,
DAVCC =2.3 Vto2.7V, Ta = -20to85°C

Parameter	Symbol	Equation		40 MHz (fsys)		Unit
		①Min	②Max	Min	Max	
\overline{RD} asserted to \overline{DREQn} negated (external device to on-chip RAM transfer)	tDREQ_r	$(W+1)x$	$(2W+ALE+8)x$ -51	50	224	ns
$\overline{WR} / \overline{HWR}$ rising to \overline{DREQn} negated (on-chip RAM to external device transfer)	tDREQ_w	$-(W+2)x$	$(5+WAIT)x - 51.8$	-75	98.2	ns

5.9 Serial Channel Timing

(1) I/O Interface mode (DVCC3=2.7Vto3.6V)

In the table below, the letter x represents the fsys cycle period, which varies depending on the programming of the clock gear function.

① SCLK input mode (SIO0 to SIO2)

Parameter	Sym bol	Equation		40 MHz		Unit
		Min	Max	Min	Max	
SCLK period	tSCY	12x		300		ns
SCLK Clock High width(input)	TscH	6x		150		ns
SCLK Clock Low width (input)	TscL	6x		150		ns
TxD data to SCLK rise or fall*	tOSS	2x-30		20		ns
TxD data hold after SCLK rise or fall*	tOHS	8x-15		185		ns
RxD data valid to SCLK rise or fall*	tSRD	30		30		ns
RxD data hold after SCLK rise or fall*	tHSR	2x+30		80		ns

* SCLK rise or fall: Measured relative to the programmed active edge of SCLK.

② SCLK output mode (SIO0 to SIO2)

Parameter	Sym bol	Equation		40 MHz		Unit
		Min	Max	Min	Max	
SCLK period	tSCY	8x		200		ns
TxD data to SCLK rise or fall*	tOSS	4x-10		90		ns
TxD data hold after SCLK rise or fall*	tOHS	4x-10		90		ns
RxD data valid to SCLK rise or fall*	tSRD	45		45		ns
RxD data hold after SCLK rise or fall*	tHSR	0		0		ns

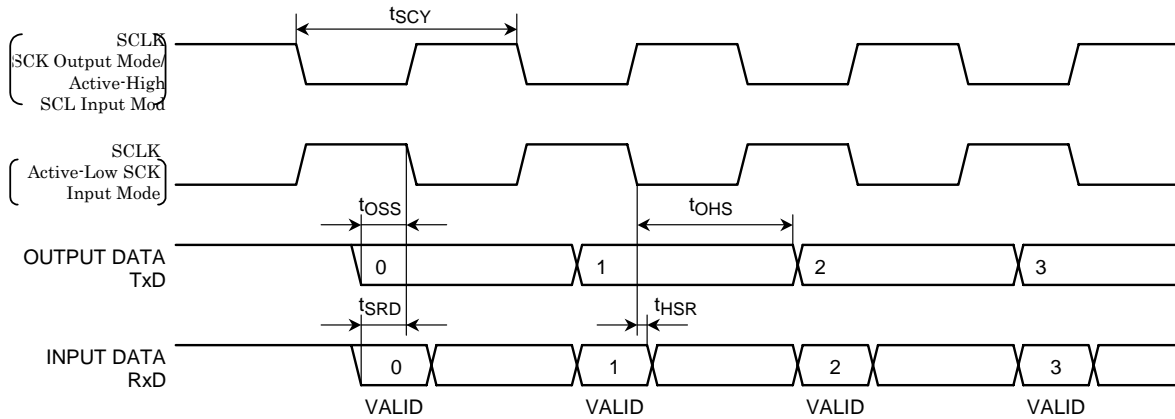

5.10 High Speed Serial Channel Timing

(1) I/O Interface mode (DVCC3=2.7V to 3.6V)

In the table below, the letter x represents the fsys cycle period, which varies depending on the programming of the clock gear function.

① HSCLK input mode (HSI00 to HSI02)

Parameter	Sym bol	Equation		40 MHz		Unit
		Min	Max	Min	Max	
HSCLK period	tSCY	12(x/2)		150		ns
HSCLK Clock High width(input)	TscH	3x		75		ns
HSCLK Clock Low width (input)	TscL	3x		75		ns
TxD data to HSCLK rise or fall*	tOSS	2(x/2)-30		-5		ns
TxD data hold after HSCLK rise or fall*	tOHS	8(x/2)-15		85		ns
RxD data valid to HSCLK rise or fall*	tSRD	30		30		ns
RxD data hold after HSCLK rise or fall*	tHSR	2(x/2)+30		55		ns

* HSCLK rise or fall: Measured relative to the programmed active edge of HSCLK.

② HSCLK output mode (HSIO0 to HSIO2)

Parameter	Sym bol	Equation		40 MHz		Unit
		Min	Max	Min	Max	
HSCLK period	tSCY	8(x/2)		100		ns
TxD data to HSCLK rise or fall*	tOSS	4(x/2)-10		40		ns
TxD data hold after HSCLK rise or fall*	tOHS	4(x/2)-10		40		ns
RxD data valid to HSCLK rise or fall*	tSRD	45		45		ns
RxD data hold after HSCLK rise or fall*	tHSR	0		0		ns

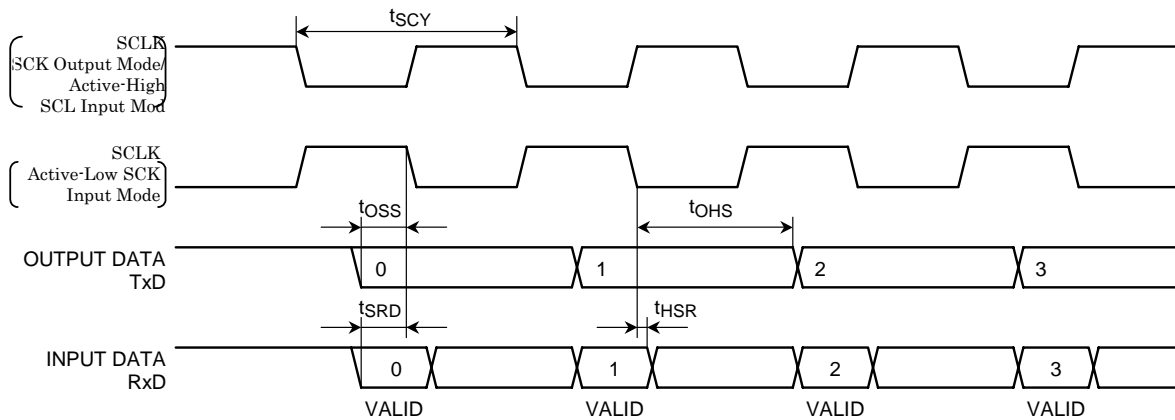

5.11 SBI Timing

(1) I2C mode

In the table below, the letters x represent the fsys periods, respectively.

n denotes the value of n programmed into the SCK (SCL output frequency select) field in the SBI0CR.

Parameter	Symbol	Equation		Standard mode		Fast mode		Unit
		Min	Max	Min	Max	Min	Max	
SCL clock frequency	tSCL	0		0	100	0	400	kHz
Hold time for START condition	tHD;STA			4.0		0.6		μs
SCL clock low width (Input) (Note 1)	tLOW			4.7		1.3		μs
SCL clock high width (Output) (Note 2)	tHIGH			4.0		0.6		μs
Setup time for a repeated START condition	tSU;STA	(Note 5)		4.7		0.6		μs
Data hold time (Input) (Note 3, 4)	tHD;DAT			0.0		0.0		μs
Data setup time	tSU;DAT			250		100		ns
Setup time for STOP condition	tSU;STO			4.0		0.6		μs
Bus free time between STOP and START conditions	tBUF	(Note 5)		4.7		1.3		μs

Note 1: SCL clock low width (output) is calculated with: $(2^{n-1} + 58)/(f_{sys}/2)$

Note 2: SCL clock high width (output) is calculated with $(2^{n-1} + 12)/(f_{sys}/2)$

Notice: On I²C-bus specification, Maximum Speed of Standard Mode is 100KHz ,Fast mode is 400Khz. Internal SCL clock Frequency setting should be shown above Note1 & Note2.

Note 3: The output data hold time is equal to 12x

Note 4: The Philips I²C-bus specification states that a device must internally provide a hold time of at least 300 ns for the SDA signal to bridge the undefined region of the fall edge of SCL. However, this SBI does not satisfy this requirement. Also, the output buffer for SCL does not incorporate slope control of the falling edges; therefore, the equipment manufacturer should design so that the input data hold time shown in the table is satisfied, including tr/tf of the SCL and SDA lines.

Note 5: Software-dependent

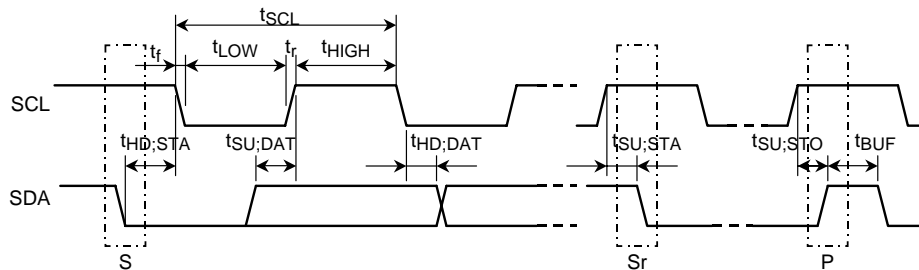

S: START condition
 Sr: Repeated START condition
 P: STOP condition

(2) Clock-Synchronous 8-Bit SIO mode

In the tables below, the letters x represent the fsys cycle periods, respectively. The letter n denotes the value of n programmed into the SCK (SCL output frequency select) field in the SBI0CR1.

The electrical specifications below are for an SCK signal with a 50% duty cycle.

③ SCK Input mode

Parameter	Symbol	Equation		40 MHz		Unit
		Min	Max	Min	Max	
SCK period	tSCY	16x		400		ns
SCK Clock High width(input)	TscH	8x		200		ns
SCKClock Low width(input)	TscL	8x		200		ns
SO data to SCK rise	tOSS	$(tSCY/2) - (6x + 20)$		30		ns
SO data hold after SCK rise	tOHS	$(tSCY/2) + 4x$		300		ns
SI data valid to SCK rise	tSRD	0		0		ns
SI data hold after SCK rise	tHSR	4x + 10		110		ns

④ SCK Output mode

Parameter	Symbol	Equation		40 MHz		Unit
		Min	Max	Min	Max	
SCK period (programmable)	tscy	$2^n \cdot T$		800		ns
SO data to SCK rise	toss	$(tscy/2) - 20$		380		ns
SO data hold after SCK rise	tohs	$(tscy/2) - 20$		T380		ns
SI data valid to SCK rise	tsrd	2x + 30		55		ns
SI data hold after SCK rise	tHSR	0		0		ns

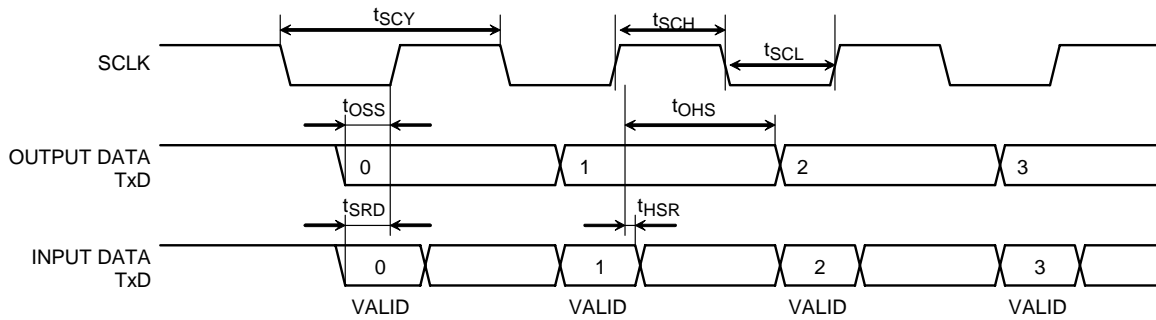

5.12 Event Counter

In the table below, the letter x represents the fsys cycle period.

Parameter	Symbol	Equation		40 MHz		Unit
		Min	Max	Min	Max	
Clock low pulse width	t_{VCKL}	$2X + 100$		150		ns
Clock high pulse width	t_{VCKH}	$2X + 100$		150		ns

5.13 Timer Capture

In the table below, the letter x represents the fsys cycle period.

Parameter	Symbol	Equation		40 MHz		Unit
		Min	Max	Min	Max	
Low pulse width	t_{CPL}	$2X + 100$		150		ns
High pulse width	t_{CPH}	$2X + 100$		150		ns

5.14 General Interrupts

In the table below, the letter x represents the fsys cycle period.

Parameter	Symbol	Equation		40 MHz		Unit
		Min	Max	Min	Max	
Low pulse width for INT0-INTA	t_{INTAL}	$X + 100$		125		ns
High pulse width for INT0-INTA	t_{INTAH}	$X + 100$		125		ns

5.15 STOP /SLEEP/SLOW Wake-up Interrupts

Parameter	Symbol	Equation		40 MHz		Unit
		Min	Max	Min	Max	
Low pulse width for INT0-INTB	t_{INTBL}	100		100		ns
High pulse width for INT0-INTB	t_{INTBH}	100		100		ns

5.16 SCOUT Pin

Parameter	Symbol	Equation		40 MHz		Unit
		Min	Max	Min	Max	
Clock high pulse width	t_{SCH}	$0.5T - 5$		7.5		ns
Clock low pulse width	t_{SCL}	$0.5T - 5$		7.5		ns

Note: In the above table, the letter T represents the cycle period of the SCOUT output clock.

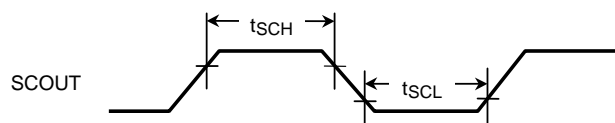

5.17 Bus Request and Bus Acknowledge Signals

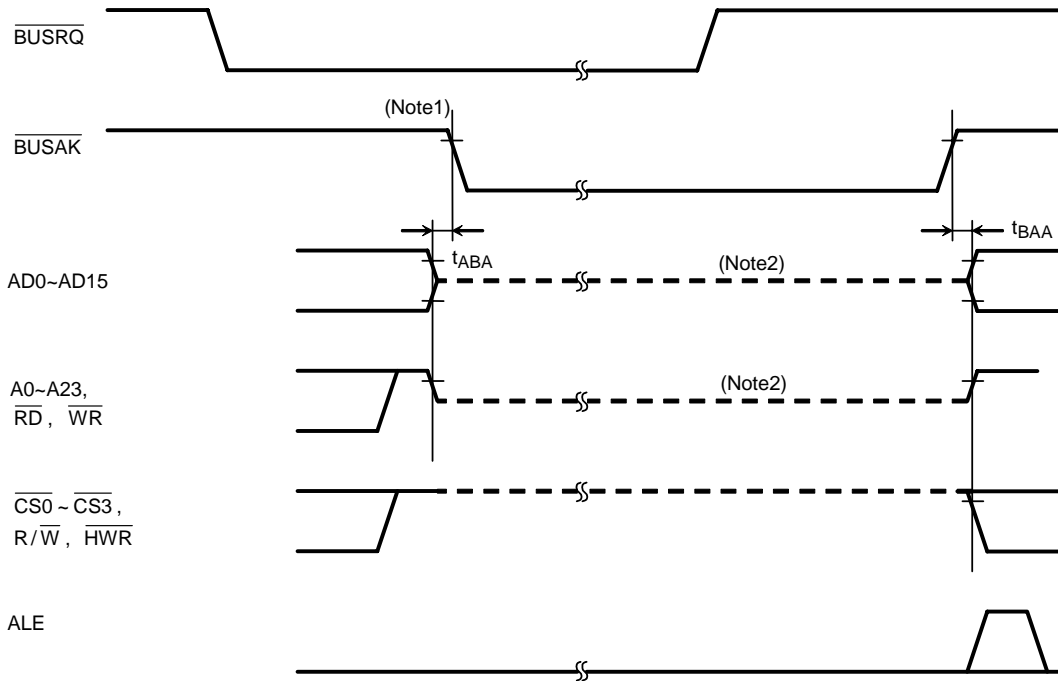

Parameter	Symbol	Equation		40 MHz		Unit
		Min	Max	Min	Max	
Bus float to $\overline{\text{BUSAK}}$ asserted	t_{ABA}	0	80	0	80	ns
Bus float after $\overline{\text{BUSAK}}$ negated	t_{BAA}	0	80	0	80	ns

Note 1: If the current bus cycle has not terminated due to wait-state insertion, the TMP19A43FDXBG does not respond to $\overline{\text{BUSRQ}}$ until the wait state ends.

Note 2: This broken line indicates that output buffers are disabled, not that the signals are at indeterminate states. The pin holds the last logic value present at that pin before the bus is relinquished. This is dynamically accomplished through external load capacitances. The equipment manufacturer may maintain the bus at a predefined state by means of off-chip restores, but he or she should design, considering the time (determined by the CR constant) it takes for a signal to reach a desired state. The on-chip, integrated programmable pullup/pulldown resistors remain active, depending on internal signal states.

5.18 KWUP Input

Parameter	Symbol	Equation		40 MHz		Unit
		Min	Max	Min	Max	
Low pulse width for KEY	$t_{KY_{TBL}}$	100		100		ns
High pulse width for KEY	$t_{KY_{TBH}}$	100		100		ns

5.19 Dual Pulse Input

Parameter	Symbol	Equation		40 MHz		Unit
		Min	Max	Min	Max	
Dual input pulse period	T_{dcyc}	$8Y$		400		ns
Dual input pulse setup	T_{abs}	$Y+20$		70		ns
Dual input pulse hold	T_{abh}	$Y+20$		70		ns

$Y : f_{sys}/2$

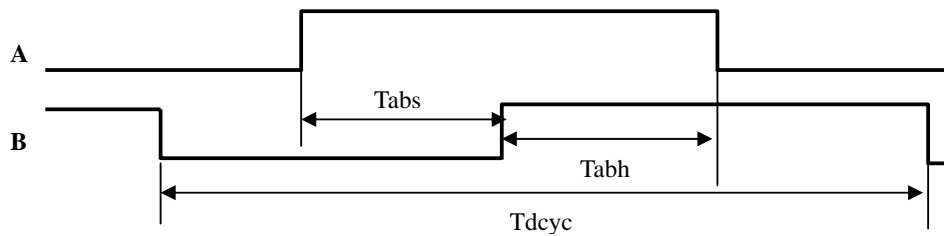

5.20 ADTRG input

Parameter	Symbol	Equation		40 MHz		Unit
		Min	Max	Min	Max	
Low pulse width for ADTRG	t_{ad_L}	$f_{sys}/2 + 20$		32.5		ns
High pulse width for ADTRG	T_{adh}	$f_{sys}/2 + 20$		32.5		ns

5.21 DSU

Parameter	Symbol	Equation		40 MHz		Unit
		Min	Max	Min	Max	
PCST valid to DCLK negated	Tsetup	11		11		ns
PCST hold after DCLK negated	Thold	0.5		0.5		ns
TPC valid to DCLK negated	Tsetup	11		11		ns
TPC hold after DCLK negated	Thold	0.5		0.5		ns
TPD valid to DCLK negated	Tsetup	11		11		ns
TPD hold after DCLK negated	Thold	0.5		0.5		ns

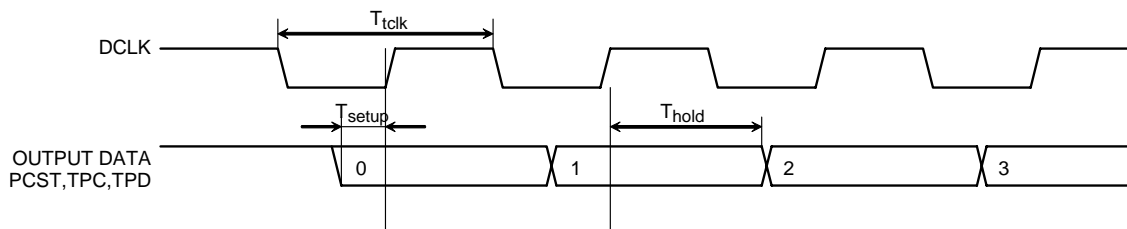

5.22 EJTAG

Parameter	Symbol	Equation		10 MHz (※)		Unit
		Min	Max	Min	Max	
TCK valid to TMS/TDI Data in	Ttsetup	40		40		ns
TMS/TDI hold after TCK negated	Tthold	50		50		ns
TDO hold after TCK asserted	Tt _{out}		10		10	ns

※ Operating Frequency of TCK is 10MHz Only

