

## Ultrasound Transmit/Receive Switch

### General Description

The LM96530 is an eight-channel monolithic high-voltage, high-speed T/R (Transmit/Receive) switch for multi-channel medical ultrasound applications. It is well-suited for use with National's LM965XX series chipset which offers a complete medical ultrasound solution targeted towards low-power, portable systems.

The LM96530 contains eight high-voltage T/R switches with integrated clamping diodes. This chip protects the inputs of the receive channel's LNA (Low Noise Amplifier) from the high-voltage pulses of the transmit channel. Advanced features include a diode bridge with internal current sources that are programmable via an external resistor. Low-power operation is enabled via per-channel-selectable switching.

National Semiconductor also offers a development package for sale which includes a driver hardware and software package with a graphical user interface for configuration and monitoring.

### Applications

- Ultrasound Imaging

### Features

- 8-channel high-voltage receive side switches without charge-injection
- Can be used for receive protection and/or receive multiplexing with SPI™ compatible bus control
- Channel bandwidth supports 1MHz to 20MHz transducers
- Input accepts pulses and continuous-wave signals within  $\pm 60V$
- Integrated output clamping diodes limit output to  $\pm 0.7V$
- Low harmonic distortion HD2 at -75dBc at 5MHz
- Continuous-wave operation
- Soft-switcher based on a diode bridge architecture yielding better noise performance and faster turn-on and -off times than competing T-gate switch architectures
- 2.5V to 3.3V CMOS SPI™ compatible logic interface with daisy chain capability
- Bias current source ( $I_S$ ) can be scaled between 0 and 8mA via an external resistor

### Key Specifications

Input voltage	$\pm 60$	V
Output voltage clamp ( $I_S = 1mA$ )	$\pm 0.7$	V
On-resistance	18	$\Omega$
Off-isolation @ 5MHz	-58	dB
Noise spectral density @ 5MHz	0.5	nV/ $\sqrt{Hz}$
Harmonic distortion		
HD2	-75	dB
HD3	-75	dB
Channel crosstalk @ 5MHz	-73	dB
Operating Temp.	0 to +70	$^{\circ}C$

## Block Diagram

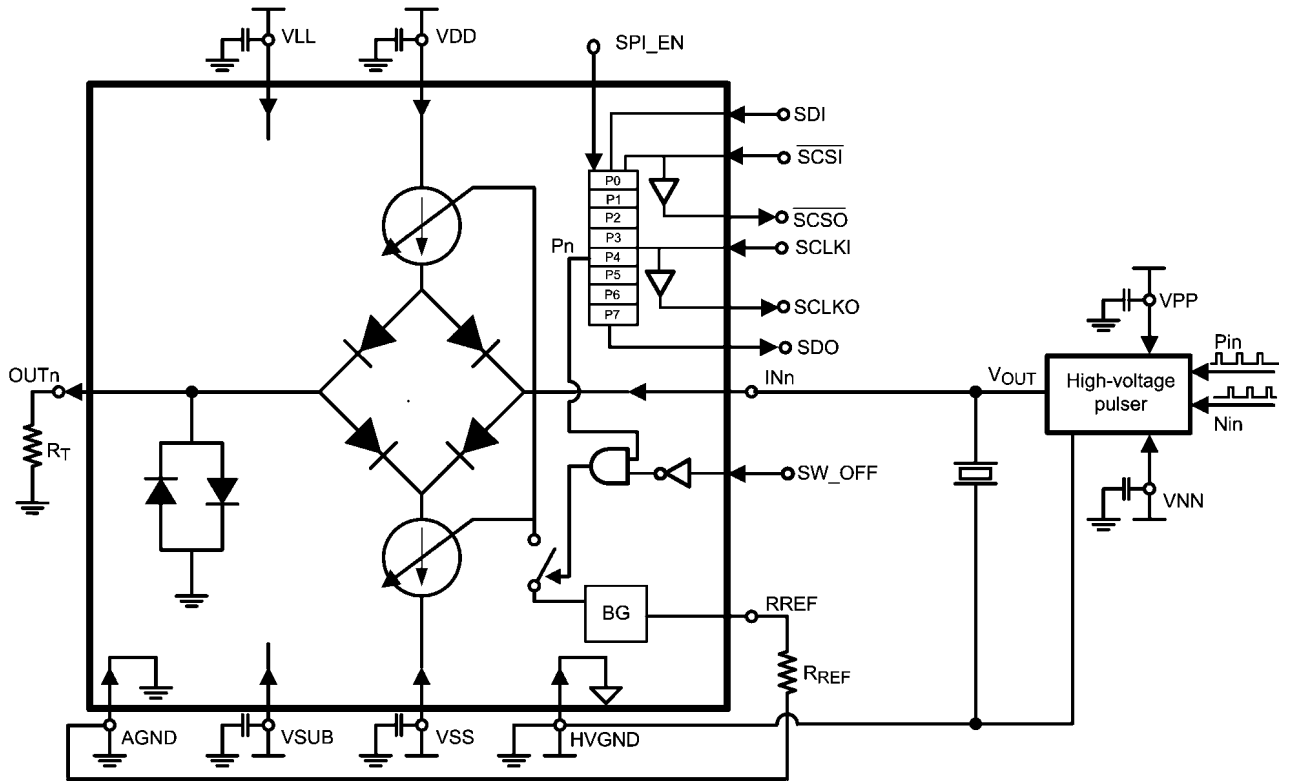

30122002

## Typical Application

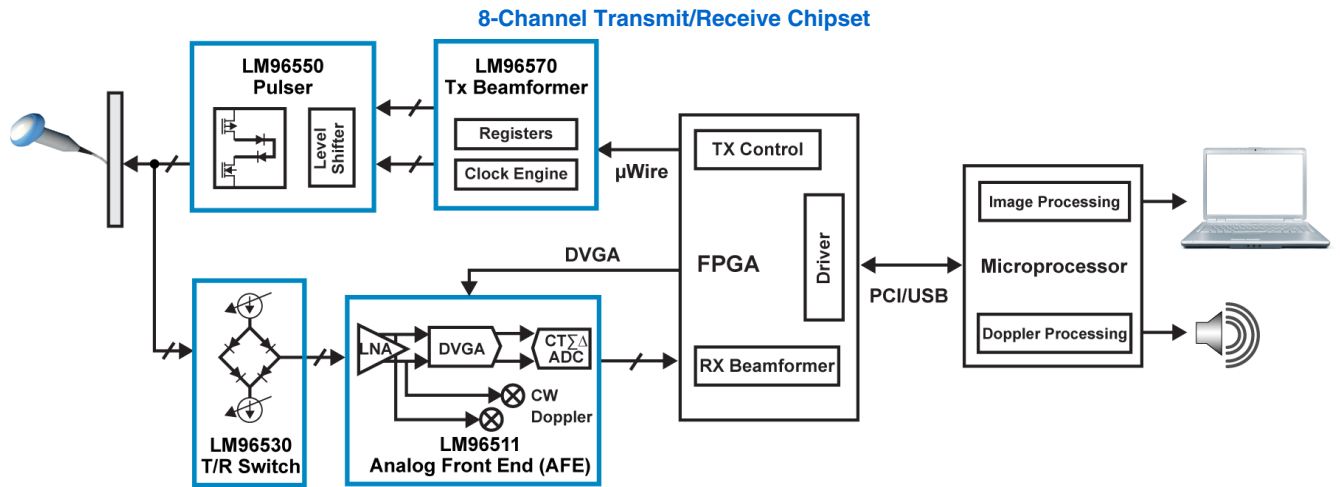

30122007

## Pin Diagram

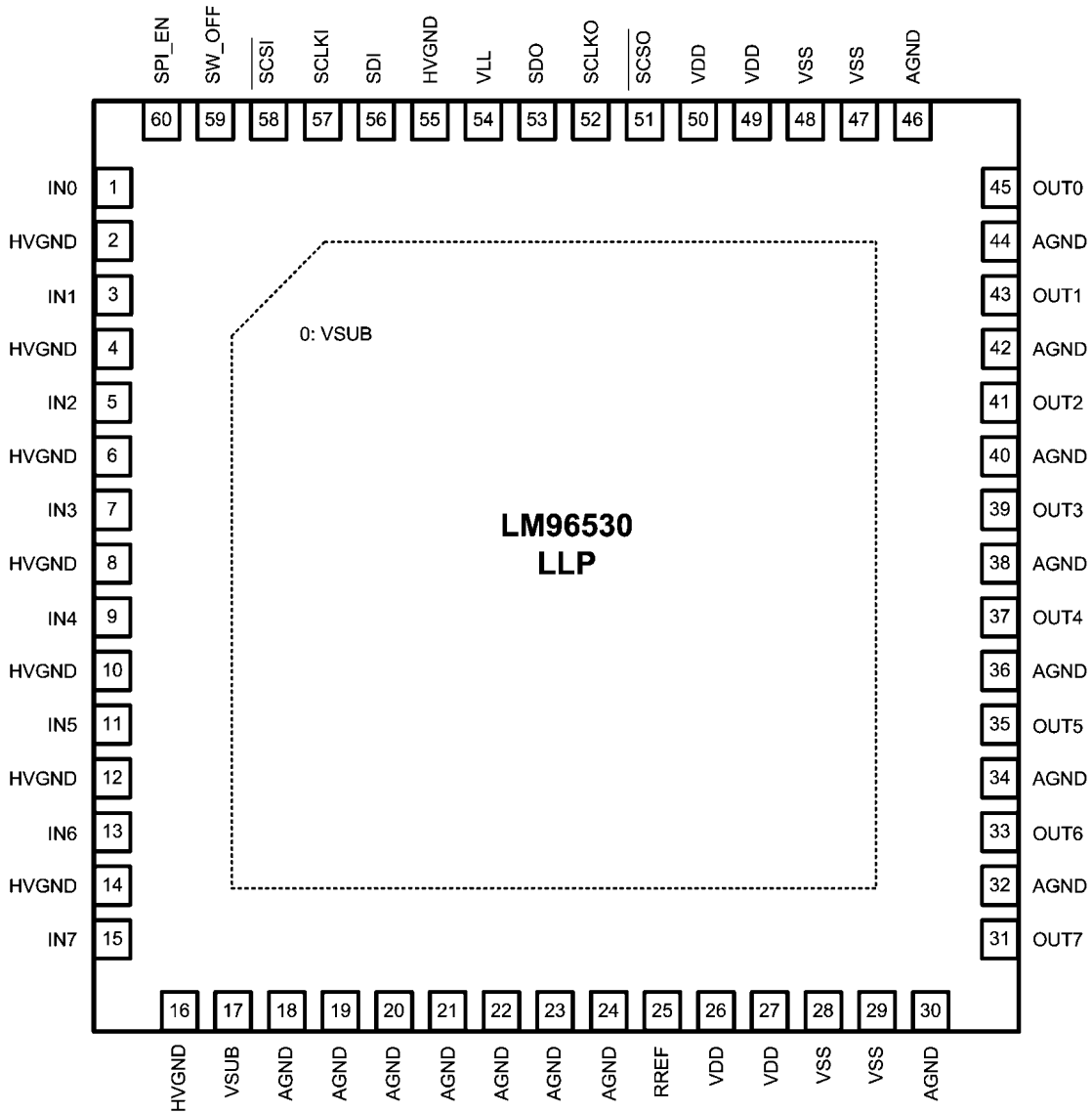

30122001

FIGURE 1. Pin Diagram of LM96530

## Ordering Information

Part Number	Package Type	NSC Package Drawing	Supplied As
LM96530SQ	60 Lead LLP	SQA60A	1000
LM96530SQE			250
LM96530SQX			2000

**TABLE 1. Pin Descriptions**

Pin No.	Name	Type	Function and Connection
1, 3, 5, 7, 9, 11, 13, 15	INn n=0,...,7	Input	High-voltage input
45, 43, 41, 39, 37, 35, 33, 31	OUTn n=0,...	Output	Low-voltage output
25	RREF	Output	External resistor to AGND. Used to set internal current sources. $R_{REF} = 6.25\text{ k}\Omega \rightarrow I_S = 8\text{mA}$ ; $R_{REF} = 12.5\text{ k}\Omega \rightarrow I_S = 4\text{mA}$ ; $R_{REF} = 25\text{ k}\Omega \rightarrow I_S = 2\text{mA}$ ; $R_{REF} = 50\text{ k}\Omega \rightarrow I_S = 1\text{mA}$
59	SW_OFF	Input	1 = Switch all channels OFF 0 = Use SPI™ to control switch
60	SPI_EN	Input	1 = Enable the SPI™ Interface 0 = Disable the SPI™ Interface and presets SPI™ registers for all switches ON.
58	$\overline{\text{SCSI}}$	Input	SPI™ chip select input, 0 = Chip Select
57	SCKI	Input	SPI™ compatible clock input
56	SDI	Input	SPI™ compatible data input
53	SDO	Output	SPI™ compatible data buffered output
52	SCKO	Output	SPI™ compatible clock buffered output
51	$\overline{\text{SCSO}}$	Output	SPI™ chip select buffered output
26, 27, 49, 50	VDD	Power	Positive analog supply voltage (+5V)
28, 29, 47, 48	VSS	Power	Negative analog supply voltage (-5V)
54	VLL	Power	Logic voltage supply (+2.5 to 3.3V)
0, 17	VSUB	Power	Negative high voltage supply (-65V)
2, 4, 6, 8, 10, 12, 14, 16, 55	HVGND	Ground	High voltage reference potential (0V)
All others	AGND	Ground	Analog and logic low voltage reference input, logic ground (0V)

SPI™ is a trademark of Motorola, Inc.

## Absolute Maximum Ratings *(Note 1)*

If Military/Aerospace specified devices are required, please contact the National Semiconductor Sales Office/Distributors for availability and specifications.

Maximum Junction Temperature ( $T_{JMAX}$ )	+150°C
Storage Temperature Range	-40°C to +125°C
Supply Voltage (VDD)	+0.3V to +5.5V
Supply Voltage (VSS)	+0.3V and -5.5V
Supply Voltage (VSUB)	-70V (Must always be most negative voltage)
IO Supply Voltage (VLL)	-0.3V to +3.6V
Voltage at High Voltage Analog Inputs	-70V to 70V
Voltage at Logic Inputs (SCLKI, SDI, SCSI, SW_OFF)	-0.3V to VLL +0.3V

## Operating Ratings

Operation Junction Temperature	0°C to +70°C
VDD, -VSS, Analog Supply	+4.7V to 5.3V
VLL, Logic Supply	+2.4V to 3.5V
High Voltage Analog Inputs	-60V to +60V, VSUB must be most negative supply
VSUB, Substrate bias supply	-50V to -65V

### ESD Tolerance

Human Body Model	2kV
Machine Model	150V
Charge Device Model	750V

**Note 1:** Absolute Maximum Ratings are limits beyond which damage to the device may occur. Operating Ratings are conditions under which operation of the device is guaranteed to be functional, but do not guarantee specific performance limits. For guaranteed specifications and test conditions, see the Electrical Characteristics.

## Functional Description

The LM96530 RX switch provides an 8-channel receive side interface solution for medical ultrasound applications suitable for integration into multi-channel (128 / 256 channel) systems.

Its diode-bridge-based architecture allows high-speed low-distortion channel designs targeting low-power, portable systems. A complete system can be designed using National's companion LM965XX chipset.

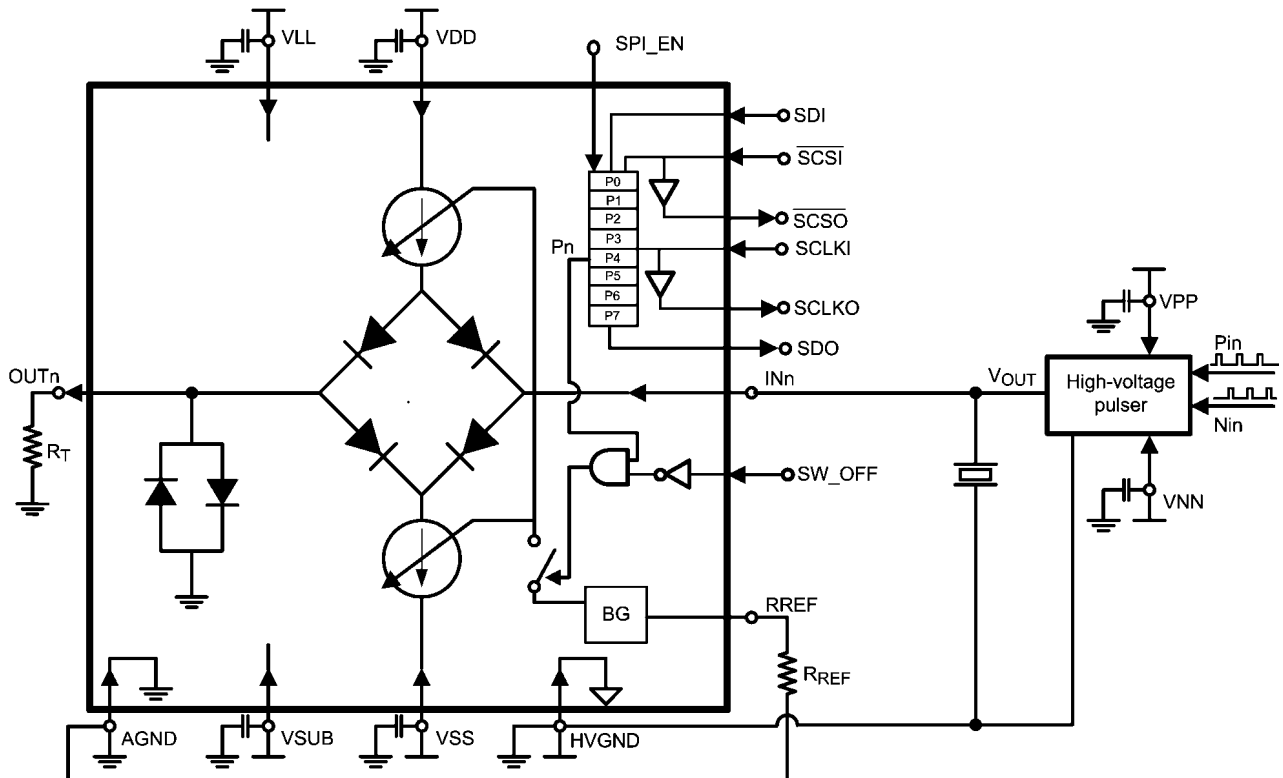

30122002

FIGURE 2. Block Diagram of T/R Channel

A functional block diagram of the IC is shown in . Each RX switch channel on the IC has a high-voltage input that can be directly connected to a transducer driven by a high-voltage pulser, such as the LM96550. The input feeds into a diode bridge with its output being diode-clamped to  $\pm 0.7V$ . The diode bridge bias current is set to 1 mA with  $R_{ref} = 50K\Omega$ . Therefore, the output can be directly connected to a low noise amplifier (LNA) stage which must be protected from the high-voltage signals on the transducer.

The bias current of the bridge is determined by two equally-sized current sources with their current value ranging between 0 and 8mA depending on the external resistor  $R_{ref}$  at the input of the bandgap reference block. While the bias current is the same value for all channels on the IC, each channel can be switched on and off individually with an 8-bit shift register that is programmed via a SPI™ compatible bus.

The on-chip analog circuitry requires dual 5V supplies VDD and VSS, a single logic supply VLL, and a high voltage negative bias, VSUB.

### SERIAL INTERFACE OPERATION

The digital interface is comprised of an 8-bit shift register and a latch. Each bit controls one T/R switch channel, where the MSB bit, i.e., the first bit written (D7) controls channel 7, and the LSB bit (D0) controls channel 0. The three input pins, SDI, SCSi and SCLKI, are all Schmitt Trigger inputs with 0.5V typical hysteresis. The output pins SDO, SCSO, and SCLKO are SPI™ compatible. The serial data input SDI is synchronously read into the shift register on the rising edge of the clock SCLKI. When SCSi changes from low to high, the data in the shift register is transferred to the latch circuit, and output on the parallel data signals P0 through P7 which drive the switched bias current sources for channels  $n=0, \dots, 7$ , respectively. When SCSi changes from high to low, the latch output Pn, and thus the biasing condition, does not change.

### DAISY CHAINING MULTIPLE LM96530 ICs

For connecting multiple T/R switch ICs, the LM965XX SPI™-compatible bus can be daisy-chained up to 16 ICs at 10MHz SCLKI for easy PCB routing. The inputs SDI, SCSi and SCLKI are daisy-chained together with SDO, SCSO and SCLKO. Therefore, the next IC's SDI is connected to the previous IC's SDO. Similarly, the next IC's SCSi is connected to the previous IC's SCSO, and the next IC's SCLKI is connected to the previous IC's SCLKO, as shown in . Daisy-chaining multiple LM96530 devices amounts to one large shift register with the number of bits being equal to 8 times the number of LM96530

ICs. For example, if 3 LM96530 ICs are daisy-chained, one can picture a 24-bit shift register. Thus, the MSB or first bit written on the SDI line (D23) will control channel 7 of the last LM96530, i.e., the IC that is daisy-chained the farthest away from the SPI master. The LSB or last bit written on the SDI line (D0) will control channel 0 of the first LM96530, i.e., the IC that is closest to the SPI master. It is important to note that if only one particular channel of an IC in the daisy-chain requires updating, all of the ICs, i.e., the entire shift register, must be written to.

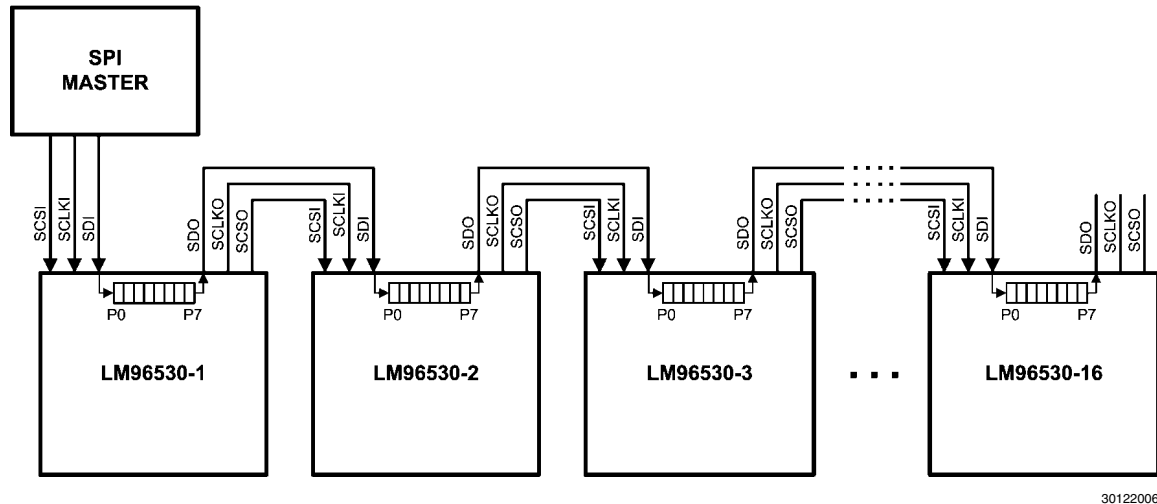

30122006

FIGURE 3. 16 LM96530 Devices Daisy Chained @ SCLKI = 16MHz

### BASIC OPERATION WITHOUT SERIAL INTERFACE COMMUNICATION

To disable the SPI™ compatible interface, connect the pin SPI\_EN to AGND. To reverse bias all 8 channels of the T/R switch, connect the pin, SW\_OFF to VLL. To forward bias all 8 channels of the T/R switch, connect the pin, SW\_OFF to AGND.

### POWER-UP AND POWER-DOWN SEQUENCES

VSUB needs to always be the most negative supply – equal to or more negative than VSS or the most negative transmit pulse at all times. **The power sequence should be to applied to VSUB first, followed by the remaining supplies in any order.**

**Physical Dimensions** inches (millimeters) unless otherwise noted

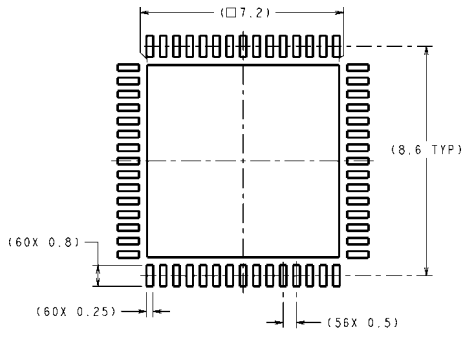

DIMENSIONS ARE IN MILLIMETERS  
DIMENSION IN ( ) FOR REFERENCE ONLY

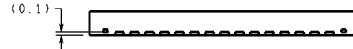

**RECOMMENDED LAND PATTERN**

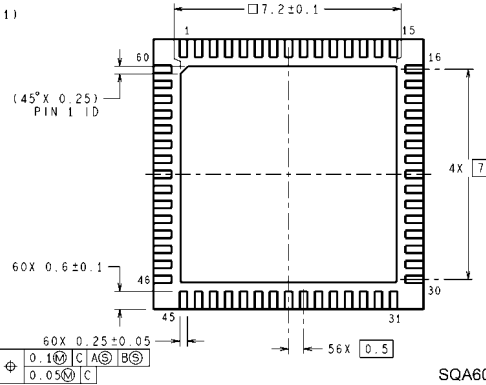
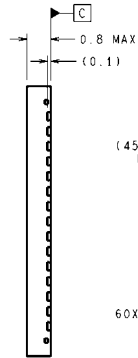
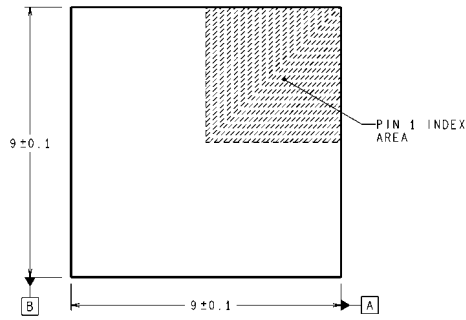

**60-Lead LLP Package**  
**NS Package Number SQA60A**

SQA60A (Rev A)



# Notes

LM196530

## Notes

For more National Semiconductor product information and proven design tools, visit the following Web sites at:  
[www.national.com](http://www.national.com)

Products		Design Support	
Amplifiers	<a href="http://www.national.com/amplifiers">www.national.com/amplifiers</a>	WEBENCH® Tools	<a href="http://www.national.com/webench">www.national.com/webench</a>
Audio	<a href="http://www.national.com/audio">www.national.com/audio</a>	App Notes	<a href="http://www.national.com/appnotes">www.national.com/appnotes</a>
Clock and Timing	<a href="http://www.national.com/timing">www.national.com/timing</a>	Reference Designs	<a href="http://www.national.com/refdesigns">www.national.com/refdesigns</a>
Data Converters	<a href="http://www.national.com/adc">www.national.com/adc</a>	Samples	<a href="http://www.national.com/samples">www.national.com/samples</a>
Interface	<a href="http://www.national.com/interface">www.national.com/interface</a>	Eval Boards	<a href="http://www.national.com/evalboards">www.national.com/evalboards</a>
LVDS	<a href="http://www.national.com/lvds">www.national.com/lvds</a>	Packaging	<a href="http://www.national.com/packaging">www.national.com/packaging</a>
Power Management	<a href="http://www.national.com/power">www.national.com/power</a>	Green Compliance	<a href="http://www.national.com/quality/green">www.national.com/quality/green</a>
Switching Regulators	<a href="http://www.national.com/switchers">www.national.com/switchers</a>	Distributors	<a href="http://www.national.com/contacts">www.national.com/contacts</a>
LDOs	<a href="http://www.national.com/lido">www.national.com/lido</a>	Quality and Reliability	<a href="http://www.national.com/quality">www.national.com/quality</a>
LED Lighting	<a href="http://www.national.com/led">www.national.com/led</a>	Feedback/Support	<a href="http://www.national.com/feedback">www.national.com/feedback</a>
Voltage References	<a href="http://www.national.com/vref">www.national.com/vref</a>	Design Made Easy	<a href="http://www.national.com/easy">www.national.com/easy</a>
PowerWise® Solutions	<a href="http://www.national.com/powerwise">www.national.com/powerwise</a>	Applications & Markets	<a href="http://www.national.com/solutions">www.national.com/solutions</a>
Serial Digital Interface (SDI)	<a href="http://www.national.com/sdi">www.national.com/sdi</a>	Mil/Aero	<a href="http://www.national.com/milaero">www.national.com/milaero</a>
Temperature Sensors	<a href="http://www.national.com/tempensors">www.national.com/tempensors</a>	SolarMagic™	<a href="http://www.national.com/solarmagic">www.national.com/solarmagic</a>
PLL/VCO	<a href="http://www.national.com/wireless">www.national.com/wireless</a>	PowerWise® Design University	<a href="http://www.national.com/training">www.national.com/training</a>

THE CONTENTS OF THIS DOCUMENT ARE PROVIDED IN CONNECTION WITH NATIONAL SEMICONDUCTOR CORPORATION ("NATIONAL") PRODUCTS. NATIONAL MAKES NO REPRESENTATIONS OR WARRANTIES WITH RESPECT TO THE ACCURACY OR COMPLETENESS OF THE CONTENTS OF THIS PUBLICATION AND RESERVES THE RIGHT TO MAKE CHANGES TO SPECIFICATIONS AND PRODUCT DESCRIPTIONS AT ANY TIME WITHOUT NOTICE. NO LICENSE, WHETHER EXPRESS, IMPLIED, ARISING BY ESTOPPEL OR OTHERWISE, TO ANY INTELLECTUAL PROPERTY RIGHTS IS GRANTED BY THIS DOCUMENT.

TESTING AND OTHER QUALITY CONTROLS ARE USED TO THE EXTENT NATIONAL DEEMS NECESSARY TO SUPPORT NATIONAL'S PRODUCT WARRANTY. EXCEPT WHERE MANDATED BY GOVERNMENT REQUIREMENTS, TESTING OF ALL PARAMETERS OF EACH PRODUCT IS NOT NECESSARILY PERFORMED. NATIONAL ASSUMES NO LIABILITY FOR APPLICATIONS ASSISTANCE OR BUYER PRODUCT DESIGN. BUYERS ARE RESPONSIBLE FOR THEIR PRODUCTS AND APPLICATIONS USING NATIONAL COMPONENTS. PRIOR TO USING OR DISTRIBUTING ANY PRODUCTS THAT INCLUDE NATIONAL COMPONENTS, BUYERS SHOULD PROVIDE ADEQUATE DESIGN, TESTING AND OPERATING SAFEGUARDS.

EXCEPT AS PROVIDED IN NATIONAL'S TERMS AND CONDITIONS OF SALE FOR SUCH PRODUCTS, NATIONAL ASSUMES NO LIABILITY WHATSOEVER, AND NATIONAL DISCLAIMS ANY EXPRESS OR IMPLIED WARRANTY RELATING TO THE SALE AND/OR USE OF NATIONAL PRODUCTS INCLUDING LIABILITY OR WARRANTIES RELATING TO FITNESS FOR A PARTICULAR PURPOSE, MERCHANTABILITY, OR INFRINGEMENT OF ANY PATENT, COPYRIGHT OR OTHER INTELLECTUAL PROPERTY RIGHT.

#### LIFE SUPPORT POLICY

**NATIONAL'S PRODUCTS ARE NOT AUTHORIZED FOR USE AS CRITICAL COMPONENTS IN LIFE SUPPORT DEVICES OR SYSTEMS WITHOUT THE EXPRESS PRIOR WRITTEN APPROVAL OF THE CHIEF EXECUTIVE OFFICER AND GENERAL COUNSEL OF NATIONAL SEMICONDUCTOR CORPORATION.** As used herein:

Life support devices or systems are devices which (a) are intended for surgical implant into the body, or (b) support or sustain life and whose failure to perform when properly used in accordance with instructions for use provided in the labeling can be reasonably expected to result in a significant injury to the user. A critical component is any component in a life support device or system whose failure to perform can be reasonably expected to cause the failure of the life support device or system or to affect its safety or effectiveness.

National Semiconductor and the National Semiconductor logo are registered trademarks of National Semiconductor Corporation. All other brand or product names may be trademarks or registered trademarks of their respective holders.

Copyright© 2011 National Semiconductor Corporation

For the most current product information visit us at [www.national.com](http://www.national.com)



**National Semiconductor  
Americas Technical  
Support Center**  
Email: [support@nsc.com](mailto:support@nsc.com)  
Tel: 1-800-272-9959

**National Semiconductor Europe  
Technical Support Center**  
Email: [europe.support@nsc.com](mailto:europe.support@nsc.com)

**National Semiconductor Asia  
Pacific Technical Support Center**  
Email: [ap.support@nsc.com](mailto:ap.support@nsc.com)

**National Semiconductor Japan  
Technical Support Center**  
Email: [jpn.feedback@nsc.com](mailto:jpn.feedback@nsc.com)