

# LM809/LM810

## 3-Pin Microprocessor Reset Circuits

### General Description

The LM809/810 microprocessor supervisory circuits can be used to monitor the power supplies in microprocessor and digital systems. They provide a reset to the microprocessor during power-up, power-down and brown-out conditions.

The function of the LM809/810 is to monitor the  $V_{CC}$  supply voltage, and assert a reset signal whenever this voltage declines below the factory-programmed reset threshold. The reset signal remains asserted for 240ms after  $V_{CC}$  rises above the threshold. The LM809 has an active-low  $\overline{\text{RESET}}$  output, while the LM810 has an active-high RESET output.

Seven standard reset voltage options are available, suitable for monitoring 5V, 3.3V, and 3V supply voltages.

With a low supply current of only 15 $\mu\text{A}$ , the LM809/810 are ideal for use in portable equipment. The LM809/LM810 are available in the 3-pin SOT23 package and in the 6-Lead LLP package.

### Features

- Precise monitoring of 3V, 3.3V, and 5V supply voltages
- Superior upgrade to MAX809/810
- Fully specified over temperature
- 140ms min. Power-On Reset pulse width, 240ms typical
  - Active-low  $\overline{\text{RESET}}$  Output (LM809)
  - Active-high RESET Output (LM810)
- Guaranteed RESET Output valid for  $V_{CC} \geq 1\text{V}$
- Low Supply Current, 15 $\mu\text{A}$  typ.
- Power supply transient immunity

### Applications

- Microprocessor Systems
- Computers
- Controllers
- Intelligent Instruments
- Portable/Battery-Powered Equipment
- Automotive

### Typical Application Circuit

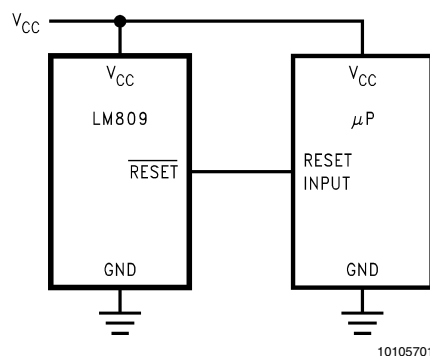

### Connection Diagrams

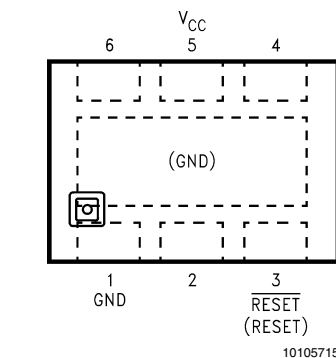
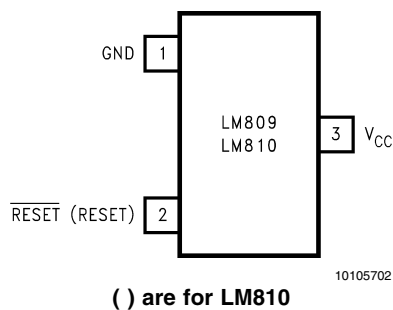

## Ordering Information

Reset Threshold (V)	LM809 Supplied as 1000 units, tape & reel	LM809 Supplied as 3000 units, tape & reel	Package Top Mark	Package Type	NSC Package
4.63	LM809M3-4.63	LM809M3X-4.63	S8B	SOT23-3	M03B
4.38	LM809M3-4.38	LM809M3X-4.38	S7B		
4.00	LM809M3-4.00	LM809M3X-4.00	S6B		
3.08	LM809M3-3.08	LM809M3X-3.08	S5B		
2.93	LM809M3-2.93	LM809M3X-2.93	S4B		
2.63	LM809M3-2.63	LM809M3X-2.63	S3B		
2.45	LM809M3-2.45	LM809M3X-2.45	SFB		
Reset Threshold (V)	LM810 Supplied as 1000 units, tape & reel	LM810 Supplied as 3000 units, tape & reel	Package Top Mark	Package Type	NSC Package
4.63	LM810M3-4.63	LM810M3X-4.63	SEB	SOT23-3	M03B
4.38	LM810M3-4.38	LM810M3X-4.38	SDB		
4.00	LM810M3-4.00	LM810M3X-4.00	SCB		
3.08	LM810M3-3.08	LM810M3X-3.08	SBB		
2.93	LM810M3-2.93	LM810M3X-2.93	SAB		
2.63	LM810M3-2.63	LM810M3X-2.63	S9B		
Reset Threshold (V)	LM809 Supplied as 1000 units, tape & reel	LM809 Supplied as 4500 units, tape & reel	Package Top Mark	Package Type	NSC Package
2.63	LM809LD-2.63	LM809LDX-2.63	S13	LLP-6	LDB06A

Custom voltages and improved accuracies are available, subject to minimum orders. Contact your local National Semiconductor Sales Office for information.

## Pin Descriptions

PIN		NAME	FUNCTION
(LLP)	SOT-23		
1	1	GND	Ground reference
3	2	RESE $\bar{T}$ (LM809)	Active-low output. RESE $\bar{T}$ remains low while $V_{CC}$ is below the reset threshold, and for 240ms after $V_{CC}$ rises above the reset threshold.
		RESET (LM810)	Active-high output. RESET remains high while $V_{CC}$ is below the reset threshold, and for 240ms after $V_{CC}$ rises above the reset threshold.
5	3	$V_{CC}$	Supply Voltage (+5V, +3.3V, or +3.0V)

**Absolute Maximum Ratings** (Note 1)

If Military/Aerospace specified devices are required, please contact the National Semiconductor Sales Office/Distributors for availability and specifications.

$V_{CC}$	-0.3V to 6.0V
RESET, $\overline{\text{RESET}}$	-0.3V to ( $V_{CC} + 0.3V$ )
Input Current, $V_{CC}$ Pin	20mA
Output Current, RESET, $\overline{\text{RESET}}$ Pin	20mA
Rate of Rise, $V_{CC}$	100V/ $\mu$ s
ESD Rating (Note 2)	2kV

Continuous Power Dissipation (Note 4)	320mW
$\theta_{JA}$ :	
LLP-6	152°C/W
SOT23-3	326°C/W
Ambient Temperature Range	-40°C to +105°C
Maximum Junction Temperature	125°C
Storage Temperature Range	-65°C to +160°C
Lead Temperature (soldering, 10sec)	+300°C

**Electrical Characteristics**

$V_{CC}$  = full range,  $T_A$  = -40°C to +105°C, unless otherwise noted. Typical values are at  $T_A$  = +25°C,  $V_{CC}$  = 5V for 4.63/4.38/4.00 versions,  $V_{CC}$  = 3.3V for 3.08/2.93 versions, and  $V_{CC}$  = 3V for 2.63/2.45 version (Note 3).

Symbol	Parameter	Conditions	Min	Typ	Max	Units			
	$V_{CC}$ Range	$T_A = 0^\circ\text{C to } +70^\circ\text{C}$	1.0		5.5	V			
		$T_A = -40^\circ\text{C to } +105^\circ\text{C}$	1.2		5.5				
$I_{CC}$	Supply Current	$T_A = -40^\circ\text{C to } +85^\circ\text{C}$	$V_{CC} < 5.5V$ , LM8_ _ -4.63/4.38/4.00	18	60	$\mu$ A			
			$V_{CC} < 3.6V$ , LM8_ _ -3.08/2.93/2.63/2.45	15	50				
		$T_A = +85^\circ\text{C to } +105^\circ\text{C}$	$V_{CC} < 5.5V$ , LM8_ _ -4.63/4.38/4.00		100				
			$V_{CC} < 3.6V$ , LM8_ _ -3.08/2.93/2.63/2.45		100				
$V_{TH}$	Reset Threshold (Note 5)	LM8_ _ -4.63	$T_A = +25^\circ\text{C}$	4.56	4.63	4.70	V		
			$T_A = -40^\circ\text{C to } +85^\circ\text{C}$	4.50		4.75			
			$T_A = +85^\circ\text{C to } +105^\circ\text{C}$	4.40		4.86			
		LM8_ _ -4.38	$T_A = +25^\circ\text{C}$	4.31	4.38	4.45			
			$T_A = -40^\circ\text{C to } +85^\circ\text{C}$	4.25		4.50			
			$T_A = +85^\circ\text{C to } +105^\circ\text{C}$	4.16		4.56			
		LM8_ _ -4.00	$T_A = +25^\circ\text{C}$	3.93	4.00	4.06			
			$T_A = -40^\circ\text{C to } +85^\circ\text{C}$	3.89		4.10			
			$T_A = +85^\circ\text{C to } +105^\circ\text{C}$	3.80		4.20			
		LM8_ _ -3.08	$T_A = +25^\circ\text{C}$	3.04	3.08	3.11			
			$T_A = -40^\circ\text{C to } +85^\circ\text{C}$	3.00		3.15			
			$T_A = +85^\circ\text{C to } +105^\circ\text{C}$	2.92		3.23			
		LM8_ _ -2.93	$T_A = +25^\circ\text{C}$	2.89	2.93	2.96			
			$T_A = -40^\circ\text{C to } +85^\circ\text{C}$	2.85		3.00			
			$T_A = +85^\circ\text{C to } +105^\circ\text{C}$	2.78		3.08			
		LM8_ _ -2.63	$T_A = +25^\circ\text{C}$	2.59	2.63	2.66			
			$T_A = -40^\circ\text{C to } +85^\circ\text{C}$	2.55		2.70			
			$T_A = +85^\circ\text{C to } +105^\circ\text{C}$	2.50		2.76			
		LM8_ _ -2.45	$T_A = +25^\circ\text{C}$	2.41	2.45	2.49			
			$T_A = -40^\circ\text{C to } +85^\circ\text{C}$	2.38		2.52			
			$T_A = +85^\circ\text{C to } +105^\circ\text{C}$	2.33		2.57			
			Reset Threshold Temperature Coefficient			30			ppm/ $^\circ\text{C}$
			$V_{CC}$ to Reset Delay (Note 5)	$V_{CC} = V_{TH}$ to ( $V_{TH} - 100\text{mV}$ )		20			$\mu$ s
			Reset Active Timeout Period	$T_A = -40^\circ\text{C to } +85^\circ\text{C}$	140	240		560	ms
$T_A = +85^\circ\text{C to } +105^\circ\text{C}$	100				840				

## Electrical Characteristics (Continued)

$V_{CC}$  = full range,  $T_A$  =  $-40^{\circ}\text{C}$  to  $+105^{\circ}\text{C}$ , unless otherwise noted. Typical values are at  $T_A$  =  $+25^{\circ}\text{C}$ ,  $V_{CC}$  = 5V for 4.63/4.38/4.00 versions,  $V_{CC}$  = 3.3V for 3.08/2.93 versions, and  $V_{CC}$  = 3V for 2.63/2.45 version (Note 3).

Symbol	Parameter	Conditions	Min	Typ	Max	Units
$V_{OL}$	$\overline{\text{RESET}}$ Output Voltage Low (LM809)	$V_{CC} = V_{TH} \text{ min}$ , $I_{SINK} = 1.2\text{mA}$ , LM809-2.45/2.63/2.93/3.08			0.3	V
		$V_{CC} = V_{TH} \text{ min}$ , $I_{SINK} = 3.2\text{mA}$ , LM809-4.63/4.38/4.00			0.4	
		$V_{CC} > 1.0\text{V}$ , $I_{SINK} = 50\mu\text{A}$			0.3	
$V_{OH}$	$\overline{\text{RESET}}$ Output Voltage High (LM809)	$V_{CC} > V_{TH} \text{ max}$ , $I_{SOURCE} = 500\mu\text{A}$ , LM809-2.45/2.63/2.93/3.08	$0.8V_{CC}$			V
		$V_{CC} > V_{TH} \text{ max}$ , $I_{SOURCE} = 800\mu\text{A}$ , LM809-4.63/4.38/4.00	$V_{CC}-1.5$			
$V_{OL}$	RESET Output Voltage Low (LM810)	$V_{CC} = V_{TH} \text{ max}$ , $I_{SINK} = 1.2\text{mA}$ , LM810-2.63/2.93/3.08			0.3	V
		$V_{CC} = V_{TH} \text{ max}$ , $I_{SINK} = 3.2\text{mA}$ , LM810-4.63/4.38/4.00			0.4	
$V_{OH}$	RESET Output Voltage High (LM810)	$1.8\text{V} < V_{CC} < V_{TH} \text{ min}$ , $I_{SOURCE} = 150\mu\text{A}$	$0.8V_{CC}$			V

**Note 1:** Absolute Maximum Ratings are limits beyond which damage to the device may occur. Operating Ratings are conditions under which the device operates correctly. Operating ratings do not imply guaranteed performance limits. For guaranteed performance limits and associated test conditions, see the Electrical Characteristics.

**Note 2:** The human body model is a 100pF capacitor discharged through a 1.5k $\Omega$  resistor into each pin.

**Note 3:** Production testing done at  $T_A = +25^{\circ}\text{C}$ , over temperature limits guaranteed by design only.

**Note 4:** At elevated temperatures, devices must be derated based on package thermal resistance. The device in the SOT23-3 package must be derated at 4mW/ $^{\circ}\text{C}$  at ambient temperatures above 70 $^{\circ}\text{C}$ . The device has internal thermal protection.

**Note 5:**  $\overline{\text{RESET}}$  Output for LM809, RESET output for LM810.

# Typical Performance Characteristics

**Supply Current vs Temperature  
(No Load, LM8\_\_-2.63/2.93/3.08)**

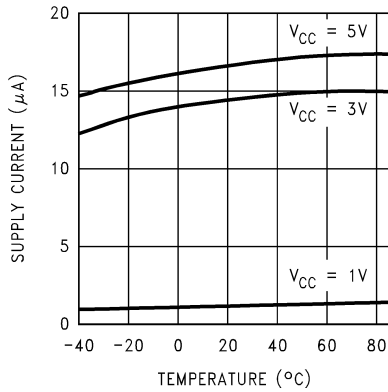

10105703

**Power-Down Reset Delay vs Temperature  
(LM8\_\_-4.63/4.38)**

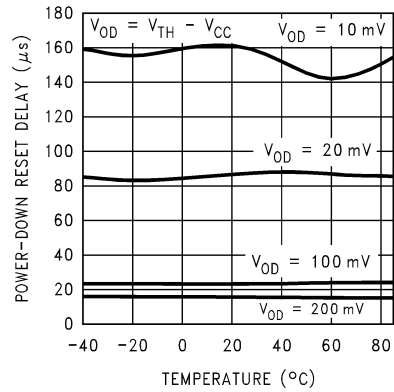

10105706

**Supply Current vs Temperature  
(No Load, LM8\_\_-4.63/4.38)**

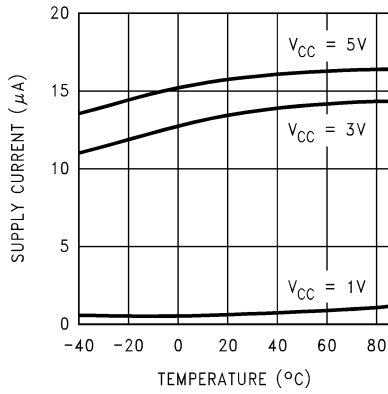

10105704

**Power-Up Reset Timeout vs Temperature**

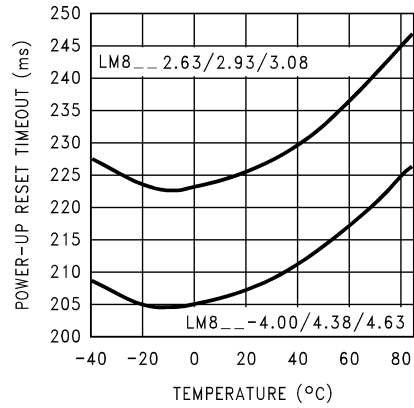

10105707

**Power-Down Reset Delay vs Temp  
(LM8\_\_-2.63/2.93/3.08)**

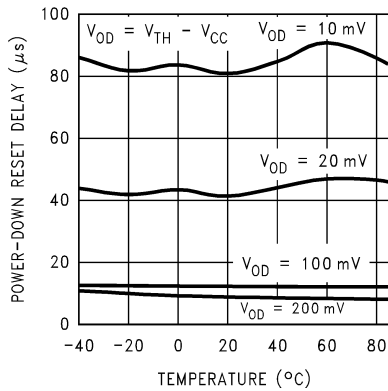

10105705

**Normalized Reset Threshold vs Temperature**

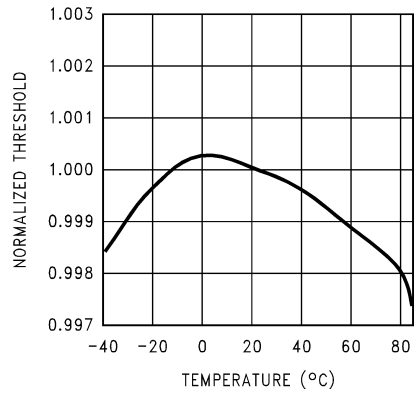

10105708

## Applications Information

### Benefits of Precision Reset Thresholds

A microprocessor supply supervisor must provide a reset output within a predictable range of the supply voltage. A common threshold range is between 5% and 10% below the nominal supply voltage. The 4.63V and 3.08V options of the LM809/810 use highly accurate circuitry to ensure that the reset threshold occurs only within this range (for 5V and 3.3V supplies). The other voltage options have the same tight tolerance to ensure a reset signal for other narrow monitor ranges. See *Table 1* for examples of how the standard reset thresholds apply to 3V, 3.3V, and 5V nominal supply voltages.

**TABLE 1. Reset Thresholds Related to Common Supply Voltages**

Reset Threshold	3.0V	3.3V	5.0V
4.63 ± 3%			90 - 95%
4.38 ± 3%			85 - 90%
4.00 ± 3%			78 - 82%
3.08 ± 3%		90 - 95%	
2.93 ± 3%		86 - 90%	
2.63 ± 3%	85 - 90%	77 - 81%	
2.45 ± 3%	79 - 84%	72 - 76%	

### Ensuring a Valid Reset Output Down to $V_{CC} = 0V$

When  $V_{CC}$  falls below 1V, the LM809  $\overline{\text{RESET}}$  output no longer sinks current. A high-impedance CMOS logic input connected to  $\overline{\text{RESET}}$  can therefore drift to undetermined voltages. To prevent this situation, a 100k $\Omega$  resistor should be connected from the  $\overline{\text{RESET}}$  output to ground, as shown in *Figure 1*.

A 100k $\Omega$  pull-up resistor to  $V_{CC}$  is also recommended for the LM810, if  $\overline{\text{RESET}}$  is required to remain valid for  $V_{CC} < 1V$ .

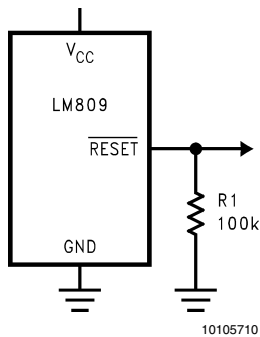
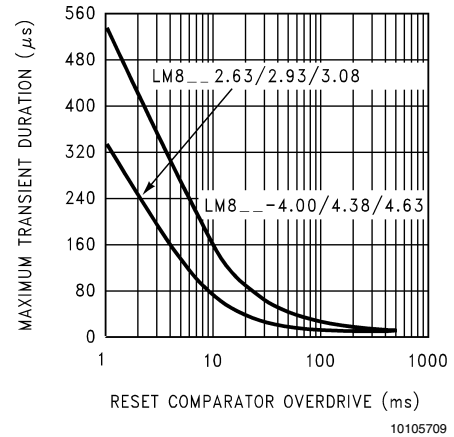

**FIGURE 1.  $\overline{\text{RESET}}$  Valid to  $V_{CC} = \text{Ground}$  Circuit**

### Negative-Going $V_{CC}$ Transients

The LM809/810 are relatively immune to short negative-going transients or glitches on  $V_{CC}$ . *Figure 2* shows the maximum pulse width a negative-going  $V_{CC}$  transient can have without causing a reset pulse. In general, as the magnitude of the transient increases, going further below the threshold, the maximum allowable pulse width decreases.

Typically, for the 4.63V and 4.38V version of the LM809/810, a  $V_{CC}$  transient that goes 100mV below the reset threshold and lasts 20 $\mu\text{s}$  or less will not cause a reset pulse. A 0.1  $\mu\text{F}$  bypass capacitor mounted as close as possible to the  $V_{CC}$  pin will provide additional transient rejection.



**FIGURE 2. Maximum Transient Duration without Causing a Reset Pulse vs. Reset Comparator Overdrive**

### Interfacing to $\mu\text{Ps}$ with Bidirectional Reset Pins

Microprocessors with bidirectional reset pins, such as the Motorola 68HC11 series, can be connected to the LM809  $\overline{\text{RESET}}$  output. To ensure a correct output on the LM809 even when the microprocessor reset pin is in the opposite state, connect a 4.7k $\Omega$  resistor between the LM809  $\overline{\text{RESET}}$  output and the  $\mu\text{P}$  reset pin, as shown in *Figure 3*. Buffer the LM809  $\overline{\text{RESET}}$  output to other system components.

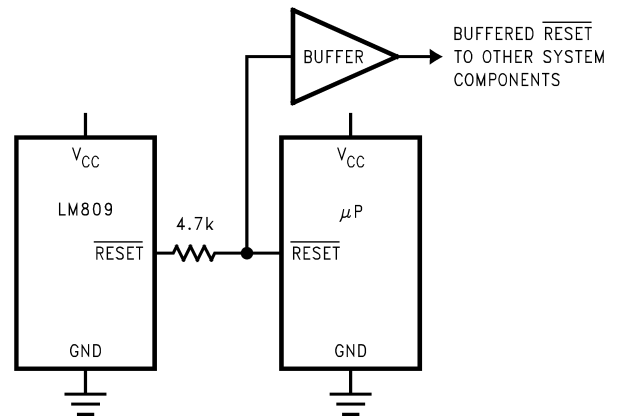
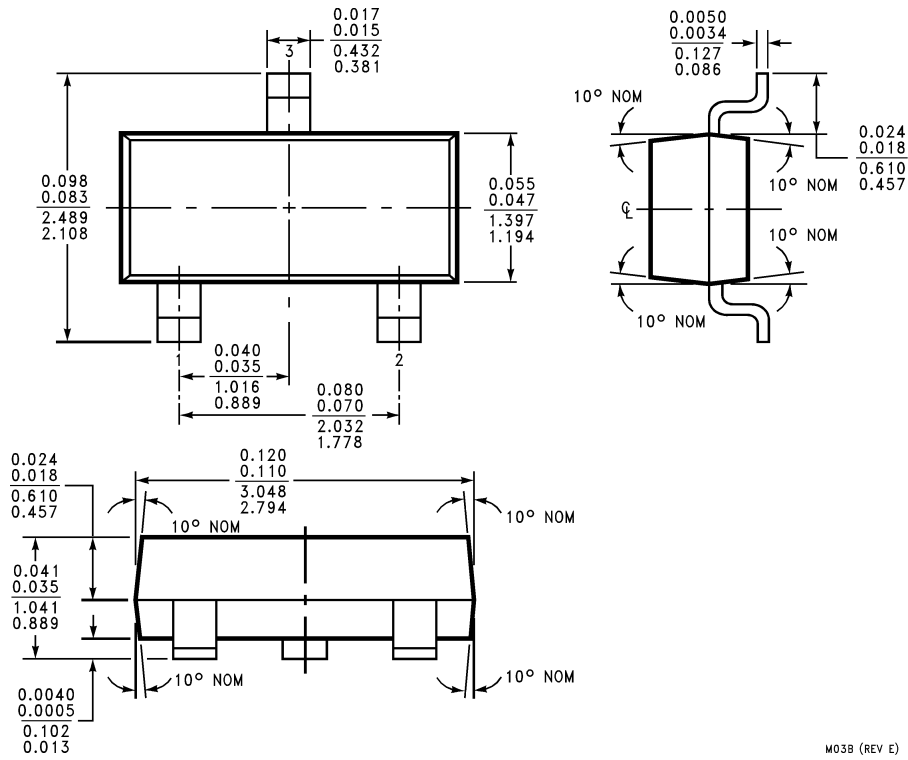

**FIGURE 3. Interfacing to Microprocessors with Bidirectional Reset I/O**

### LLP Mounting

The LLP package requires special mounting techniques which are detailed in National Semiconductor Application Note AN-1187. Referring to the section PCB Design Recommendations, it should be noted that the pad style which should be used with the LLP package is the NSMD (non-solder mask defined) type.

**Physical Dimensions** inches (millimeters) unless otherwise noted



**3-Lead SOT23-3**  
**For Ordering, refer to Ordering Information table**  
**NS Package Number M03B**

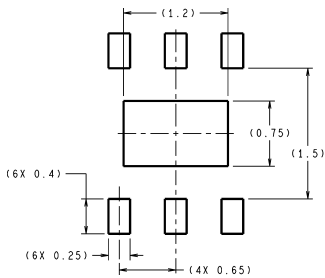

**RECOMMENDED LAND PATTERN**  
 1:1 RATIO WITH PKG SOLDER PADS

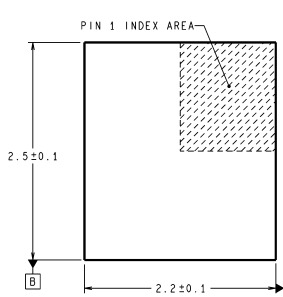

DIMENSIONS ARE IN MILLIMETERS

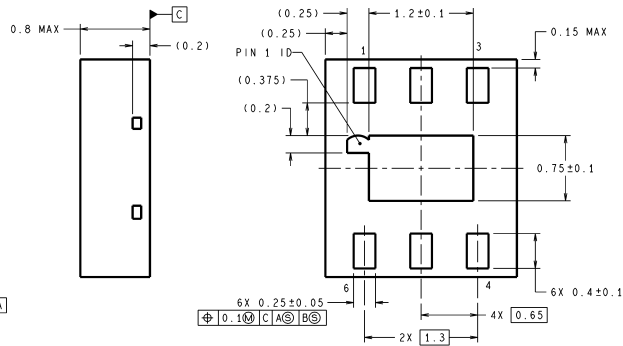

LDB06A (Rev A)

**6-Lead LLP (NLDBB006)**  
**For Ordering, refer to Ordering Information table**  
**NS Package Number LDB06A**

## Notes

**LIFE SUPPORT POLICY**

NATIONAL'S PRODUCTS ARE NOT AUTHORIZED FOR USE AS CRITICAL COMPONENTS IN LIFE SUPPORT DEVICES OR SYSTEMS WITHOUT THE EXPRESS WRITTEN APPROVAL OF THE PRESIDENT AND GENERAL COUNSEL OF NATIONAL SEMICONDUCTOR CORPORATION. As used herein:

1. Life support devices or systems are devices or systems which, (a) are intended for surgical implant into the body, or (b) support or sustain life, and whose failure to perform when properly used in accordance with instructions for use provided in the labeling, can be reasonably expected to result in a significant injury to the user.
2. A critical component is any component of a life support device or system whose failure to perform can be reasonably expected to cause the failure of the life support device or system, or to affect its safety or effectiveness.



**National Semiconductor Corporation**  
Americas  
Email: support@nsc.com

www.national.com

**National Semiconductor Europe**

Fax: +49 (0) 180-530 85 86  
Email: europe.support@nsc.com  
Deutsch Tel: +49 (0) 69 9508 6208  
English Tel: +44 (0) 870 24 0 2171  
Français Tel: +33 (0) 1 41 91 8790

**National Semiconductor Asia Pacific Customer Response Group**

Tel: 65-2544466  
Fax: 65-2504466  
Email: ap.support@nsc.com

**National Semiconductor Japan Ltd.**

Tel: 81-3-5639-7560  
Fax: 81-3-5639-7507