

LM7341 Rail-to-Rail Input/Output ±15V, 4.6 MHz GBW, Operational Amplifier in SOT-23 Package

General Description

The LM7341 is a rail-to-rail input and output amplifier in a small SOT-23 package with a wide supply voltage and temperature range. The LM7341 has a 4.6 MHz gain bandwidth and a 1.9 volt per microsecond slew rate, and draws 0.75 mA of supply current at no load.

The LM7341 is tested at -40°C, 125°C and 25°C with modern automatic test equipment. Detailed performance specifications at 2.7V, ±5V, and ±15V and over a wide temperature range make the LM7341 a good choice for automotive, industrial, and other demanding applications.

Greater than rail-to-rail input common mode range with a minimum 76 dB of common mode rejection at ±15V makes the LM7341 a good choice for both high and low side sensing applications.

LM7341 performance is consistent over a wide voltage range, making the part useful for applications where the supply voltage can change, such as automotive electrical systems and battery powered electronics.

The LM7341 uses a small SOT23-5 package, which takes up little board space, and can be placed near signal sources to reduce noise pickup.

Features

($V_S = \pm 15V$, $T_A = 25^\circ C$, typical values.)

- Tiny 5-pin SOT-23 package saves space
- Greater than rail-to-rail input CMVR -15.3V to 15.3V
- Rail-to-rail output swing -14.84V to 14.86V
- Supply current 0.7 mA
- Gain bandwidth 4.6 MHz
- Slew Rate 1.9 V/ μ s
- Wide supply range 2.7V to 32V
- High power supply rejection ratio 106 dB
- High common mode rejection ratio 115 dB
- Excellent gain 106 dB
- Temperature range -40°C to 125°C
- Tested at -40°C, 125°C and 25°C at 2.7V, ±5V and ±15V

Applications

- Automotive
- Industrial robotics
- Sensor output buffers
- Multiple voltage power supplies
- Reverse biasing of photodiodes
- Low current optocouplers
- High side sensing
- Comparator
- Battery chargers
- Test point output buffers
- Below ground current sensing

Typical Performance Characteristics

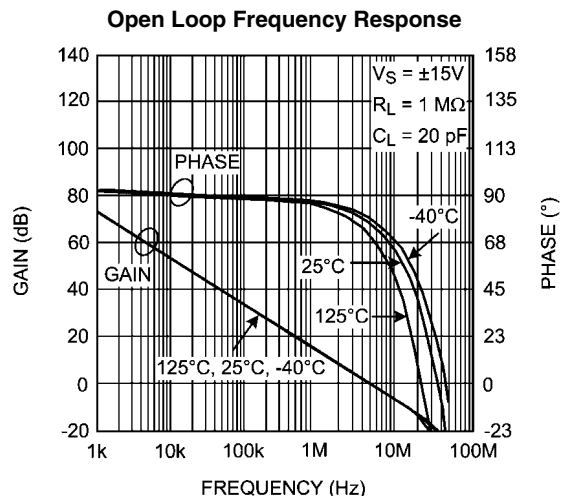
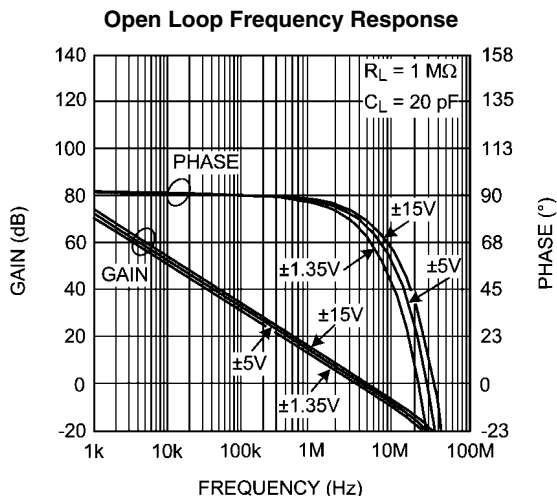

Absolute Maximum Ratings (Note 1)

If Military/Aerospace specified devices are required, please contact the National Semiconductor Sales Office/ Distributors for availability and specifications.

ESD Tolerance (Note 2)	
Human Body Model	2000V
Machine Model	200V
Charge-Device Model	1000V
V_{IN} Differential	$\pm 15V$
Voltage at Input/Output Pin	$(V^+) + 0.3V, (V^-) - 0.3V$
Supply Voltage ($V_S = V^+ - V^-$)	35V
Input Current	± 10 mA
Output Current (Note 3)	± 20 mA

Power Supply Current	25 mA
Soldering Information	
Infrared or Convection (20 sec)	235°C
Wave Soldering Lead Temp. (10 sec.)	260°C
Storage Temperature Range	-65°C to 150°C
Junction Temperature (Note 4)	150°C

Operating Ratings (Note 1)

Supply Voltage ($V_S = V^+ - V^-$)	2.5V to 32V
Temperature Range (Note 4)	-40°C to 125°C
Package Thermal Resistance (θ_{JA})	
5-Pin SOT-23	325°C/W

2.7V Electrical Characteristics

Unless otherwise specified, all limits guaranteed for $T_A = 25^\circ\text{C}$, $V^+ = 2.7V$, $V^- = 0V$, $V_{CM} = 0.5V$, $V_{OUT} = 1.35V$ and $R_L > 1$ M Ω to 1.35V. **Boldface** limits apply at the temperature extremes

Symbol	Parameter	Conditions	Min (Note 6)	Typ (Note 5)	Max (Note 6)	Units
V_{OS}	Input Offset Voltage	$V_{CM} = 0.5V$ and $V_{CM} = 2.2V$	-4 -5	± 0.2	+4 +5	mV
TCV_{OS}	Input Offset Voltage Temperature Drift			± 2		$\mu\text{V}/^\circ\text{C}$
I_B	Input Bias Current	$V_{CM} = 0.5V$	-180 -200	-90		nA
		$V_{CM} = 2.2V$		30	60 70	
I_{OS}	Input Offset Current	$V_{CM} = 0.5V$ and $V_{CM} = 2.2V$		1	40 50	nA
CMRR	Common Mode Rejection Ratio	$0V \leq V_{CM} \leq 1.0V$	82 80	106		dB
		$0V \leq V_{CM} \leq 2.7V$	62 60	80		
PSRR	Power Supply Rejection Ratio	$2.7V \leq V_S \leq 30V$ $V_{CM} = 0.5V$	86 84	106		dB
CMVR	Common Mode Voltage Range	CMRR > 60 dB		-0.3 2.7	0.0	V
A_{VOL}	Open Loop Voltage Gain	$0.5V \leq V_O \leq 2.2V$ $R_L = 10$ k Ω to 1.35V	12 8	65		V/mV
V_{OUT}	Output Voltage Swing High	$R_L = 10$ k Ω to 1.35V $V_{ID} = 100$ mV		50	120 150	mV from either rail
		$R_L = 2$ k Ω to 1.35V $V_{ID} = 100$ mV		95	150 200	
	Output Voltage Swing Low	$R_L = 10$ k Ω to 1.35V $V_{ID} = -100$ mV		55	120 150	
		$R_L = 2$ k Ω to 1.35V $V_{ID} = -100$ mV		100	150 200	
I_{OUT}	Output Current	Sourcing, $V_{OUT} = 0V$ $V_{ID} = 200$ mV	6 4	12		mA
		Sinking, $V_{OUT} = 0V$ $V_{ID} = -200$ mV	5 3	10		
I_S	Supply Current	$V_{CM} = 0.5V$ and $V_{CM} = 2.2V$		0.6	0.9 1.0	mA
SR	Slew Rate	$\pm 1V$ Step		1.5		V/ μs

Symbol	Parameter	Conditions	Min (Note 6)	Typ (Note 5)	Max (Note 6)	Units
GBW	Gain Bandwidth	$f = 100 \text{ kHz}$, $R_L = 100 \text{ k}\Omega$		3.6		MHz
e_n	Input Referred Voltage Noise Density	$f = 1 \text{ kHz}$		35		$\text{nV}/\sqrt{\text{Hz}}$
i_n	Input Referred Voltage Noise Density	$f = 1 \text{ kHz}$		0.28		$\mu\text{A}/\sqrt{\text{Hz}}$
THD+N	Total Harmonic Distortion + Noise	$f = 10 \text{ kHz}$		-66		dB
t_{PD}	Propagation Delay	Overdrive = 50 mV (Note 7)		4		μs
		Overdrive = 1V (Note 7)		3		
t_r	Rise Time	20% to 80% (Note 7)		1		μs
t_f	Fall Time	80% to 20% (Note 7)		1		μs

±5V Electrical Characteristics

Unless otherwise specified, all limits guaranteed for $T_A = 25^\circ\text{C}$, $V^+ = +5\text{V}$, $V^- = -5\text{V}$, $V_{CM} = V_{OUT} = 0\text{V}$ and $R_L > 1 \text{ M}\Omega$ to 0V .

Boldface limits apply at the temperature extremes.

Symbol	Parameter	Conditions	Min (Note 6)	Typ (Note 5)	Max (Note 6)	Units
V_{OS}	Input Offset Voltage	$V_{CM} = -4.5\text{V}$ and $V_{CM} = 4.5\text{V}$	-4 -5	± 0.2	+4 +5	mV
TCV_{OS}	Input Offset Voltage Temperature Drift			± 2		$\mu\text{V}/^\circ\text{C}$
I_B	Input Bias Current	$V_{CM} = -4.5\text{V}$	-200 -250	-95		nA
		$V_{CM} = 4.5\text{V}$		35	70 80	
I_{OS}	Input Offset Current	$V_{CM} = -4.5\text{V}$ and $V_{CM} = 4.5\text{V}$		1	40 50	nA
CMRR	Common Mode Rejection Ratio	$-5\text{V} \leq V_{CM} \leq 3\text{V}$	84 82	112		dB
		$-5\text{V} \leq V_{CM} \leq 5\text{V}$	72 70	92		
PSRR	Power Supply Rejection Ratio	$2.7\text{V} \leq V_S \leq 30\text{V}$, $V_{CM} = -4.5\text{V}$	86 84	106		dB
CMVR	Common Mode Voltage Range	CMRR $\geq 65 \text{ dB}$		-5.3	-5.0	V
			5.0	5.3		
A_{VOL}	Open Loop Voltage Gain	$-4\text{V} \leq V_O \leq 4\text{V}$ $R_L = 10 \text{ k}\Omega$ to 0V	20 12	110		V/mV
V_{OUT}	Output Voltage Swing High	$R_L = 10 \text{ k}\Omega$ to 0V , $V_{ID} = 100 \text{ mV}$		80	150 200	mV from either rail
		$R_L = 2 \text{ k}\Omega$ to 0V , $V_{ID} = 100 \text{ mV}$		170	300 400	
	Output Voltage Swing Low	$R_L = 10 \text{ k}\Omega$ to 0V $V_{ID} = -100 \text{ mV}$		90	150 200	
		$R_L = 2 \text{ k}\Omega$ to 0V $V_{ID} = -100 \text{ mV}$		210	300 400	
I_{OUT}	Output Current	Sourcing, $V_{OUT} = -5\text{V}$ $V_{ID} = 200 \text{ mV}$	6 4	11		mA
		Sinking, $V_{OUT} = 5\text{V}$ $V_{ID} = -200 \text{ mV}$	6 4	12		
I_S	Supply Current	$V_{CM} = -4.5\text{V}$ and $V_{CM} = 4.5\text{V}$		0.65	1.0 1.1	mA
SR	Slew Rate	$\pm 4\text{V}$ Step		1.7		V/ μs
GBW	Gain Bandwidth	$f = 100 \text{ kHz}$, $R_L = 100 \text{ k}\Omega$		4.0		MHz

Symbol	Parameter	Conditions	Min (Note 6)	Typ (Note 5)	Max (Note 6)	Units
e_n	Input Referred Voltage Noise Density	$f = 1 \text{ kHz}$		33		$\text{nV}/\sqrt{\text{Hz}}$
i_n	Input Referred Voltage Noise Density	$f = 1 \text{ kHz}$		0.26		$\text{pA}/\sqrt{\text{Hz}}$
THD+N	Total Harmonic Distortion + Noise	$f = 10 \text{ kHz}$		-66		dB
t_{PD}	Propagation Delay	Overdrive = 50 mV (Note 7)		8		μs
		Overdrive = 1V (Note 7)		6		
t_r	Rise Time	20% to 80% (Note 7)		5		μs
t_f	Fall Time	80% to 20% (Note 7)		5		μs

±15V Electrical Characteristics

Unless otherwise specified, all limits guaranteed for $T_A = 25^\circ\text{C}$, $V^+ = 15\text{V}$, $V^- = -15\text{V}$, $V_{CM} = V_{OUT} = 0\text{V}$ and $R_L > 1 \text{ M}\Omega$ to 0V .
Boldface limits apply at the temperature extremes

Symbol	Parameter	Conditions	Min (Note 6)	Typ (Note 5)	Max (Note 6)	Units
V_{OS}	Input Offset Voltage	$V_{CM} = -14.5\text{V}$ and $V_{CM} = 14.5\text{V}$	-4 -5	± 0.2	+4 +5	mV
TCV_{OS}	Input Offset Voltage Temperature Drift			± 2		$\mu\text{V}/^\circ\text{C}$
I_B	Input Bias Current	$V_{CM} = -14.5\text{V}$	-250 -300	-110		nA
		$V_{CM} = 14.5\text{V}$		40	80 90	
I_{OS}	Input Offset Current	$V_{CM} = -14.5\text{V}$ and $V_{CM} = 14.5\text{V}$		1	40 50	nA
CMRR	Common Mode Rejection Ratio	$-15\text{V} \leq V_{CM} \leq 12\text{V}$	84 82	115		dB
		$-15\text{V} \leq V_{CM} \leq 15\text{V}$	78 76	100		
PSRR	Power Supply Rejection Ratio	$2.7\text{V} \leq V_S \leq 30\text{V}$, $V_{CM} = -14.5\text{V}$	86 84	106		dB
CMVR	Common Mode Voltage Range	CMRR > 80 dB		-15.3	-15.0	V
			15.0	15.3		
A_{VOL}	Open Loop Voltage Gain	$-13\text{V} \leq V_O \leq 13\text{V}$ $R_L = 10 \text{ k}\Omega$ to 0V	25 15	200		V/mV
V_{OUT}	Output Voltage Swing High	$R_L = 10 \text{ k}\Omega$ to 0V $V_{ID} = 100 \text{ mV}$		135	300 400	mV from either rail
	Output Voltage Swing Low	$R_L = 10 \text{ k}\Omega$ to 0V $V_{ID} = -100 \text{ mV}$		160	300 400	
I_{OUT}	Output Current (Note 4)	Sourcing, $V_{OUT} = -15\text{V}$ $V_{ID} = 200 \text{ mV}$	5 3	10		mA
		Sinking, $V_{OUT} = 15\text{V}$ $V_{ID} = -200 \text{ mV}$	8 5	13		
I_S	Supply Current	$V_{CM} = -14.5\text{V}$ and $V_{CM} = 14.5\text{V}$		0.7	1.2 1.3	mA
SR	Slew Rate	$\pm 12\text{V}$ Step		1.9		$\text{V}/\mu\text{s}$
GBW	Gain Bandwidth	$f = 100 \text{ kHz}$, $R_L = 100 \text{ k}\Omega$		4.6		MHz
e_n	Input Referred Voltage Noise Density	$f = 1 \text{ kHz}$		31		$\text{nV}/\sqrt{\text{Hz}}$
i_n	Input Referred Voltage Noise Density	$f = 1 \text{ kHz}$		0.27		$\text{pA}/\sqrt{\text{Hz}}$
THD+N	Total Harmonic Distortion + Noise	$f = 10 \text{ kHz}$		-65		dB
t_{PD}	Propagation Delay	Overdrive = 50 mV (Note 7)		17		μs
		Overdrive = 1V (Note 7)		12		

Symbol	Parameter	Conditions	Min (Note 6)	Typ (Note 5)	Max (Note 6)	Units
t_r	Rise Time	20% to 80% (Note 7)		13		μs
t_f	Fall Time	80% to 20% (Note 7)		13		μs

Note 1: Absolute Maximum Ratings indicate limits beyond which damage to the device may occur. Operating Ratings indicate conditions for which the device is intended to be functional, but specific performance is not guaranteed. For guaranteed specifications and the test conditions, see the Electrical Characteristics.

Note 2: Human Body Model, applicable std. MIL-STD-883, Method 3015.7. Machine Model, applicable std. JESD22-A115-A (ESD MM std. of JEDEC) Field-Induced Charge-Device Model, applicable std. JESD22-C101-C (ESD FICDM std. of JEDEC).

Note 3: Applies to both single-supply and split-supply operation. Continuous short circuit operation at elevated ambient temperature can result in exceeding the maximum allowed junction temperature of 150°C.

Note 4: The maximum power dissipation is a function of $T_{J(\text{MAX})}$, θ_{JA} . The maximum allowable power dissipation at any ambient temperature is $P_D = (T_{J(\text{MAX})} - T_A)/\theta_{JA}$. All numbers apply for packages soldered directly unto a PC board.

Note 5: Typical values represent the most likely parametric norm as determined at the time of characterization. Actual typical values may vary over time and will also depend on the application and configuration. The typical values are not tested and are not guaranteed on shipped production material.

Note 6: All limits are guaranteed by testing or statistical analysis.

Note 7: The maximum differential voltage between the input pins is $V_{IN \text{ Differential}} = \pm 15V$.

Connection Diagram

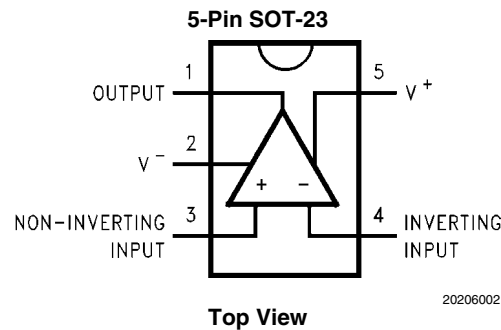

Ordering Information

Package	Part Number	Package Marking	Transport Media	NSC Drawing
5-Pin SOT-23	LM7341MF	AV4A	1k Units Tape and Reel	MF05A
	LM7341MFE		250 Units Tape and Reel	
	LM7341MFX		3k Units Tape and Reel	

Typical Performance Characteristics

Output Swing vs. Sourcing Current

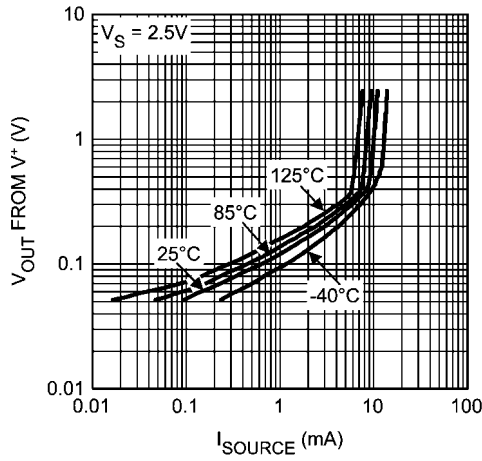

20206030

Output Swing vs. Sinking Current

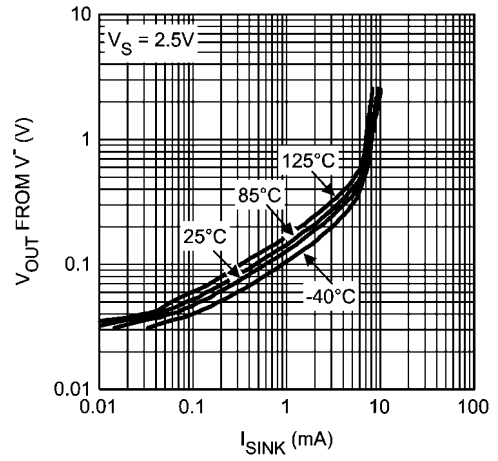

20206033

Output Swing vs. Sourcing Current

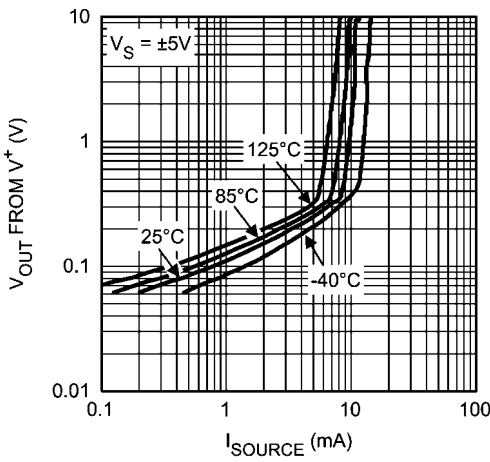

20206031

Output Swing vs. Sinking Current

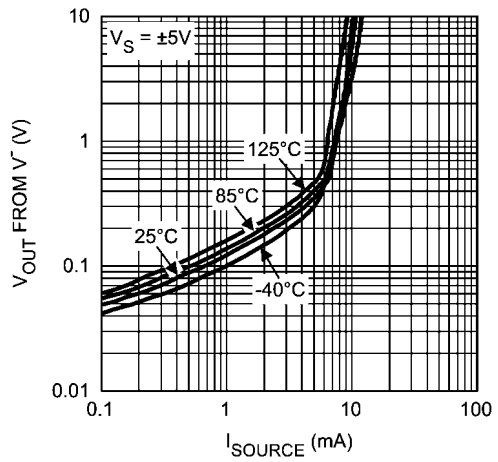

20206034

Output Swing vs. Sourcing Current

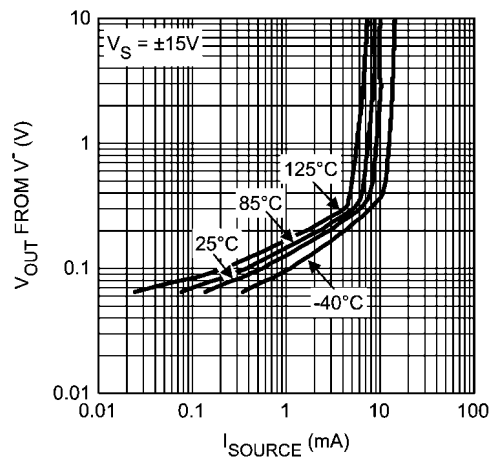

20206032

Output Swing vs. Sinking Current

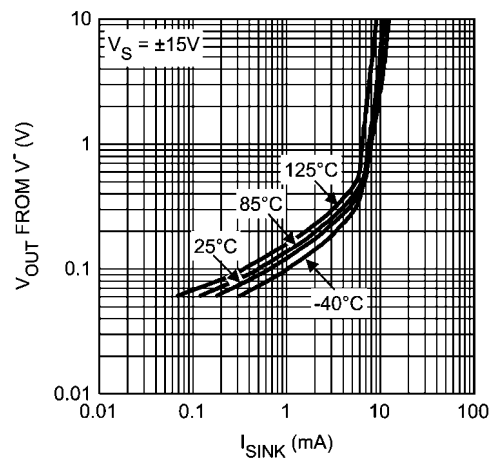

20206035

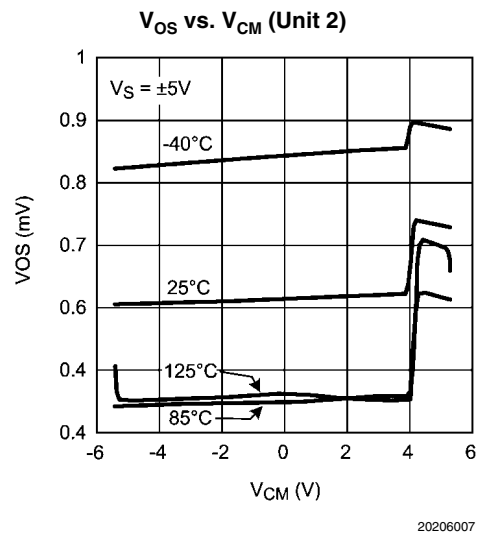
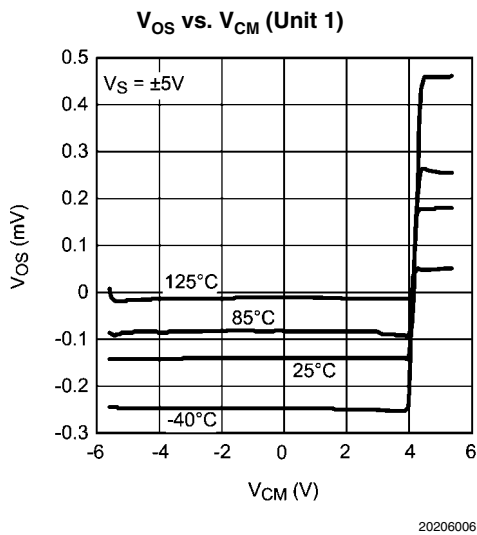
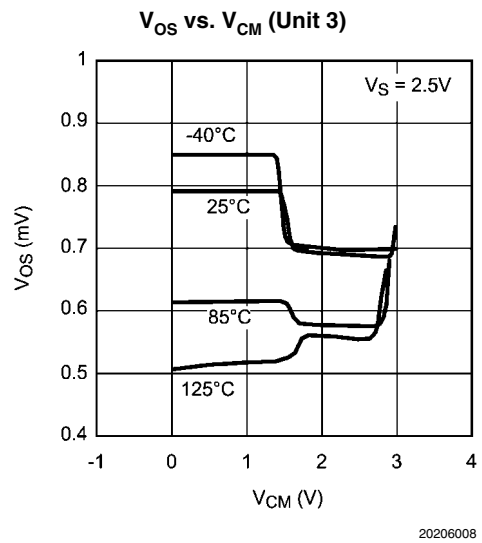
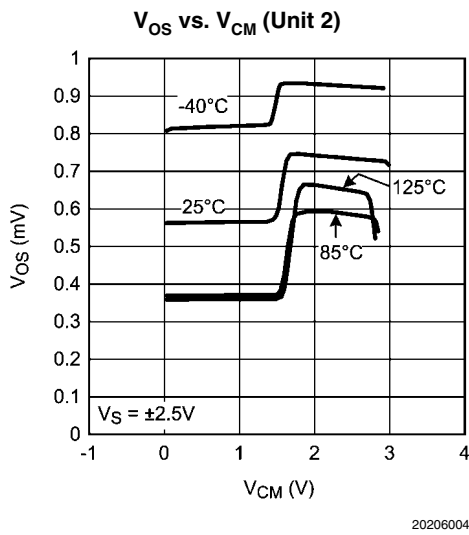
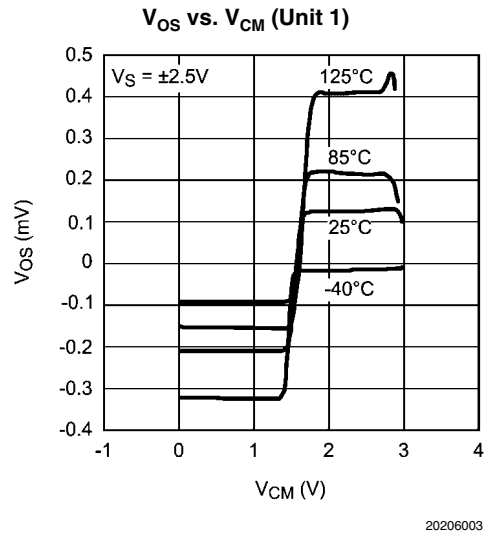
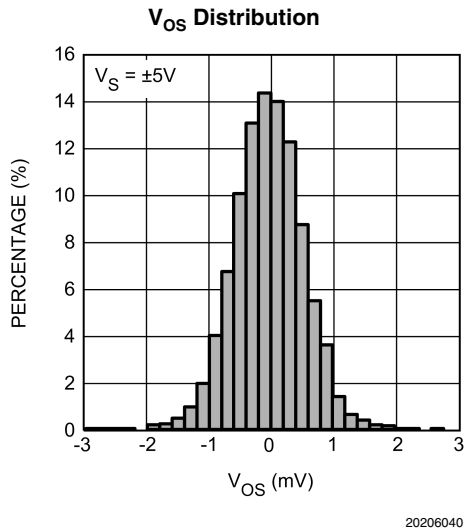

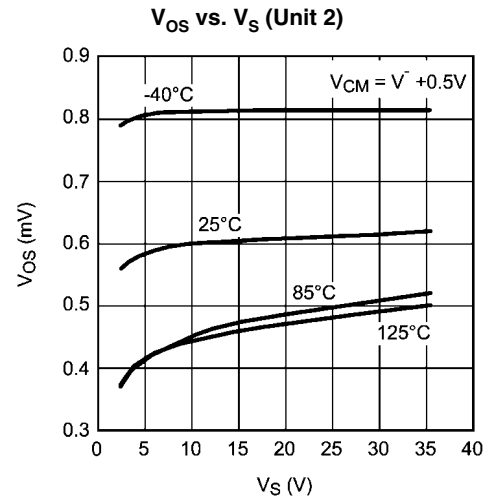
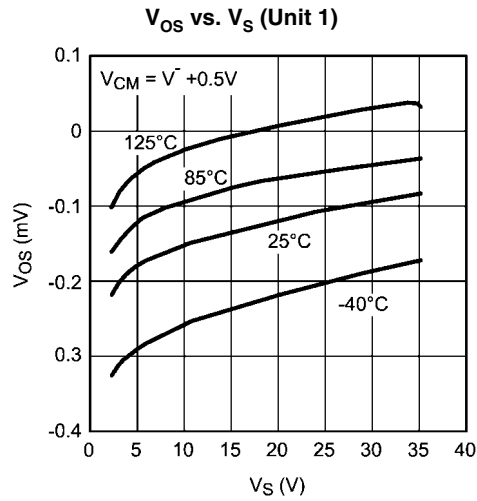
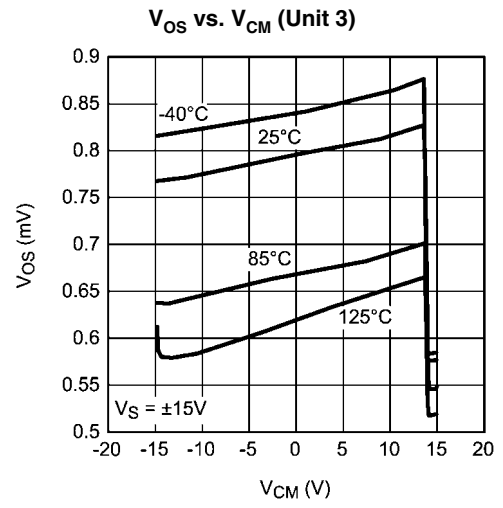
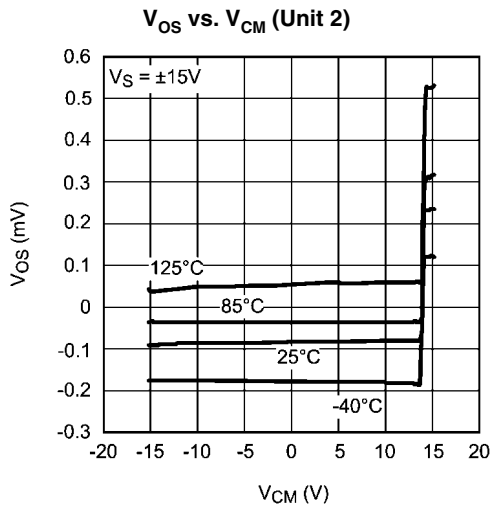
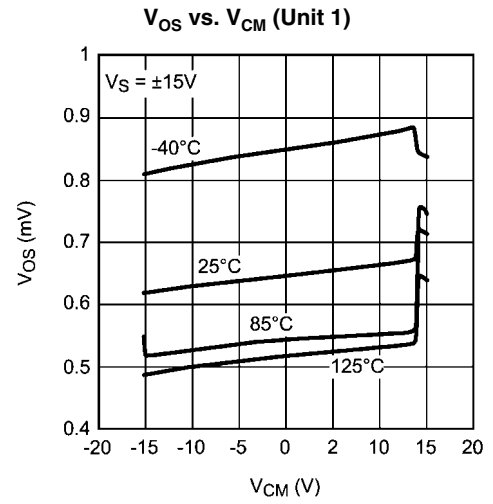
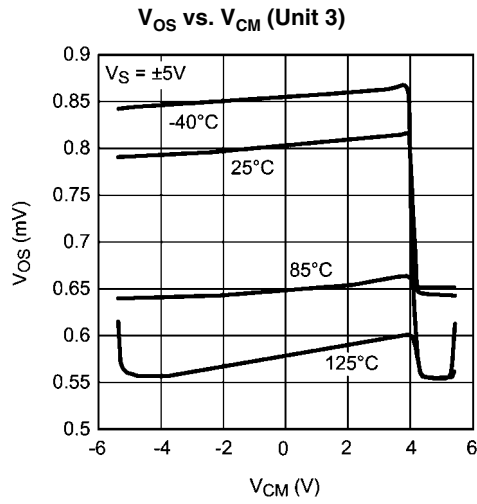

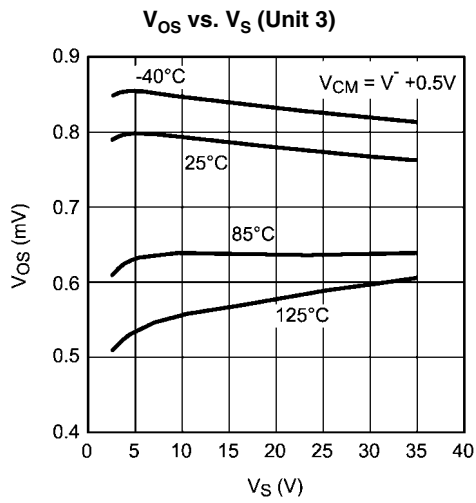

20206014

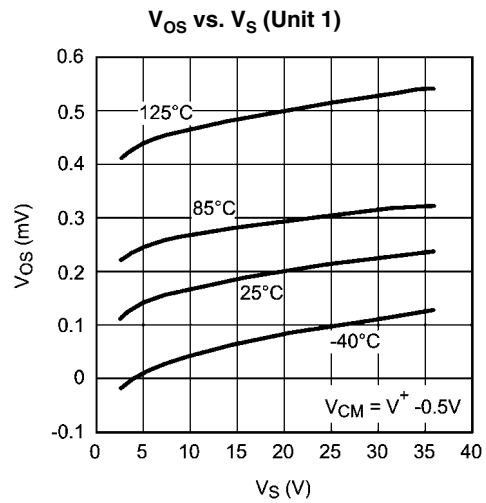

20206015

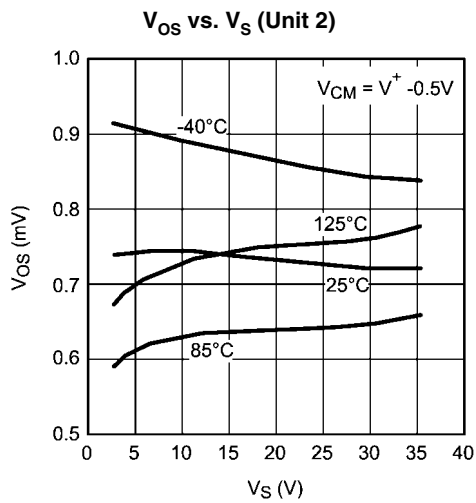

20206016

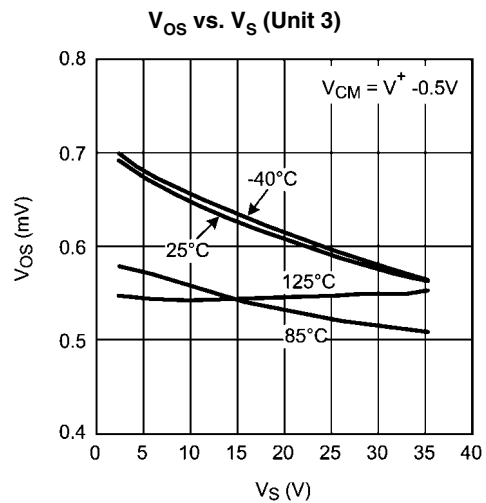

20206017

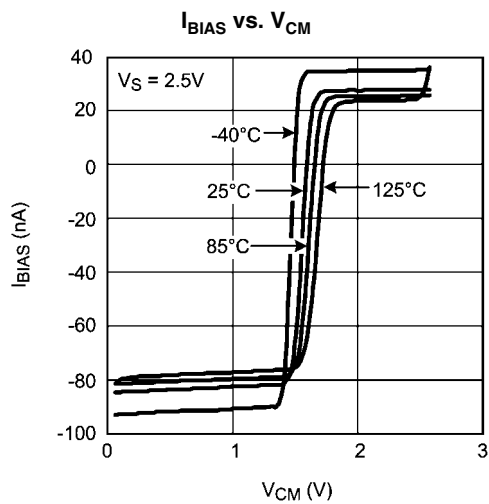

20206018

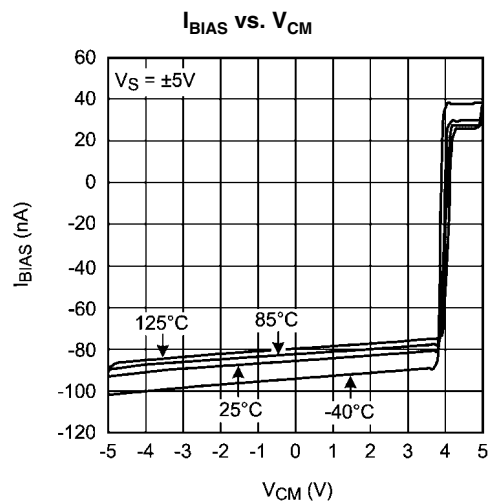

20206019

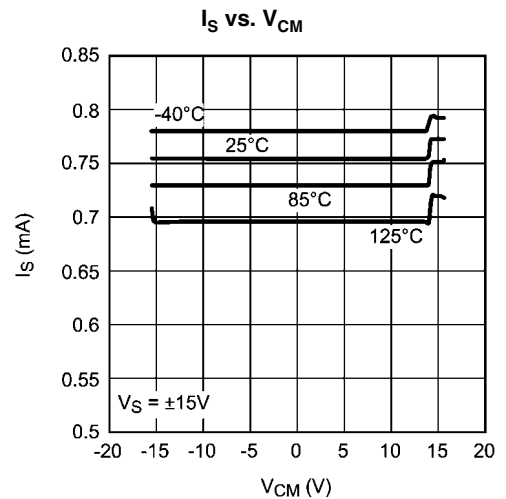
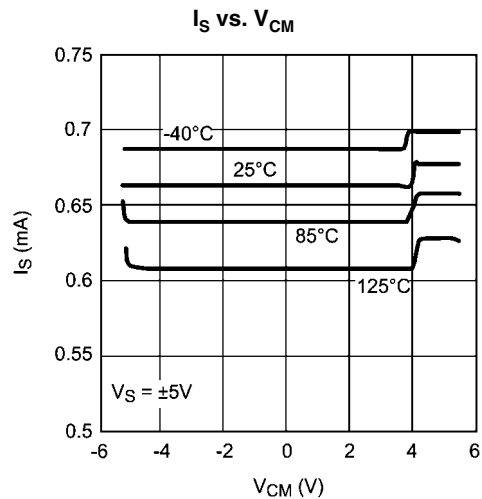
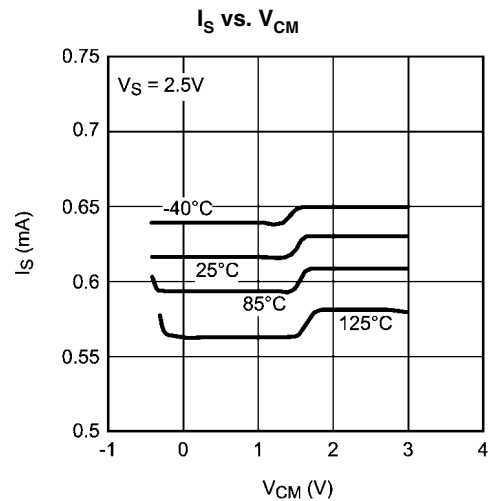
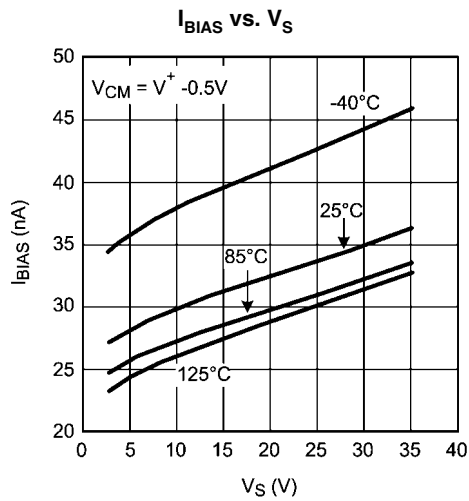
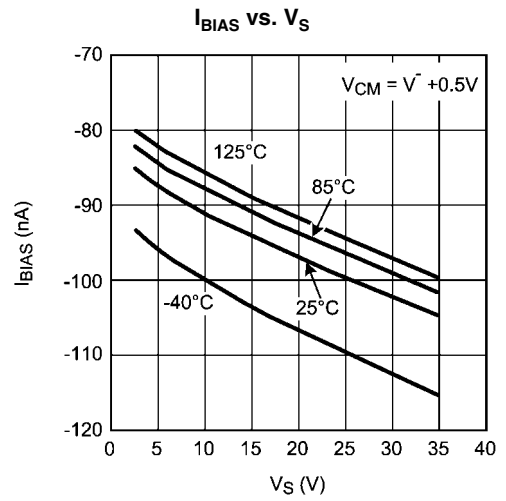
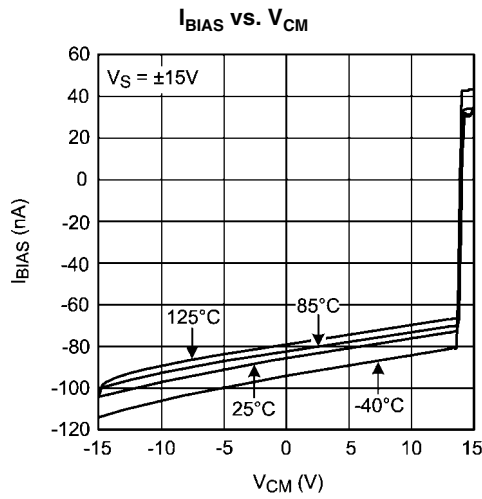

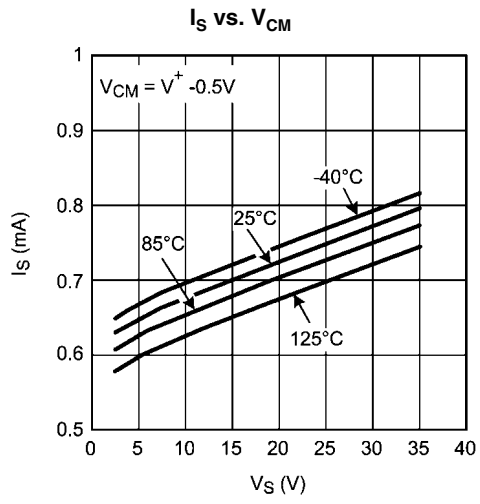
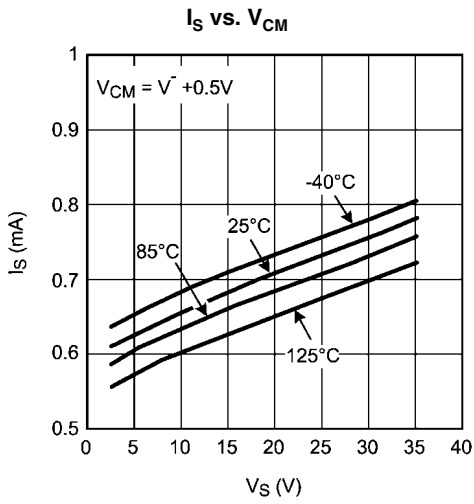

Positive Output Swing vs. Supply Voltage

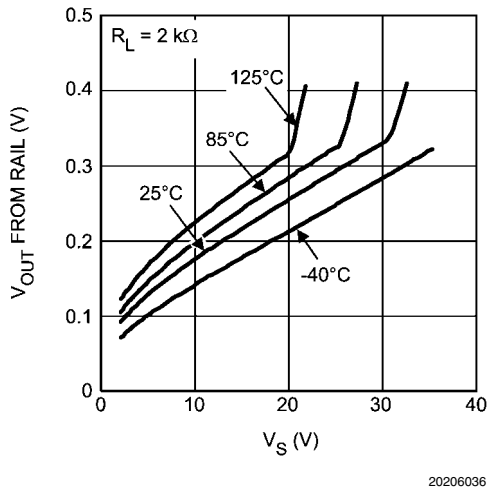

Positive Output Swing vs. Supply Voltage

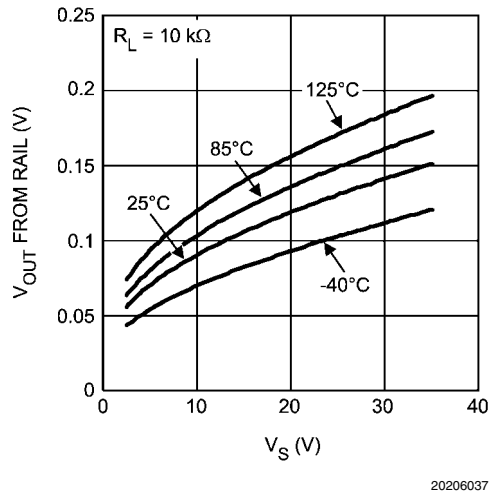

Negative Output Swing vs. Supply Voltage

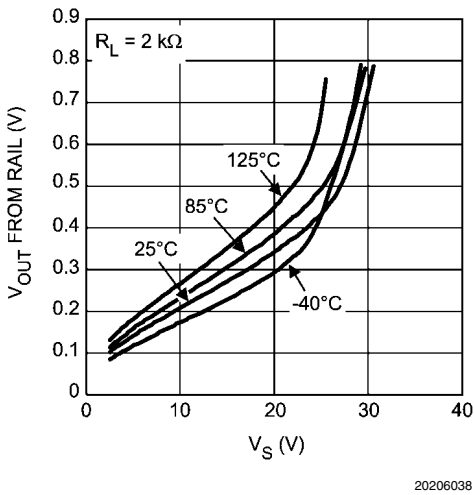

Negative Output Swing vs. Supply Voltage

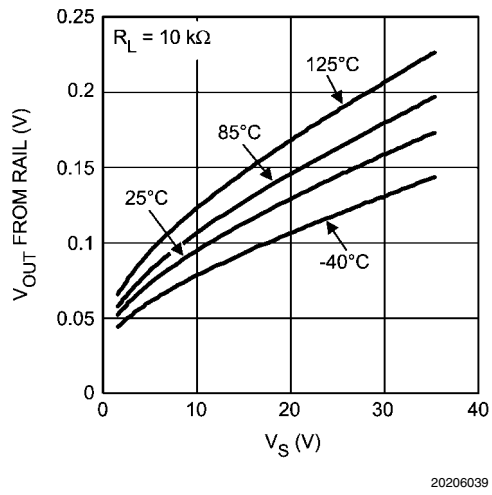

Open Loop Frequency with Various Capacitive Load

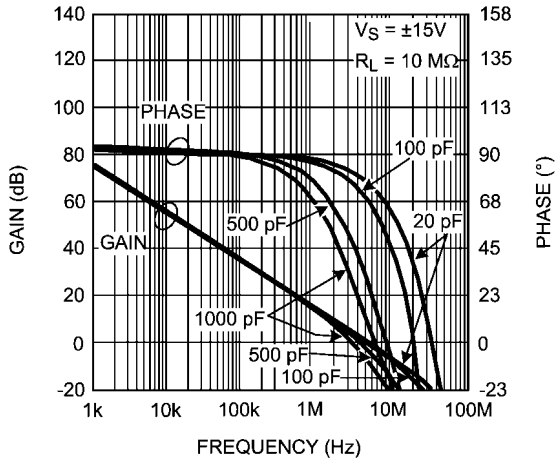

20206044

Open Loop Frequency with Various Resistive Load

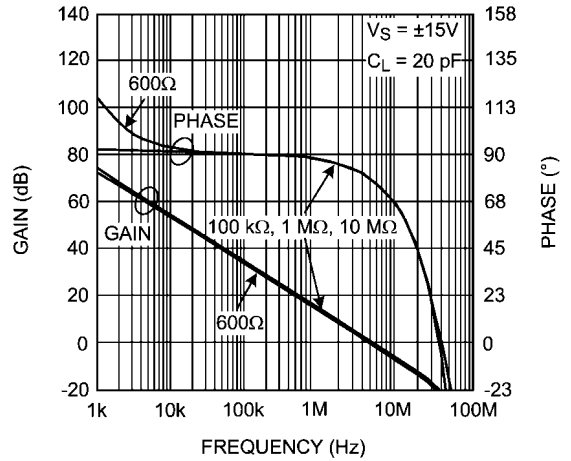

20206045

Open Loop Frequency with Various Supply Voltage

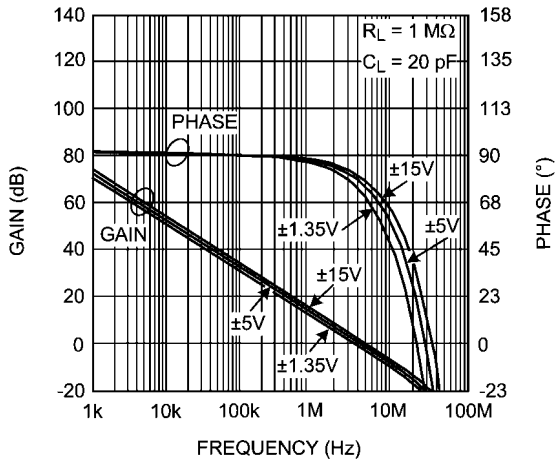

20206046

Open Loop Frequency Response with Various Temperatures

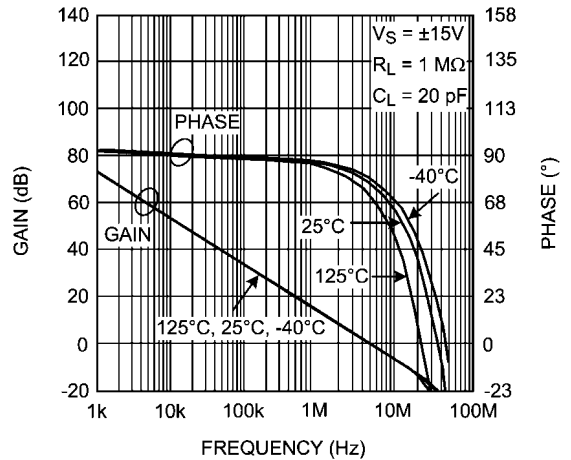

20206047

CMRR vs. Frequency

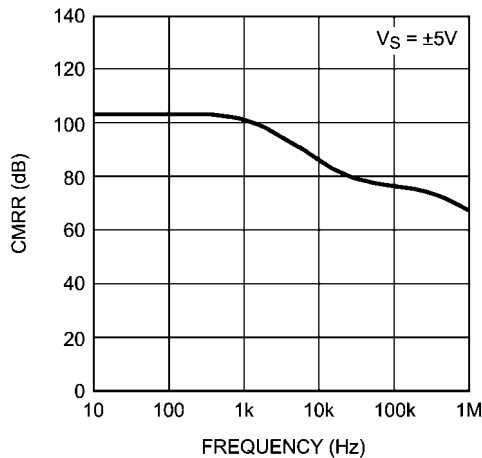

20206043

+PSRR vs. Frequency

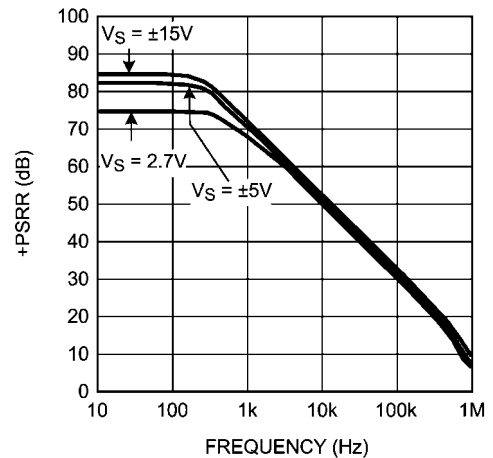

20206041

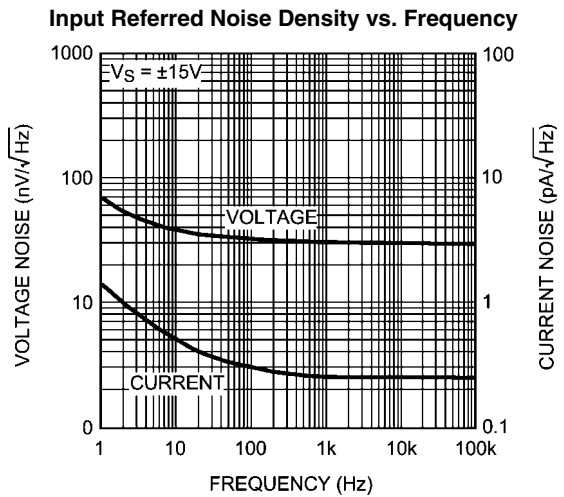
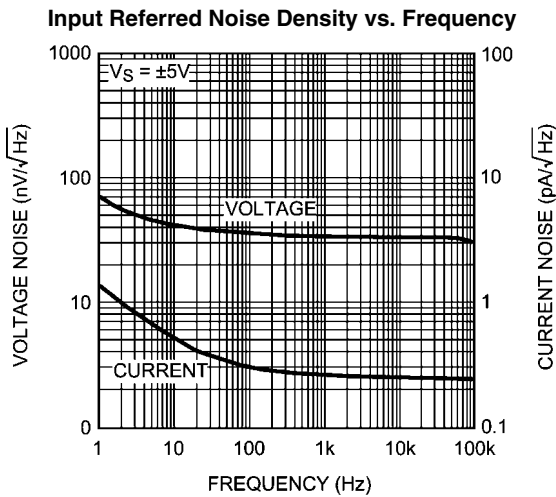
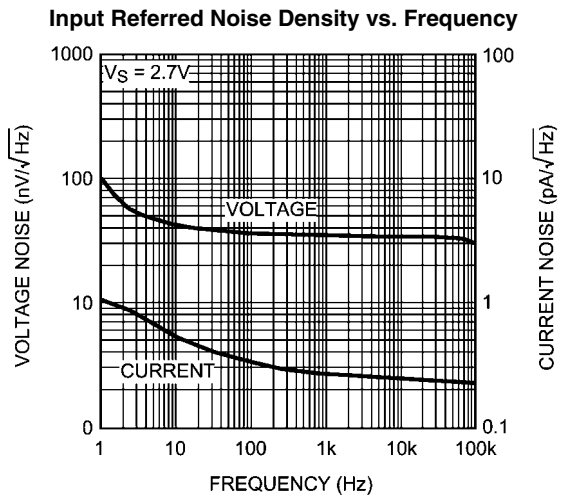
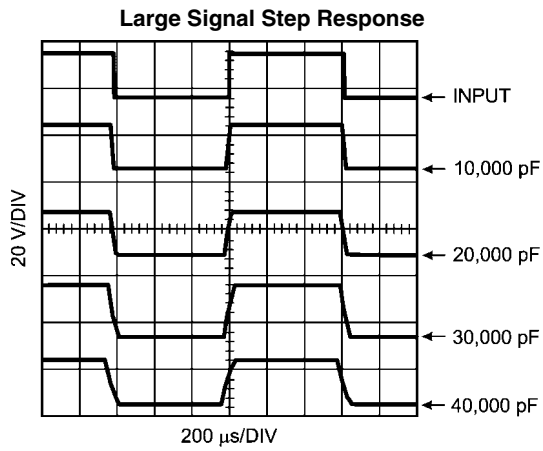
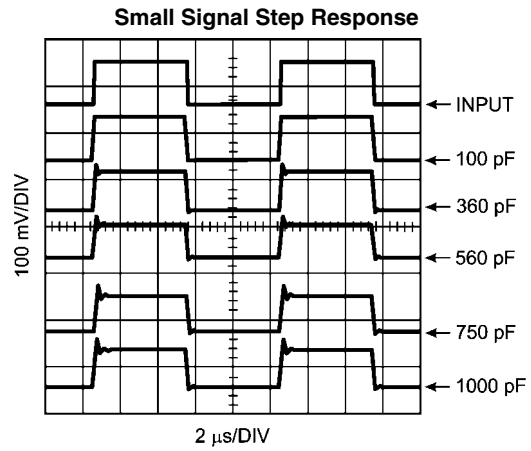
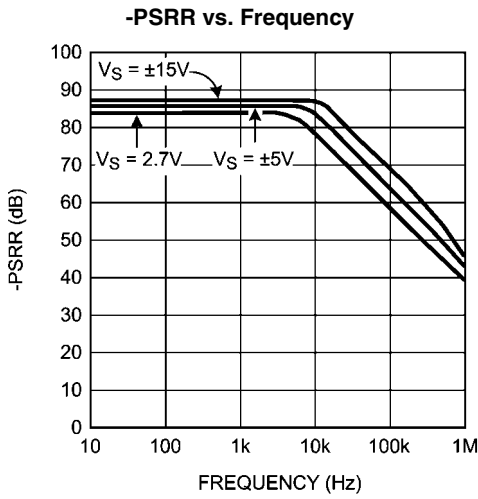

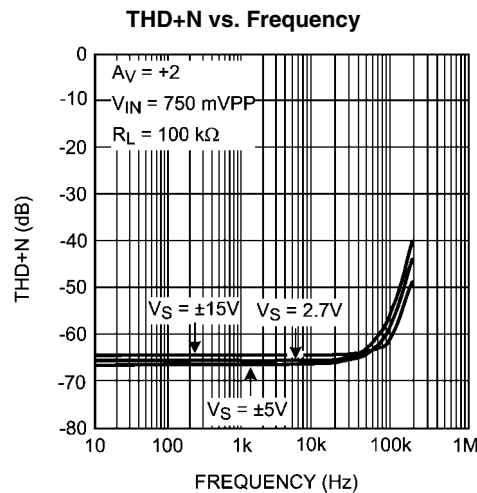

Application Information

GENERAL INFORMATION

Low supply current and wide bandwidth, greater than rail-to-rail input range, full rail-to-rail output, good capacitive load driving ability, wide supply voltage and low distortion all make the LM7341 ideal for many diverse applications.

The high common-mode rejection ratio and full rail-to-rail input range provides precision performance when operated in non-inverting applications where the common-mode error is added directly to the other system errors.

CAPACITIVE LOAD DRIVING

The LM7341 has the ability to drive large capacitive loads. For example, 1000 pF only reduces the phase margin to about 30 degrees.

POWER DISSIPATION

Although the LM7341 has internal output current limiting, shorting the output to ground when operating on a +30V power supply will cause the op amp to dissipate about 350 mW. This is a worst-case example. In the 5-pin SOT-23 package, the higher thermal resistance will cause a calculated rise of 113°C. This can raise the junction temperature to above the absolute maximum temperature of 150°C.

Operating from split supplies greatly reduces the power dissipated when the output is shorted. Operating on $\pm 15\text{V}$ supplies can only cause a temperature rise of 57°C in the 5-pin SOT-23 package, assuming the short is to ground.

WIDE SUPPLY RANGE

The high power-supply rejection ratio (PSRR) and common mode rejection ratio (CMRR) provide precision performance when operated on battery or other unregulated supplies. This advantage is further enhanced by the very wide supply range (2.5V–32V) offered by the LM7341. In situations where highly variable or unregulated supplies are present, the excellent PSRR and wide supply range of the LM7341 benefit the system designer with continued precision performance, even in such adverse supply conditions.

SPECIFIC ADVANTAGES OF 5-Pin SOT-23 (TinyPak)

The obvious advantage of the 5-pin SOT-23, TinyPak, is that it can save board space, a critical aspect of any portable or miniaturized system design. The need to decrease overall system size is inherent in any handheld, portable, or lightweight system application.

Furthermore, the low profile can help in height limited designs, such as consumer hand-held remote controls, sub-notebook computers, and PCMCIA cards.

An additional advantage of the tiny package is that it allows better system performance due to ease of package placement. Because the tiny package is so small, it can fit on the board right where the op amp needs to be placed for optimal performance, unconstrained by the usual space limitations. This optimal placement of the tiny package allows for many system enhancements, not easily achieved with the constraints of a larger package. For example, problems such as system noise due to undesired pickup of digital signals can be easily reduced or mitigated. This pick-up problem is often caused by long wires in the board layout going to or from an op amp. By placing the tiny package closer to the signal source and allowing the LM7341 output to drive the long wire, the signal becomes less sensitive to such pick-up. An overall reduction of system noise results.

Often times system designers try to save space by using dual or quad op amps in their board layouts. This causes a complicated board layout due to the requirement of routing several signals to and from the same place on the board. Using the tiny op amp eliminates this problem.

Additional space savings parts are available in tiny packages from National Semiconductor, including low power amplifiers, precision voltage references, and voltage regulators.

LOW DISTORTION, HIGH OUTPUT DRIVE CAPABILITY

The LM7341 offers superior low-distortion performance, with a total-harmonic-distortion-plus-noise of -66 dB at $f = 10\text{ kHz}$. The advantage offered by the LM7341 is its low distortion levels, even at high output current and low load resistance.

Typical Applications

HANDHELD REMOTE CONTROLS

The LM7341 offers outstanding specifications for applications requiring good speed/power trade-off. In applications such as remote control operation, where high bandwidth and low power consumption are needed. The LM7341 performance can easily meet these requirements.

OPTICAL LINE ISOLATION FOR MODEMS

The combination of the low distortion and good load driving capabilities of the LM7341 make it an excellent choice for driving opto-coupler circuits to achieve line isolation for modems. This technique prevents telephone line noise from coupling onto the modem signal. Superior isolation is achieved by coupling the signal optically from the computer modem to the telephone lines; however, this also requires a low distortion at relatively high currents. Due to its low distortion at high output drive currents, the LM7341 fulfills this need, in this and in other telecom applications.

REMOTE MICROPHONE IN PERSONAL COMPUTERS

Remote microphones in Personal Computers often utilize a microphone at the top of the monitor which must drive a long cable in a high noise environment. One method often used to reduce the noise is to lower the signal impedance, which reduces the noise pickup. In this configuration, the amplifier usually requires 30 dB–40 dB of gain, at bandwidths higher than most low-power CMOS parts can achieve. The LM7341 offers the tiny package, higher bandwidths, and greater output drive capability than other rail-to-rail input/output parts can provide for this application.

LM7341 AS A COMPARATOR

The LM7341 can also be used as a comparator and provides quite reasonable performance. Note however that unlike a typical comparator an op amp has a maximum allowed differential voltage between the input pins. For the LM7341, as stated in the Absolute Maximum Ratings section, this maximum voltage is $V_{IN\text{ Differential}} = \pm 15V$. Beyond this limit, even for a short time, damage to the device may occur.

As an inverting comparator at $V_S = 30V$ and 1V of overdrive there is typically 12 μs of propagation delay. At $V_S = 30V$ and 50 mV of overdrive there is typically 17 μs of propagation delay.

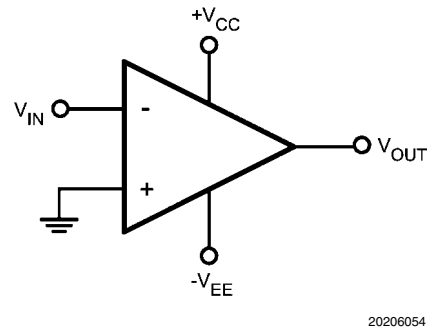

FIGURE 1. Inverting Comparator

Similarly a non-inverting comparator at $V_S = 30V$ and 1V of overdrive there is typically 12 μs of propagation delay. At $V_S = 30V$ and 50 mV of overdrive there is typically 17 μs of propagation delay.

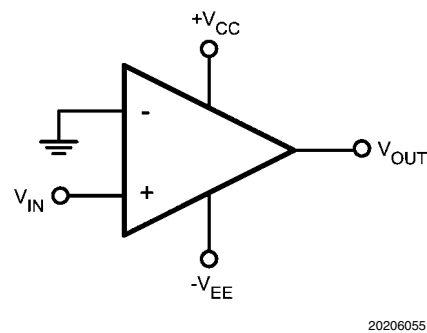

FIGURE 2. Non-Inverting Comparator

COMPARATOR WITH HYSTERESIS

The basic comparator configuration may oscillate or produce a noisy output if the applied differential input voltage is near the comparator's offset voltage. This usually happens when the input signal is moving very slowly across the comparator's switching threshold. This problem can be prevented by the addition of hysteresis or positive feedback.

INVERTING COMPARATOR WITH HYSTERESIS

The inverting comparator with hysteresis requires a three-resistor network that is referenced to the supply voltage V_{CC} of the comparator, as shown in *Figure 3*. When V_{IN} at the inverting input is less than V_A , the voltage at the non-inverting node of the comparator ($V_{IN} < V_A$), the output voltage is high (for simplicity assume V_{OUT} switches as high as V_{CC}). The three network resistors can be represented as $R_1 || R_3$ in series with R_2 . The lower input trip voltage V_{A1} is defined as

$$V_{A1} = V_{CC} R_2 / ((R_1 || R_3) + R_2)$$

When V_{IN} is greater than V_A ($V_{IN} > V_A$), the output voltage is low, very close to ground. In this case the three network re-

sistors can be presented as $R_2 || R_3$ in series with R_1 . The upper trip voltage V_{A2} is defined as

$$V_{A2} = V_{CC} (R_2 || R_3) / ((R_1 + (R_2 || R_3)))$$

The total hysteresis provided by the network is defined as

$$\Delta V_A = V_{A1} - V_{A2}$$

For example to achieve 50 mV of hysteresis when $V_{CC} = 30V$ set $R_1 = 4.02 \text{ k}\Omega$, $R_2 = 4.02 \text{ k}\Omega$, and $R_3 = 1.21 \text{ M}\Omega$. With these resistors selected the error due to input bias current is approximately 1 mV. To minimize this error it is best to use low resistor values on the inputs.

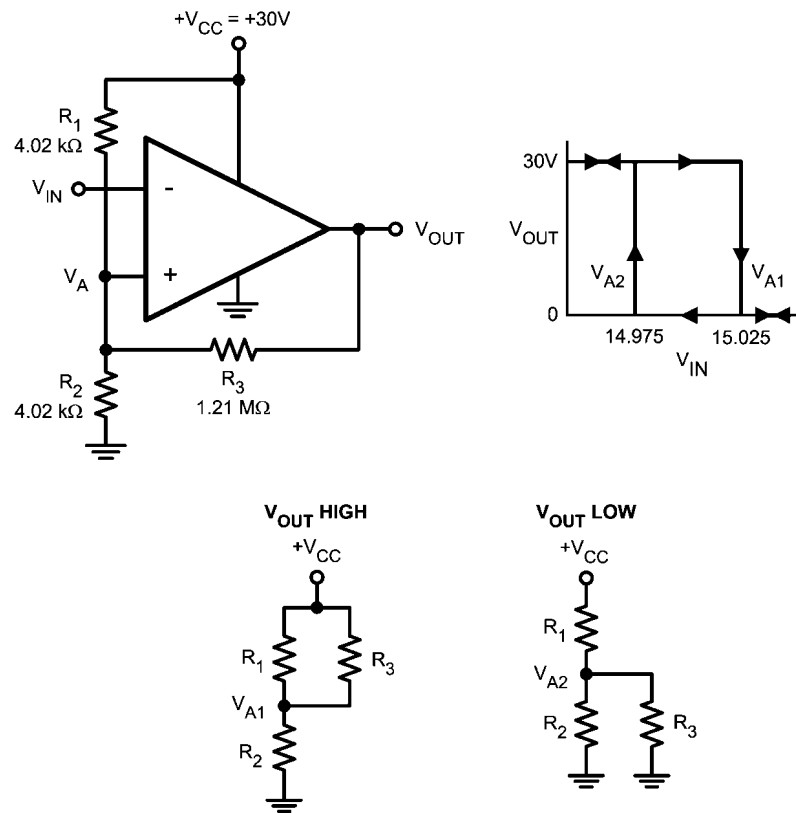

20206056

FIGURE 3. Inverting Comparator with Hysteresis

NON-INVERTING COMPARATOR WITH HYSTERESIS

A non-inverting comparator with hysteresis requires a two-resistor network, and a voltage reference (V_{REF}) at the inverting input. When V_{IN} is low, the output is also low. For the output to switch from low to high, V_{IN} must rise up to V_{IN1} where V_{IN1} is calculated by

$$V_{IN1} = R_1 \cdot (V_{REF}/R_2) + V_{REF}$$

When V_{IN} is high, the output is also high, to make the comparator switch back to its low state, V_{IN} must equal V_{REF} before V_A will again equal V_{REF} . V_{IN} can be calculated by

$$V_{IN2} = (V_{REF} (R_1 + R_2) - V_{CC}R_1)/R_2$$

The hysteresis of this circuit is the difference between V_{IN1} and V_{IN2} .

$$\Delta V_{IN} = V_{CC}R_1/R_2$$

For example to achieve 50 mV of hysteresis when $V_{CC} = 30V$ set $R_1 = 20\Omega$ and $R_2 = 12.1 k\Omega$.

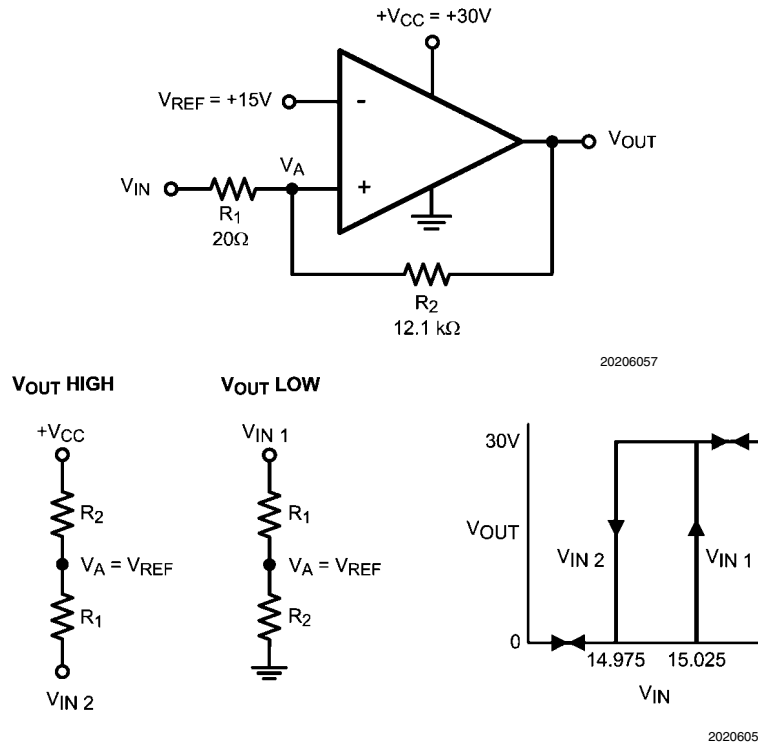

FIGURE 4. Non-Inverting Comparator with Hysteresis

OTHER SOT-23 AMPLIFIERS

The **LM7321** is a rail-to-rail input and output amplifier that can tolerate unlimited capacitive load. It works from 2.7V to $\pm 15V$ and across the $-40^{\circ}C$ to $125^{\circ}C$ temperature range. It has 20 MHz gain-bandwidth, and is available in both 5-Pin SOT-23 and 8-Pin SOIC packages.

The **LM6211** is a 20 MHz part with CMOS input, which runs on 5V to 24V single supplies. It has rail-to-rail output and low noise.

The **LMP7701** is a rail-to-rail input and output precision part with an input voltage offset under 220 microvolts and low noise. It has 2.5 MHz bandwidth and works on 2.7V to 12V supplies.

SMALLER SC70 AMPLIFIERS

The **LMV641** is a 10 MHz amplifier which uses only 140 micro amps of supply current. The input voltage offset is less than 0.5 mV.

The **LMV851** is an 8 MHz amplifier which uses only 0.4 mA supply current, and is available in the smaller SC70 package. The LMV851 also resists Electro Magnetic Interference (EMI) from mobile phones and similar high frequency sources. It works on 2.7V to 5.5 V supplies.

Detailed information on these and a wide range of other parts can be found at www.national.com.

Physical Dimensions inches (millimeters) unless otherwise noted

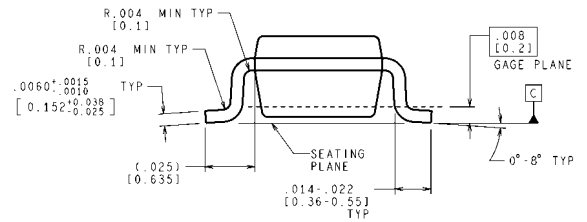
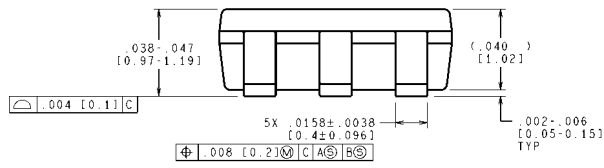
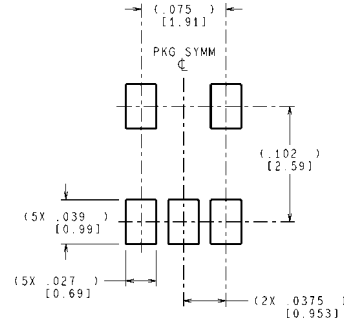
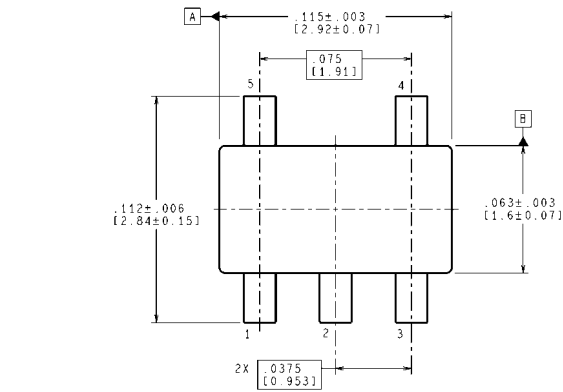

CONTROLLING DIMENSION IS INCH
 VALUES IN [] ARE MILLIMETERS
 DIMENSIONS IN () FOR REFERENCE ONLY

5-Pin SOT-23
NS Package Number MF05A

MF05A (Rev D)

Notes

LM7341

Notes

For more National Semiconductor product information and proven design tools, visit the following Web sites at:

Products		Design Support	
Amplifiers	www.national.com/amplifiers	WEBENCH	www.national.com/webench
Audio	www.national.com/audio	Analog University	www.national.com/AU
Clock Conditioners	www.national.com/timing	App Notes	www.national.com/appnotes
Data Converters	www.national.com/adc	Distributors	www.national.com/contacts
Displays	www.national.com/displays	Green Compliance	www.national.com/quality/green
Ethernet	www.national.com/ethernet	Packaging	www.national.com/packaging
Interface	www.national.com/interface	Quality and Reliability	www.national.com/quality
LVDS	www.national.com/lvds	Reference Designs	www.national.com/refdesigns
Power Management	www.national.com/power	Feedback	www.national.com/feedback
Switching Regulators	www.national.com/switchers		
LDOs	www.national.com/lido		
LED Lighting	www.national.com/led		
PowerWise	www.national.com/powerwise		
Serial Digital Interface (SDI)	www.national.com/sdi		
Temperature Sensors	www.national.com/tempsensors		
Wireless (PLL/VCO)	www.national.com/wireless		

THE CONTENTS OF THIS DOCUMENT ARE PROVIDED IN CONNECTION WITH NATIONAL SEMICONDUCTOR CORPORATION ("NATIONAL") PRODUCTS. NATIONAL MAKES NO REPRESENTATIONS OR WARRANTIES WITH RESPECT TO THE ACCURACY OR COMPLETENESS OF THE CONTENTS OF THIS PUBLICATION AND RESERVES THE RIGHT TO MAKE CHANGES TO SPECIFICATIONS AND PRODUCT DESCRIPTIONS AT ANY TIME WITHOUT NOTICE. NO LICENSE, WHETHER EXPRESS, IMPLIED, ARISING BY ESTOPPEL OR OTHERWISE, TO ANY INTELLECTUAL PROPERTY RIGHTS IS GRANTED BY THIS DOCUMENT.

TESTING AND OTHER QUALITY CONTROLS ARE USED TO THE EXTENT NATIONAL DEEMS NECESSARY TO SUPPORT NATIONAL'S PRODUCT WARRANTY. EXCEPT WHERE MANDATED BY GOVERNMENT REQUIREMENTS, TESTING OF ALL PARAMETERS OF EACH PRODUCT IS NOT NECESSARILY PERFORMED. NATIONAL ASSUMES NO LIABILITY FOR APPLICATIONS ASSISTANCE OR BUYER PRODUCT DESIGN. BUYERS ARE RESPONSIBLE FOR THEIR PRODUCTS AND APPLICATIONS USING NATIONAL COMPONENTS. PRIOR TO USING OR DISTRIBUTING ANY PRODUCTS THAT INCLUDE NATIONAL COMPONENTS, BUYERS SHOULD PROVIDE ADEQUATE DESIGN, TESTING AND OPERATING SAFEGUARDS.

EXCEPT AS PROVIDED IN NATIONAL'S TERMS AND CONDITIONS OF SALE FOR SUCH PRODUCTS, NATIONAL ASSUMES NO LIABILITY WHATSOEVER, AND NATIONAL DISCLAIMS ANY EXPRESS OR IMPLIED WARRANTY RELATING TO THE SALE AND/OR USE OF NATIONAL PRODUCTS INCLUDING LIABILITY OR WARRANTIES RELATING TO FITNESS FOR A PARTICULAR PURPOSE, MERCHANTABILITY, OR INFRINGEMENT OF ANY PATENT, COPYRIGHT OR OTHER INTELLECTUAL PROPERTY RIGHT.

LIFE SUPPORT POLICY

NATIONAL'S PRODUCTS ARE NOT AUTHORIZED FOR USE AS CRITICAL COMPONENTS IN LIFE SUPPORT DEVICES OR SYSTEMS WITHOUT THE EXPRESS PRIOR WRITTEN APPROVAL OF THE CHIEF EXECUTIVE OFFICER AND GENERAL COUNSEL OF NATIONAL SEMICONDUCTOR CORPORATION. As used herein:

Life support devices or systems are devices which (a) are intended for surgical implant into the body, or (b) support or sustain life and whose failure to perform when properly used in accordance with instructions for use provided in the labeling can be reasonably expected to result in a significant injury to the user. A critical component is any component in a life support device or system whose failure to perform can be reasonably expected to cause the failure of the life support device or system or to affect its safety or effectiveness.

National Semiconductor and the National Semiconductor logo are registered trademarks of National Semiconductor Corporation. All other brand or product names may be trademarks or registered trademarks of their respective holders.

Copyright© 2008 National Semiconductor Corporation

For the most current product information visit us at www.national.com



**National Semiconductor
Americas Technical
Support Center**
Email: support@nsc.com
Tel: 1-800-272-9959

**National Semiconductor Europe
Technical Support Center**
Email: europe.support@nsc.com
German Tel: +49 (0) 180 5010 771
English Tel: +44 (0) 870 850 4288

**National Semiconductor Asia
Pacific Technical Support Center**
Email: ap.support@nsc.com

**National Semiconductor Japan
Technical Support Center**
Email: jpn.feedback@nsc.com