

# ASSP For Power Supply Applications

Bi-CMOS

## Battery Backup IC

# MB3790

### ■ DESCRIPTION

The MB3790 is designed to control power supplies to SRAM, logic IC, or other circuit devices and protects them against momentary power failures by using backup batteries. In addition to its function to supply the power to these devices, it has a function to switch the source of power to the primary or secondary backup battery when the power supply voltage drops below a predetermined level. Also, it outputs a reset signal when the power supply turns on or off or when a fault occurs in the power supply.

Ideally designed as a single-chip IC for power supply control, the MB3790 consumes only a minimal current and comes in a thin-type package. Therefore, it is best suited for power supply control in memory cards and similar other devices.

### ■ FEATURES

- Input circuit current consumption when non-loaded: 50  $\mu$ A [Typ]
- Output drive current: 200 mA [Max]
- Resistance between input and output: 0.5 ohms [Typ]
- Input power-down detection level: 4.2 V  $\pm$  2.5 %

(Continued)

### ■ PACKAGES

16-pin Plastic SOP

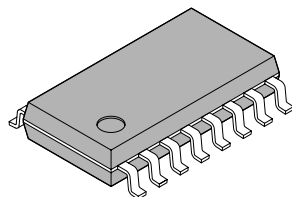

(FPT-16P-M06)

20-pin Plastic TSSOP\*

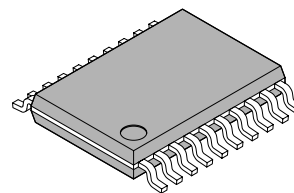

(FPT-20P-M04)

\* : Since the TSSOP is an extremely thin package, use a partial heating method when mounting the device.

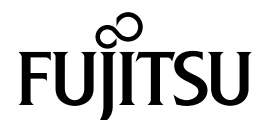
The Fujitsu logo, consisting of the word "FUJITSU" in a bold, sans-serif font with a stylized infinity symbol above the letter "I".

# MB3790

(Continued)

- On-chip power-on reset circuit
- Primary battery voltage-down detection levels: 2.65 V, 2.37 V
- On-chip secondary battery recharging function
- Output current during battery backup:  $V_{BAT1}$ : 500  $\mu$ A [Max],  $V_{BAT2}$ : 50  $\mu$ A [Max]
- Leakage current: 0.5  $\mu$ A [Max]

## ■ PIN ASSIGNMENTS

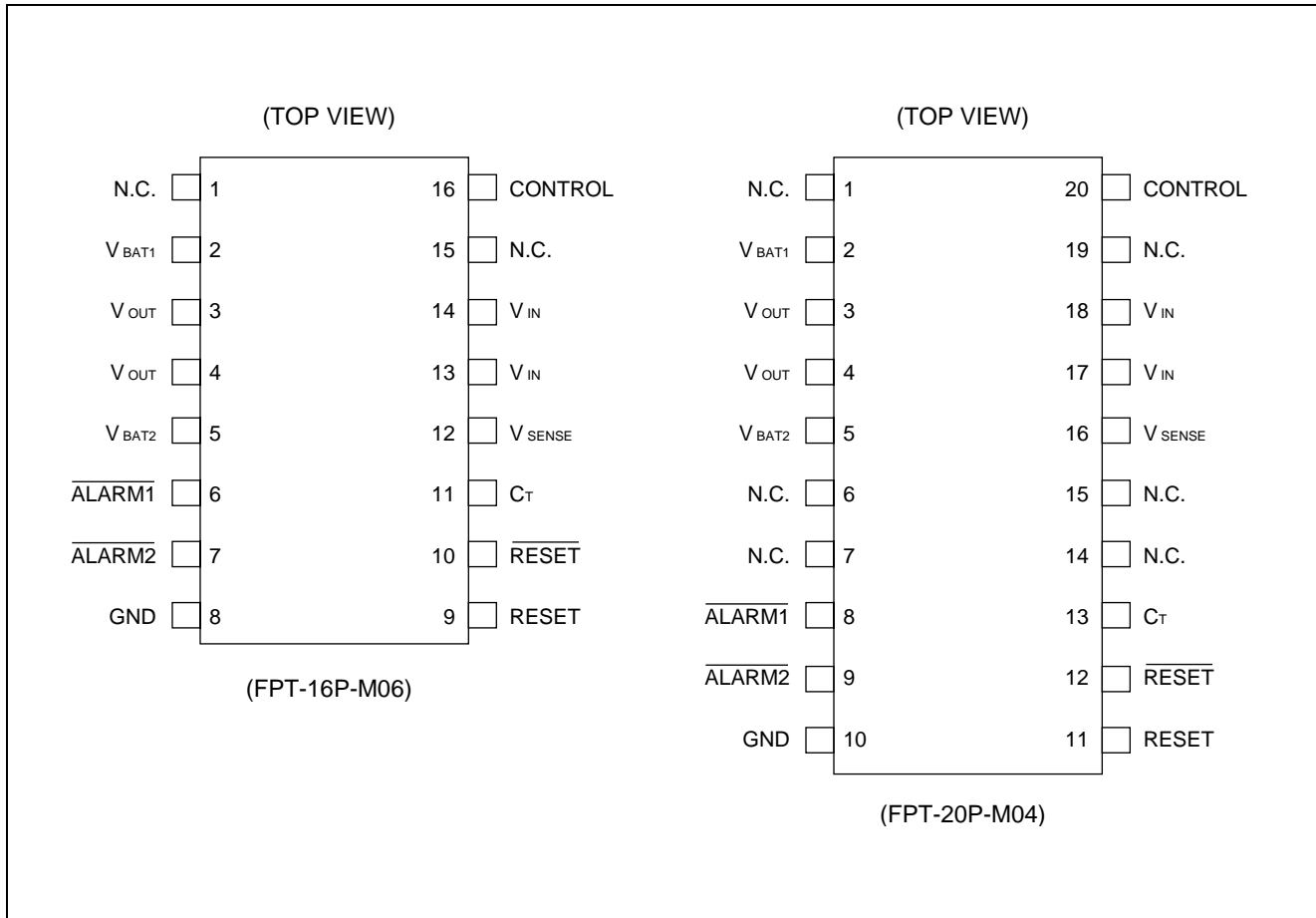

## ■ BLOCK DIAGRAM

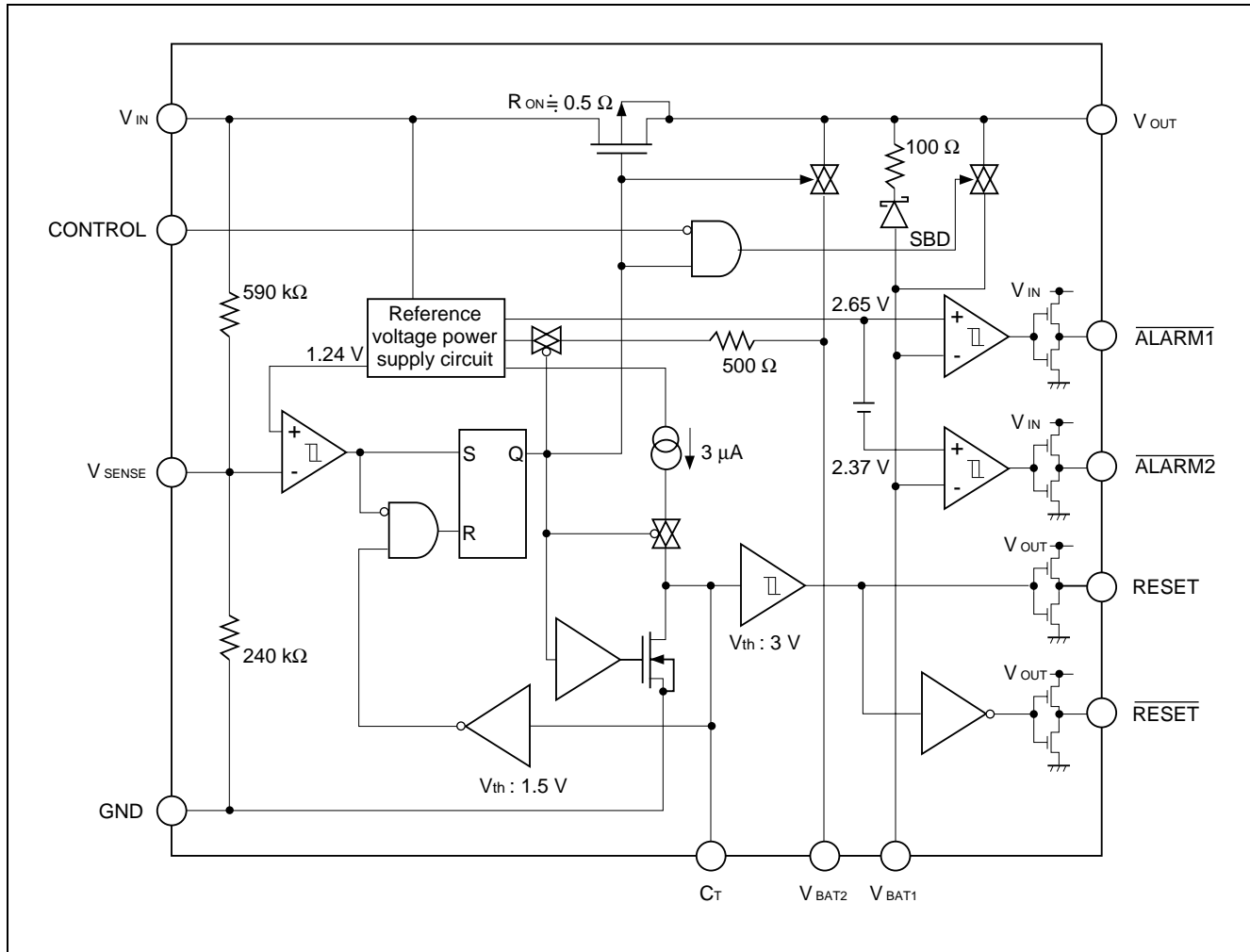

## ■ PIN DESCRIPTION

Pin number		Symbol	I/O	Name and function
16P	20P			
1	1	N.C.	—	Non connection
2	2	V <sub>BAT1</sub>	I	This pin connects to the primary battery.
3, 4	3, 4	V <sub>OUT</sub>	O	These pins supply the output voltage. (Range of output current value I <sub>OUT</sub> ≤ 200 mA)
5	5	V <sub>BAT2</sub>	I/O	This pin connects to the secondary battery. When the power supply voltage is greater than or equal to the detection level (i.e., V <sub>INH</sub> ), the secondary battery is recharged using the constant-voltage method of charging.
—	6, 7	N.C.	—	Non connection
6	8	$\overline{\text{ALARM1}}$	O	This is an open-collector output pin for a primary battery alarm signal. When the power supply voltage is greater than or equal to V <sub>INH</sub> , it monitors the primary battery voltage. If the power supply voltage is less than V <sub>INL</sub> , it does not monitor the primary battery voltage. If V <sub>BAT1</sub> is less than or equal to 2.65 V, its output voltage is forced to a Low level.
7	9	$\overline{\text{ALARM2}}$	O	This is an open-collector output pin for a primary battery alarm signal. When the power supply voltage is greater than or equal to V <sub>INH</sub> , it monitors the primary battery voltage. If the power supply voltage is less than V <sub>INL</sub> , it does not monitor the primary battery voltage. If V <sub>BAT1</sub> is less than or equal to 2.37 V, its output voltage is forced to a Low level.
8	10	GND	—	This pin connects to the ground (0 V).
9	11	RESET	O	This pin outputs a reset signal. When the power supply voltage is less than or equal to V <sub>INL</sub> , it outputs a High level. If the power supply voltage of SRAM is less than the designated range, it directly controls the $\overline{\text{CE}}$ or $\overline{\text{CS}}$ of SRAM to disable writes and thereby protect the data in memory.
10	12	$\overline{\text{RESET}}$	O	This pin outputs an inverted signal of RESET.
11	13	C <sub>T</sub>	—	This pin is used to set the reset pulse width. Insert a capacitor between this pin and GND to set the pulse width.
—	14, 15	N.C.	—	Non connection
12	16	V <sub>SENSE</sub>	I	This pin accepts comparator input for detecting the power supply voltage level. For details, refer to APPLICATION in this data sheet.
13, 14	17, 18	V <sub>IN</sub>	I	These pins accept the input voltage for the device.
15	19	N.C.	—	Non connection
16	20	CONTROL	I	This pin is used for output control. For details, refer to APPLICATION in this data sheet.

## ■ FUNCTIONAL DESCRIPTION

### 1. Battery Backup Function

- When the power supply voltage exceeds the voltage detection level (i.e.,  $V_{INH}$ ), the device outputs a current of up to 200 mA from the  $V_{IN}$  power supply to the load circuit via the  $V_{OUT}$  pin.
- When the power supply voltage is less than or equal to  $V_{INL}$ , the device switches the source of power for  $V_{OUT}$  from  $V_{IN}$  to the primary or secondary battery for backup purposes.

### 2. Power Supply Voltage Level Detect Function

When the power supply voltage drops below  $V_{INL}$ , the voltage level detection comparator is actuated to perform the following (note that the detection voltage level has the hysteresis characteristics listed in ELECTRICAL CHARACTERISTICS in this data sheet):

- The comparator first outputs the RESET signal (High level).
- It switches the source of power for the load circuit to the primary or secondary battery.

The power supply voltage detection level can be adjusted by fitting an external resistor to the  $V_{SENSE}$  pin. When adjusting the detection level, be sure to set it to 4.0 V or higher by considering the power supply voltage for the internal circuit operation.

In addition, the detection set time can be extended by connecting a capacitor. For this method of adjustment, refer to APPLICATION in this data sheet.

### 3. Reference Voltage Circuit

This is a temperature-compensated reference voltage circuit of a band gap type so that it outputs a trimming-adjusted exact reference voltage.

The reference voltage power supply is used to set the reference voltage/constant current values of the detection circuit, as well as the secondary battery recharging voltage.

### 4. Power-on Reset Function

By charging the capacitor connected to the  $C_T$  pin with constant current (approx. 3  $\mu$ A), this function determines the reset pulse width. The calculation formula for this is given below:

$$\text{Reset pulse width } t_{PO} \text{ (s)} \cong C_T \text{ (F)} \times 10^6$$

$$\text{(When } C_T = 1000 \text{ pF, } t_{PO} \cong 1 \text{ ms [Typ])}$$

### 5. Primary Battery Voltage Detection Function

If the primary battery voltage drops below the detection level when the power supply voltage is greater than or equal to  $V_{INL}$ , the device outputs an alarm signal (Low level) from the CMOS output pin,  $\overline{\text{ALARM1}}$  or  $\overline{\text{ALARM2}}$ .

Note that the voltage level detection comparator has the hysteresis characteristics listed in ELECTRICAL CHARACTERISTICS in this data sheet.

- When the primary battery voltage is 2.65 V [Typ] or less:  
The  $\overline{\text{ALARM1}}$  output pin is forced to a Low level to issue an alarm indicating that it's time to replace the primary battery.
- When the primary battery voltage is 2.37 V [Typ] or less:  
The  $\overline{\text{ALARM2}}$  output pin is forced to a low level to issue an alarm indicating that the primary battery voltage is less than the voltage necessary to retain the SRAM data (approx. 2.0 V)

### 6. Secondary Battery Recharging Function

When the power supply voltage is greater than or equal to  $V_{INL}$ , the device recharges the secondary battery using the constant-voltage method of charging. Note that the typical value of the device's internal recharging resistor is 500 ohms.

## DESCRIPTION OF OPERATION

### 1. Operation When the Input Voltage Goes On or Off

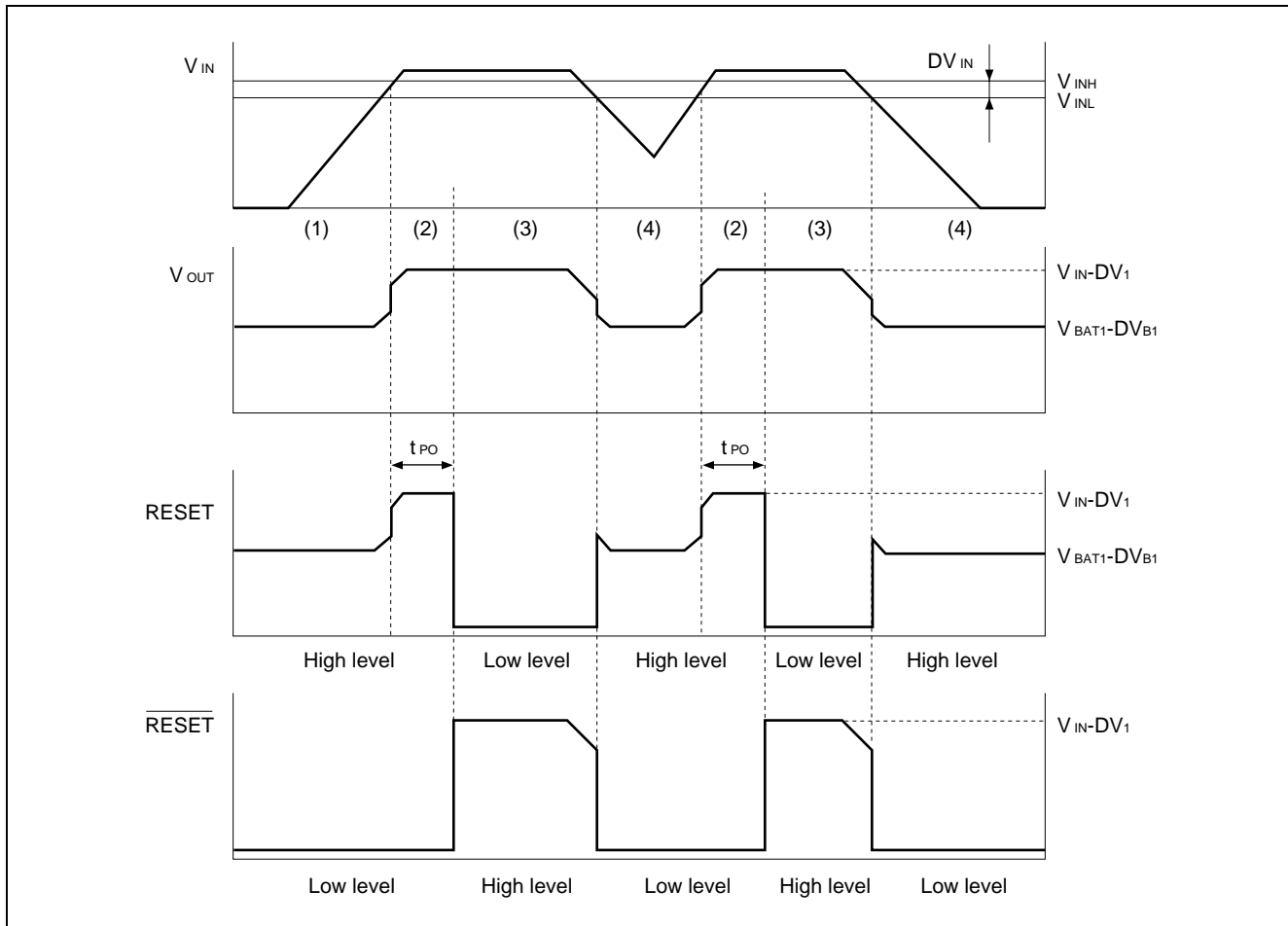

#### (1) Power-on

While the power supply voltage is less than  $V_{INH}$  (4.3 V Typ), the protected devices such as SRAM or a microprocessor are in the standby mode with the power supplied by the battery.

When the power supply voltage rises to a level greater than or equal to  $V_{INH}$ , the PMOS transistor between the input/output pins turns on and the power for such devices is supplied from the  $V_{IN}$  pin. At the same time, the primary battery voltage detection and the secondary battery recharging operations are actuated.

#### (2) Standby mode

When the power supply voltage rises to a level greater than or equal to  $V_{INH}$ , the  $RESET$  pin outputs a High level for the set duration of time and the devices such as SRAM or a microprocessor are held in the standby mode. Note that the set duration of time can be adjusted by changing the capacitance of the  $C_T$  pin.

The  $\overline{RESET}$  pin outputs an inverted signal of the  $RESET$  pin.

#### (3) Active mode

The reset signal is cleared and the devices such as SRAM or a microprocessor are placed in the operating mode.

## (4) Momentary power failure or voltage dip

When the power supply voltage drops less than or equal to  $V_{INL}$  (4.2 V Typ) as the power supply goes down or its voltage dips momentarily, the RESET pin outputs a High level and the  $\overline{\text{RESET}}$  pin outputs a low level. The devices such as SRAM or a microprocessor are thereby placed in the standby mode and powered from the battery. When in this mode, the primary battery voltage detection and the secondary battery recharging operations are stopped.

Note: To guarantee backup operation in case of momentary power failure, make sure the 5 V-to-0 V fall time on  $V_{IN}$  is 50  $\mu\text{s}$  or more by using, for example, a capacitor.

## 2. Alarm Operation

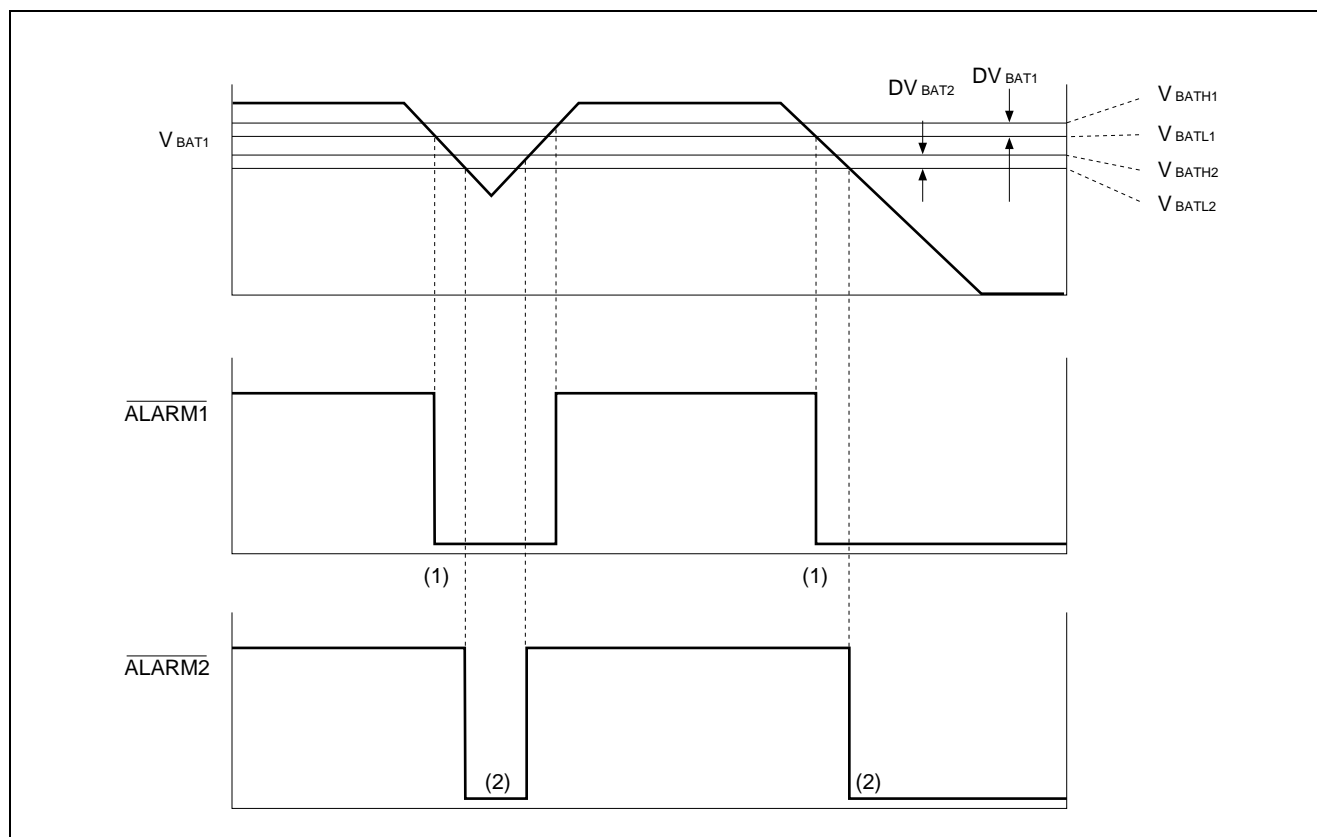

If the primary battery voltage decreases while the power supply voltage ( $V_{IN}$ ) is greater than or equal to  $V_{INH}$  (4.3 V Typ), alarm signals are output as described below. At this time, if the  $V_{BAT1}$  pin is released open, the output from the alarm pin becomes indeterminate.

### (1) Primary battery replacement alarm (alarm-1 output)

If the primary battery voltage drops to  $V_{BAT1}$  (2.65 V Typ), the  $\overline{\text{ALARM1}}$  pin is forced to a Low level to issue an alarm indicating that it's time to replace the primary battery.

### (2) Primary battery minimum voltage alarm (alarm-2 output)

If the primary battery voltage further drops to  $V_{BAT2}$  (2.37 V Typ), the  $\overline{\text{ALARM2}}$  pin is forced to a Low level to issue an alarm indicating that the primary battery power has dropped below the voltage necessary to retain the SRAM data (approx. 2.0 V).

## ■ ABSOLUTE MAXIMUM RATINGS

(Ta = +25°C)

Parameter	Symbol	Conditions	Rating		Unit	
			Min	Max		
Input voltage	V <sub>IN</sub>	—	-0.3	6	V	
Battery voltage	V <sub>BAT</sub>		-0.3	6	V	
Reset output Voltage	V <sub>RESET</sub>		-0.3	V <sub>OUT</sub> + 0.3 (≤ 6)	V	
Alarm output Voltage	V <sub>ALARM</sub>		-0.3	V <sub>IN</sub> + 0.3 (≤ 6)	V	
Output current	I <sub>OUT</sub>		—	250	mA	
Output high current	I <sub>OH</sub>	Source current	—	6	mA	
Output low current	I <sub>OL</sub>	Sink current	—	6	mA	
Power dissipation	P <sub>D</sub>	Ta ≤ +25°C	TSSOP	—	450*	mW
			SOP	—	540*	mW
Storage temperature	T <sub>stg</sub>	—	-55	+125	°C	

\* : When mounted on a 4 cm-square double-side epoxy board.

**WARNING:** Semiconductor devices can be permanently damaged by application of stress (voltage, current, temperature, etc.) in excess of absolute maximum ratings. Do not exceed these ratings.

## ■ RECOMMENDED OPERATING CONDITIONS

Parameter	Symbol	Conditions	Value			Unit
			Min	Typ	Max	
Input voltage	V <sub>IN</sub>	—	—	5.0	5.5	V
Battery voltage	V <sub>BAT</sub>		—	3.0	3.3	V
Output current	I <sub>OUT</sub>		0	—	200	mA
Output current during battery backup	I <sub>O(BAT1)</sub>	Supply from the primary battery	—	—	500	μA
	I <sub>O(BAT2)</sub>	Supply from the secondary battery	—	—	50	
Operating temperature	T <sub>op</sub>	—	-30	—	+70	°C

**WARNING:** The recommended operating conditions are required in order to ensure the normal operation of the semiconductor device. All of the device's electrical characteristics are warranted when the device is operated within these ranges.

Always use semiconductor devices within their recommended operating condition ranges. Operation outside these ranges may adversely affect reliability and could result in device failure.

No warranty is made with respect to uses, operating conditions, or combinations not represented on the data sheet. Users considering application outside the listed conditions are advised to contact their FUJITSU representatives beforehand.





## ■ ELECTRICAL CHARACTERISTICS

### • DC characteristics

(Recommended operating conditions unless otherwise noted.)





( $V_{IN} = +5\text{ V}$ ,  $T_a = +25^\circ\text{C}$ )

Parameter	Symbol	Conditions	Value			Unit	
			Min	Typ	Max		
All sections	Input current	$I_{IN1}$	$I_{OUT} = 0\text{ mA}$	—	50	100	$\mu\text{A}$
Backup Power Supply Section	Input/output voltage difference	$DV_1$	$I_{OUT} = 1\text{ mA}$	—	0.5	10	mV
		$DV_2$	$I_{OUT} = 200\text{ mA}$	—	100	300	mV
	Output delay time	$t_{ro}$	$C_o = 0.01\ \mu\text{F}$ , $C_T = 0$	—	2.0	10	$\mu\text{s}$
Power Supply Monitoring Section	Input low voltage detection	$V_{INL}$	$V_{IN}$ 	4.10	4.20	4.30	V
			$T_a = -30^\circ\text{C}$ to $+70^\circ\text{C}$	4.05	4.20	4.35	V
		$V_{INH}$	$V_{IN}$ 	4.20	4.30	4.40	V
			$T_a = -30^\circ\text{C}$ to $+70^\circ\text{C}$	4.15	4.30	4.45	V
	Input low voltage hysteresis width	$DV_{IN}$	$V_{INH} - V_{INL}$	50	100	150	mV
	Reset output voltage	$V_{OHR}$	$I_{OHR} = 1\text{ mA}$	4.5	4.8	—	V
		$V_{OLR}$	$I_{OLR} = 5\text{ mA}$	—	0.2	0.4	V
	Reset output voltage during backup $V_{IN} = 0\text{ V}$ $V_{BAT1} = 3\text{ V}$	$V_{OHR}$	$I_{OHR} = 0.2\text{ mA}$	2.2	2.6	—	V
		$V_{OLR}$	$I_{OLR} = 3\text{ mA}$	—	0.2	0.4	V
	Reset pulse width	$t_{PO}$	$C_T = 1000\text{ pF}$	0.5	1.0	2.0	ms
	Input pulse width	$t_{PI}$		5.0	—	—	$\mu\text{s}$
	Reset output rise time	$t_{rR}$	$C_T = 1000\text{ pF}$	—	2.0	3.0	$\mu\text{s}$
	Reset output fall time	$t_{fR}$	$C_L = 100\text{ pF}$	—	0.2	1.0	$\mu\text{s}$
Reset output delay time	$t_{pdR}$	$V_{IN}$ slew rate $< 0.1\text{ V}/\mu\text{s}$	—	2.0	10	$\mu\text{s}$	

(Continued)

(Continued)

( $V_{IN} = +5\text{ V}$ ,  $T_a = +25^\circ\text{C}$ )

Parameter	Symbol	Conditions	Value			Unit	
			Min	Typ	Max		
Battery-1 Monitoring Section	$V_{BATL1}$	$V_{BAT}$ 	2.55	2.65	2.75	V	
		$T_a = -30^\circ\text{C to } +70^\circ\text{C}$	2.52	2.65	2.78	V	
		$V_{BATH1}$ 	2.59	2.69	2.79	V	
		$T_a = -30^\circ\text{C to } +70^\circ\text{C}$	2.56	2.69	2.82	V	
	Low voltage detection-1 hysteresis width	$DV_{BAT1}$	$V_{BATH1} - V_{BATL1}$	20	40	60	mV
	Low voltage detection 2	$V_{BATL2}$	$V_{BAT}$ 	2.27	2.37	2.47	V
			$T_a = -30^\circ\text{C to } +70^\circ\text{C}$	2.24	2.37	2.50	V
		$V_{BATH2}$	$V_{BAT}$ 	2.31	2.41	2.51	V
			$T_a = -30^\circ\text{C to } +70^\circ\text{C}$	2.28	2.41	2.54	V
	Low voltage detection-2 hysteresis width	$DV_{BAT2}$	$V_{BATH2} - V_{BATL2}$	20	40	60	mV
	Low voltage detection difference	$DV_{BAT}$	$V_{BATL1} - V_{BATL2}$	0.26	0.28	0.30	V
	Battery-1 input current	$I_{BATA}$	$V_{BAT} = 3\text{ V}$ , $V_{IN} = 0\text{ V}$	-100	—	500	nA
		$I_{BATB}$	$V_{BAT} = 3\text{ V}$ , $V_{IN} = 5\text{ V}$	-100	—	500	nA
	Battery-1 output voltage difference during backup, CTL = GND	$DV_{B1}$	$I_{BAT1} = 100\ \mu\text{A}$	—	0.30	0.35	V
$I_{BAT1} = 10\ \mu\text{A}$			—	0.10	0.15	V	
Alarm output voltage	$V_{OHA}$	$I_{OHA} = 4\text{ mA}$	4.5	4.8	—	V	
	$V_{OLA}$	$I_{OLA} = 5\text{ mA}$	—	0.2	0.4	V	
Alarm output rise time	$t_{rA}$	$C_L = 100\text{ pF}$	—	2.0	3.0	$\mu\text{s}$	
Alarm output fall time	$t_{fA}$		—	0.2	1.0	$\mu\text{s}$	
Alarm output delay time	$t_{pdA}$	50 mV overdrive	—	2.0	10	$\mu\text{s}$	
Battery-2 Monitoring Section	Battery-2 recharging voltage	$V_{CHG}$	$I_{CHG} = -10\ \mu\text{A}$	2.80	3.00	3.20	V
	Battery-2 recharging current	$I_{CHG}$	$V_{CHG} = 2.0\text{ V}$	1.0	2.0	—	mA
	Battery-2 output voltage difference during backup	$DV_{B2}$	$I_{BAT2} = 10\ \mu\text{A}$	—	0.10	0.15	V

## ■ TIMING CHART

### 1. Rise/Fall Times on Reset and Alarm Pins: $t_r/t_f$

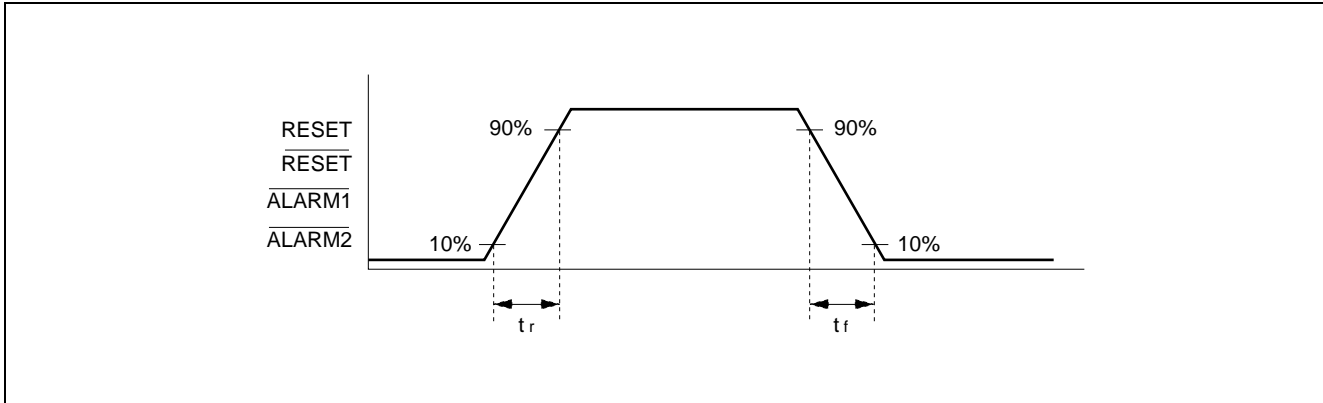

### 2. Reset Pulse Width: $t_{PO}$ ; Input Pulse Width: $t_{PI}$ ; Reset Output Delay Time: $t_{pdR}$

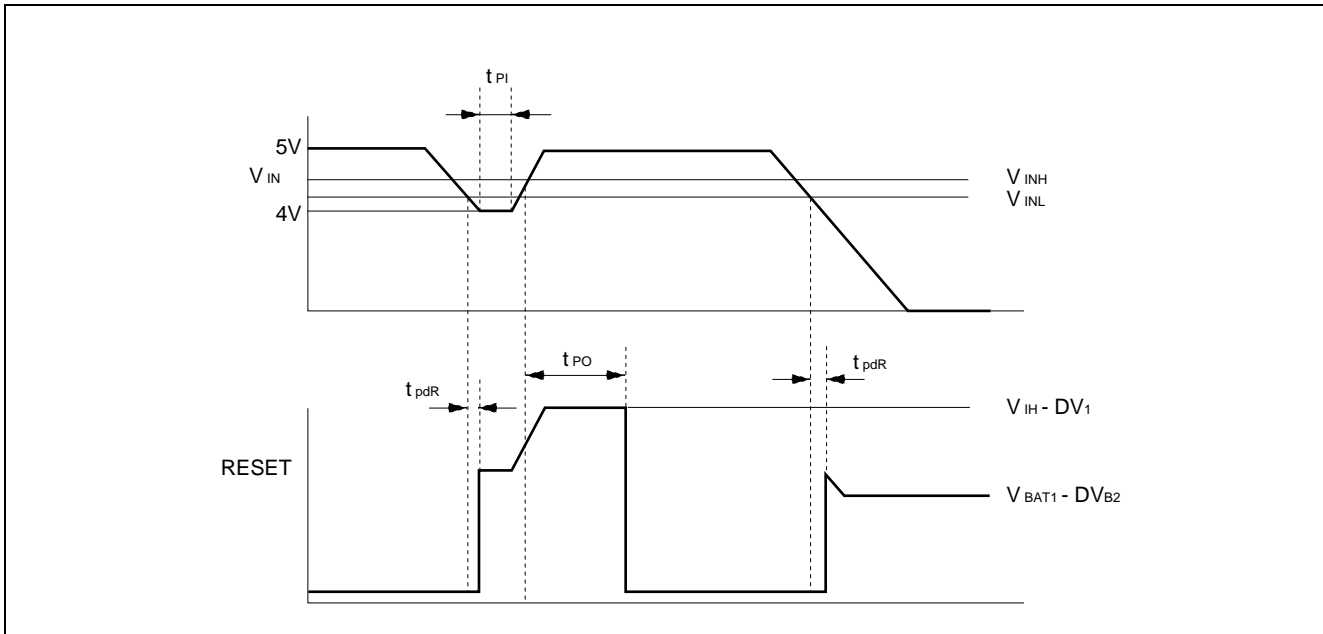

### 3. Alarm Output delay time: $t_{pdA}$

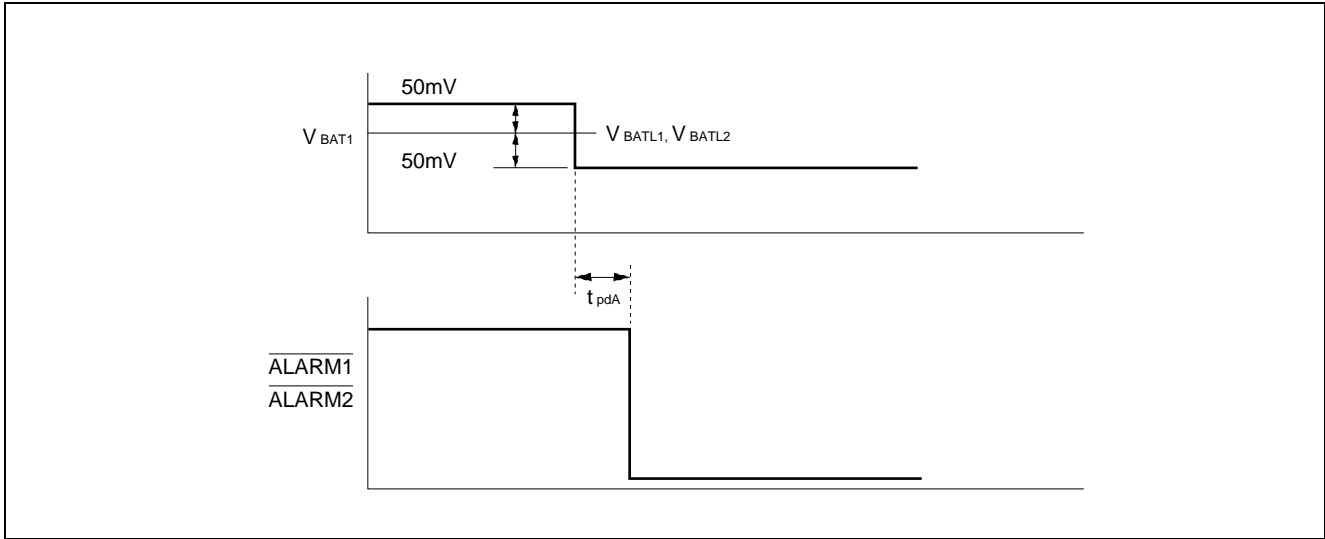

### 4. $V_{OUT}$ Output Delay Time: $t_{ro}$

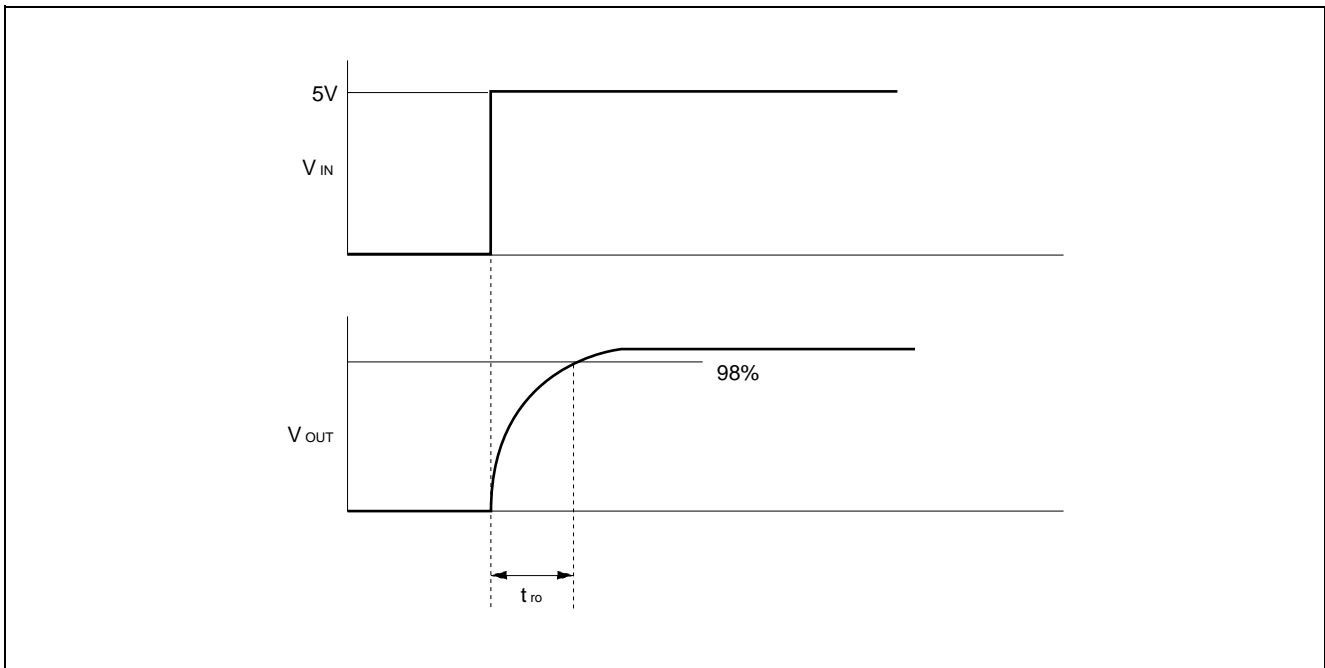

## TYPICAL CHARACTERISTIC CURVES

1.  $V_{OH}$  characteristics of RESET pin

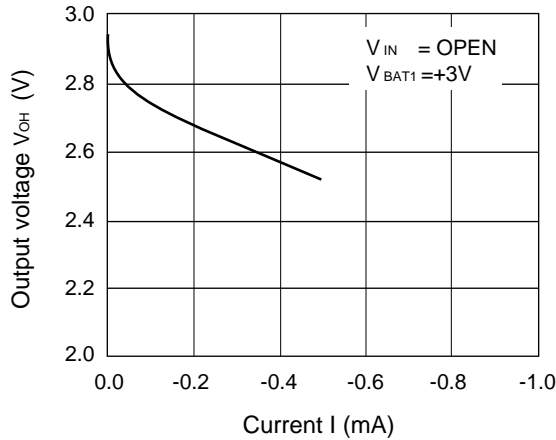

2.  $V_{OL}$  characteristics of RESET pin

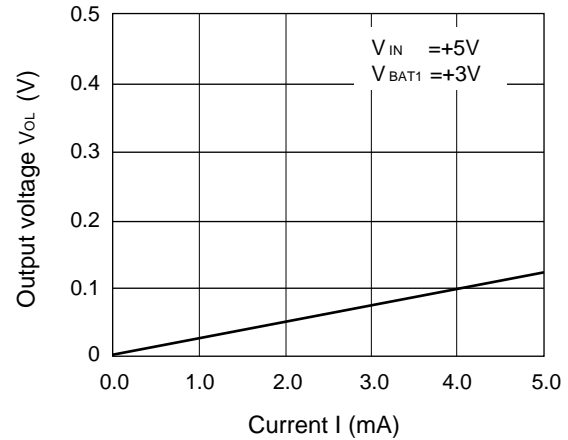

3.  $V_{OH}$  characteristics of  $\overline{\text{RESET}}$  pin

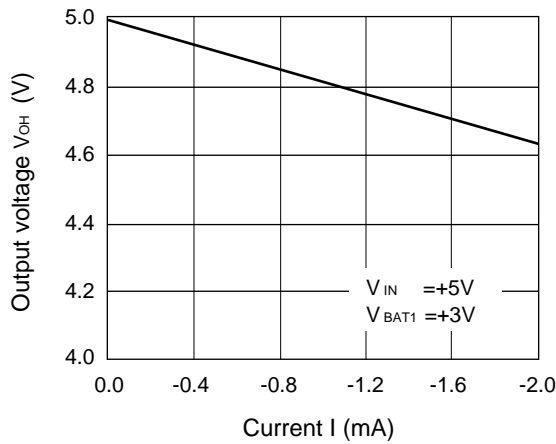

4.  $V_{OL}$  characteristics of  $\overline{\text{RESET}}$  pin

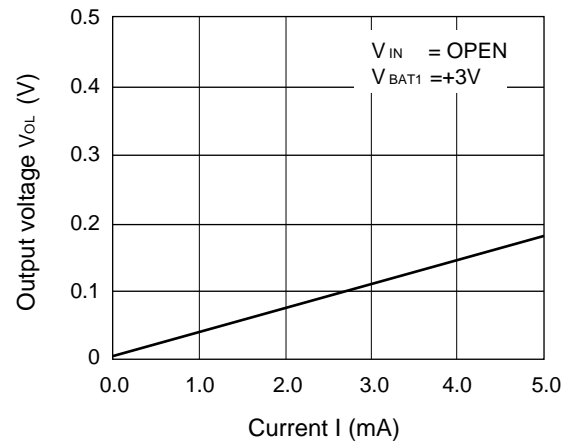

5.  $V_{OH}$  characteristics of  $\overline{\text{ALM}}$  pin

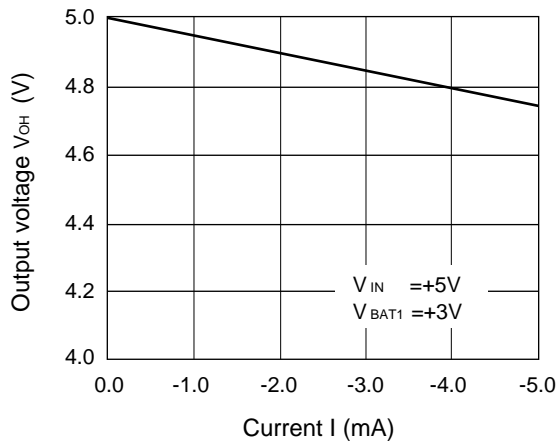

6.  $V_{OL}$  characteristics of  $\overline{\text{ALM}}$  pin

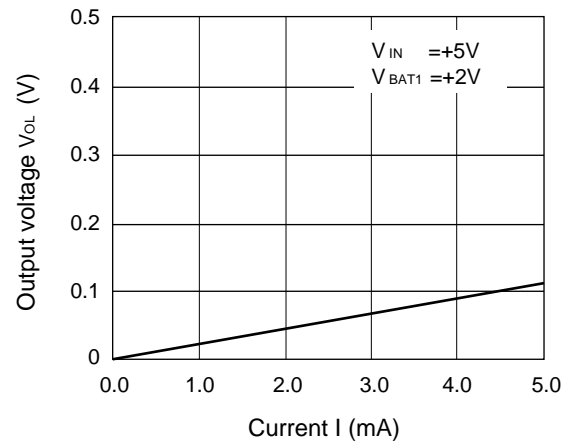

(Continued)

(Continued)

7. Temperature characteristics of input current

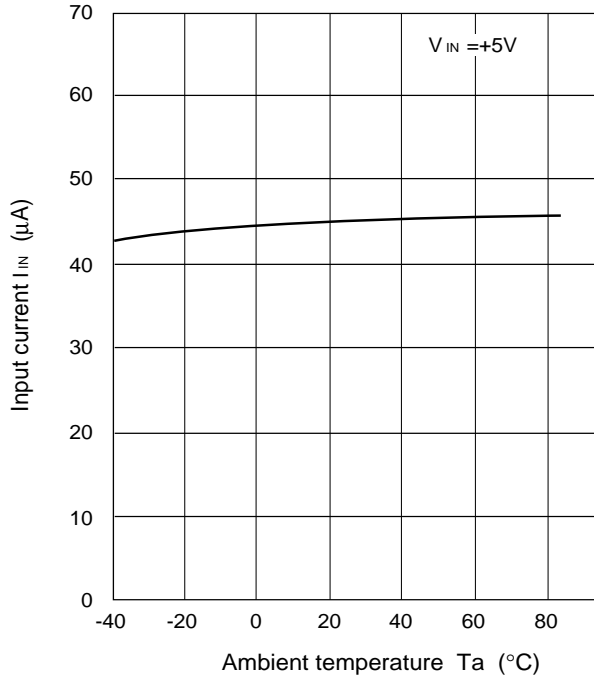

8. Temperature characteristics of battery power detection voltage

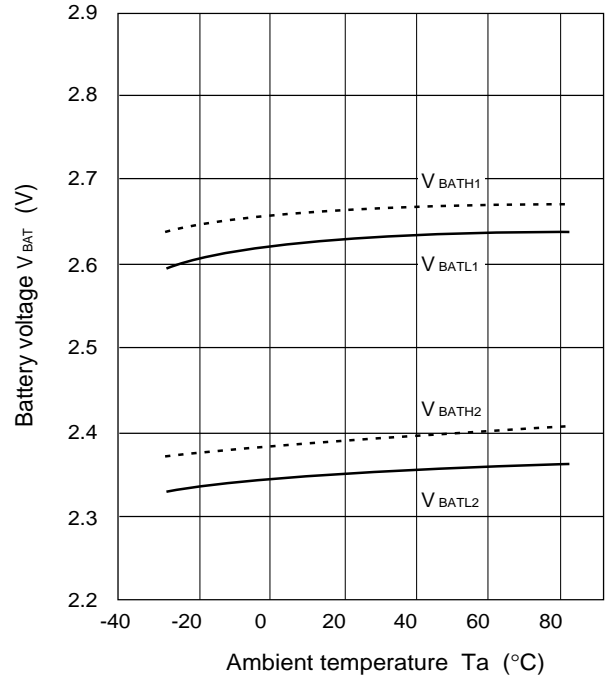

9. Temperature characteristics of power-down detection voltage

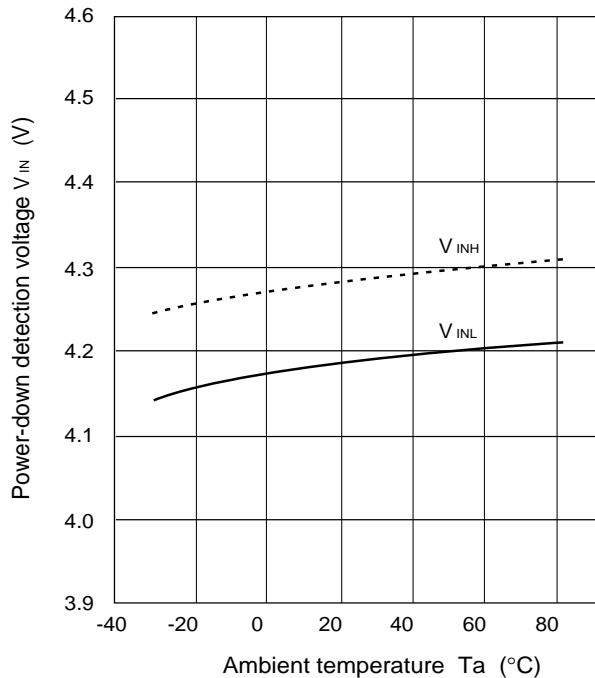

## ■ APPLICATION

### 1. Method of Using the CONTROL Pin

It is possible to control the operation of analog switch 1 by entering a High or Low level to the CONTROL pin while being powered by the battery. The Table below shows how the analog switch operates when its operation is controlled from the CONTROL pin.

When using the primary and the secondary batteries in combination as in the case of memory cards, be sure to set the CONTROL pin High to prevent the primary battery from being recharged by the secondary battery current flowing from analog switch 1.

- Control Conditions of CONTROL Pin

Operating state	Control conditions		ON/OFF State of analog switch*2	
	Input voltage ( $V_{IN}$ )	CONTROL pin*1	Analog switch 1	Analog switch 2
Standby/active state	$V_{IN} > V_{INL}$	High/Low	OFF	OFF
Backup state	$V_{INL} > V_{IN}$	High (= $V_{OUT}$ )	OFF	ON
	$V_{INL} > V_{IN}$	Low (= GND)	ON	ON

\*1: If the CONTROL pin is released open, the logic state of the CMOS circuit may become instable letting current flow into the circuit. Therefore, the CONTROL pin must always have a High or Low level input.

\*2: The ON-resistance of the analog switch is approximately 10 k $\Omega$ .

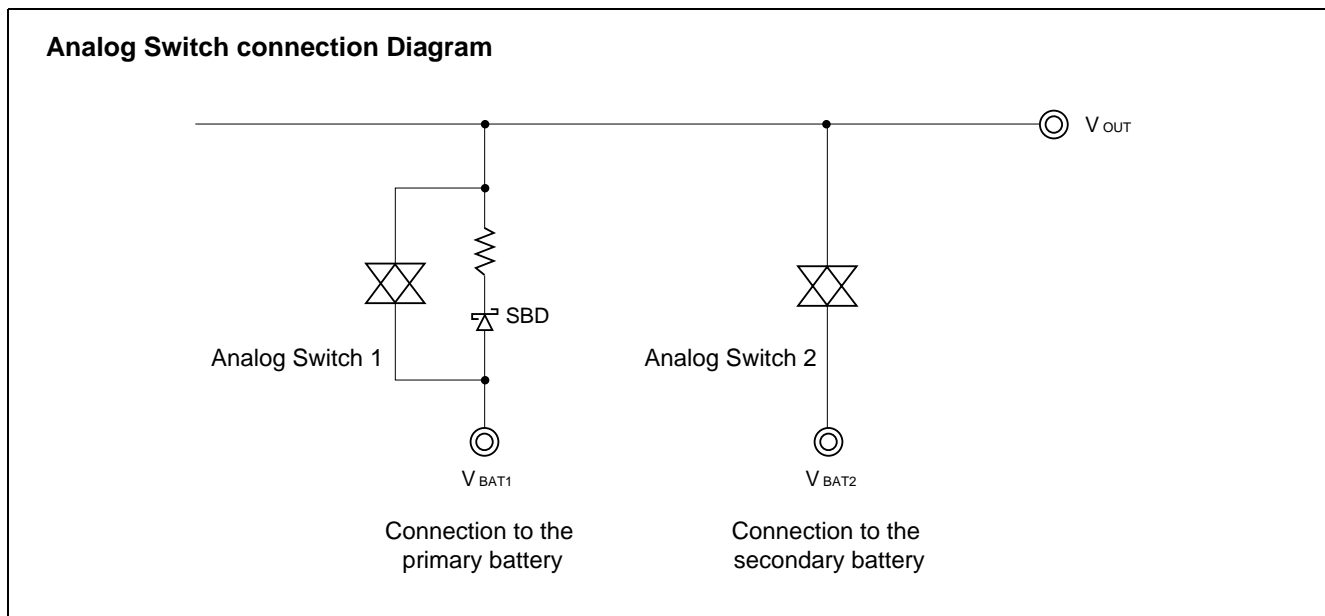

### 3. Outputting Reset Signal Forcibly

The reset signal can be output forcibly by bringing the  $V_{SENSE}$  pin of the MB3790 to a Low level ( $< 1.24$ ). The reset signal is held on until the capacitor  $C_T$  is charged up after the  $V_{SENSE}$  pin is released open.

#### Forced Reset Method 1

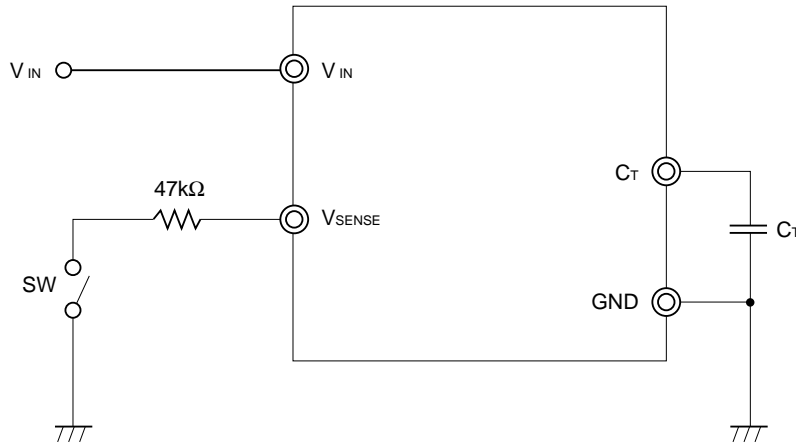

SW: Turned on ( $V_{RESET} = \text{High}$ )

#### Forced Reset Method 2

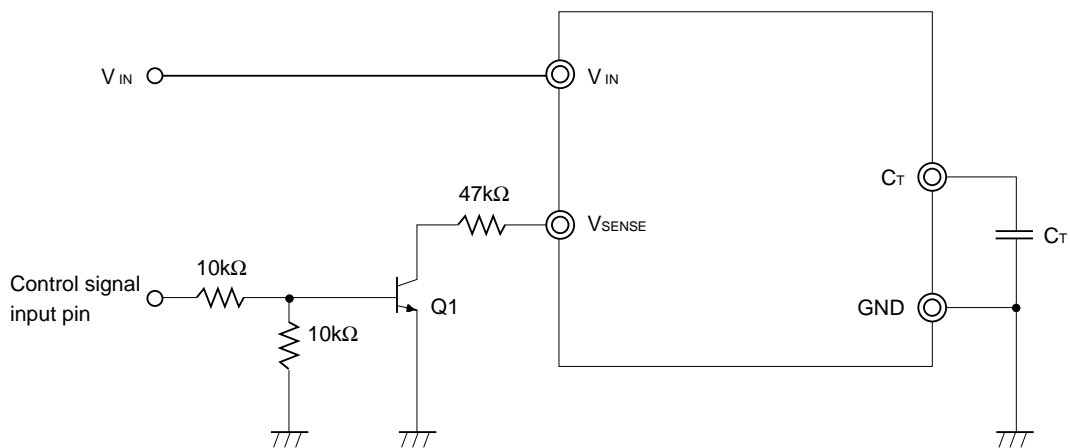

When the voltage enough to turn on Q1 ( $\geq$  approx. 1.2 V) gives to the Control signal input pin,  $V_{RESET}$  is equal to High level.

#### [Reset Pulse Width Calculation Formula]

Reset Pulse Width  $t_{PO}$  (s) =  $C_T$  (F)  $\times 10^6$  (where  $C_T$  = capacitance)

Example: When  $C_T = 1000$  pF,  $t_{PO} = 1$  ms (Typ)



## 4. Adjusting the Supply Voltage Detection Level Set time

The MB3790 outputs a reset signal when the power supply momentarily goes down or its voltage sags for 5  $\mu$ s or more. The set time before this reset signal is output can be extended by connecting a capacitor to the  $V_{SENSE}$  pin.

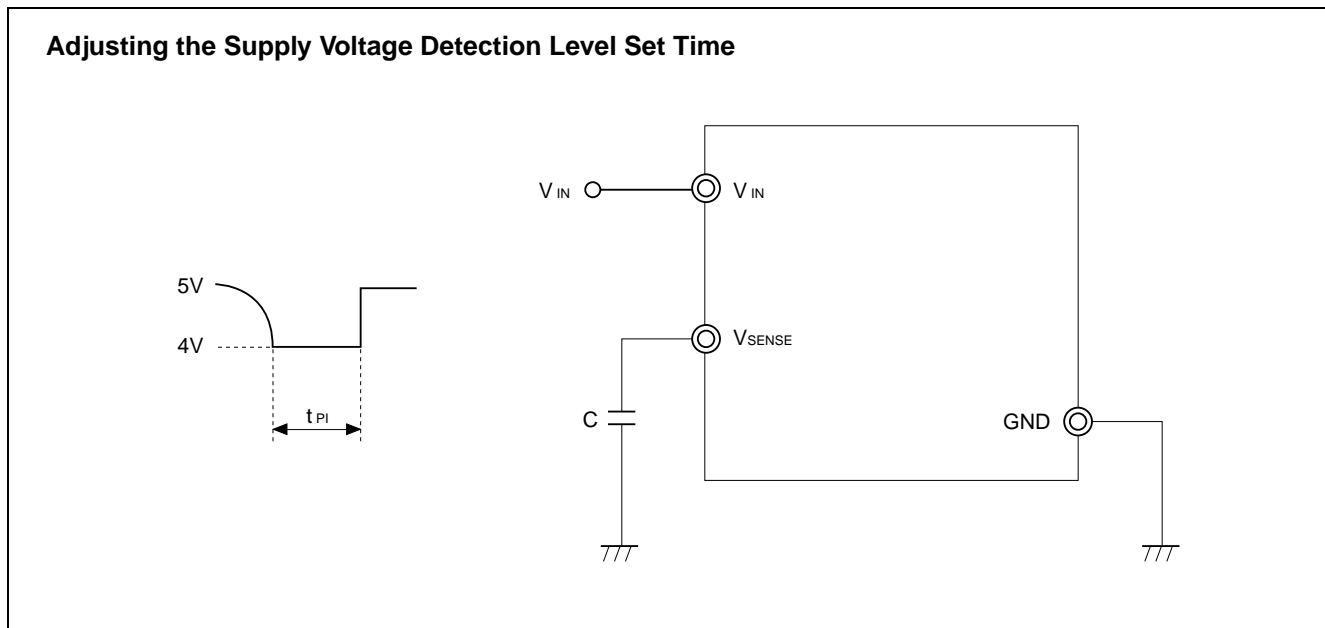

## 5. Compatibility with JEIDA Memory Card Guideline Ver. 4

The MB3790 has its  $\overline{ALM1}$  and  $\overline{ALM2}$  pin specifications matched to the BVD2 and BVD1 pin specifications of the JEIDA Memory Card Guideline Ver. 4. Therefore, the  $\overline{ALM1}$  and  $\overline{ALM2}$  pins can be connected directly to the BVD2 and BVD1 pins.

- Alarm Pin Detection Voltage Levels

Pin Name	$V_{BAT1} \leq 2.37\text{ V}$	$2.37\text{ V} < V_{BAT1} \leq 2.65\text{ V}$	$2.65\text{ V} \leq V_{BAT1}$	Connected Pin
$\overline{ALM1}$	Low level	Low level	High level	BVD2
$\overline{ALM2}$	Low level	High level	High level	BVD1

$V_{BAT1}$ : Primary battery voltage

## ■ STANDARD DEVICE CONFIGURATION

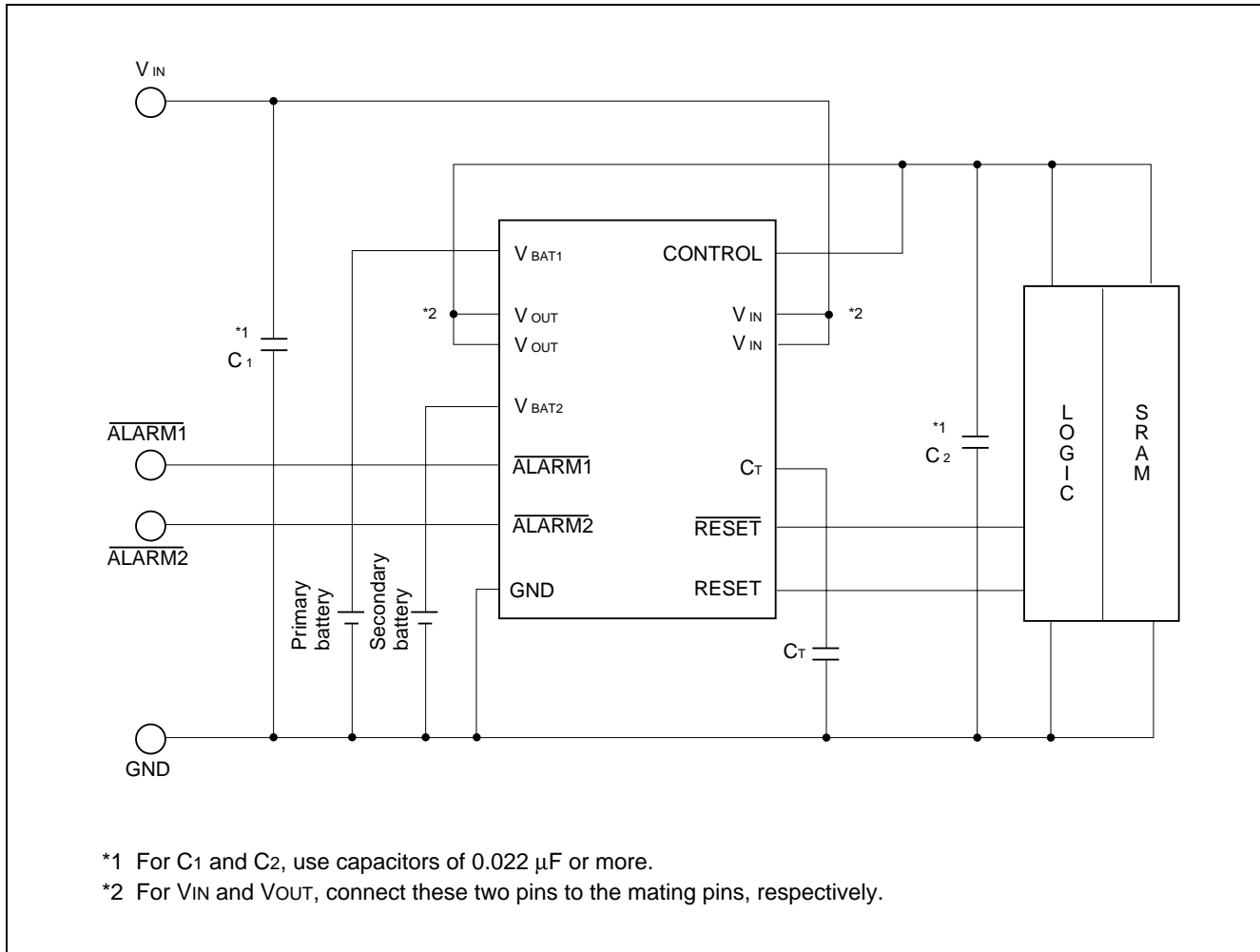

## ■ NOTES ON USE

- Take account of common impedance when designing the earth line on a printed wiring board.
- Take measures against static electricity.
  - For semiconductors, use antistatic or conductive containers.
  - When storing or carrying a printed circuit board after chip mounting, put it in a conductive bag or container.
  - The work table, tools and measuring instruments must be grounded.
  - The worker must put on a grounding device containing 250 k $\Omega$  to 1 M $\Omega$  resistors in series.
- Do not apply a negative voltage
  - Applying a negative voltage of  $-0.3$  V or less to an LSI may generate a parasitic transistor, resulting in malfunction.

## ■ ORDERING INFORMATION

Part number	Package	Remarks
MB3790PF	16-pin Plastic SOP (FPT-16P-M06)	
MB3790PFT	20-pin Plastic TSSOP (FPT-20P-M04)	

# MB3790

## ■ PACKAGE DIMENSIONS

16-pin Plastic SOP  
(FPT-16P-M06)

Note 1) \*1 : These dimensions include resin protrusion.  
 Note 2) \*2 : These dimensions do not include resin protrusion.  
 Note 3) Pins width and pins thickness include plating thickness.  
 Note 4) Pins width do not include tie bar cutting remainder.

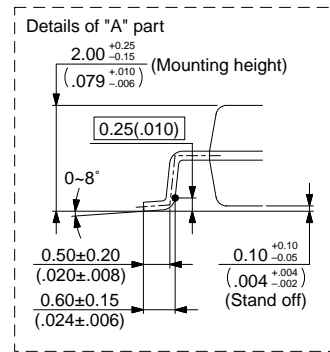
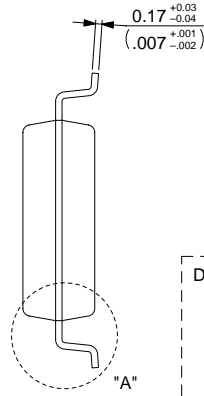
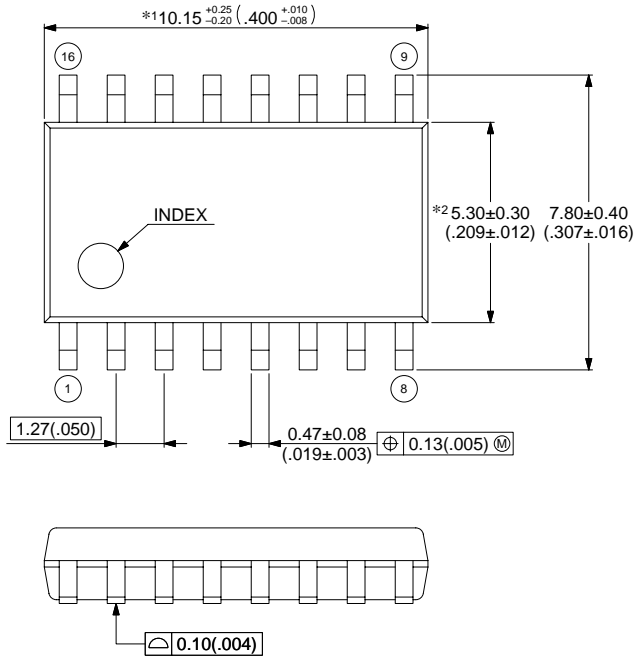

© 2002 FUJITSU LIMITED F16015S-c-4-7

Dimensions in mm (inches) .  
 Note : The values in parentheses are reference values.

(Continued)



## FUJITSU LIMITED

All Rights Reserved.

The contents of this document are subject to change without notice. Customers are advised to consult with FUJITSU sales representatives before ordering.

The information, such as descriptions of function and application circuit examples, in this document are presented solely for the purpose of reference to show examples of operations and uses of Fujitsu semiconductor device; Fujitsu does not warrant proper operation of the device with respect to use based on such information. When you develop equipment incorporating the device based on such information, you must assume any responsibility arising out of such use of the information. Fujitsu assumes no liability for any damages whatsoever arising out of the use of the information.

Any information in this document, including descriptions of function and schematic diagrams, shall not be construed as license of the use or exercise of any intellectual property right, such as patent right or copyright, or any other right of Fujitsu or any third party or does Fujitsu warrant non-infringement of any third-party's intellectual property right or other right by using such information. Fujitsu assumes no liability for any infringement of the intellectual property rights or other rights of third parties which would result from the use of information contained herein.

The products described in this document are designed, developed and manufactured as contemplated for general use, including without limitation, ordinary industrial use, general office use, personal use, and household use, but are not designed, developed and manufactured as contemplated (1) for use accompanying fatal risks or dangers that, unless extremely high safety is secured, could have a serious effect to the public, and could lead directly to death, personal injury, severe physical damage or other loss (i.e., nuclear reaction control in nuclear facility, aircraft flight control, air traffic control, mass transport control, medical life support system, missile launch control in weapon system), or (2) for use requiring extremely high reliability (i.e., submersible repeater and artificial satellite).

Please note that Fujitsu will not be liable against you and/or any third party for any claims or damages arising in connection with above-mentioned uses of the products.

Any semiconductor devices have an inherent chance of failure. You must protect against injury, damage or loss from such failures by incorporating safety design measures into your facility and equipment such as redundancy, fire protection, and prevention of over-current levels and other abnormal operating conditions.

If any products described in this document represent goods or technologies subject to certain restrictions on export under the Foreign Exchange and Foreign Trade Law of Japan, the prior authorization by Japanese government will be required for export of those products from Japan.

F0308

© FUJITSU LIMITED Printed in Japan