

TOSHIBA Photo-IC Silicon Epitaxial Planar

TPS856

Mobile Phones

Notebook PCs, PDAs

Video cameras, Digital Still Cameras

Other Equipment Requiring Luminosity Adjustment

The TPS856 is an ultra-compact surface-mount photo-IC for illuminance sensors which incorporates a photodiode and current amp circuit in a single chip.

The sensitivity is superior to that of a phototransistor, and exhibits little variation.

It has spectral sensitivity closer to luminous efficiency and excellent output linearity.

With its ultra-compact surface-mount package, this photo-IC can be used as the power-saving control for domestic appliances or for backlighting for displays in cellular phones, this device enables low power consumption to be achieved.

This device includes stand-by function which can reduce the power consumption.

- Ultra-compact and light surface-mount package: $1.6 \times 1.6 \times 0.55$ mm
- Excellent output linearity of illuminance
- Little fluctuation in light current and high level of sensitivity
 - : $I_L = 57 \mu\text{A}$ (typ.) @ $E_V = 100$ lx using fluorescent light
 - : Light current variation width: $\times 1.67$ (When light current classification is specified.)
 - : Little temperature fluctuation
- Built-in luminous-efficiency correction function, reduced sensitivity variations due to various light sources
 - : I_L (using incandescent light)/ I_L (using fluorescent light) = 1.0 (typ.)
- Low supply voltage, making device suitable for battery-powered equipment: $V_{CC} = 1.8$ V to 5.5 V
- Lead(Pb)-Free

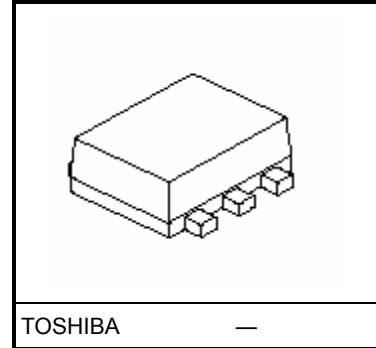

Weight: 0.003 g (typ.)

Absolute Maximum Ratings (Ta = 25°C)

Characteristics	Symbol	Rating	Unit
Supply voltage	V_{CC}	-0.5 to 6	V
Stand-by voltage	V_{stb}	$\leq V_{CC}$	V
Output voltage	V_{OUT}	$\leq V_{stb}$	V
Light current	I_L	5	mA
Permissible power dissipation	P	30	mW
Power dissipation derating (Ta > 25°C)	$\Delta P/^\circ\text{C}$	-0.4	mW/°C
Operating temperature range	T_{opr}	-30 to 85	°C
Storage temperature range	T_{stg}	-40 to 100	°C
Soldering temperature range (Note 1)	T_{sol}	260	°C

Note: Using continuously under heavy loads (e.g. the application of high temperature/current/voltage and the significant change in temperature, etc.) may cause this product to decrease in the reliability significantly even if the operating conditions (i.e. operating temperature/current/voltage, etc.) are within the absolute maximum ratings and the operating ranges.

Please design the appropriate reliability upon reviewing the Toshiba Semiconductor Reliability Handbook ("Handling Precautions"/"Derating Concept and Methods") and individual reliability data (i.e. reliability test report and estimated failure rate, etc).

Note 1: The reflow time and the recommended temperature profile are shown in the section entitled Handling Precautions.

Operating Ranges

Characteristics	Symbol	Min	Typ.	Max	Unit
Supply voltage	V_{CC}	1.8	—	5.5	V
Stand-by on voltage	V_{stbon}	1.8	—	V_{CC}	V
Stand-by off voltage	V_{stboff}	0	—	0.3	V

Electrical and Optical Characteristics (Ta = 25°C)

Characteristics	Symbol	Test Condition	Min	Typ.	Max	Unit
Supply voltage	V_{CC}	—	1.8	—	5.5	V
Supply current (1)	$I_{CC(1)}$	$V_{CC} = 3\text{ V}, V_{stb} = 3\text{ V}, E_V = 1000\text{ lx}$ (Note 2) (Note 5)	—	3.0	—	μA
Supply current (2)	$I_{CC(2)}$	$V_{CC} = 3\text{ V}, V_{stb} = 0.3\text{ V}, E_V = 1000\text{ lx}$ $R_L = 1\text{ k}\Omega$ (Note 2) (Note 5)	—	3.0	—	μA
Light current (1)	$I_L(1)$	$V_{CC} = 3\text{ V}, V_{stb} = 3\text{ V}, E_V = 100\text{ lx}$ (Note 2), (Note 4)	—	57	—	μA
Light current (2)	$I_L(2)$	$V_{CC} = 3\text{ V}, V_{stb} = 3\text{ V}, E_V = 10\text{ lx}$ (Note 3), (Note 4)	4.0	5.7	8.0	μA
Light current (3)	$I_L(3)$	$V_{CC} = 3\text{ V}, V_{stb} = 3\text{ V}, E_V = 100\text{ lx}$ (Note 3), (Note 4)	40	57	80	μA
Light current (4)	$I_L(4)$	$V_{CC} = 3\text{ V}, V_{stb} = 0.3\text{ V}, E_V = 100\text{ lx}$ (Note 3), (Note 4)	—	0.02	0.1	μA
Light current ratio	$\frac{I_L(1)}{I_L(3)}$	—	—	1.0	—	—
Dark current	I_{LEAK}	$V_{CC} = 3\text{ V}, V_{stb} = 3\text{ V}, E_V = 0$	—	—	0.1	μA
Saturation output voltage	V_O	$V_{CC} = 3\text{ V}, V_{stb} = 3\text{ V}, R_L = 150\text{ k}\Omega,$ $E_V = 100\text{ lx}$ (Note 3)	—	0.70	0.85	V
Waiting time	t_{wait}	$V_{CC} = 3\text{ V}, V_{stb} = 3\text{ V}, R_L = 150\text{ k}\Omega,$ $E_V = 5\text{ lx}$ (Note 3)	—	—	20	ms
Switching time	Rise time	t_r	—	70	—	μs
	Fall time	t_f	—	40	—	
	Delay time	t_d	—	100	—	
	Storage time	t_s	—	5	—	

Note 2: CIE standard A light source is used (color temperature = 2856K, approximated incandescence light).

Note 3: F10 of fluorescence light is used as light source. (color temperature = 5000K)

However, white LED is substituted in a mass-production process.

$I_L(3)$ classification A rank: 44.1 μA to 73.7 μA

Note 4: Light current measurement circuit

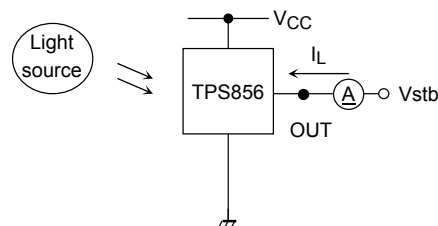

Note 5: Supply current measurement circuit

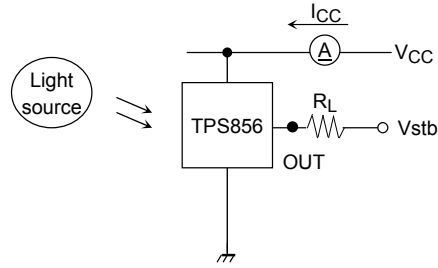

Note 6: Waiting time measurement method

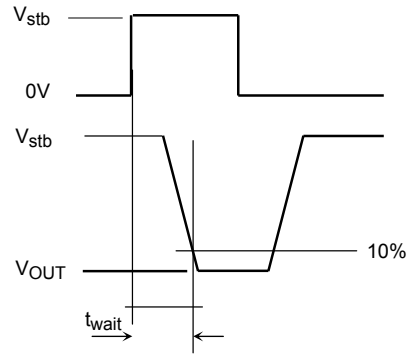
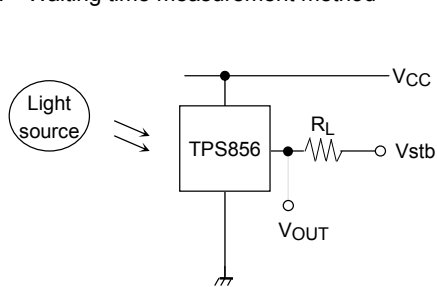

Note 7: Switching time measurement method

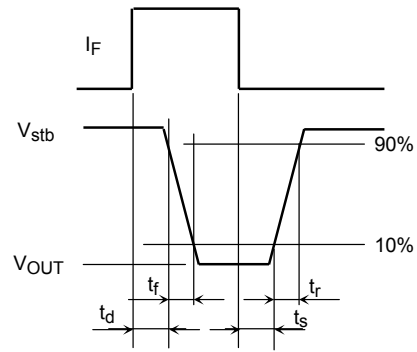
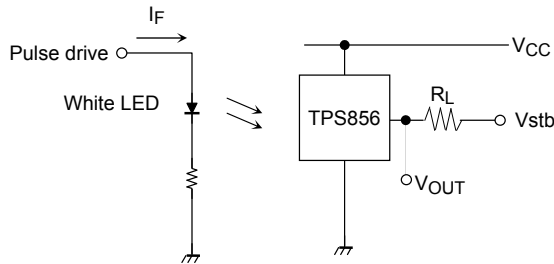

Package Dimensions

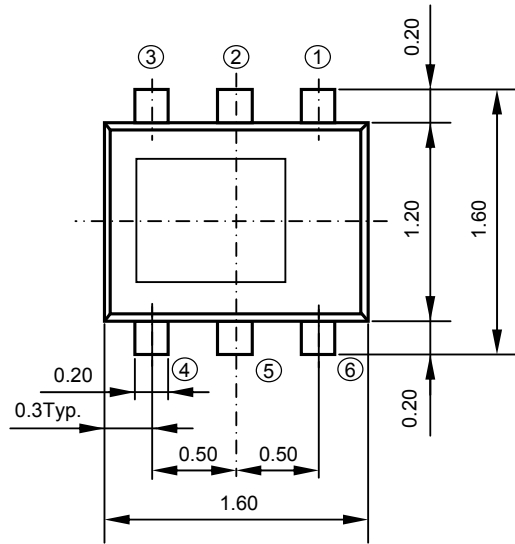

Unit: mm
 Tolerance: ± 0.1
 (): Reference value

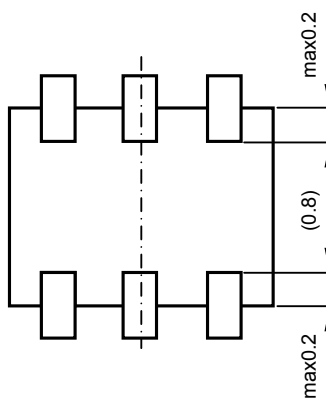
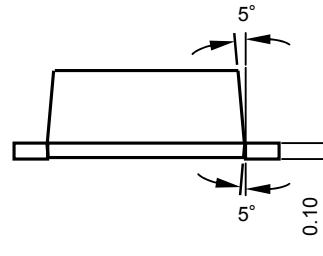
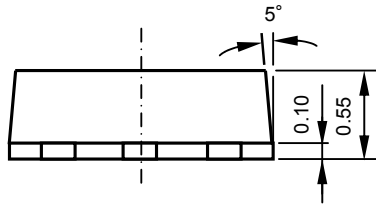

- Pin connection
1. V_{CC}
 2. GND
 3. GND
 4. GND
 5. GND
 6. OUT (V_{stb})

Weight: 0.003 g (typ.)

Block Diagram

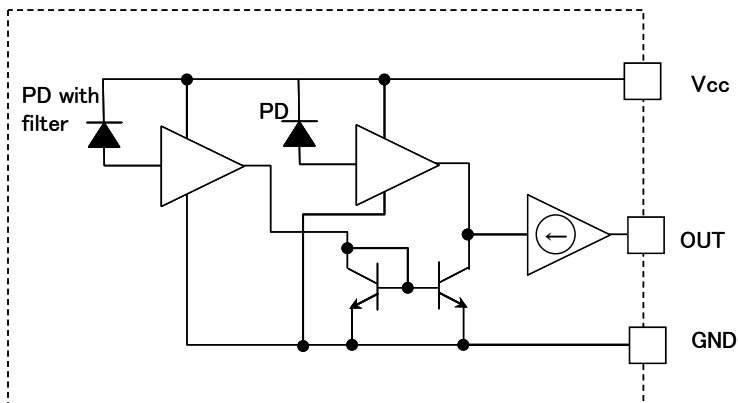

Equivalent circuit in output part

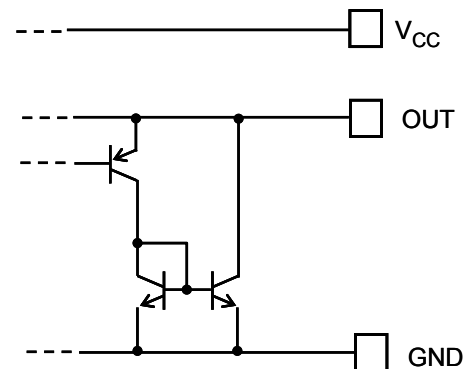

Handling Precautions

Insert a bypass condenser of up to 0.1 μ F between VCC and GND near the device to stabilize the power supply line.

Please put the bypass capacitor of 0.1 μ F between OUT and GND near the device if you use it as a current output (There is no load resistance).

When VCC is turned on it takes at least 20 ms for the internal circuit to stabilize. During this time the output signal is unstable. Please do not use the unstable signal as the output signal.

Moisture-Proof Packing

- (1) To avoid moisture absorption by the resin, the product is packed in an aluminum envelope with silica gel.
- (2) Since the optical characteristics of the device can be affected during soldering by vaporization resulting from prior absorption of moisture and they should therefore be stored under the following conditions:
Temperature: 5°C to 30°C, Relative humidity: 70% (max), Time: 168 h (max)
- (3) Baking in taping with reel is required if the devices have been store unopened for more than six months or if the aluminum envelope has been opened for more than 168 h.
These devices are packed on tapes; hence, please avoid baking at high temperature.
Recommended baking conditions: 60°C for 12 h or longer, Perform baking only once

Mounting Precautions

TPS856 uses a clear resin, and delicate handling is necessary for it.

The characteristic change or the product might be damaged by the handling method of mounting.

Please note the following and handle the product.

- (1) Do not apply stress to the resin at high temperature.
Time until the product returns at the normal temperature after mounting of the reflow is different according to the mounting substrate and the environment.
Please do not give the stress with heat remained in the product.
- (2) The resin part is easily scratched, so avoid friction with hard materials.
- (3) When installing the assembly board in equipment, ensure that this product does not come into contact with other components.
- (4) Please confirm the heat contraction of the substrate of the reflow mounting doesn't influence the product. The load is given to the product by mounting that the heat contraction is large on the substrate and the installation position of the substrate. Please note that the characteristic changes or the product might be damaged.

Mounting Methods

- (1) Example of reflow soldering

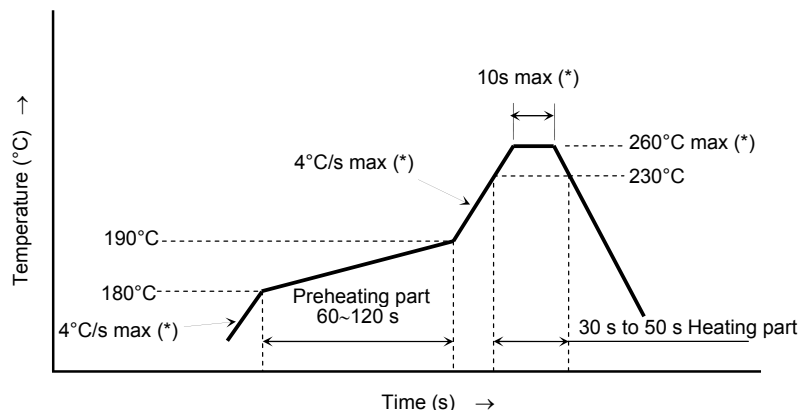

(*)The product is evaluated using above reflow soldering conditions. No additional test is performed exceed the condition (i.e. the condition more than MAX values) as an evaluation. Please perform reflow soldering under the above conditions. Perform reflow soldering no more than twice.

- Please perform the first reflow soldering within 168 h after opening the package with reference to the above temperature profile.

- Second reflow soldering
In case of second reflow soldering, it should be performed within 168 h after first reflow under the above conditions.
Storage conditions before second reflow soldering: 30°C, 70% RH or lower
- Do not perform flow soldering.
- Make any necessary soldering correction manually.
(Do not do this more than once for any given pin.)
Temperature: no more than 350°C (25 W for soldering iron)
Time: within 5 s

(2) Recommended soldering pattern

Unit: mm

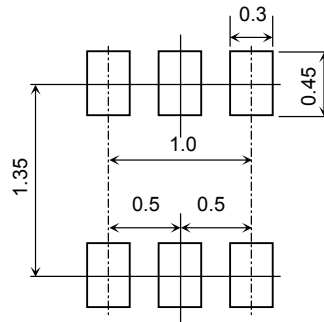

(3) Cleaning conditions

- When cleaning is required after soldering
Chemicals: AK225 alcohol
Temperature and time: 50°C × 30 s or 30°C × 3 min
Ultrasonic cleaning: 300 W or less

Packing Specification

(1) Packing quantity

Reel (minimum packing quantity)	3,000 devices
Carton	5 reels (15,000 devices)

(2) Packing format

- Silica gel and reel are packed into sealed aluminum envelope.
- Pack shock-absorbent materials around the aluminum envelopes in the cartons to cushion them.

- Carton specification

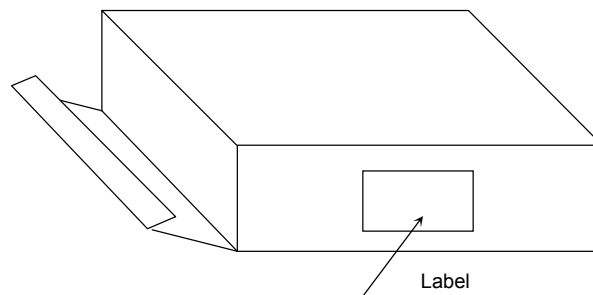

Carton dimensions
(W) 81 mm × (L) 280 mm × (H) 280 mm

Tape Packing Specifications

- (1) Reel dimensions
Reel material: Plastic

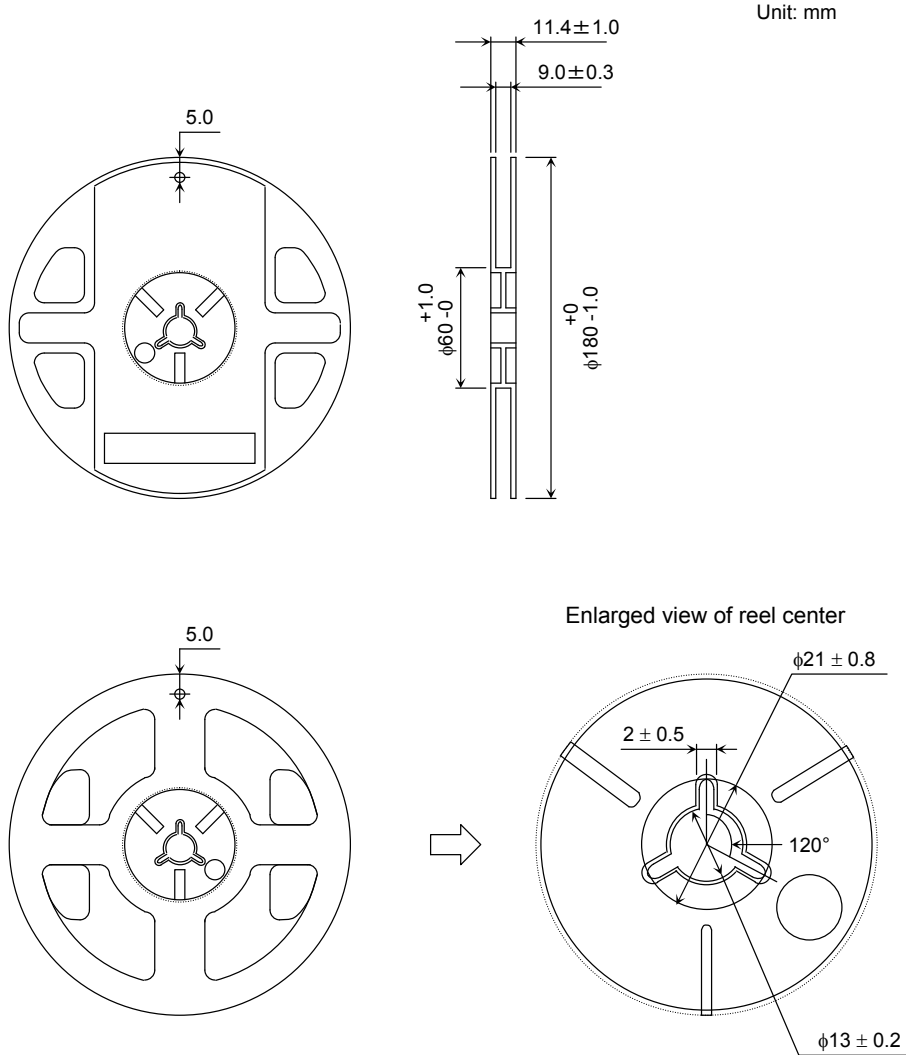

(2) Tape dimensions

Tape material: Plastic (anti-electrostatic)

Unit: mm

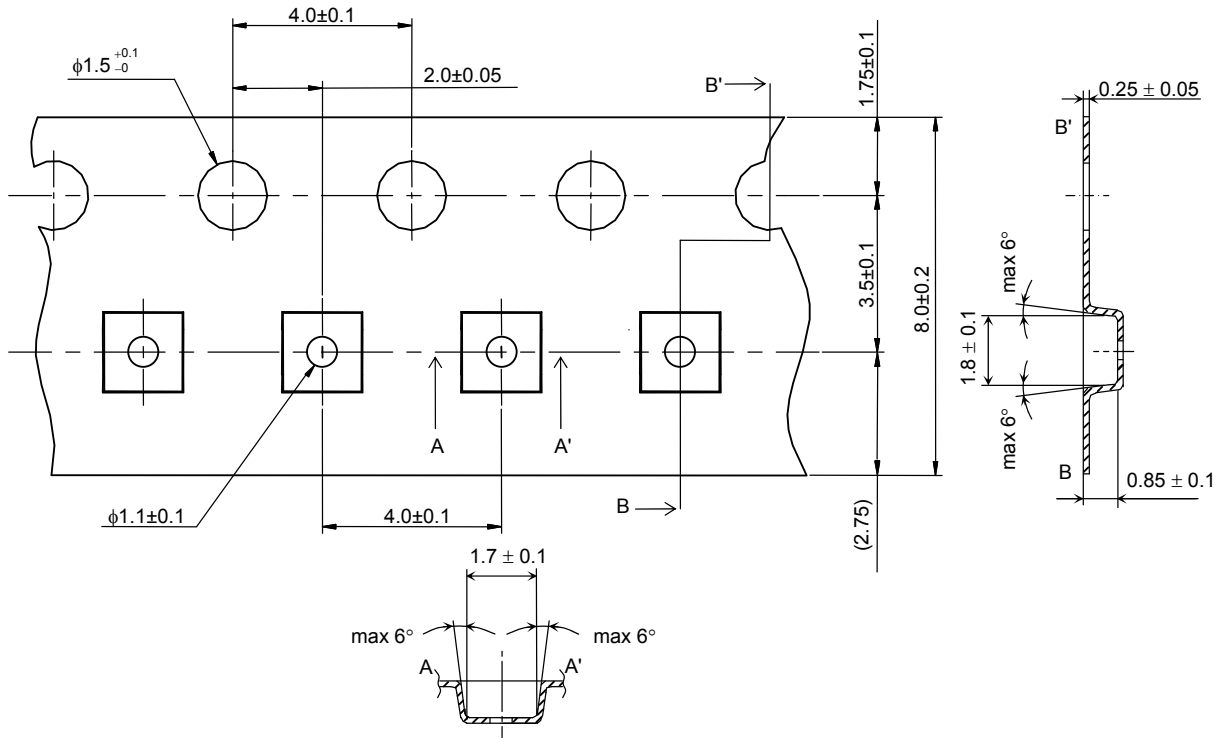

Product direction

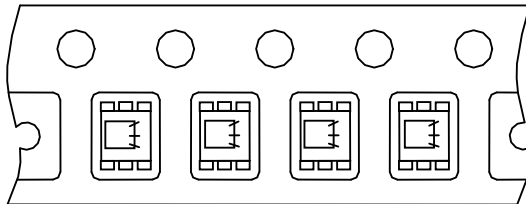

Reel Label

The label markings may include product number, quantity and seal date.

P/N			
TYPE	TPS856		
ADDC		Q'TY	3,000 pcs.
NOTE			

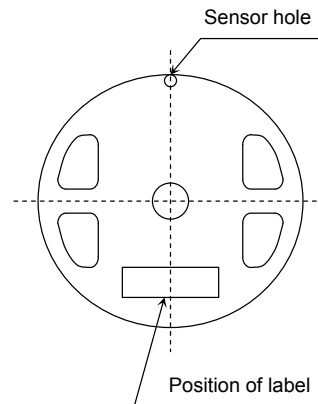

Leader and Trailer Sections of Tape

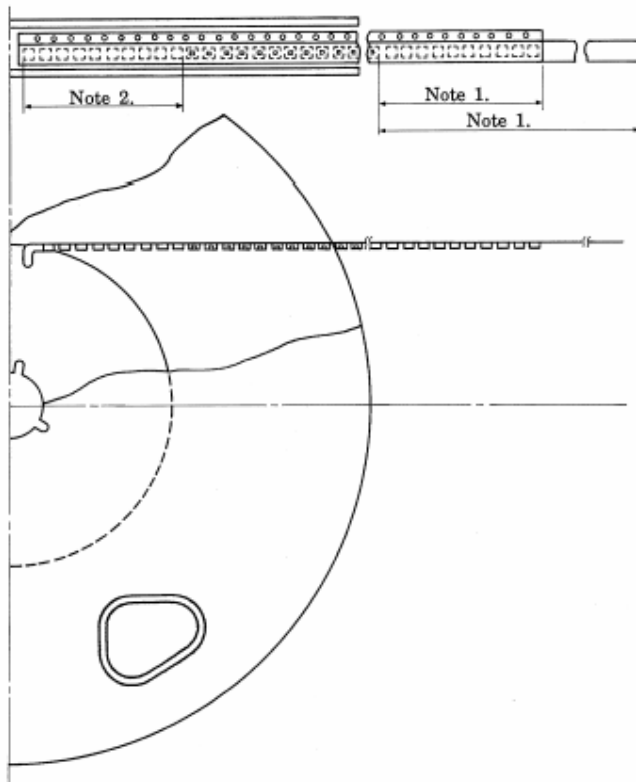

Note 1 : The leader portion shall consist of cover tape minimum length of 300 mm and a piece of carrier tape with empty portion of 100 mm minimum.

Note 2 : The trailer portion shall consist of empty carrier of more than 10 cavities.

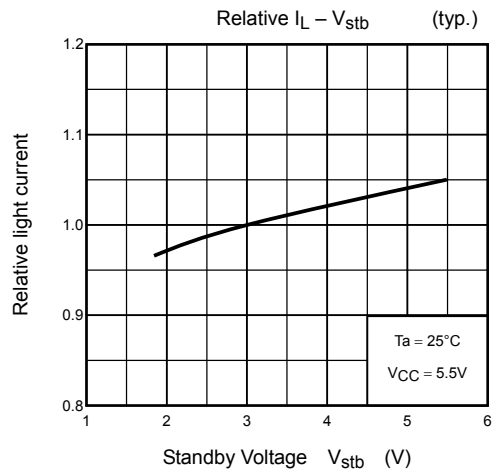
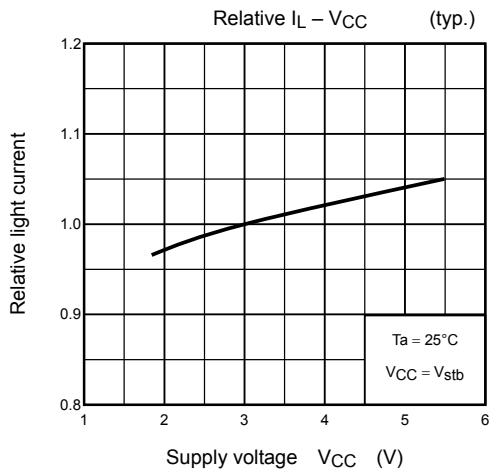
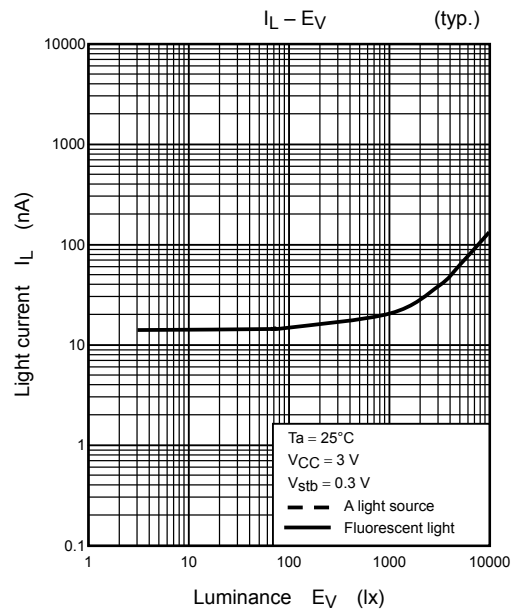
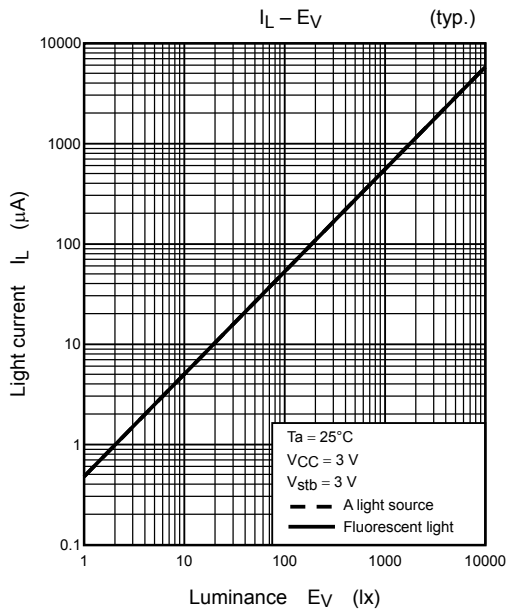
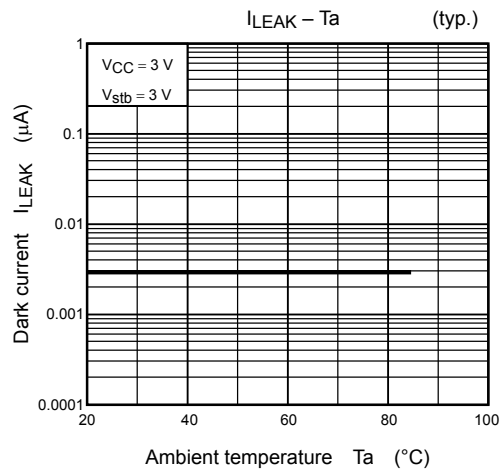
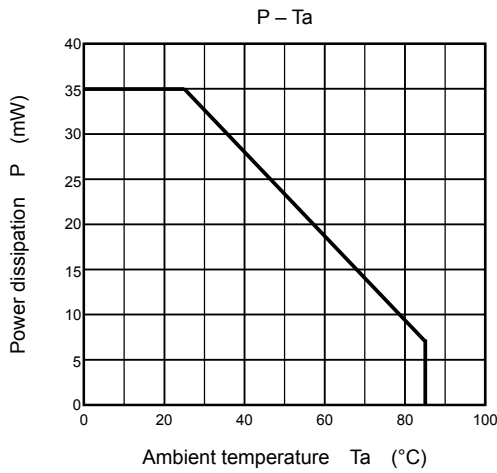

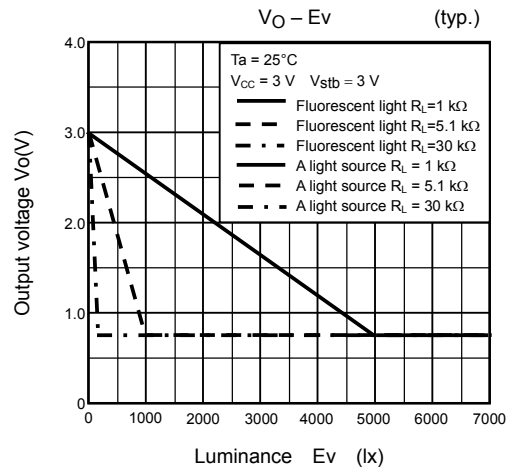
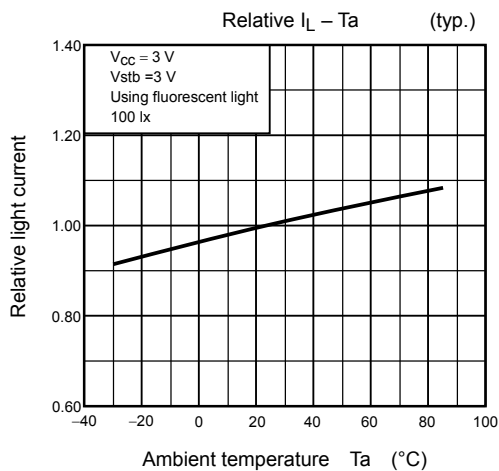
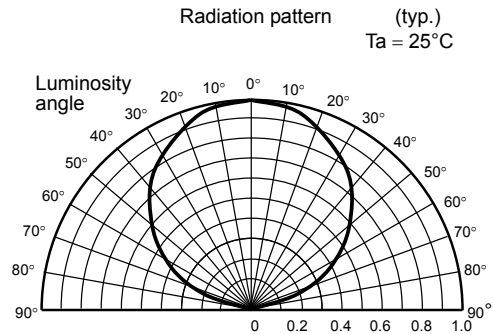
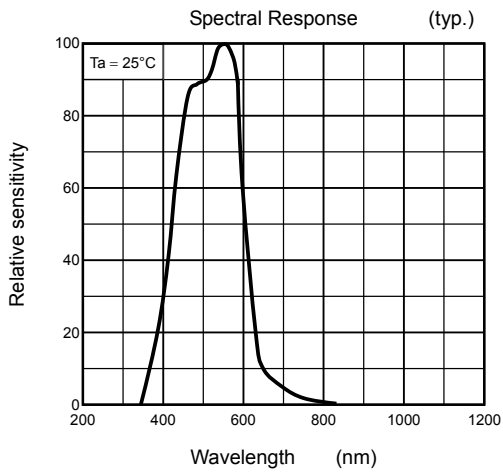
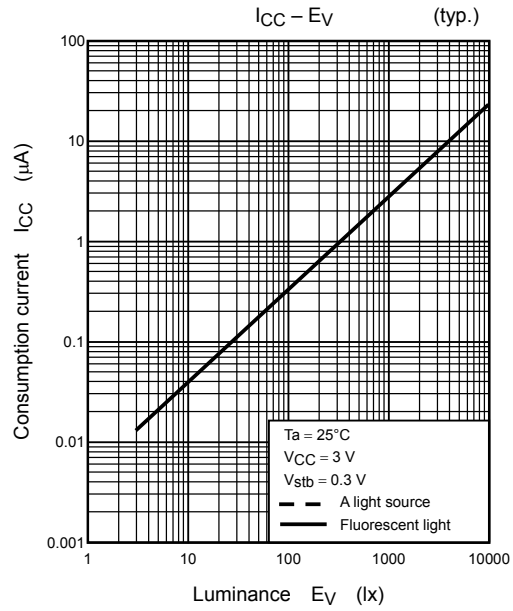
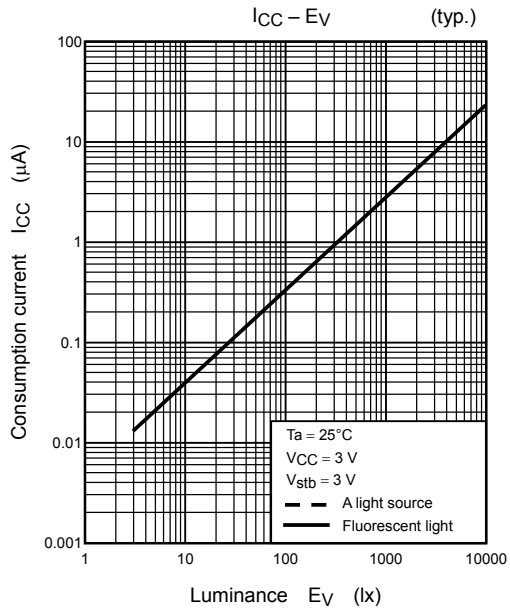

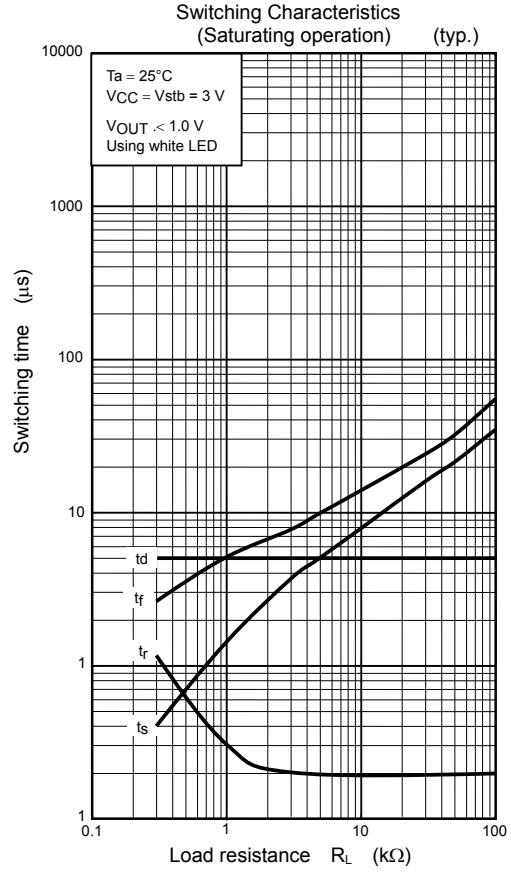
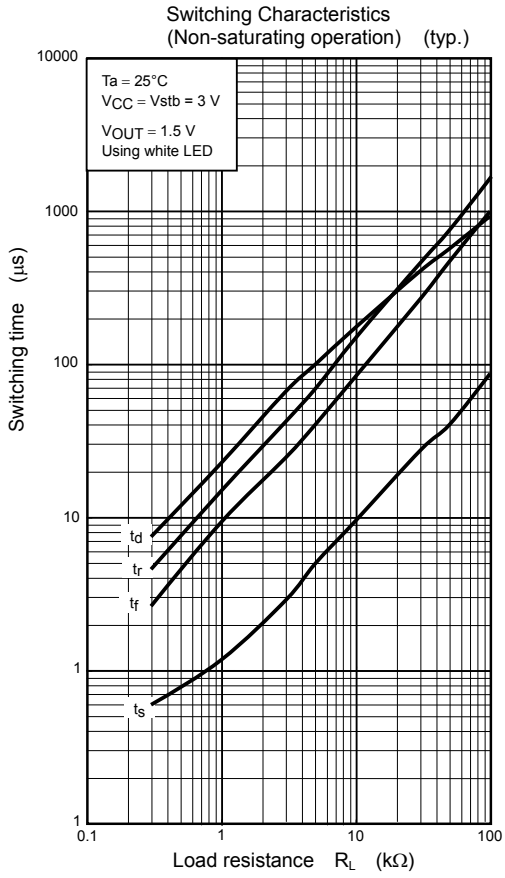

RESTRICTIONS ON PRODUCT USE

20070701-EN GENERAL

- The information contained herein is subject to change without notice.
- TOSHIBA is continually working to improve the quality and reliability of its products. Nevertheless, semiconductor devices in general can malfunction or fail due to their inherent electrical sensitivity and vulnerability to physical stress. It is the responsibility of the buyer, when utilizing TOSHIBA products, to comply with the standards of safety in making a safe design for the entire system, and to avoid situations in which a malfunction or failure of such TOSHIBA products could cause loss of human life, bodily injury or damage to property.
In developing your designs, please ensure that TOSHIBA products are used within specified operating ranges as set forth in the most recent TOSHIBA products specifications. Also, please keep in mind the precautions and conditions set forth in the "Handling Guide for Semiconductor Devices," or "TOSHIBA Semiconductor Reliability Handbook" etc.
- The TOSHIBA products listed in this document are intended for usage in general electronics applications (computer, personal equipment, office equipment, measuring equipment, industrial robotics, domestic appliances, etc.). These TOSHIBA products are neither intended nor warranted for usage in equipment that requires extraordinarily high quality and/or reliability or a malfunction or failure of which may cause loss of human life or bodily injury ("Unintended Usage"). Unintended Usage include atomic energy control instruments, airplane or spaceship instruments, transportation instruments, traffic signal instruments, combustion control instruments, medical instruments, all types of safety devices, etc.. Unintended Usage of TOSHIBA products listed in this document shall be made at the customer's own risk.
- The products described in this document shall not be used or embedded to any downstream products of which manufacture, use and/or sale are prohibited under any applicable laws and regulations.
- The information contained herein is presented only as a guide for the applications of our products. No responsibility is assumed by TOSHIBA for any infringements of patents or other rights of the third parties which may result from its use. No license is granted by implication or otherwise under any patents or other rights of TOSHIBA or the third parties.
- Please contact your sales representative for product-by-product details in this document regarding RoHS compatibility. Please use these products in this document in compliance with all applicable laws and regulations that regulate the inclusion or use of controlled substances. Toshiba assumes no liability for damage or losses occurring as a result of noncompliance with applicable laws and regulations.