

**COMPLETE TV SOUND CHANNEL**

The TDA3190 is a monolithic integrated circuit in a 16-lead dual in-line plastic package. It performs all the functions needed for the TV sound channel :

- IF LIMITER AMPLIFIER
- ACTIVE LOW-PASS FILTER
- FM DETECTOR
- DC VOLUME CONTROL
- AF PREAMPLIFIER
- AF OUTPUT STAGE

**DESCRIPTION**

The TDA3190 can give an output power of 4.2 W (d = 10 %) into a 16 Ω load at  $V_S = 24$  V, or 1.5 W (d = 10 %) into an 8 Ω load at  $V_S = 12$  V. This performance, together with the FM-IF section characteristics of high sensitivity, high AM rejection and low distortion, enables the device to be used in almost every type of television receivers.

The device has no irradiation problems, hence no external screening is needed.

The TDA3190 is a pin to pin replacement of TDA1190Z.

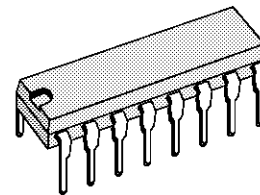

**DIP16**  
(Plastic Package)

**ORDER CODE : TDA3190**

**PIN CONNECTIONS**

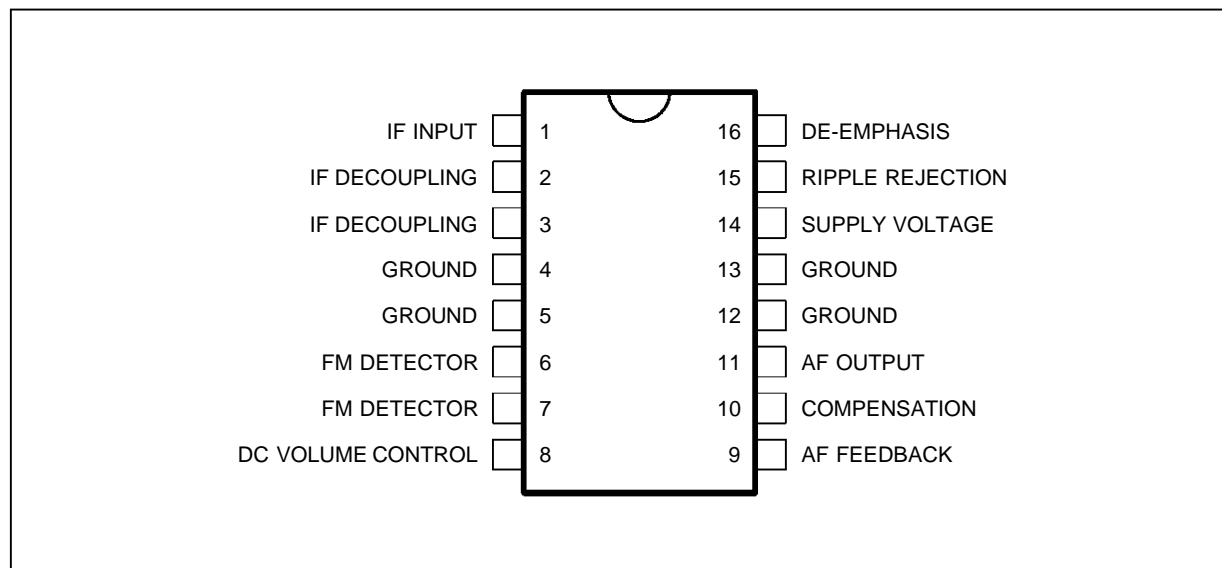

3190-01.EPS

BLOCK DIAGRAM

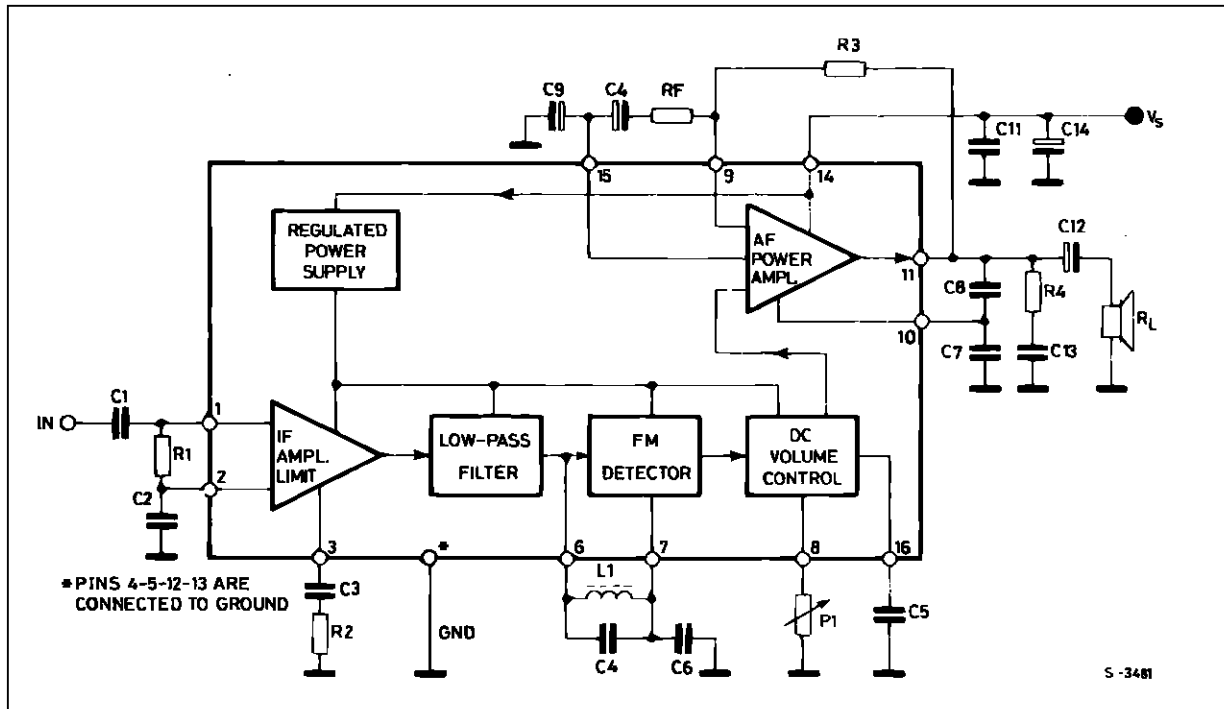

ABSOLUTE MAXIMUM RATINGS

Symbol	Parameter	Value	Unit
$V_s$	Supply Voltage (pin 10)	28	V
$V_i$	Input Signal Voltage (pin 1)	1	V
$I_o$	Output Peak Current (non-repetitive)	2	A
$I_o$	Output Peak Current (repetitive)	1.5	A
$P_{tot}$	Power Dissipation at $T_{pins} = 90^\circ C$ at $T_{amb} = 70^\circ C$ (free air)	4.3 1	W W
$T_{stg}, T_j$	Storage and Junction Temperature	- 40 to 150	$^\circ C$

THERMAL DATA

Symbol	Parameter	Value	Unit
$R_{th\ j-pins}$	Thermal Resistance Junction-pins	Max 14	$^\circ C/W$
$R_{th\ j-amb}$	Thermal Resistance Junction-ambient	Max 80*	$^\circ C/W$

\* Obtained with the GND pins soldered to printed circuit with minimized copper area.

ELECTRICAL CHARACTERISTICS

(refer to the test circuit,  $V_s = 24V$ ,  $T_{amb} = 25^\circ C$  unless otherwise specified)

Symbol	Parameter	Test Conditions	Min.	Typ.	Max.	Unit
$V_s$	Supply Voltage (Pin 14)		9		28	V
$V_o$	Quiescent Output Voltage (Pin11)	$V_s = 24V$ $V_s = 12V$	11 5.1	12 6	13 6.9	V V
$I_d$	Quiescent Drain Current	$P_1 = 22k\Omega$ $V_s = 24V$ $V_s = 12V$	11	22 19	45 40	mA mA

**ELECTRICAL CHARACTERISTICS**

(refer to the test circuit,  $V_s = 24V$ ,  $T_{amb} = 25^\circ C$  unless otherwise specified)

Symbol	Parameter	Test Conditions	Min.	Typ.	Max.	Unit
Po	Output Power	$d = 10\%$ , $f_m = 400Hz$ , $f_o = 4.5MHz$ , $\Delta f = \pm 25kHz$ $V_s = 24V$ , $R_L = 16\Omega$ $V_s = 12V$ , $R_L = 8\Omega$		4.2 1.5		W W
		$d = 2\%$ , $f_m = 400Hz$ , $f_o = 4.5MHz$ , $\Delta f = \pm 25kHz$ $V_s = 24V$ , $R_L = 16\Omega$ $V_s = 12V$ , $R_L = 8\Omega$		3.5 1.4		W W
Vi	Input Limiting Voltage (-3dB) at Pin 1	$f_o = 4.5MHz$ , $\Delta f = \pm 7.5kHz$ , $f_m = 400Hz$ , $P_1 = 0$		40	100	$\mu V$
d	Distortion	$P_o = 50mW$ , $f_m = 400Hz$ , $f_o = 4.5MHz$ , $\Delta f = \pm 7.5kHz$ $V_s = 24V$ , $R_L = 16\Omega$ $V_s = 12V$ , $R_L = 8\Omega$		0.75 1		% %
B	Frequency Response of audio amplifier (-3dB)	$R_L = 16\Omega$ , $C_8 = 120pF$ $C_7 = 470pF$ , $P_1 = 22k\Omega$ $R_f = 82\Omega$ $R_f = 47\Omega$		70 to 1200 70 to 7000		Hz Hz
Vo	Recovered Audio Voltage (Pin16)	$V_i \geq 1mV$ , $f_o = 4.5MHz$ $f_m = 400Hz$ , $\Delta f = \pm 7.5kHz$ , $P_1 = 0$		120		mV
AMR	Amplitude Modulation Rejection	$V_i \geq 1mV$ , $f_o = 4.5MHz$ , $f_m = 400Hz$ , $\Delta f = \pm 25kHz$ , $m = 0.3$		55		dB
$\frac{S+N}{N}$	Signal to Noise Ratio	$V_i \geq 1mV$ , $V_o = 4V$ , $f_o = 4.5MHz$ , $f_m = 400Hz$ , $\Delta f = \pm 25kHz$	50	65		dB
R3	External Feedback Resistance (between Pins 9 and 11)				25	k $\Omega$
Ri	Input Resistance (Pin1)	$V_i = 1mV$ , $f_o = 4.5MHz$		30		k $\Omega$
Ci	Input Capacitance (Pin1)			5		pF
SVR	Supply Voltage Rejection	$R_L = 16\Omega$ , $f_{ripple} = 120Hz$ , $P_1 = 22k\Omega$		46		dB
Av	DC Volume Control Attenuation	$P_1 = 12k\Omega$		90		dB

3190-04.TBL

**TYPICAL CIRCUIT**

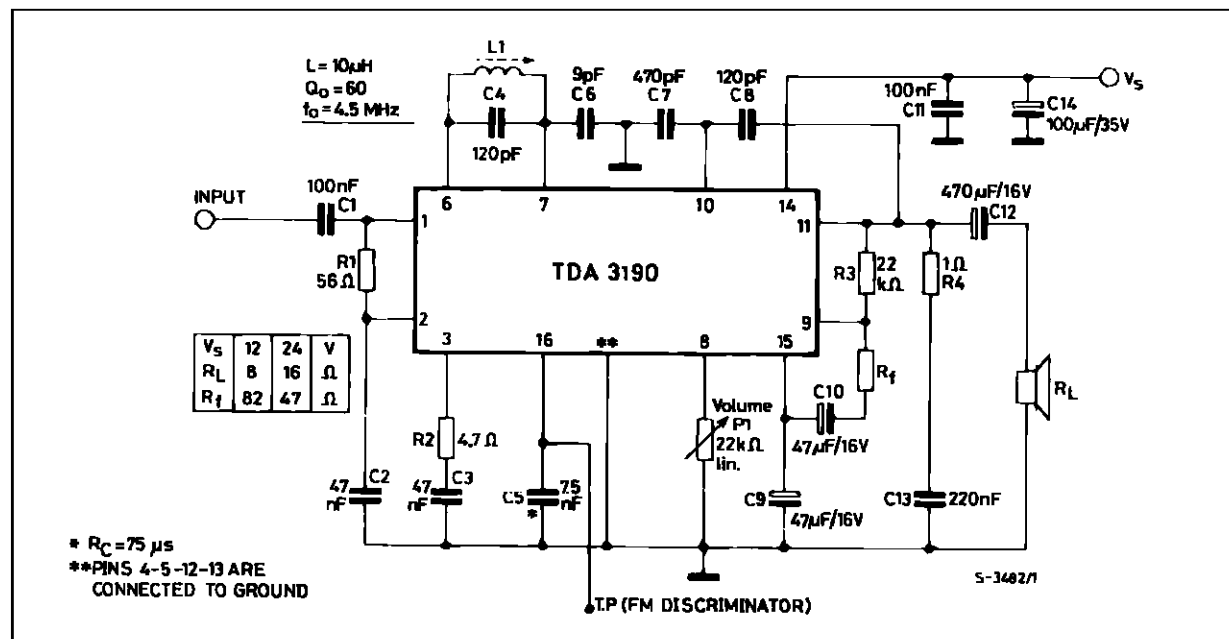

3190-03.EPS

Figure 1 : Relative Audio Output Voltage and Output Noise versus Input Signal

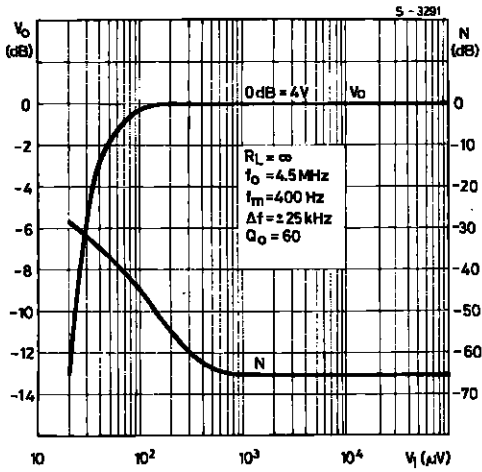

3190-04.EPS

Figure 2 : Output Voltage Attenuation versus DC Volume Control Resistance

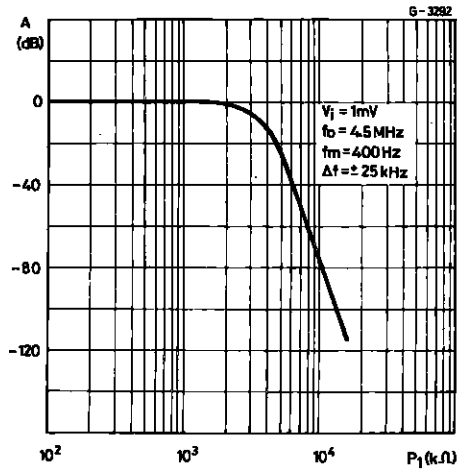

3190-05.EPS

Figure 3 : Amplitude Modulation Rejection versus Input Signal

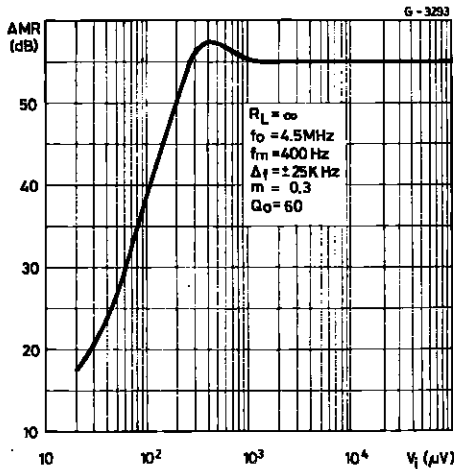

3190-06.EPS

Figure 4 :  $\Delta AMR$  versus Tuning Frequency Change

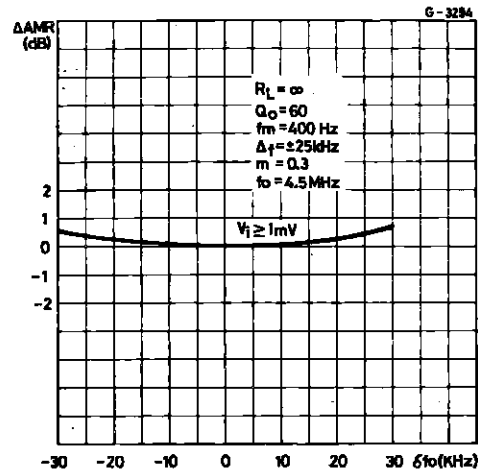

3190-07.EPS

Figure 5 : Recovered Audio Voltage versus Unloaded Q Factor of the Detector Coil

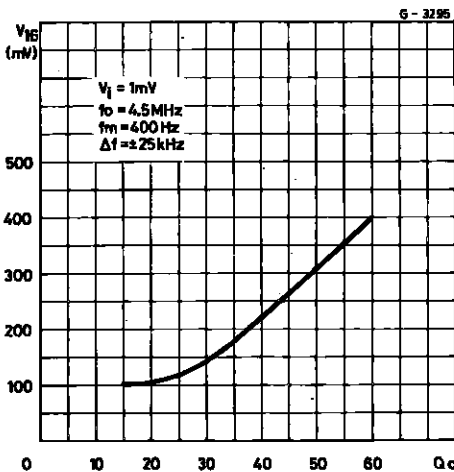

3190-08.EPS

Figure 6 : Distortion versus Output Power

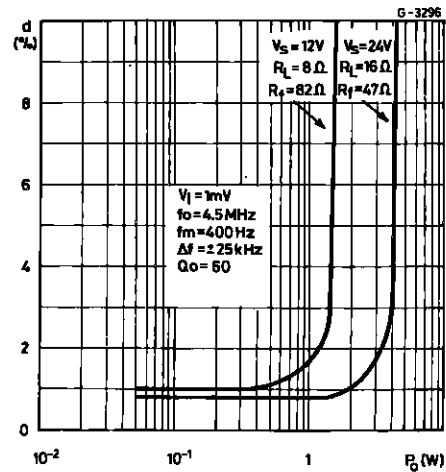

3190-09.EPS

**Figure 7 :** Distortion versus Frequency Deviation

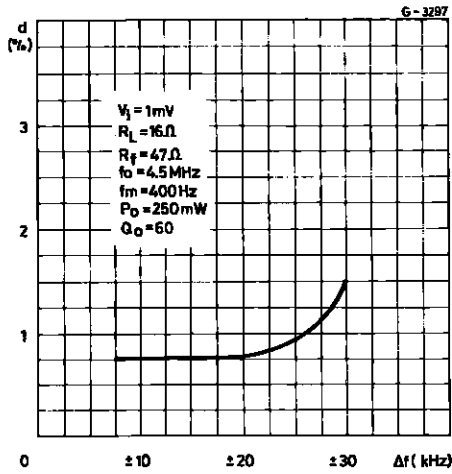

3190-10.EPS

**Figure 8 :** Distortion versus Tuning Frequency Change

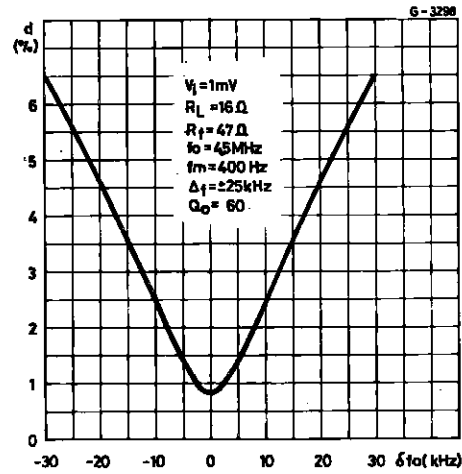

3190-11.EPS

**Figure 9 :** Audio Amplifier Frequency Response

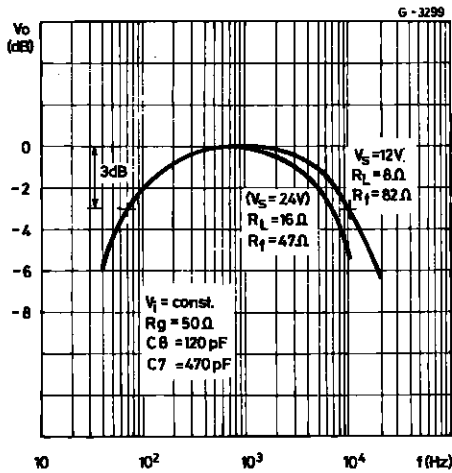

3190-12.EPS

**Figure 10 :** Supply Voltage Ripple Rejection versus Ripple Frequency

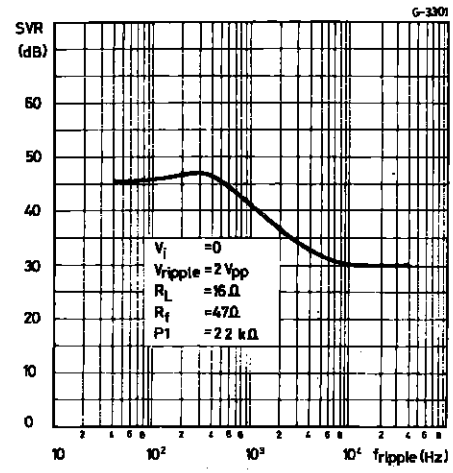

3190-13.EPS

**Figure 11 :** Supply Voltage Ripple Rejection versus Volume Control Attenuation

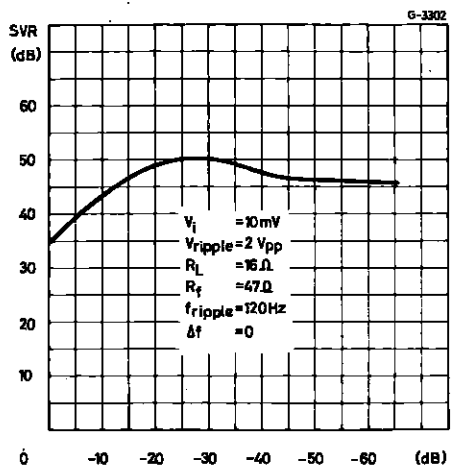

3190-14.EPS

**Figure 12 :** Output Power versus Supply Voltage

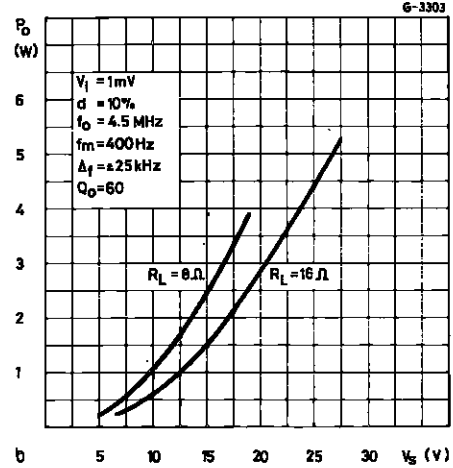

3190-15.EPS

Figure 13 : Maximum Power Dissipation versus Supply Voltage (sinewave operation)

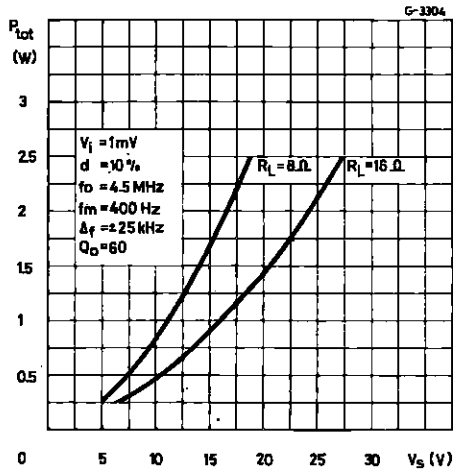

3190-16.EPS

Figure 14 : Power Dissipation and Efficiency versus Output Power

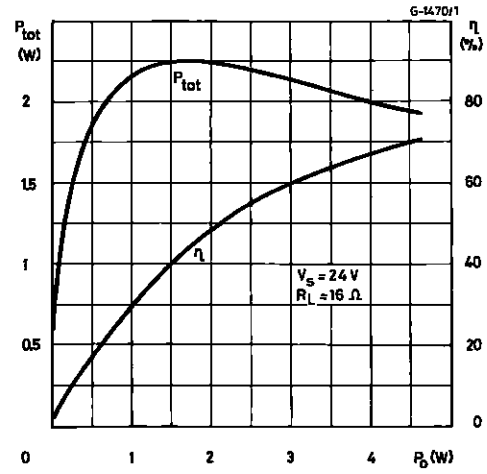

3190-17.EPS

Figure 15 : Quiescent Output Voltage (Pin 11) versus Supply Voltage

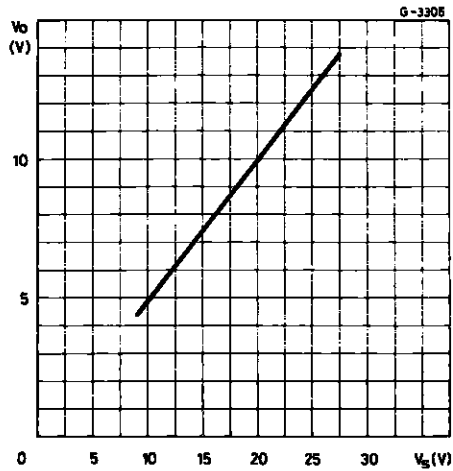

3190-18.EPS

**APPLICATION INFORMATION**

The electrical characteristics of the TDA3190 remain almost constant over the frequency range 4.5 to 6 MHz, therefore it can be used in all television standards (FM mod.). The TDA3190 has a high input impedance, so it can work with a ceramic filter or with a tuned circuit that provide the necessary input selectivity.

The value of the resistors connected to pin 9, determine the AC gain of the audio frequency amplifier. This enables the desired gain to be selected in relation to the frequency deviation at which the output stage of the AF amplifier, must enter into

clipping.

Capacitor C8, connected between pins 10 and 11, determines the upper cutoff frequency of the audio bandwidth. To increase the bandwidth the values of C8 and C7 must be reduced, keeping the ratio C7/C8 as shown in the table of fig. 16.

The capacitor connected between pin 16 and ground, together with the internal resistor of 10 KΩ forms the de-emphasis network. The Boucherot cell eliminates the high frequency oscillations caused by the inductive load and the wires connecting the loudspeaker.

**Figure 16 :** Typical Application Circuit

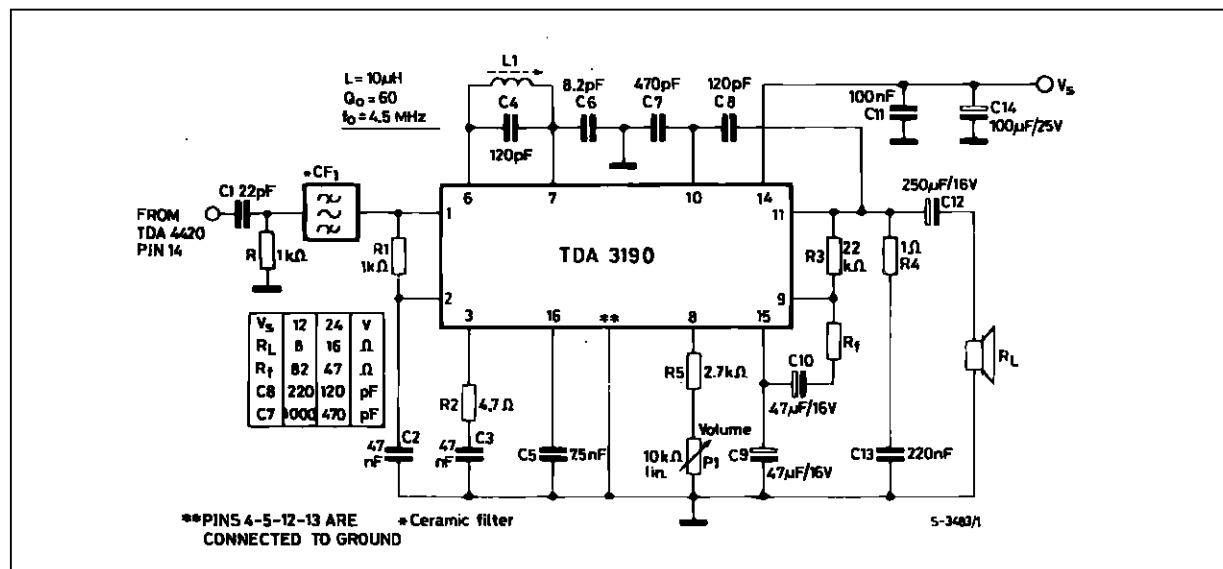

3190-19.EPS

**Figure 17 :** P.C. Board and Component Layout of the Circuit shown in Figure 16 (1 : 1 scale)

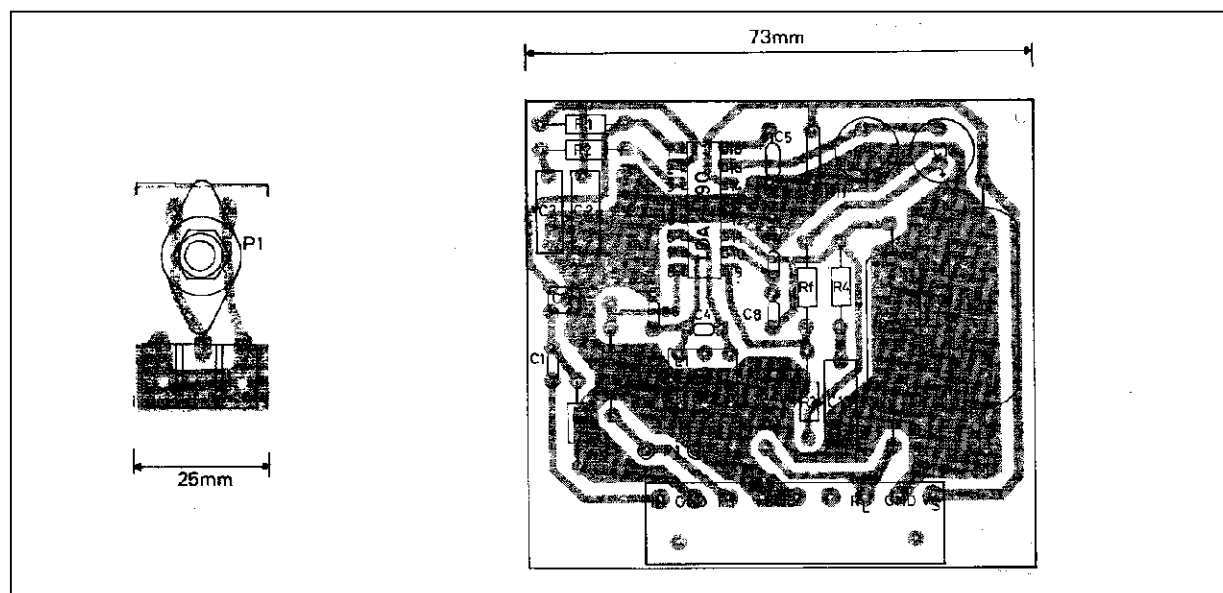

3190-20.TIF

**MOUNTING INSTRUCTION**

The  $R_{th\ j-amb}$  of the TDA3190 can be reduced by soldering the GND pins to a suitable copper area of the printed circuit board (fig. 18) or to an external heatsink (fig. 19).

The diagram of figure 20 shows the maximum dissipable power  $P_{tot}$  and the  $R_{th\ j-amb}$  as a function of the side "l" of two equal square copper areas

**Figure 18 :** Example of P.C. Board Copper Area which is used as Heatsink

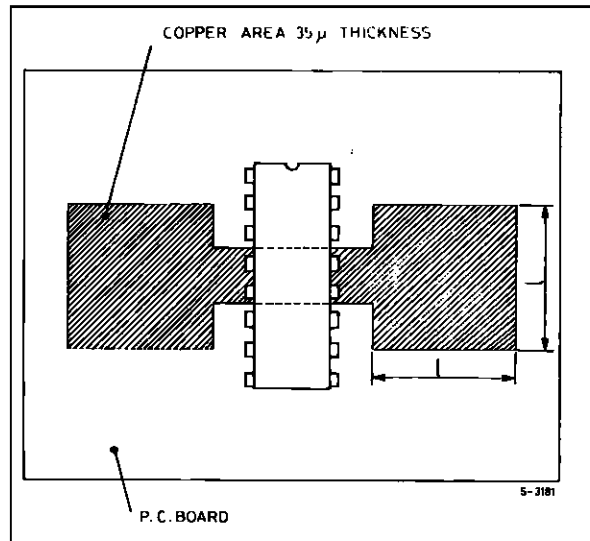

3190-21.EPS

having a thickness of  $35\ \mu$  (1.4 mils).

During soldering the pins temperature must not exceed  $260\ ^\circ\text{C}$  and the soldering time must not be longer than 12 seconds.

The external heatsink or printed circuit copper area must be connected to electrical ground.

**Figure 19 :** External Heatsink Mounting Example

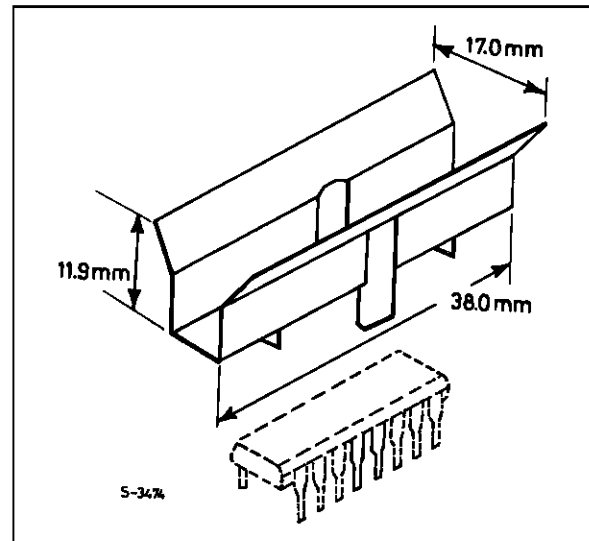

3190-22.EPS

**Figure 20 :** Maximum Dissipable Power and Junction to Ambient Thermal Resistance versus Side "T"

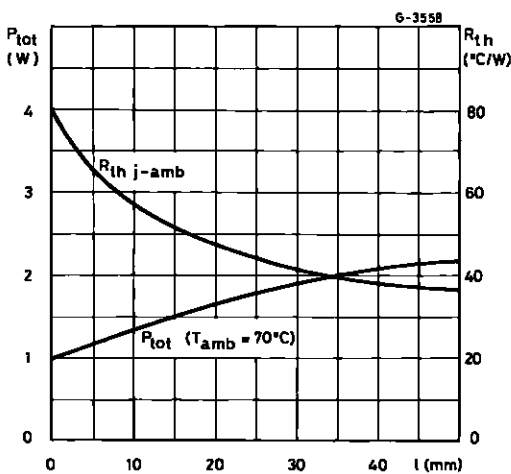

3190-23.EPS

**Figure 21 :** Maximum Allowable Power Dissipation versus Ambient Temperature

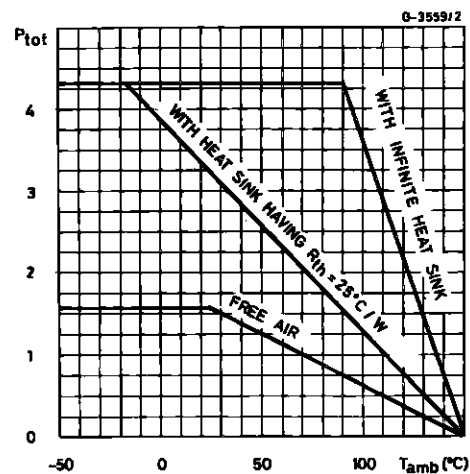

3190-24.EPS



**PACKAGE MECHANICAL DATA**  
16 PINS - PLASTIC DIP

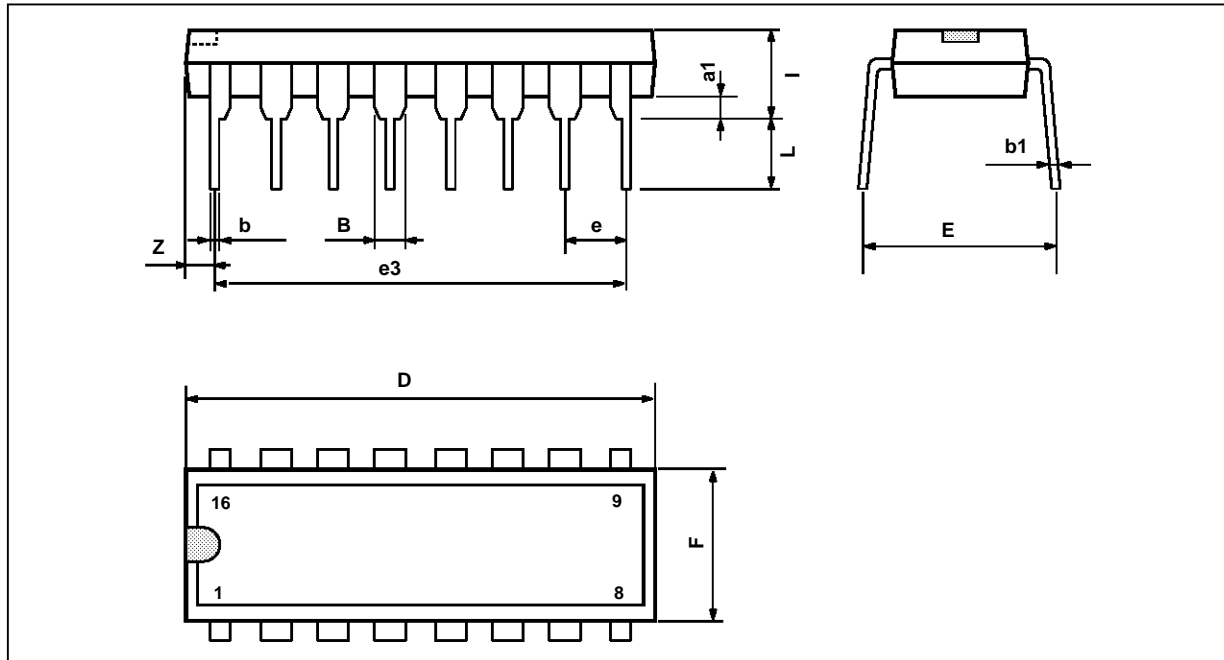

PM-DIP16.EPS

Dimensions	Millimeters			Inches		
	Min.	Typ.	Max.	Min.	Typ.	Max.
a1	0.51			0.020		
B	0.77		1.65	0.030		0.065
b		0.5			0.020	
b1		0.25			0.010	
D			20			0.787
E		8.5			0.335	
e		2.54			0.100	
e3		17.78			0.700	
F			7.1			0.280
i			5.1			0.201
L		3.3			0.130	
Z			1.27			0.050

DIP16.TBL

Information furnished is believed to be accurate and reliable. However, SGS-THOMSON Microelectronics assumes no responsibility for the consequences of use of such information nor for any infringement of patents or other rights of third parties which may result from its use. No licence is granted by implication or otherwise under any patent or patent rights of SGS-THOMSON Microelectronics. Specifications mentioned in this publication are subject to change without notice. This publication supersedes and replaces all information previously supplied. SGS-THOMSON Microelectronics products are not authorized for use as critical components in life support devices or systems without express written approval of SGS-THOMSON Microelectronics.

© 1994 SGS-THOMSON Microelectronics - All Rights Reserved

Purchase of I<sup>2</sup>C Components of SGS-THOMSON Microelectronics, conveys a license under the Philips I<sup>2</sup>C Patent. Rights to use these components in a I<sup>2</sup>C system, is granted provided that the system conforms to the I<sup>2</sup>C Standard Specifications as defined by Philips.

**SGS-THOMSON Microelectronics GROUP OF COMPANIES**

Australia - Brazil - China - France - Germany - Hong Kong - Italy - Japan - Korea - Malaysia - Malta - Morocco  
The Netherlands - Singapore - Spain - Sweden - Switzerland - Taiwan - Thailand - United Kingdom - U.S.A.