

SECAM IDENTIFICATION CIRCUIT

GENERAL DESCRIPTION

The TDA3724 is a monolithic integrated circuit for SECAM identification in PAL/SECAM (B,G) video tape recorders.

QUICK REFERENCE DATA

Supply voltage (pin 10)	$V_p = V_{10-8}$	typ.	10 V
Supply current (pin 10)	$I_p = I_{10}$	typ.	16 mA
Identification inputs	V_{3-8} (p-p)	min.	0,22 V
Identification inputs	V_{4-8} (p-p)	min.	0,22 V
Identification output current	I_1	min.	3 mA

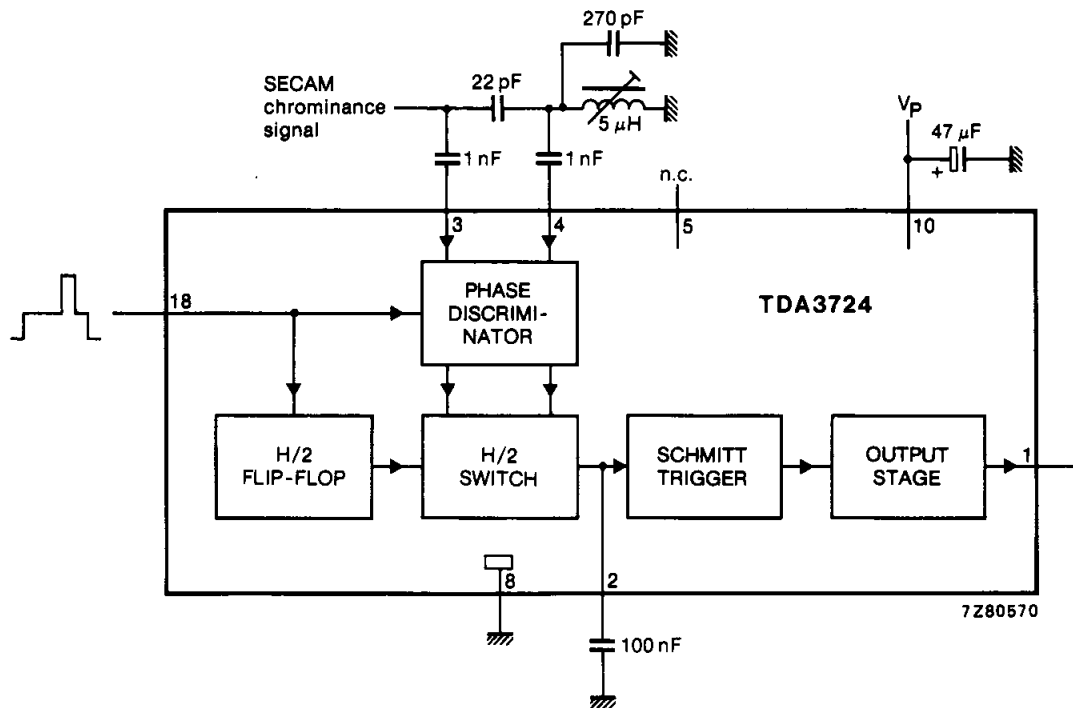

Fig. 1 Block diagram.

PACKAGE OUTLINE

18-lead DIL; plastic (SOT102).

RATINGS

Limiting values in accordance with the Absolute Maximum System (IEC 134)

Supply voltage	$V_P = V_{10-8}$	max.	13,2 V
Voltage range at pins 3,4,18	V_{n-8}		0 to V_P V
Voltage range at pin 2	V_{2-8}		$\frac{1}{2}V_P$ to V_P V
Current at pin 1	$-I_1$		5 mA
Storage temperature range	T_{stg}		-25 to +150 °C
Operating ambient temperature range	T_{amb}		0 to 70 °C

CHARACTERISTICS $V_P = 10$ V; $T_{amb} = 25$ °C; measured in Fig. 1; unless otherwise specified.

parameter	symbol	min.	typ.	max.	unit
Supply at pin 10					
Supply voltage	$V_P = V_{10-8}$	9,6	10	13,2	V
Supply current at $V_P = 10$ V	I_{10}	—	16	21	mA
Supply current at $V_P = 13,2$ V	I_{10}	—	—	28	mA
Output voltage at pin 1 (open collector of pnp transistor) at SECAM mode	V_{1-8}	9,3	—	—	V
Output current pin 1 at SECAM mode	$-I_1$	3	—	—	mA
Output current pin 1 at NOT SECAM mode	$-I_1$	—	—	10	μ A
Charge capacitor for ident. integration	C_{2-8}	100	—	2000	nF
Identification inputs pin 3,4					
input voltage	$V_{3, 4-8}$ (p-p)	0,22	—	1,0	V
input resistance	$R_{3, 4-8}$	14	—	22	k Ω
Sandcastle input pin 18					
input voltage for active discriminating stage	V_{18-8}	6,0	—	V_P	V