

## NTSC DECODER

## GENERAL DESCRIPTION

The TDA3563 is a monolithic integrated colour decoder for the NTSC standard. It combines all functions required for the identification and demodulation of NTSC signals. Furthermore it contains a luminance amplifier, an RGB-matrix and amplifier. These amplifiers supply signals up to 5,3 V peak-to-peak (picture information) enabling direct drive of the output stages. The circuit also contains inputs for data insertion, analogue as well as digital, which can be used for Teletext information, channel number display, etc.

## QUICK REFERENCE DATA

Supply voltage (pin 1)	$V_P = V_{1-27}$	typ.	12 V
Supply current (pin 1)	$I_P = I_1$	typ.	85 mA
Luminance input signal (peak-to-peak value)	$V_{10-27(p-p)}$	typ.	0,45 V
Chrominance input signal (peak-to-peak value)	$V_{3-27(p-p)}$		55 to 1100 mV
Data input signals (peak-to-peak value)	$V_{13;15;17-27(p-p)}$	typ.	1 V
RGB output signals at nominal contrast and saturation (peak-to-peak value)	$V_{12;14;16-27(p-p)}$	typ.	5,3 V
Contrast control range		typ.	20 dB
Saturation control range		min.	50 dB
Input voltage for fast video-data signal switching	$V_{9-27}$	min.	0,9 V
Blanking input voltage	$V_{8-27}$	typ.	1,5 V
Burst gating and black-level gating input voltage	$V_{8-27}$	typ.	7 V

## PACKAGE OUTLINE

28-lead DIL; plastic, with internal heat spreader (SOT-117).

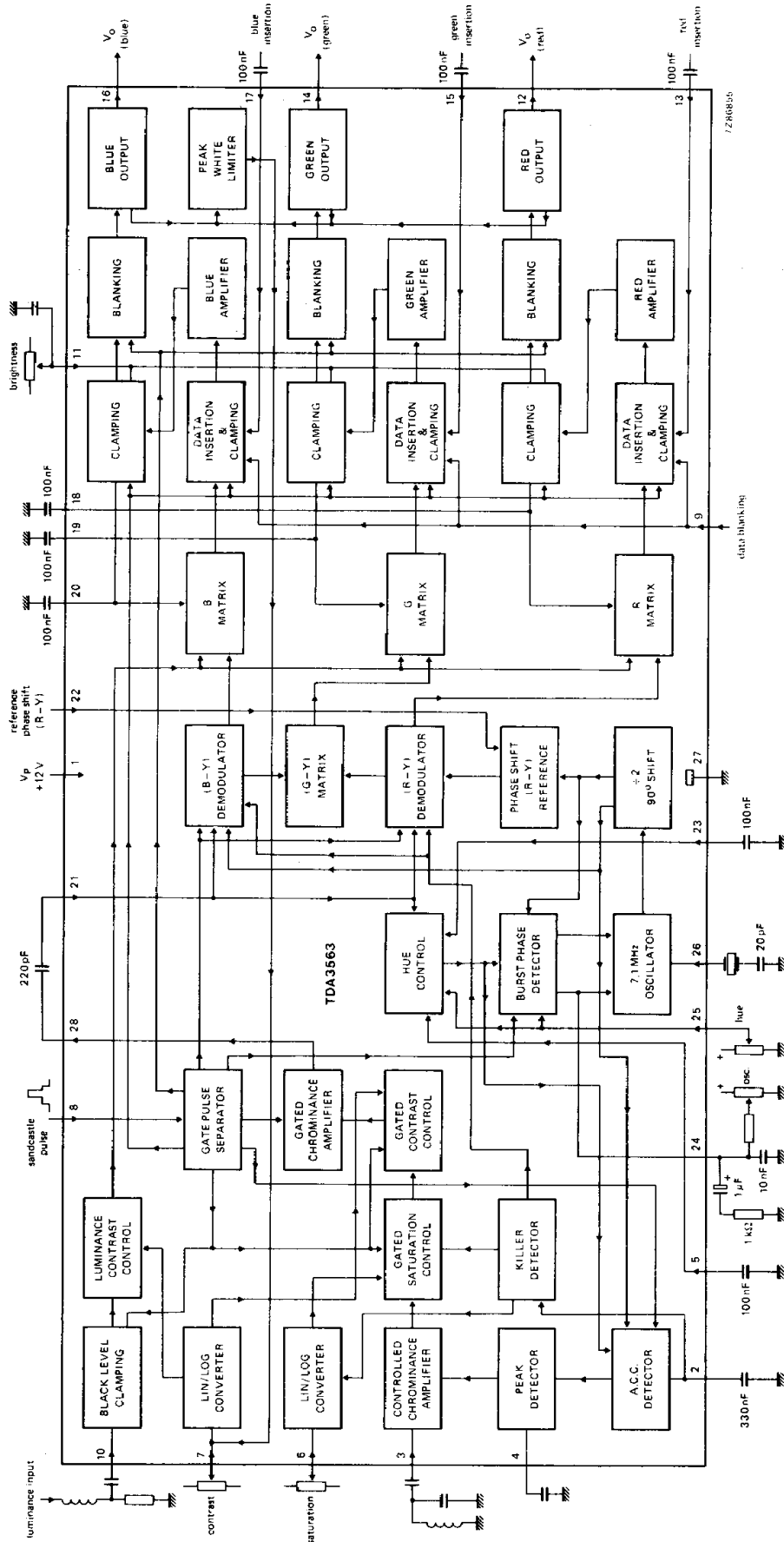

Fig. 1 Block diagram.

**RATINGS**

Limiting values in accordance with the Absolute Maximum System (IEC 134)

Supply voltage (pin 1)	$V_p = V_{1-27}$	max.	13,2 V
Total power dissipation	$P_{tot}$	max.	1,7 W
Storage temperature range	$T_{stg}$		-25 to +150 °C
Operating ambient temperature range	$T_{amb}$		-25 to +65 °C

**THERMAL RESISTANCE**

From junction to ambient (in free air)	$R_{th\ j-a}$	=	50 K/W
--	---------------	---	--------

DEVELOPMENT DATA

## CHARACTERISTICS

 $V_p = V_{1-27} = 12 \text{ V}$ ;  $T_{\text{amb}} = 25 \text{ }^\circ\text{C}$ ; unless otherwise specified

parameter	symbol	min.	typ.	max.	unit
<b>Supply (pin 1)</b>					
Supply voltage	$V_p = V_{1-27}$	10	12	13,2	V
Supply current	$I_p = I_1$	--	85	115	mA
Total power dissipation	$P_{\text{tot}}$	--	1	1,4	W
<b>Luminance amplifier</b>					
Input voltage (note 1) (peak-to-peak value)	$V_{10-27(p-p)}$	--	0,45	--	V
Contrast control range (see Fig. 2)		-17	--	+3	dB
Control voltage for an attenuation of 40 dB		--	1,2	--	V
Contrast control input current	$I_7$	--	--	15	$\mu\text{A}$
<b>Chrominance amplifier</b>					
Input voltage (note 2) (peak-to-peak value)	$V_{3-27(p-p)}$	55	550	1100	mV
A.C.C. control range		30	--	--	dB
Change of the burst signal at the output over the whole control range		--	--	1	dB
Output voltage (note 3) (peak-to-peak value) at a burst signal of 0,3 V peak to peak	$V_{28-27}$	--	0,15	--	V
Maximum output voltage range (peak-to-peak value); $R_L = 2 \text{ k}\Omega$	$V_{28-27}$	--	4	--	V
Frequency response between 0 and 5 MHz	$\alpha_{28-3}$	--	--	-2	dB
Saturation control range (see Fig. 3)		50	--	--	dB
Saturation control input current	$I_6$	--	--	20	$\mu\text{A}$
Output impedance of chrominance amplifier	$ Z_{28-27} $	--	25	--	$\Omega$
Output current	$I_{28}$	--	--	10	mA
<b>Reference part</b>					
<i>Phase-locked loop</i>					
Catching range (note 4)	$\Delta f$	500	700	--	Hz
Phase shift (notes 4 and 5)	$\Delta \varphi$	--	--	5	deg
<i>Oscillator</i>					
Temperature coefficient of oscillator frequency (note 4)	$TC_{\text{osc}}$	--	-1,5	--	Hz/K
Frequency variation when supply voltage increases from 10 V to 13,2 V (note 4)	$\Delta f_{\text{osc}}$	--	40	--	Hz

DEVELOPMENT DATA

parameter	symbol	min.	typ.	max.	unit
<b>Reference part (continued)</b>					
<i>Oscillator (continued)</i>					
Input resistance (pin 26)	R <sub>26-27</sub>	—	400	—	Ω
Input capacitance (pin 26)	C <sub>26-27</sub>	—	—	10	pF
<i>A.C.C. generation (pin 2)</i>					
Control voltage at nominal input signal	V <sub>2-27</sub>	—	5,0	—	V
Control voltage without chrominance input	V <sub>2-27</sub>	—	2,7	—	V
Colour-off voltage	V <sub>2-27</sub>	—	3,0	—	V
Colour-on voltage	V <sub>2-27</sub>	—	3,3	—	V
<i>Hue control</i>					
Control range		± 50	—	—	deg
<b>Demodulator part</b>					
Input burst signal amplitude (peak-to-peak value)	V <sub>21-27(p-p)</sub>	—	300	—	mV
Ratio for demodulated signals for equal input signal amplitudes (B-Y)/(R-Y)	$\frac{V_{16-27}}{V_{12-27}}$	—	1,06 ± 10%	—	
(G-Y)/(R-Y); no (B-Y) signal	$\frac{V_{14-27}}{V_{12-27}}$	—	-0,27 ± 20%	—	
(G-Y)/(B-Y); no (R-Y) signal	$\frac{V_{14-27}}{V_{16-27}}$	—	-0,2 ± 20%	—	
Frequency response between 0 and 1 MHz		—	—	-3	dB
<b>RGB matrix and amplifiers</b>					
Output voltage (note 3) (peak-to-peak value) at nominal luminance/contrast (black-to-white)	V <sub>12;14;16-27</sub>	4,5	5,3	6,3	V
Maximum peak-white level (note 6)	V <sub>12;14;16-27</sub>	9,0	9,3	9,6	V
Maximum output current	I <sub>12;14;16</sub>	—	—	10	mA
Output black level voltage for brightness control of 2 V		—	2,7	—	V
Brightness control voltage range			see Fig. 4		
Brightness control input current	I <sub>11</sub>	—	—	50	μA
Relative spread between R, G and B output signals		—	—	10	%
Blanking level at RGB outputs		1,9	2,1	2,3	V
Tracking of output black level with supply voltage	$\frac{\Delta V_{bl}}{V_{bl}} \times \frac{V_P}{\Delta V_P}$	—	1,1	—	

## CHARACTERISTICS (continued)

parameter	symbol	min.	typ.	max.	unit
<b>RGB matrix and amplifiers (continued)</b>					
Output impedance of RGB outputs	$ Z_{12;14;16-27} $	--	50	--	$\Omega$
Frequency response of total luminance and RGB amplifier circuits for $f = 0$ to 5 MHz		--	--	-3	dB
<b>Data insertion</b>					
Input signals (peak-to-peak value) for an RGB output voltage of 5 V (peak-to-peak)	$V_{13;15;17-27(p-p)}$	0,9	1	1,1	V
<b>Data blanking (pin 9)</b>					
Input voltage for no data insertion	$V_{9-27}$	--	--	0,3	V
Input voltage for data insertion	$V_{9-27}$	0,9	--	--	V
Maximum input voltage	$V_{9-27(m)}$	--	--	2	V
Delay of data blanking	$t_d$	--	--	20	ns
Input current	$I_g$	--	--	35	$\mu A$
<b>Sandcastle input (pin 8)</b>					
Level at which RGB blanking is activated	$V_{8-27}$	1	1,5	2	V
Level at which burst gating and clamping pulse are separated	$V_{8-27}$	6,5	7,0	7,5	V
Delay between black level clamping and burst gating pulse	$t_d$	--	0,4	--	$\mu s$
Input current					
at $V_{8-27} = 0$ to 1 V	$-I_g$	--	--	1	mA
at $V_{8-27} = 1$ to 8,5 V	$I_g$	--	20	--	$\mu A$
at $V_{8-27} = 8,5$ to 12 V	$I_g$	--	--	2	mA

## Notes to the characteristics

1. Signal with negative-going sync; amplitude includes sync amplitude.
2. Indicated is a signal for a colour bar with 75% saturation; chrominance to burst ratio is 2,2 : 1.
3. At nominal contrast and saturation. Nominal contrast is specified as the maximum contrast -3 dB and nominal saturation as the maximum saturation -6 dB.
4. All frequency variations are referred to 3,58 MHz carrier frequency.
5. For  $\pm 400$  Hz deviation of the oscillator frequency.
6. If the typical voltage for this white level is exceeded, the output voltage is reduced by discharging the capacitor at pin 7 (contrast control); discharge current is 1,5 mA.

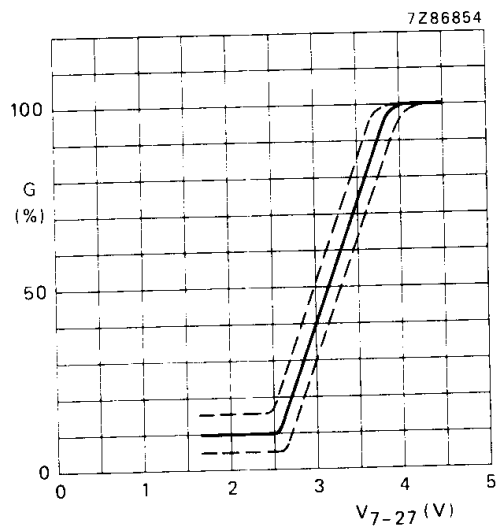

Fig. 2 Contrast control voltage range.

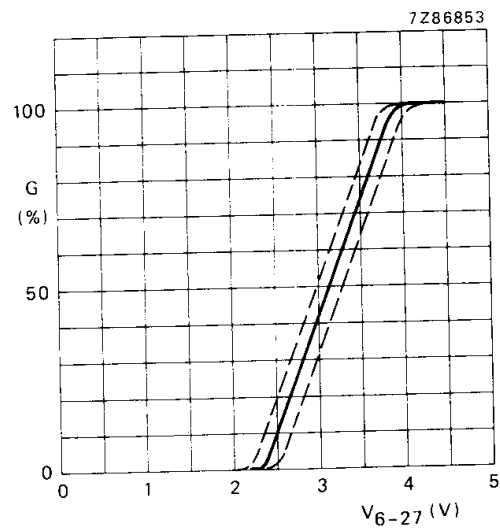

Fig. 3 Saturation control voltage range.

DEVELOPMENT DATA

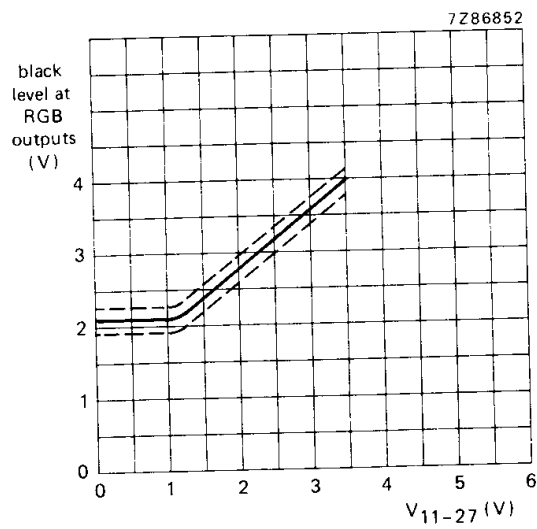

Fig. 4 Brightness control voltage range.

## APPLICATION INFORMATION

The function is described against the corresponding pin number.

### 1. + 12 V power supply

The circuit gives good operation in a supply voltage range between 8 and 13,2 V provided that the supply voltage for the controls is equal to the supply voltage of the TDA3563. All signal and control levels have a linear dependency on the supply voltage. The current consumed by the IC at + 12 V is typically 85 mA. It is linearly dependent on the supply voltage.

### 2. Control voltage for identification

The output pulses of the a.c.c. detector are detected with a sample-and-hold circuit to obtain information for the colour killer. The output is available at pin 2.

### 3. Chrominance input

The chrominance signal must be a.c.-coupled to the input. Its amplitude must be between 55 and 1100 mV peak-to-peak (25 to 500 mV peak-to-peak burst signal). All figures for the chrominance signals are based on a colour bar signal with 75% saturation, that is if the burst-to-chrominance ratio of the input is 1 : 2,2.

### 4. Control voltage a.c.c. detector

The shifted burst signal is synchronously demodulated in a separate a.c.c. detector to generate the a.c.c. voltage. The output pulses of this detector are peak detected to control the gain of the chrominance amplifier, thus preventing blooming-up of the colour during weak signal reception.

### 5. Decoupling of the 90° phase shift circuit

A control circuit is required in the 90° phase shift circuit to make the chrominance voltage independent of the hue setting. The control circuit is decoupled by a capacitor at this pin.

### 6. Saturation control

The saturation control range is in excess of 50 dB. The control voltage range is 2 to 4 V. Saturation control is a linear function of the control voltage.

When the colour killer is active, the saturation control voltage is reduced to a low level if the resistance of the external control network is sufficiently high. Then the chrominance amplifier supplies no signal to the demodulator. Colour switch-on can be delayed by proper choice of the time constant for the saturation control setting circuit.

When the saturation control pin is connected to the power supply the colour killer circuit is overruled so that the colour signal is visible on the screen. In this way it is possible to adjust the oscillator frequency without using a frequency counter (see also pins 24 and 26).

### 7. Contrast control

The contrast control range is 20 dB for a control voltage change from + 2 V to + 4 V. Contrast control is a linear function of the control voltage. The output signal is suppressed when the control voltage is 1 V or less. If one or more output signals surpasses the level of 9 V the peak-white limiter circuit becomes active and reduces the output signals via the contrast control by discharging a 10  $\mu$ F capacitor via an internal current sink.

### 8. Sandcastle and vertical blanking input

The output signals are blanked if the amplitude of the pulse is between 2 V and 6,5 V. The burst gate and clamping circuits are activated if the input pulse exceeds a level of 7,5 V. The higher part of the sandcastle pulse should start just after the sync pulse to prevent clamping of the video signal on the sync pulse. The duration should be about 4  $\mu$ s for proper a.c.c. operation.



**9. Video-data switching**

The insertion circuit is activated by means of this input by an input pulse between 1 and 2 V. In that condition, the internal RGB signals are switched off and the inserted signals are supplied to the output amplifiers. If only normal operation is wanted this pin should be connected to ground (pin 27). The switching times are very short ( $< 20$  ns) to avoid coloured edges of the inserted signals on the screen.

**10. Luminance signal input**

The input signal should have a peak-to-peak amplitude of 0,45 V (peak-white to sync) to obtain a black-white output signal of 5,3 V at nominal contrast. It must be a.c.-coupled to the input by a capacitor of about 22 nF. The signal is clamped at the input to an internal reference voltage. The 1 k $\Omega$  luminance delay line can be applied because the luminance impedance is very high. Consequently the charging and discharging currents of the coupling capacitor are very small and do not influence the signal level at the input noticeably. Additionally the coupling capacitor value may be small.

**11. Brightness control**

The black level of the RGB outputs can be set by the voltage on this pin (see Fig. 4). The minimum black level is identical to the blanking level. The black level can be set higher than 4 V, however, the available output signal amplitude is reduced (see also pin 7). Brightness control also operates on the black level of the inserted signals.

**12, 14, 16. RGB outputs**

The output circuits for red, green and blue are identical. Output signals are 5,3 V (black-white) for nominal input signals and control settings. The black levels of the three outputs have the same value. The blanking level at the outputs is 2,1 V. The peak-white level is limited to 9 V. When this level is exceeded the output signal amplitude is reduced via the contrast control (see also pin 7).

**13, 15, 17. Inputs for external RGB signals**

The external signals must be a.c.-coupled to the inputs via a coupling capacitor of about 100 nF. Source impedance should not exceed 150  $\Omega$ . The input signal required for a 5 V peak-to-peak output signal is 1 V peak to peak. At the RGB outputs the black level of the inserted signal is identical to that of normal RGB signals. When these inputs are not used the coupling capacitors have to be connected to ground (pin 27).

**18, 19, 20. Black level clamp capacitors**

The black level clamp capacitors for the three channels are connected to these pins. The value of each capacitor should be about 100 nF.

**21, 22. Demodulator input and reference signal phase adjustment**

The (R-Y) and (B-Y) demodulator inputs are internally connected (pin 21). The phase angle between the two reference carriers is 115°. At the nominal hue adjustment the (B-Y) signal is demodulated with a difference of 0°. The phase shift of 115° can be changing the voltage at pin 22. The gain at the two demodulators is identical. The (G-Y) is composed of  $-0,27(R-Y) - 0,22(B-Y)$ .

**23, 25. Hue control**

The hue control is obtained by changing the phase of the input signal of the burst phase detector with respect to the demodulator input signal. This phase shift is obtained by generating a 90° shifted sine-wave via a Miller integrator (biased via pin 23) which is mixed with the original burst signal.

## APPLICATION INFORMATION (continued)

### 24, 26. Reference oscillator

As the burst phase detector has an asymmetrical output the oscillator can be adjusted by changing the voltage of the output (pin 24) via a high-ohmic resistor. The capacitor in series with the oscillator crystal must then have a fixed value. When pin 6 (saturation control) is connected to the positive supply line the burst phase detector is based in its nominal position and the colour killer is overruled. This position can therefore be used for the adjustment of the oscillator.

### 27. Ground

### 28. Output of the chrominance amplifier

The (R-Y) and (B-Y) demodulator input (pin 21) is a.c.-coupled to this output.