

## VERTICAL DEFLECTION CIRCUIT (90°)

The TDA3651 is a vertical deflection output circuit for drive of various deflection systems with deflection currents up to 1,5 A peak-to-peak.

The circuit incorporates the following functions:

- Driver
- Output stage
- Thermal protection and output stage protection
- Flyback generator
- Voltage stabilizer

### QUICK REFERENCE DATA

Supply voltage (pin 9)	$V_{9-4} = V_p$	0 to 50 V
Peak output voltage during flyback (pin 5)	$V_{5-4M} <$	55 V
Output current (peak-to-peak value)	$I_5(p-p) <$	1,5 A
Operating junction temperature	$T_j$ max.	150 °C

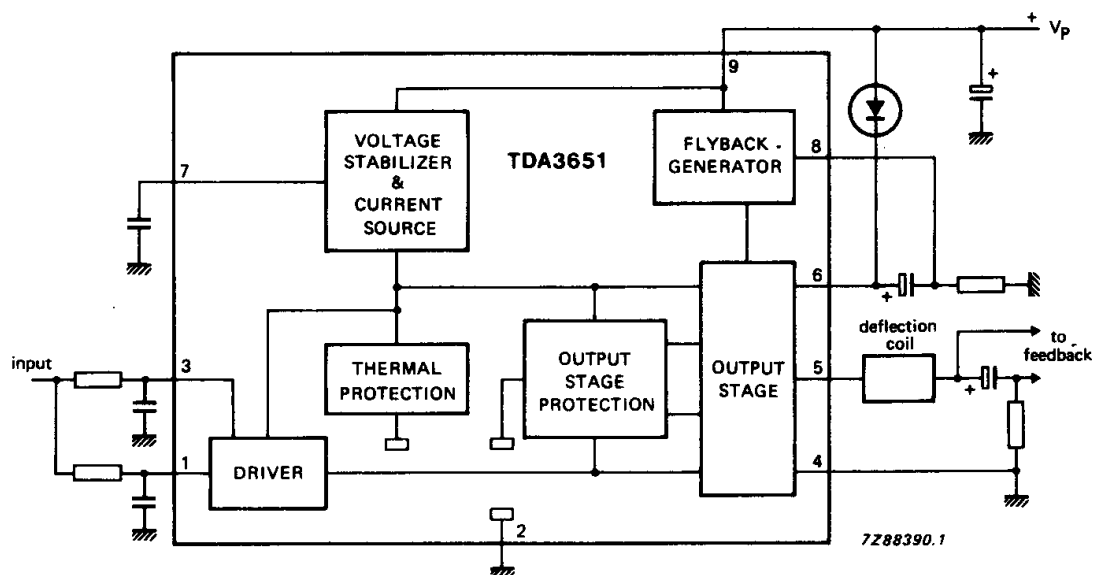

Fig. 1 Block diagram.

### PACKAGE OUTLINES

TDA3651: 9-lead SIL; plastic (SOT-110B).

TDA3651A: 9-lead SIL; plastic power (SOT-131).

TDA3651AQ: 9-lead SIL bent to DIL; plastic power (SOT-157).

## GENERAL DESCRIPTION

### Output stage and protection circuit

Pin 5 is the output pin. The supply for the output stage is fed to pin 6 and the output stage ground is connected to pin 4. The output transistors of the class-B output stage can each deliver 0,75 A maximum. The 'upper' power transistor is protected against short-circuit currents to ground, whereas, during flyback, the 'lower' power transistor is protected against too high voltages which may occur during adjustments.

Moreover, the output transistors have been given extra solidity by means of special measures in the internal circuit layout.

A thermal protection circuit is incorporated to protect the IC against too high dissipation. This circuit is 'active' at 175 °C and then reduces the deflection current to such a value that the dissipation cannot increase.

### Driver and switching circuit

Pin 1 is the input for the driver of the output stage. The signal at pin 1 is also applied via a resistor to pin 3 which is the input of a switching circuit. When the flyback starts, this switching circuit rapidly turns off the lower output stage and so limits the turn-off dissipation. It also allows a quick start of the flyback generator. Pin 3 is connected externally via resistors to pin 1 in order to allow for different applications in which pin 3 and pin 1 are driven separately.

### Flyback generator

The capacitor at pin 6 is charged to a maximum voltage, which is equal to the supply voltage  $V_p$  (pin 9), during scan.

When the flyback starts and the voltage at the output pin (pin 5) exceeds the supply voltage (pin 9), the flyback generator is activated. The  $V_p$  is connected in series (via pin 8) with the voltage across the capacitor.

The voltage at the supply pin (pin 6) of the output stage will then be maximum twice  $V_p$ . Lower voltages can be chosen by changing the value of the external resistor at pin 8.

### Voltage stabilizer

The internal voltage stabilizer provides a stabilized supply of 6 V for drive of the output stage, so the drive current of the output stage is not affected by supply voltage variations. The stabilized voltage is available at pin 7.

A decoupling capacitor of 2,2  $\mu\text{F}$  can be connected to this pin.

**RATINGS**

Limiting values in accordance with the Absolute Maximum System (IEC 134)

**Voltages** (pins 4 and 2 externally connected to ground)

Output voltage (pin 5)	$V_{5-4}$	max.	55 V
Supply voltage (pin 9)	$V_{9-4} = V_P$	max.	50 V
Supply voltage output stage (pin 6)	$V_{6-4}$	max.	55 V
Input voltage (pins 1 and 3)	$V_{1-2}; V_{3-2}$	max.	$V_P$

**Currents**

Repetitive peak output current (pin 5)	$\pm I_{5RM}$	max.	0,75 A
Non-repetitive peak output current (pin 5)	$\pm I_{5SM}$	max.	1,5 A*
Repetitive peak flyback generator output current (pin 8)	$I_{8RM}$	max.	-0,75 A +0,85 A
Non-repetitive peak flyback generator output current (pin 8)	$I_{8SM}$	max.	-1,5 A +1,6 A*

**Temperatures**

Storage temperature range	$T_{stg}$	-65 to + 150 °C
Operating ambient temperature range	$T_{amb}$	-25 to + 65 °C
Operating junction temperature range	$T_j$	-25 to + 150 °C

**CHARACTERISTICS** $T_{amb} = 25\text{ °C}$ ;  $V_P = 26\text{ V}$ ; pins 4 and 2 externally connected to ground; unless otherwise specified.

Output current (peak-to-peak value)	$I_{5(p-p)}$	typ.	1,2 A
		<	1,5 A
Flyback generator output current	$-I_8$	typ.	0,7 A
		<	0,85 A
Flyback generator output current	$I_8$	typ.	0,6 A
		<	0,75 A

**Output voltages**

Peak voltage during flyback	$V_{5-4M}$	<	55 V
Saturation voltage to supply at $-I_5 = 0,75\text{ A}$	$-V_{5-6sat}$	typ.	2,5 V
		<	3,0 V
Saturation voltage to ground at $I_5 = 0,75\text{ A}$	$V_{5-4sat}$	typ.	2,5 V
		<	3,0 V
Saturation voltage to supply at $-I_5 = 0,6\text{ A}$	$-V_{5-6sat}$	typ.	2,2 V
		<	2,7 V
Saturation voltage to ground at $I_5 = 0,6\text{ A}$	$V_{5-4sat}$	typ.	2,2 V
		<	2,7 V

\* Non-repetitive duty factor maximum 3,3%.

**Supply**

Supply voltage	V <sub>9-2; 4</sub>	10 to 50 V*
Supply voltage output stage	V <sub>6-4</sub>	< 55 V*
Supply current (no load and no quiescent current)	I <sub>g</sub>	typ. 9 mA
		< 12 mA
Quiescent current (see Fig. 2)	I <sub>4</sub>	typ. 38 mA
		25 to 52 mA
Variation of quiescent current with temperature	TC	typ. -0,04 mA/K

**Flyback generator**

Saturation voltage at -I <sub>g</sub> = 0,85 A	V <sub>9-8sat</sub>	typ. 1,6 V
		< 2,1 V
Saturation voltage at I <sub>g</sub> = 0,75 A	V <sub>8-9sat</sub>	typ. 2,5 V
		< 3,0 V
Saturation voltage at I <sub>g</sub> = 0,7 A	V <sub>9-8sat</sub>	typ. 1,4 V
		< 1,9 V
Saturation voltage at I <sub>g</sub> = 0,6 A	V <sub>8-9sat</sub>	typ. 2,3 V
		< 2,8 V
Flyback generator active if:	V <sub>5-9</sub>	> 4 V
Leakage current	-I <sub>g</sub>	typ. 5 μA
		< 100 μA
Input current for ± I <sub>5</sub> = 0,75 A	I <sub>1</sub>	typ. 230 μA
		175 to 380 μA
Input voltage during scan	V <sub>1-2</sub>	typ. 1,9 V
		0,9 to 2,7 V
Input current during scan	I <sub>3</sub>	0,01 to 2,5 mA
Input voltage during scan	V <sub>3-2</sub>	0,9 to V <sub>p</sub> V
Input voltage during flyback	V <sub>3-2</sub>	0 to 0,2 V
Voltage at pin 7	V <sub>7-2</sub>	typ. 6,1 V
		5,6 to 6,9 V
Load current of pin 7	I <sub>7</sub>	< 2 mA
Unloaded voltage at pin 7 during flyback	V <sub>7-2</sub>	typ. 15 V
Junction temperature of switching on the thermal protection	T <sub>j</sub>	typ. 175 °C
		158 to 192 °C
Thermal resistance from crystal to mounting base	R <sub>th c-mb</sub>	typ. 3 K/W
		< 4 K/W
TDA3651A; AQ	R <sub>th c-tab</sub>	typ. 10 K/W
		< 12 K/W
Power dissipation	see Fig. 3a or 3b	
Open loop gain at 1 kHz; R <sub>load</sub> = 1 kΩ	G <sub>o</sub>	typ. 36 dB
Frequency response (-3 dB); R <sub>load</sub> = 1 kΩ	f	typ. 60 kHz

\* Take care that during flyback the voltage at pin 5 does not exceed 55 V.

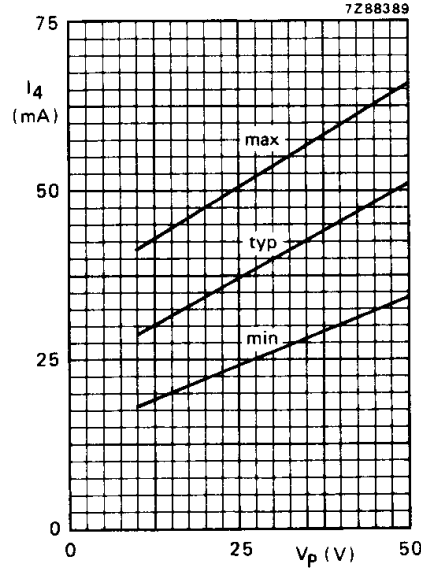

Fig. 2 Quiescent current  $I_4$  as a function of supply voltage  $V_p$ .

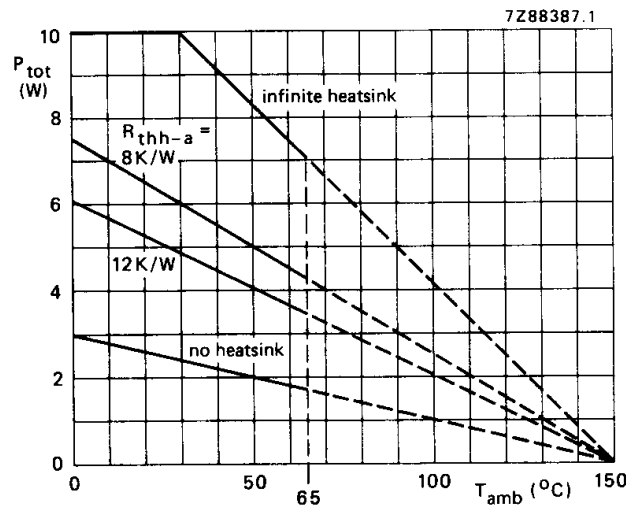

Fig. 3a Power derating curves TDA3651.

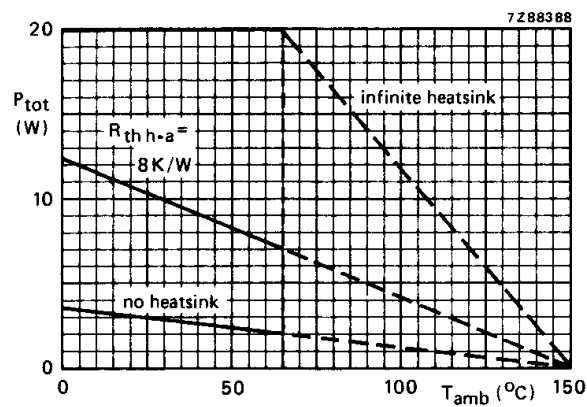

Fig. 3b Power derating curves TDA3651A; AQ.

**APPLICATION INFORMATION**

The following application data are measured in a typical application as shown in Figs 4 and 5.

Deflection current (including 6% overscan)

peak-to-peak value

$I_5(p-p)$  typ. 0,87 A

Supply voltage

$V_{g-4}$  typ. 26 V

Total supply current

$I_{tot}$  typ. 148 mA

Peak output voltage during flyback

$V_{5-4M}$  < 50 V

Saturation voltage to supply

$V_{5-6sat}$  typ. 2,0 V  
< 2,5 V

Saturation voltage to ground

$V_{5-4sat}$  typ. 2,0 V  
< 2,5 V

Flyback time

$t_{fl}$  typ. 0,95 ms  
< 1,2 ms

Total power dissipation in IC

$P_{tot}$  typ. 2,5 W

Operating ambient temperature

$T_{amb}$  < 65 °C

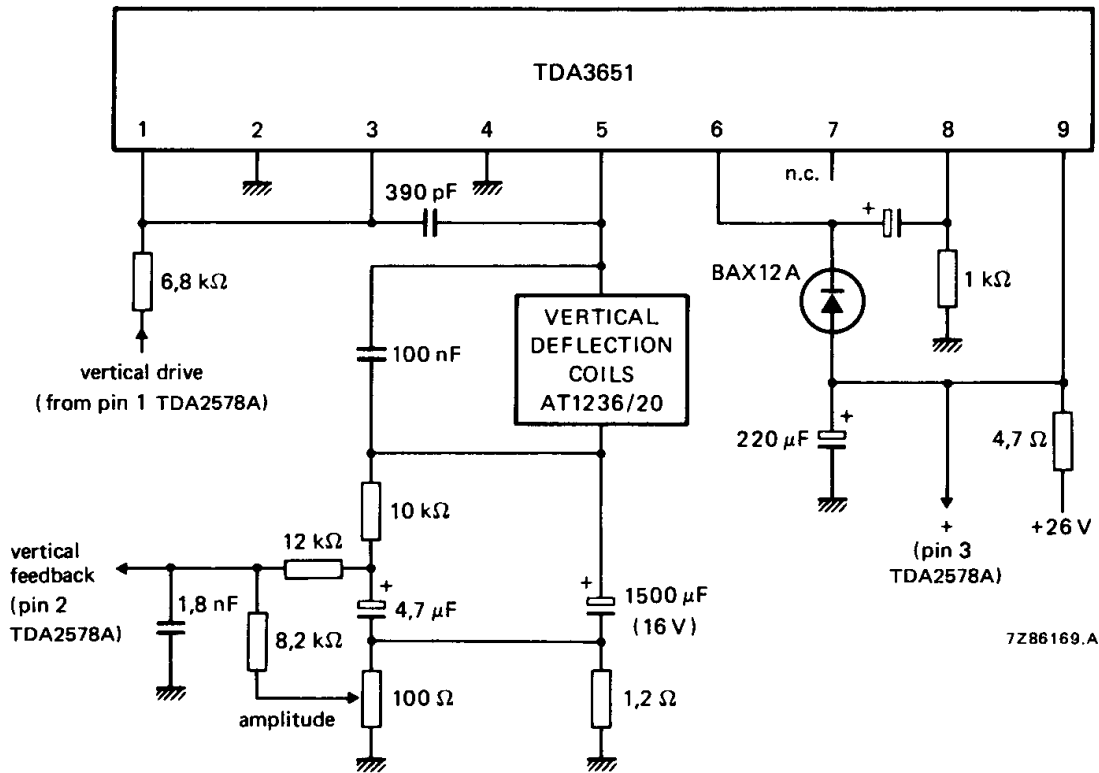

Fig. 4 Typical application circuit diagram of the TDA3651 (vertical output), when used in combination with the TDA2578A (see Fig. 5).

Note to deflection coils AT1236/20: L = 29 mH, R = 13,6 Ω; deflection current without overscan is 0,82 A peak-to-peak and EHT voltage is 25 kV.

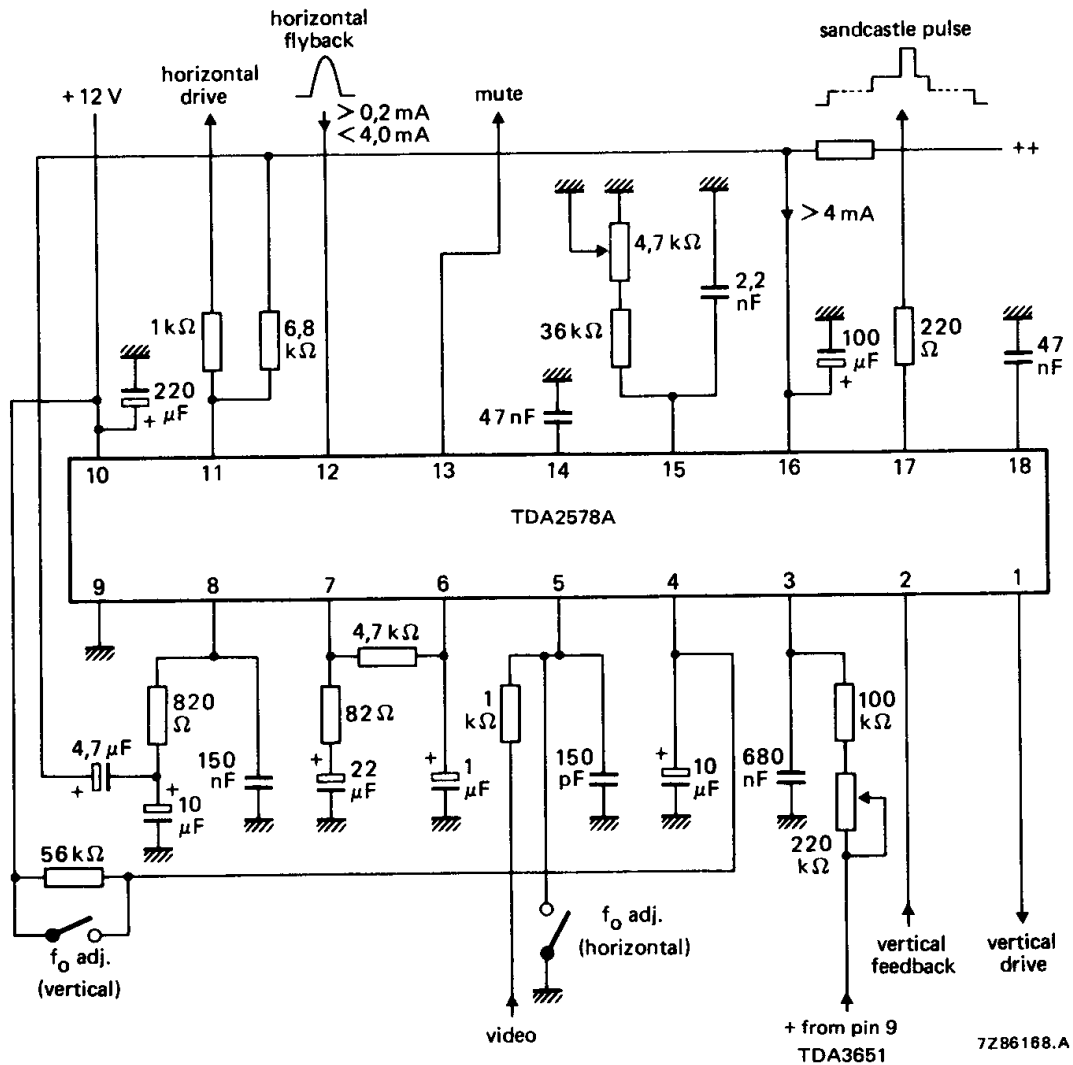

Fig. 5 Typical application circuit diagram; for combination of the TDA2578A with the TDA3651 (see Fig. 4).

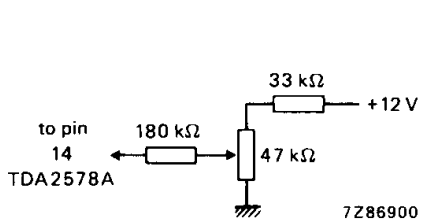

Fig. 6 Circuit configuration at pin 14 for phase adjustment.

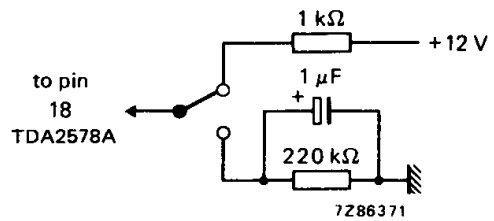

Fig. 7 Circuit configuration at pin 18 for VCR mode.  
1 kΩ resistor between pin 18 and + 12 V:  
without mute function.  
220 kΩ between pin 18 and ground:  
with mute function.

TDA3651  
TDA3651A  
TDA3651AQ

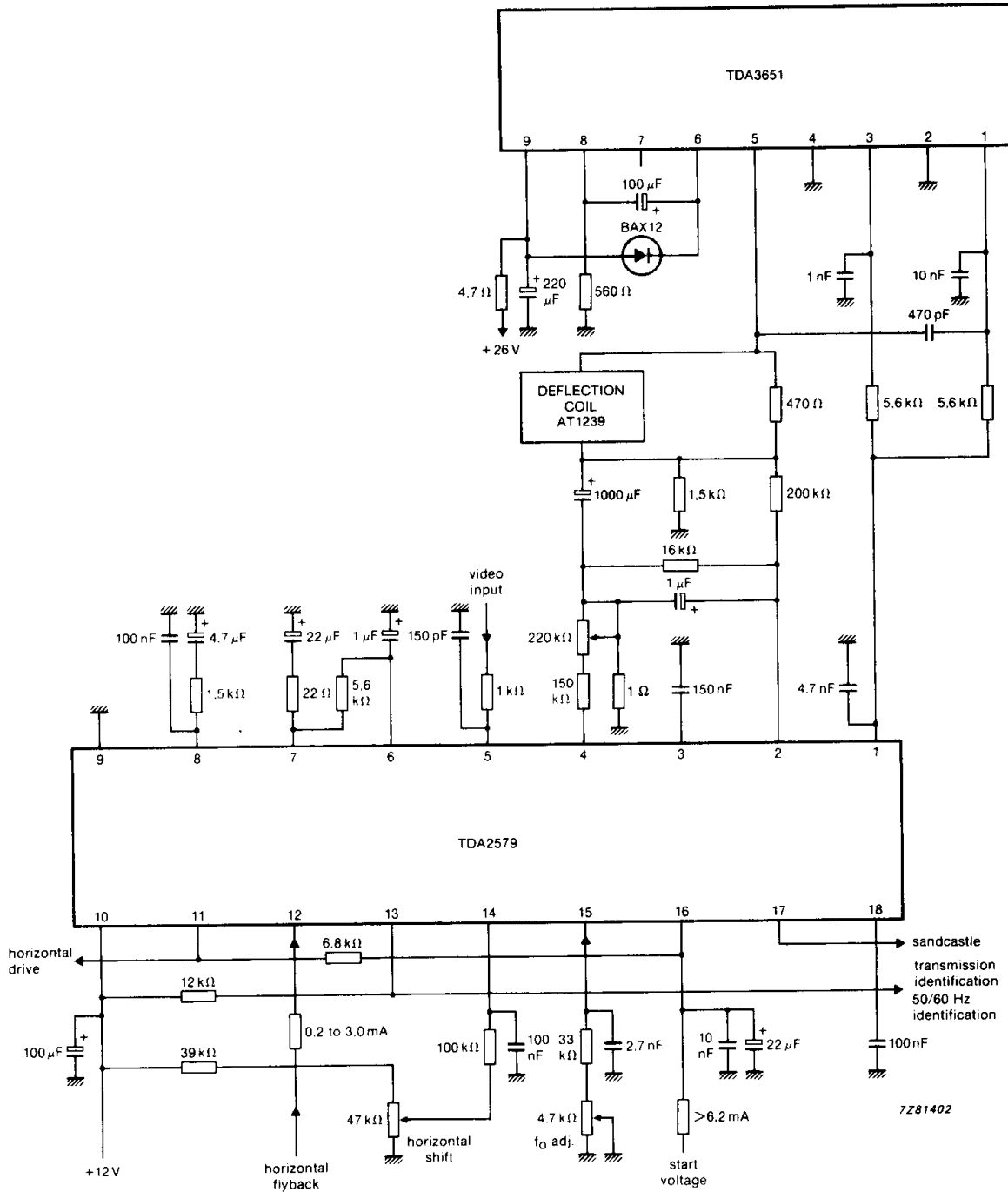

Fig. 8 Application circuit diagram for combination of TDA3651 with TDA2579.