

## Hex-Driver for High Temperature Application

### Description

The hexdriver IC includes 6 non-inverted and current limited output stages with an open collector. Each output can sink 20 mA, parallel output operation is

possible. The digital inputs have Schmitt-trigger function with pull-up current sources to 5 V.

### Features

- Six input comparators with Schmitt-trigger characteristic
- Input clamping current capability to  $\pm 10$  mA
- Integrated protection cells (EMC, ESD, RF) dedicated to all input stages
- Low voltage reset with hysteresis
- ESD protection to human body model:  $\pm 2000$  V (C = 100 pF, R = 1.5 k $\Omega$ )
- Output stages:
  - Short circuit protected with diode
  - Load-dump protected @ 1 k $\Omega$
  - No crosstalk on adjacent channels
  - Clamping current @ -2 mA
  - Jump start possible

Extended Type Number	Package	Remarks
U6807B-FP	SO14	

### Block Diagram

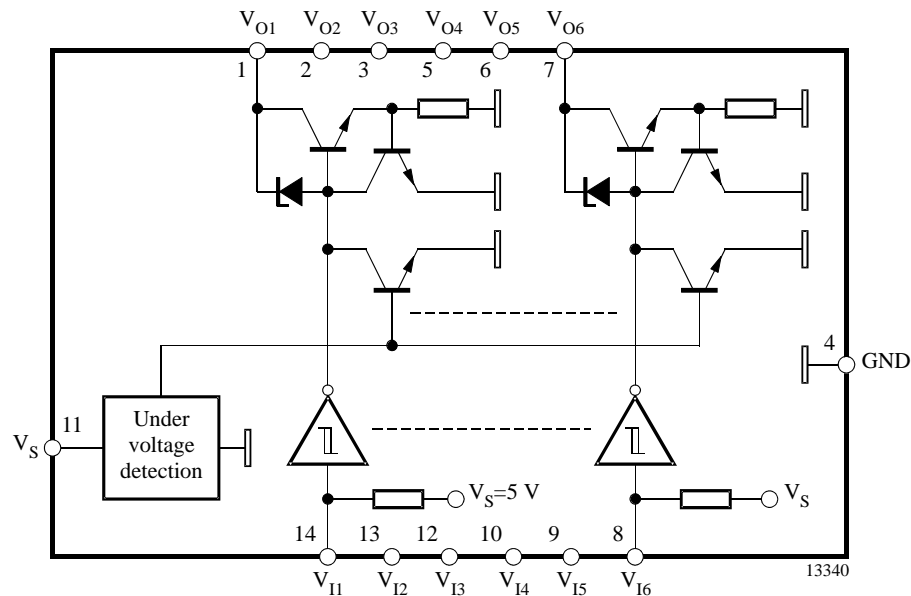

Figure 1.

## Pin Description

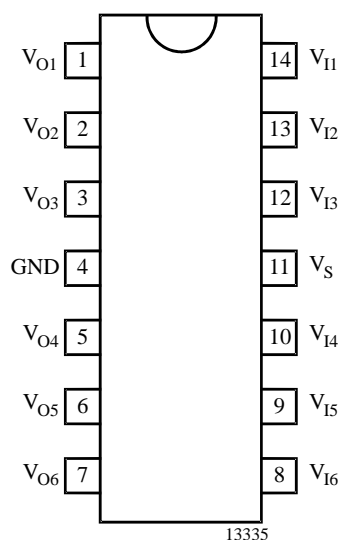

Figure 2. Pinning

Pin	Symbol	Function
1	V <sub>O1</sub>	Output 1
2	V <sub>O2</sub>	Output 2
3	V <sub>O3</sub>	Output 3
4	GND	Ground
5	V <sub>O4</sub>	Output 4
6	V <sub>O5</sub>	Output 5
7	V <sub>O6</sub>	Output 6
8	V <sub>I6</sub>	Input 6
9	V <sub>I5</sub>	Input 5
10	V <sub>I4</sub>	Input 4
11	V <sub>S</sub>	Supply voltage, 5 V
12	V <sub>I3</sub>	Input 3
13	V <sub>I2</sub>	Input 2
14	V <sub>I1</sub>	Input 1

## Basic Circuitry

The integrated circuit, U6805B, requires a stabilized supply voltage ( $V_S = 5\text{ V} \pm 5\%$ ) to comply with its electrical characteristics. An external buffer capacitor of  $C = 100\text{ nF}$  value is recommended. An integrated 14-V Z-diode between  $V_S$  and ground protects the supply pin.

All input stages are provided with an integrated  $250\text{ k}\Omega$  pull-up resistor and can be directly connected to a microcontroller.

All output stages are open collectors each capable of sinking  $20\text{ mA}$ . Recommended external components:

Pull-up resistor,  $R = 1\text{ k}\Omega$

Capacitor to GND,  $C = 470\text{ pF}$ , see figure 3

## Functional Description

### General

ON state: Low level at the input stage activates the corresponding output stage.

OFF state: The internal pull-up resistor gives high level to the input comparator and deactivates the output stage.

7 V Z-diodes between each input pin and GND are capable of  $\pm 10\text{ mA}$  clamping currents without crosstalk on adjacent input stages.

A total clamping current of  $\pm 30\text{ mA}$  should be observed with respect to the power dissipation.

## Current Limitation of the Output Stages

A temperature dependent current limitation between  $25\text{ mA}$  and  $100\text{ mA}$  protects the stages during a short.

An appropriate heat sink assembly with  $R_{thJA} < 100\text{ K/W}$  and/or a further reduction of the maximum ambient temperature is recommended in order to avoid thermal overstress. Depending on the numbers of output stages which may be in short circuit condition these maximum ratings are (with  $R_{thJA} < 120\text{ K/W}$ ):

$T_{amb\ max} \leq 80^\circ\text{C}$  @ 2 channels shorted simultaneously

$T_{amb\ max} \leq 65^\circ\text{C}$  @ 3 channels shorted simultaneously

Refer to hexdriver U6805B if thermal shut down is required.

## Transients and Load-Dump

An integrated 28-V Z-diode protects each output stage against transients and load-dump (Schaffner pulses). With the help of external  $1\text{-k}\Omega$  resistor, the output transistor is capable of the corresponding current which flows during each of these conditions. Apart from that, outputs are short circuit and overload protected.

## Low Voltage Detection

When supply voltage is switched on, a power-on reset pulse is generated internally, which disables all output stages until a defined supply voltage level is reached. The low voltage detection is provided with a hysteresis of  $V_{hyst} = 0.5\text{ V}$  typically.

### Absolute Maximum Ratings

Parameters	Symbol	Value	Unit
Supply voltage	$V_S$	7.0	V
Ambient temperature range *	$T_{amb}$	-40 to +125	°C
Storage temperature range	$T_{stg}$	-50 to +150	°C
Maximum junction temperature	$T_j$	+150	°C

\* To be reduced if 2 or 3 output stages are shorted simultaneously (see “remark” on page 2).

### Thermal Resistance

Parameters	Symbol	Value	Unit
Junction ambient	$R_{thJA}$	120	K/W

### Electrical Characteristics

$V_S = 5\text{ V} \pm 5\%$ ,  $T_{amb} = 25^\circ\text{C}$ , reference point pin 4 (GND), unless otherwise specified, see figures 1 and 3.

Parameters	Test Conditions / Pins	Symbol	Min.	Typ.	Max.	Unit
<b>Supply Pin 11</b>						
Supply voltage		$V_S$	4.75		5.25	V
Supply current	Inputs open	$I_S$	0.8		4.2	mA
	Inputs closed to GND	$I_S$	7		14.5	mA
Low voltage detection threshold	ON	$V_{TH(ON)}$	3.7		4.6	V
	OFF	$V_{TH(OFF)}$	3.0		3.8	V
Low voltage hysteresis		$V_{hyst}$	0.55		1.05	V
<b>Inputs Pins 8, 9, 10, 12, 13 and 14</b>						
Z-diode protection voltage		$V_I$	6.7		8.5	V
Z-diode clamping current		$I_I$			$\pm 10$	mA
Pull-up resistor		$R_I$	170	250	305	k $\Omega$
Switching threshold	OFF	$V_I$		3.3		V
	ON	$V_I$		1.8		V
Hysteresis		$V_{hyst}$		1.5		V
<b>Outputs Pins 1, 2, 3, 5, 6 and 7</b>						
Z-diode protection voltage		$V_O$	26.5			V
Integrated capacitor				5		pF
Leakage current		$I_{Leak}$			2.5	$\mu\text{A}$
Saturation voltage ( $I = 20\text{ mA}$ )		$V_{Sat}$			0.7	V
Current limitation		$I_{limit}$	25			mA
Propagation delay (470 pF, 1 k $\Omega$ , 20 V)		$t_d$			5	$\mu\text{s}$

## Application Circuit

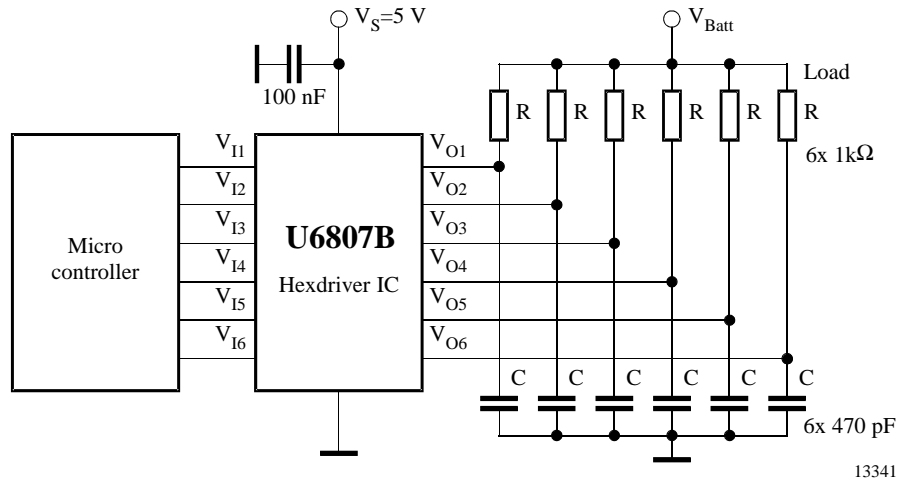
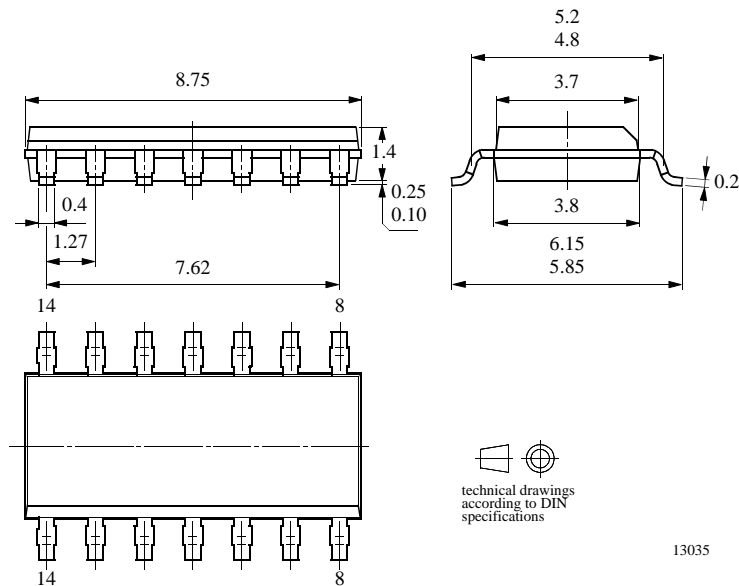

Figure 3. Application schematic

## Package Information

Package SO14  
Dimensions in mm



## Ozone Depleting Substances Policy Statement

It is the policy of **TEMIC TELEFUNKEN microelectronic GmbH** to

1. Meet all present and future national and international statutory requirements.
2. Regularly and continuously improve the performance of our products, processes, distribution and operating systems with respect to their impact on the health and safety of our employees and the public, as well as their impact on the environment.

It is particular concern to control or eliminate releases of those substances into the atmosphere which are known as ozone depleting substances (ODSs).

The Montreal Protocol (1987) and its London Amendments (1990) intend to severely restrict the use of ODSs and forbid their use within the next ten years. Various national and international initiatives are pressing for an earlier ban on these substances.

**TEMIC TELEFUNKEN microelectronic GmbH** semiconductor division has been able to use its policy of continuous improvements to eliminate the use of ODSs listed in the following documents.

1. Annex A, B and list of transitional substances of the Montreal Protocol and the London Amendments respectively
2. Class I and II ozone depleting substances in the Clean Air Act Amendments of 1990 by the Environmental Protection Agency (EPA) in the USA
3. Council Decision 88/540/EEC and 91/690/EEC Annex A, B and C (transitional substances) respectively.

**TEMIC** can certify that our semiconductors are not manufactured with ozone depleting substances and do not contain such substances.

**We reserve the right to make changes to improve technical design and may do so without further notice.**

Parameters can vary in different applications. All operating parameters must be validated for each customer application by the customer. Should the buyer use TEMIC products for any unintended or unauthorized application, the buyer shall indemnify TEMIC against all claims, costs, damages, and expenses, arising out of, directly or indirectly, any claim of personal damage, injury or death associated with such unintended or unauthorized use.

TEMIC TELEFUNKEN microelectronic GmbH, P.O.B. 3535, D-74025 Heilbronn, Germany  
Telephone: 49 (0)7131 67 2831, Fax number: 49 (0)7131 67 2423