

Preliminary W83194R-37/-58



100 MHZ AGP CLOCK FOR VIA CHIPSET

1.0 GENERAL DESCRIPTION

The W83194R-37/-58 is a Clock Synthesizer for VIA chipset. W83194R-37 provides all clocks required for high-speed RISC or CISC microprocessor such as Intel PentiumPro, AMD or Cyrix. Eight different frequencies of CPU, W83194R-58 provides all clocks required for high-speed RISC or CISC microprocessor such as Intel PentiumII and also provides 16 different frequencies of CPU clocks by software setting (additional register0 bit2). AGP and PCI clocks are externally selectable with smooth transitions. The W83194R-37/-58 provides AGP clocks especially for clone chipset, and makes SDRAM in synchronous frequency with CPU or AGP clocks.

The W83194R-37/-58 provides I²C serial bus interface to program the registers to enable or disable each clock outputs and choose the 0.25%, 0.5% or 0.5%, 1.5% center type spread spectrum to reduce EMI.

The W83194R-37/-58 accepts a 14.318 MHz reference crystal as its input and runs on a 3.3V supply. High drive PCI and SDRAM CLOCK outputs typically provide greater than 1V /nS slew rate into 30 pF loads. CPU CLOCK outputs typically provide better than 1V /nS slew rate into 20 pF loads as maintaining 50 ±5% duty cycle. The fixed frequency outputs as REF, 24 MHz, and 48 MHz provide better than 0.5V /nS slew rate.

2.0 FEATURES

- Supports Pentium™, Pentium™ Pro, Pentium™ II, AMD and Cyrix CPUs with I²C.
- 4 CPU clocks
- 12 SDRAM clocks for 3 DIMs
- Two AGP clocks
- 6 PCI synchronous clocks.
- Optional single or mixed supply:
(VDD = VDDq3 = VDDq2 = VDDq2b = 3.3V) or (VDD = VDDq3 = VDDq2 = 3.3V, VDDq2b = 2.5V)
- Skew from CPU to PCI clock -1 to 4 nS, center 2.6 nS, AGP to CPU sync. skew 0 nS (250 pS)
- SDRAM frequency synchronous to CPU or AGP clocks
- Smooth frequency switch with selections from 60 to 100 MHz CPU (-37) and 66 to 150 MHz (-58)
- I²C 2-Wire serial interface and I²C read back
- ±0.5% or ±1.5% (-37) and 0.25%, 0.5% (-58) center type spread spectrum to reduce EMI
- Programmable registers to enable/stop each output and select modes (mode as Tri-state or Normal)
- MODE pin for power Management
- 48 MHz for USB
- 24 MHz for super I/O
- Packaged in 48-pin SSOP

Preliminary W83194R-37/-58



3.0 PIN CONFIGURATION

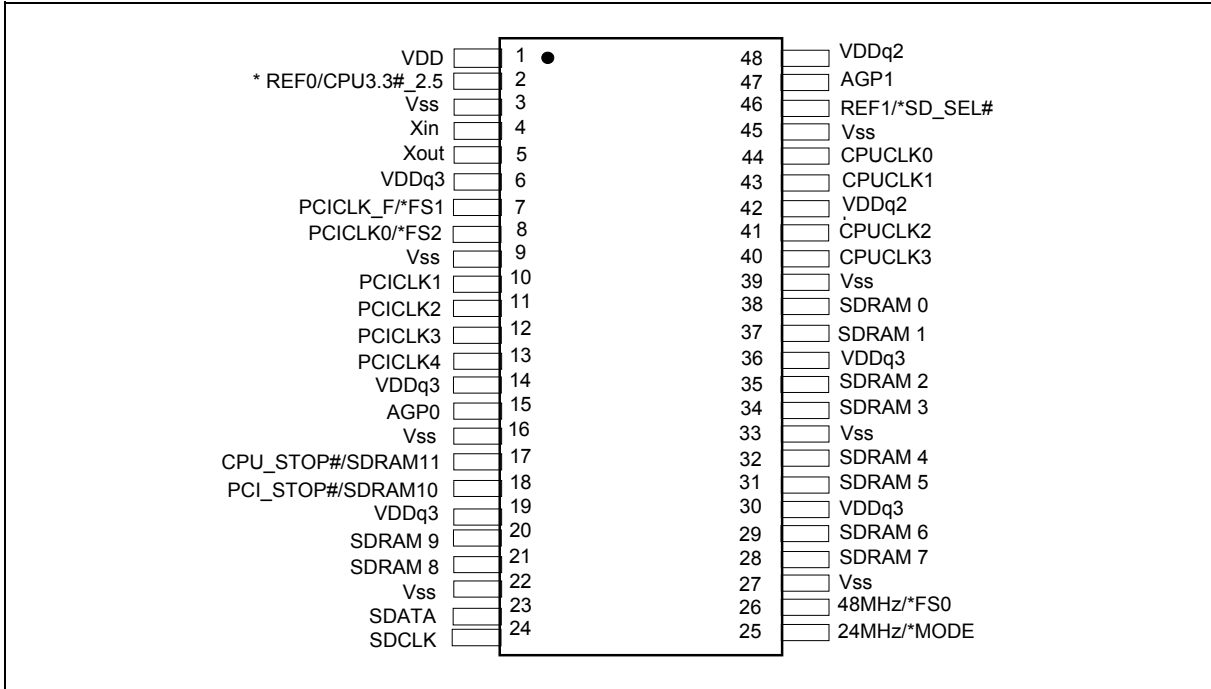

4.0 BLOCK DIAGRAM

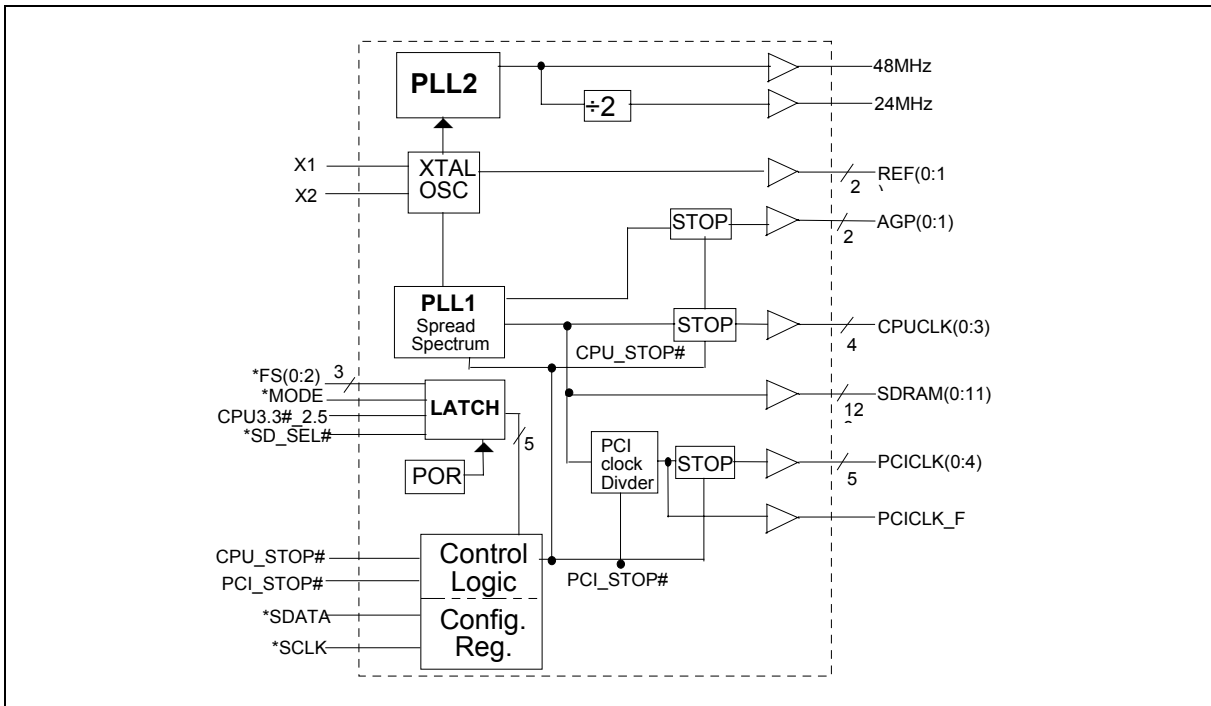



5.0 PIN DESCRIPTION

IN - Input

OUT - Output

I/O - Bi-directional Pin

- Active Low

* - Internal 250kΩ pull-up

5.1 Crystal I/O

SYMBOL	PIN	I/O	FUNCTION
Xin	4	IN	Crystal input with internal loading capacitors and feedback resistors.
Xout	5	OUT	Crystal output at 14.318 MHz nominally.

5.2 CPU, SDRAM, PCI Clock Outputs

SYMBOL	PIN	I/O	FUNCTION
CPUCLK [0:3]	40, 41, 43, 44	OUT	Low skew (< 250 pS) clock outputs for host frequencies such as CPU, Chipset and Cache. VDDq2b is the supply voltage for these outputs.
AGP[0:1]	15, 47	OUT	Accelerate Graphic Port clock outputs
SDRAM11/ CPU_STOP#	17	I/O	If MODE = 1 (default), then this pin is a SDRAM clock buffered output of the crystal. If MODE = 0, then this pin is CPU_STOP# input used in power management mode for synchronously stopping the all CPU clocks.
SDRAM10/ PCI_STOP#	18	I/O	If MODE = 1 (default), then this pin is a SDRAM clock output. If MODE = 0, then this pin is PCI_STOP # and used in power management mode for synchronously stopping the all PCI clocks.
SDRAM [0:9]	20, 21, 28, 29, 31, 32, 34, 35, 37, 38	O	SDRAM clock outputs which have the same frequency as CPU clocks.
PCICLK_F/ *FS1	7	I/O	Latched input for FS1 at initial power up for H/W selecting the output frequency of CPU, SDRAM and PCI clocks. Free running PCI clock during normal operation.
PCICLK 0/ *FS2	8	I/O	Latched input for FS2 at initial power up for H/W selecting the output frequency of CPU, SDRAM and PCI clocks. PCI clock during normal operation.
PCICLK [1:4]	10, 11, 12, 13	OUT	Low skew (< 250 pS) PCI clock outputs.



5.3 I²C Control Interface

SYMBOL	PIN	I/O	FUNCTION
SDATA	23	I/O	Serial data of I ² C 2-wire control interface
SDCLK	24	IN	Serial clock of I ² C 2-wire control interface

5.4 Fixed Frequency Outputs

SYMBOL	PIN	I/O	FUNCTION
REF0/ CPU3.3#_2.5	2	I/O	Internal 250 K Ω pull-up. Latched input for CPU3.3#_2.5 at initial power up. Reference clock during normal operation. Latched high - VDDq2b = 2.5V Latched low - VDDq2b = 3.3V
REF1/*SD_SEL#	46	I/O	Internal 250 K Ω pull-up. Latched input at Power On selects either CPU(SDSEL = 1) or AGP(SD_SEL = 0) frequencies for SDRAM clock outputs.
24MHz/ *MODE	25	I/O	Internal 250 K Ω pull-up. Latched input for MODE at initial power up. 24 MHz output for super I/O during normal operation.
48MHz/ *FS0	26	I/O	Internal 250 K Ω pull-up. Latched input for FS0 at initial power up for H/W selecting the output frequency of CPU, SDRAM and PCI clocks. 48 MHz output for USB during normal operation.

5.5 Power Pins

SYMBOL	PIN	FUNCTION
VDD	1	Power supply for Ref [0:1] crystal and core logic.
VDDq2	42	Power supply for AGP1 and REF1 output, either 2.5V or 3.3V.
VDDq2b	48	Power supply for CPUCLK[0:3], either 2.5V or 3.3V.
VDDq3	6, 14, 19, 30, 36	Power supply for SDRAM, PCICLK and 48/24 MHz outputs.
Vss	3, 9, 16, 22, 27, 33, 39, 45	Circuit Ground.

Preliminary W83194R-37/-58



6.0 FREQUENCY SELECTION BY HARDWARE

6.1 W83194R-37 Frequency Selection Table

FS2	FS1	FS0	CPU (MHz)	SDRAM (MHz)		PCI (MHz)	AGP (MHz)	REF (MHz)
				SD_SEL = 1	SD_SEL = 0			
0	0	0	60	60	60	30	60	14.318
0	0	1	66.8	66.8	66.8	33.4	66.8	14.318
0	1	0	68.5	68.5	68.5	34.25	68.5	14.318
0	1	1	75	75	75	37.5	75	14.318
1	0	0	75	75	60	30	60	14.318
1	0	1	83.3	83.3	66.6	33.3	66.6	14.318
1	1	0	95	95	63.4	31.7	63.4	14.318
1	1	1	100	100	66.6	33.3	66.6	14.318

6.2 W83194R-58 Frequency Selection Table

FS2	FS1	FS0	CPU (MHz)	SDRAM (MHz)		PCI (MHz)	AGP (MHz)	REF (MHz)
				SD_SEL = 1	SD_SEL = 0			
0	0	0	112	112	74.7	37.3	74.7	14.318
0	0	1	66.8	66.8	66.8	33.4	66.8	14.318
0	1	0	124	124	82.5	41.3	82.5	14.318
0	1	1	75	75	75	37.5	75	14.318
1	0	0	133.3	133.3	88.7	44.3	88.7	14.318
1	0	1	83.3	83.3	66.6	33.3	66.6	14.318
1	1	0	95.25	95.25	63.5	31.75	63.5	14.318
1	1	1	100.2	100.2	66.8	33.4	66.8	14.318

7.0 CPU 3.3#_2.5 BUFFER SELECTION

CPU 3.3#_2.5 (Pin 2) Input Level	CPU Operate at
1	V _{DD} = 2.5V
0	V _{DD} = 3.3V



8.0 FUNCTION DESCRIPTION

8.1 Power Management Functions

All clocks can be individually enabled or disabled via the 2-wire control interface. On power up, external circuitry should allow 3 mS for the VCO to stabilize prior to enabling clock outputs to assure correct pulse widths. When MODE = 0, pins 18 and 17 are inputs (PCI_STOP#), (CPU_STOP#), when MODE = 1, these functions are not available. A particular clock could be enabled as both the 2-wire serial control interface and one of these pins indicate that it should be enabled.

The W83194R-37/-58 may be disabled in the low state according to the following table in order to reduce power consumption. All clocks are stopped in the low state, but maintain a valid high period on transitions from running to stop. The CPU and PCI clocks transform between running and stop by waiting for one positive edge on PCICLK_F followed by negative edge on the clock of interest, after which high levels of the output are either enabled or disabled.

CPU_STOP#	PCI_STOP#	CPU & AGP	PCI	OTHER CLKs	XTAL & VCOs
0	0	Low	Low	Running	Running
0	1	Low	Running	Running	Running
1	0	Running	Low	Running	Running
1	1	Running	Running	Running	Running

8.2 2-Wire I²C Control Interface

The clock generator is a slave I²C component which can be read back the data stored in the latches for verification. All proceeding bytes must be sent to change one of the control bytes. The 2-wire control interface allows each clock output individually enabled or disabled. On power up, the W83194R-37/-58 initializes with default register settings, and then it optional to use the 2-wire control interface.

The SDATA signal only changes when the SDCLK signal is low, and is stable when SDCLK is high during normal data transfer. There are only two exceptions. One is a high-to-low transition on SDATA while SDCLK is high used to indicate the beginning of a data transfer cycle. The other is a low-to-high transition on SDATA while SDCLK is high used to indicate the end of a data transfer cycle. Data is always sent as complete 8-bit bytes followed by an acknowledge generated.

Byte writing starts with a start condition followed by 7-bit slave address [1101 0010], command code checking [0000 0000], and byte count checking. After successful reception of each byte, an acknowledge (low) on the SDATA wire will be generated by the clock chip. Controller can start to write to internal I²C registers after the string of data. The sequence order is as follows:

Bytes sequence order for I²C controller:

Clock Address A(6:0) & R/W	Ack	8 bits dummy Command code	Ack	8 bits dummy Byte count	Ack	Byte0,1,2... until Stop
----------------------------	-----	---------------------------	-----	-------------------------	-----	-------------------------

Set R/W to 1 when read back the data sequence is as follows:

Clock Address A(6:0) & R/W	Ack	Byte 0	Ack	Byte 1	Ack	Byte2, 3, 4... until Stop
----------------------------	-----	--------	-----	--------	-----	---------------------------

Preliminary W83194R-37/-58



8.3 Serial Control Registers

The Pin column lists the affected pin number and the @PowerUp column gives the state at true power up. Registers are set to the values shown only on true power up. "Command Code" byte and "Byte Count" byte must be sent following the acknowledge of the Address Byte. Although the data (bits) in these two bytes are considered "don't care", they must be sent and will be acknowledge. After that, the below described sequence (Register 0, Register 1, Register 2,) will be valid and acknowledged.

8.3.1 Register 0: CPU Frequency Select Register

BIT	@POWERUP	PIN	DESCRIPTION
7	0	-	0 = ±1.5% Spread Spectrum Modulation (W83194R-37) 1 = ±0.5% Spread Spectrum Modulation 0 = ±0.25% Center Type Spread Spectrum Modulation (W83194R-58) 1 = ±0.5% Center Type Spread Spectrum Modulation
6	0	-	SSEL2 (Frequency table selection by software via I ² C)
5	0	-	SSEL1 (Frequency table selection by software via I ² C)
4	0	-	SSEL0 (Frequency table selection by software via I ² C)
3	0	-	0 = Selection by hardware 1 = Selection by software I ² C - Bit 6:4
2	0	-	SSEL3 (Frequency table selection by software via I ² C for W83194R-58)
2	0	-	0 = Spread spectrum center type (W83194R-37) 1 = Spread spectrum down type (W83194R-37)
1	0	-	0 = Normal 1 = Spread Spectrum enabled
0	0	-	0 = Running 1 = Tristate all outputs

W83194R-37 Frequency table selection by software via I²C

SSEL2	SSEL1	SSEL0	CPU(MHz)	SDRAM (MHz)		PCI (MHz)	AGP (MHz)	REF (MHz)
				SD_SEL=1	SD_SEL=0			
0	0	0	60	60	60	30	60	14.318
0	0	1	66.8	66.8	66.8	33.4	66.8	14.318
0	1	0	68.5	68.5	68.5	34.25	68.5	14.318
0	1	1	75	75	75	37.5	75	14.318
1	0	0	75	75	60	30	60	14.318
1	0	1	83.3	83.3	66.6	33.3	66.6	14.318
1	1	0	95	95	63.4	31.7	63.4	14.318
1	1	1	100	100	66.6	33.3	66.6	14.318

Preliminary W83194R-37/-58



W83194R-58 Frequency table selection by software via I²C

SSEL2	SSEL1	SSEL0	Register0 Bit2	CPU	SDRAM (MHz)		PCI	AGP	REF
			SSEL3	(MHz)	SD_SEL=1	SD_SEL=0	(MHz)	(MHz)	(MHz)
0	0	0	0	112	112	74.7	37.3	74.7	14.318
0	0	1	0	66.8	66.8	66.8	33.4	66.8	14.318
0	1	0	0	124	124	82.7	41.3	82.7	14.318
0	1	1	0	75	75	75	37.5	75	14.318
1	0	0	0	133.3	133.3	88.7	44.3	88.7	14.318
1	0	1	0	83.3	83.3	66.6	33.3	66.6	14.318
1	1	0	0	95.25	95.25	63.5	31.75	63.5	14.318
1	1	1	0	100.2	100.2	66.8	33.4	66.8	14.318
0	0	0	1	103	103	68.7	34.3	68.7	14.318
0	0	1	1	112	112	74.7	37.3	74.7	14.318
0	1	0	1	115	115	76.6	38.3	76.6	14.318
0	1	1	1	120	120	80	40	80	14.318
1	0	0	1	124	124	82	31	82	14.318
1	0	1	1	133.3	133.3	66.6	33.3	66.6	14.318
1	1	0	1	140	140	70	35	70	14.318
1	1	1	1	150	150	75	37.5	75	14.318

FUNCTION TABLE

FUNCTION DESCRIPTION	OUTPUTS				
	CPU	PCI	SDRAM	REF	IOAPIC
TRI-STATE	Hi-Z	Hi-Z	Hi-Z	Hi-Z	Hi-Z
NORMAL	See table	See table	CPU	14.318	14.318

8.3.2 Register 1: CPU, 48/24 MHz Clock Register (1 = Active, 0 = Inactive)

BIT	@POWERUP	PIN	DESCRIPTION
7	1	-	Reserved
6	1	-	Reserved
5	1	-	Reserved
4	1	-	Reserved

Preliminary W83194R-37/-58



8.3.2 Register 1: CPU, 48/24 MHz Clock Register (1 = Active, 0 = Inactive), continued

BIT	@POWERUP	PIN	DESCRIPTION
3	1	40	CPUCLK3 (Active/Inactive)
2	1	41	CPUCLK2 (Active/Inactive)
1	1	43	CPUCLK1 (Active/Inactive)
0	1	44	CPUCLK0 (Active/Inactive)

8.3.3 Register 2: PCI Clock Register (1 = Active, 0 = Inactive)

BIT	@POWERUP	PIN	DESCRIPTION
7	x	-	Reserved
6	1	7	PCICLK_F (Active/Inactive)
5	1	15	AGP0 (Active/Inactive)
4	1	14	PCICLK4 (Active/Inactive)
3	1	12	PCICLK3 (Active/Inactive)
2	1	11	PCICLK2 (Active/Inactive)
1	1	10	PCICLK1 (Active/Inactive)
0	1	8	PCICLK0 (Active/Inactive)

8.3.4 Register 3: SDRAM Clock Register (1 = Active, 0 = Inactive)

BIT	@POWERUP	PIN	DESCRIPTION
7	1	28	SDRAM7 (Active/Inactive)
6	1	29	SDRAM6 (Active/Inactive)
5	1	31	SDRAM5 (Active/Inactive)
4	1	32	SDRAM4 (Active/Inactive)
3	1	34	SDRAM3 (Active/Inactive)
2	1	35	SDRAM2 (Active/Inactive)
1	1	37	SDRAM1 (Active/Inactive)
0	1	38	SDRAM0 (Active/Inactive)

8.3.5 Register 4: Additional SDRAM Clock Register (1 = Active, 0 = Inactive)

BIT	@POWERUP	PIN	DESCRIPTION
7	x	-	Reserved
6	x	-	Reserved

Preliminary W83194R-37/-58



8.3.5 Register 4: Additional SDRAM Clock Register (1 = Active, 0 = Inactive), continued

BIT	@POWERUP	PIN	DESCRIPTION
5	x	-	Reserved
4	x	-	Reserved
3	1	17	SDRAM11 (Active/ Inactive)
2	1	18	SDRAM10 (Active/ Inactive)
1	1	20	SDRAM9 (Active/ Inactive)
0	1	21	SDRAM8 (Active/ Inactive)

8.3.6 Register 5: Peripheral Control (1 = Active, 0 = Inactive)

BIT	@POWERUP	PIN	DESCRIPTION
7	x	-	Reserved
6	x	-	Reserved
5	x	-	Reserved
4	1	47	AGP1 (Active/ Inactive)
3	x	-	Reserved
2	x	-	Reserved
1	1	46	REF1 (Active/ Inactive)
0	1	2	REF0 (Active/ Inactive)

8.3.7 Register 6: Reserved Register

BIT	@POWERUP	PIN	DESCRIPTION
7	x	-	Reserved
6	x	-	Reserved
5	x	-	Reserved
4	x	-	Reserved
3	x	-	Reserved
2	x	-	Reserved
1	x	-	Reserved
0	x	-	Reserved



9.0 SPECIFICATIONS

9.1 Absolute Maximum Ratings

Stresses greater than those listed in this table may cause permanent damage to the device. Precautions should be taken to avoid application of any voltage higher than the maximum rated voltages to this circuit. Maximum conditions for extended periods may affect reliability. Unused inputs must always be tied to an appropriate logic voltage level (Ground or VDD).

PARAMETER	SYMBOL	RATING
Voltage on any pin with respect to GND	VDD, VIN	- 0.5V to +7.0V
Storage Temperature	TSTG	- 65°C to +150°C
Ambient Temperature	TB	- 55°C to +125°C
Operating Temperature	TA	0°C to +70°C

Note: Exposure to conditions beyond those listed under Absolute Maximum Ratings may adversely affect the life and reliability of the device.

9.2 AC Characteristics

VDDq2 = VDD = VDDq3 = 3.3V ±5%, VDDq2b = 2.375V~2.9V, TA = 0 °C to +70 °C

PARAMETER	SYM.	MIN.	TYP.	MAX.	UNITS	TEST CONDITIONS
Output Duty Cycle		45	50	55	%	Measured at 1.5V
CPU/SDRAM to PCI Offset	tOFF	1		4	nS	15 pF Load Measured at 1.5V
Skew (CPU-CPU), (PCI-PCI), (SDRAM-SDRAM)	tSKEW			250	pS	15 pF Load Measured at 1.5V
CPU/SDRAM Cycle to Cycle Jitter	tCCJ			±250	pS	
CPU/SDRAM Absolute Jitter	tJA			500	pS	
Jitter Spectrum 20 dB Bandwidth from Center	BWJ			500	KHz	
Output Rise (0.4V–2.0V) & Fall (2.0V–0.4V) Time	tTLH tTHL	0.4		1.6	nS	15 pF Load on CPU and PCI outputs
Overshoot/Undershoot Beyond Power Rails	Vover	0.7		1.5	V	22 Ω at source of 8 inch PCB run to 15 pF load
Ring Back Exclusion	VRBE	0.7		2.1	V	Ring Back must not enter this range.

Preliminary W83194R-37/-58



9.3 DC Characteristics

VDDq2 = VDD = VDDq3 = 3.3V ±5%, VDDq2b = 2.375V~2.9V, TA = 0 °C to +70 °C

PARAMETER	SYM.	MIN.	TYP.	MAX.	UNITS	TEST CONDITIONS
Input Low Voltage	V _{IL}			0.8	V _{dc}	
Input High Voltage	V _{IH}	2.0			V _{dc}	
Input Low Current	I _{IL}			-66	μA	
Input High Current	I _{IH}			5	μA	
Output Low Voltage IOL = 4 mA	V _{OL}			0.4	V _{dc}	All outputs
Output High Voltage IOH = 4 mA	V _{OH}	2.4			V _{dc}	All outputs using 3.3V power
Tri-State leakage Current	I _{OZ}			10	μA	
Dynamic Supply Current for VDD + VDDq3	I _{DD3}				mA	CPU = 66.6 MHz PCI = 33.3 MHz with load
Dynamic Supply Current for VDDq2 + VDDq2b	I _{DD2}				mA	Same as above
CPU Stop Current for VDD + VDDq3	I _{CPUS3}				mA	Same as above
CPU Stop Current for VDDq2 + VDDq2b	I _{CPUS2}				mA	Same as above
PCI Stop Current for VDD + VDDq3	I _{PD3}				mA	

9.4 Buffer Characteristics

9.4.1 Type 1 Buffer for CPU (0:3)

PARAMETER	SYMBOL	MIN.	TYP.	MAX.	UNITS	TEST CONDITIONS
Pull-up Current Min.	I _{OH} (min.)	-27			mA	V _{out} = 1.0V
Pull-up Current Max.	I _{OH} (max.)			-27	mA	V _{out} = 2.0V
Pull-down Current Min.	I _{OL} (min.)				mA	V _{out} = 1.2V
Pull-down Current Max.	I _{OL} (max.)			27	mA	V _{out} = 0.3V
Rise/Fall Time Min. Between 0.4V and 2.0V	TRF (min.)	0.4			nS	10 pF Load
Rise/Fall Time Max. Between 0.4V and 2.0V	TRF (max.)			1.6	nS	20 pF Load



9.4.2 Type 2 Buffer for IOAPIC

PARAMETER	SYMBOL	MIN.	TYP.	MAX.	UNITS	TEST CONDITIONS
Pull-up Current Min.	IOH (min.)				mA	Vout = 1.4V
Pull-up Current Max.	IOH (max.)			-29	mA	Vout = 2.7V
Pull-down Current Min.	IOL (min.)				mA	Vout = 1.0V
Pull-down Current Max.	IOL (max.)			28	mA	Vout = 0.2V
Rise/Fall Time Min. Between 0.7V and 1.7V	TRF (min.)	0.4			nS	10 pF Load
Rise/Fall Time Max. Between 0.7V and 1.7V	TRF (max.)			1.8	nS	20 pF Load

9.4.3 Type 3 Buffer for REF(0:1), 24 MHz, 48 MHz

PARAMETER	SYMBOL	MIN.	TYP.	MAX.	UNITS	TEST CONDITIONS
Pull-up Current Min.	IOH (min.)	-29			mA	Vout = 1.0V
Pull-up Current Max.	IOH (max.)			-23	mA	Vout = 3.135V
Pull-down Current Min.	IOL (min.)	29			mA	Vout = 1.95V
Pull-down Current Max.	IOL (max.)				mA	Vout = 0.4V
Rise/Fall Time Min. Between 0.8V and 2.0V	TRF (min.)	1.0			nS	10 pF Load
Rise/Fall Time Max. Between 0.8V and 2.0V	TRF (max.)			4.0	nS	20 pF Load

9.4.4 Type 4 Buffer for REF0 and SDRAM (0:11)

PARAMETER	SYMBOL	MIN.	TYP.	MAX.	UNITS	TEST CONDITIONS
Pull-up Current Min.	IOH (min.)				mA	Vout = 1.65V
Pull-up Current Max.	IOH (max.)			-46	mA	Vout = 3.135V
Pull-down Current Min.	IOL (min.)				mA	Vout = 1.65V
Pull-down Current Max.	IOL (max.)			53	mA	Vout = 0.4V
Rise/Fall Time Min. Between 0.8V and 2.0V	TRF (min.)	0.5			nS	20 pF Load
Rise/Fall Time Max. Between 0.8V and 2.0V	TRF (max.)			1.3	nS	30 pF Load



9.4.5 Type 5 Buffer for PCICLK(0:4,F)

PARAMETER	SYM.	MIN.	TYP.	MAX.	UNITS	TEST CONDITIONS
Pull-up Current Min.	IOH (min.)	-33			mA	Vout = 1.0V
Pull-up Current Max.	IOH (max.)			-33	mA	Vout = 3.135V
Pull-down Current Min.	IOL (min.)	30			mA	Vout = 1.95V
Pull-down Current Max.	IOL (max.)			38	mA	Vout = 0.4V
Rise/Fall Time Min. Between 0.8V and 2.0V	TRF (min.)	0.5			nS	15 pF Load
Rise/Fall Time Max. Between 0.8V and 2.0V	TRF (max.)			2.0	nS	30 pF Load

10.0 POWER MANAGEMENT TIMING

10.1 CPU_STOP# Timing Diagram

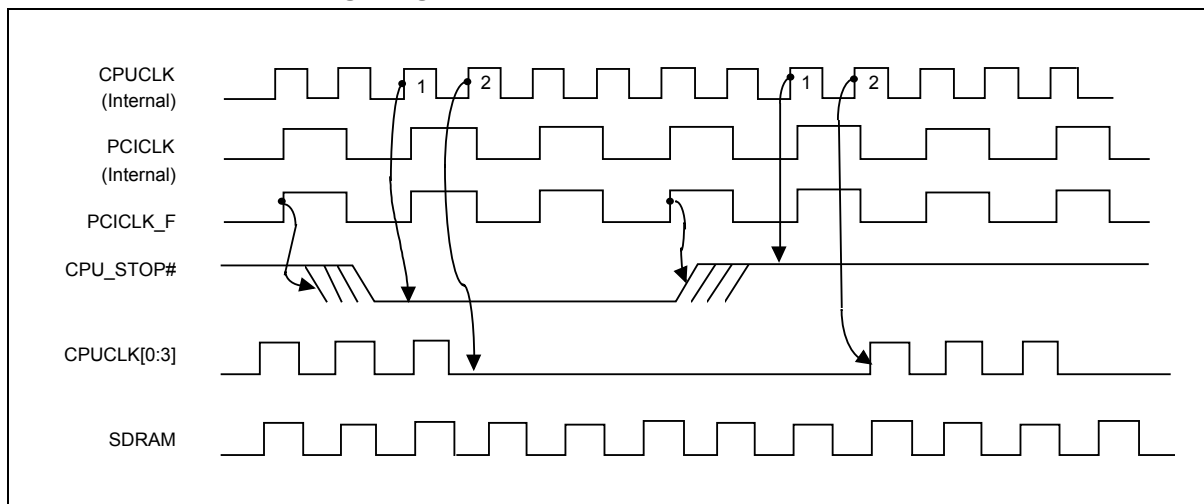

For synchronous Chipset, CPU_STOP# pin is a synchronous "active low" input pin used to stop the CPU clocks for low power operation. This pin is asserted synchronously by the external control logic at the rising edge of free running PCI clock(PCICLK_F). All other clocks will continue to run while the CPU clocks are stopped. The CPU clocks will always be stopped in a low state and resume output with full pulse width. In this case, CPU "clocks on latency" is less than 2 CPU clocks and clocks off latency is less than 2 CPU clocks.



10.2 PCI_STOP# Timing Diagram

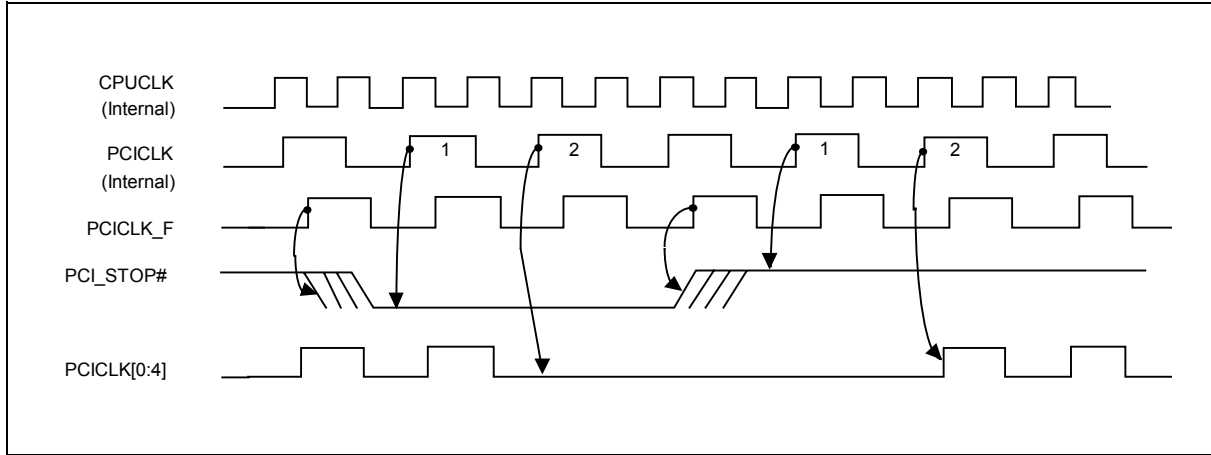

For synchronous Chipset, PCI_STOP# pin is a synchronous "active low" input pin used to stop the PCICLK [0:4] for low power operation. This pin is asserted synchronously by the external control logic at the rising edge of free running PCI clock (PCICLK_F). All other clocks will continue to run while the PCI clocks are stopped. The PCI clocks will always be stopped in a low state and resume output with full pulse width. In this case, PCI "clocks on latency" is less than 1 PCI clocks and clocks off latency is less than 1 PCI clocks.

11.0 OPERATION OF DUAL FUNCTION PINS

Pins 2, 7, 8, 25 and 26 are dual function pins and are used for selecting different functions in this device (see Pin description). During power up, these pins are in input mode (see Figure 1), therefore, and are considered input select pins. When VDD reaches 2.5V, the logic level that is present on these pins are latched into their appropriate internal registers. Once the correct information are properly latched, these pins will change into output pins and will be pulled low by default. At the end of the power up timer (within 3 mS) outputs starts to toggle at the specified frequency.

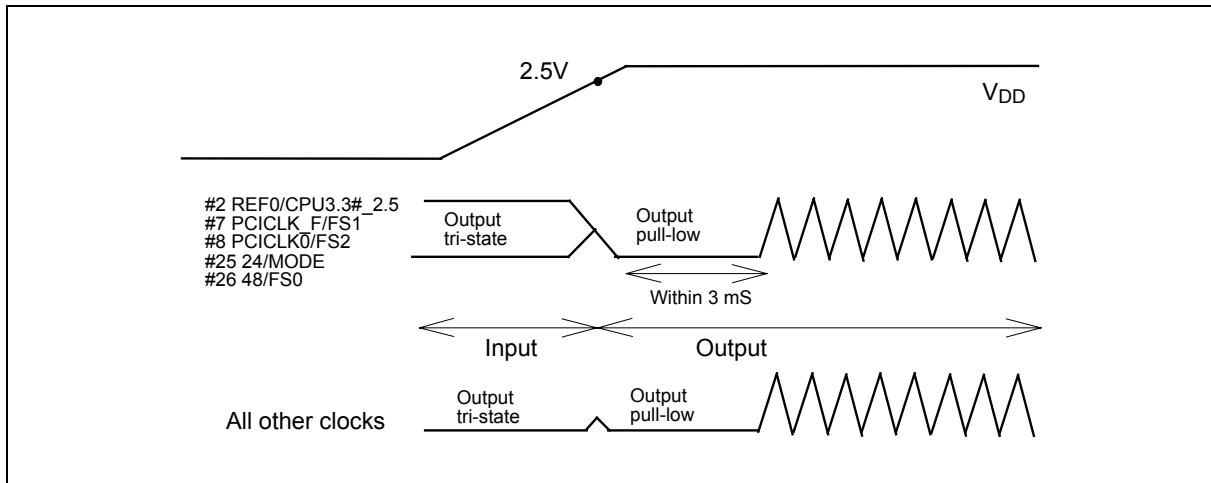

Preliminary W83194R-37/-58



Each of these pins are a large pull-up resistor (250 K Ω @3.3V) inside. The default state will be logic 1, but the internal pull-up resistor may be too large when long traces or heavy load appear on these dual function pins. Under these conditions, an external 10 K Ω resistor is recommended to be connected to V_{DD} if logic 1 is expected. Otherwise, the 10 K Ω resistor is connected to ground if a logic 0 is desired. The 10 K Ω resistor should be placed before the series terminating resistor. Note that these logic will only be latched at initial power on.

If optional EMI reducing capacitor are needed, they should be placed as close to the series terminating resistor as possible and after the series terminating resistor. These capacitor has typical values ranging from 4.7 pF to 22 pF.

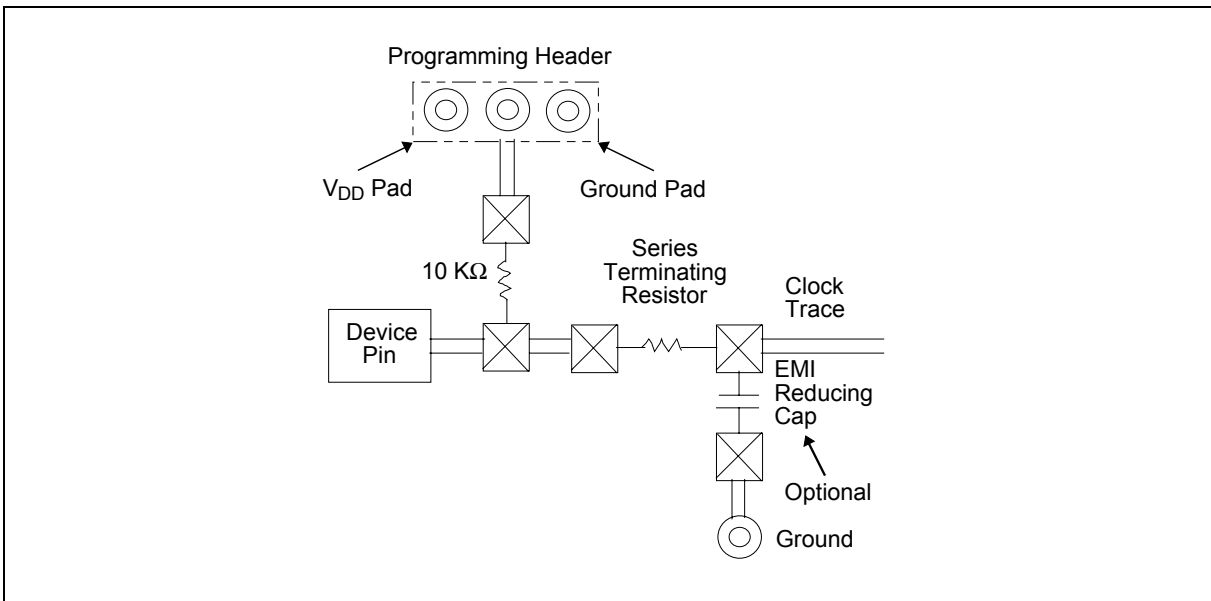
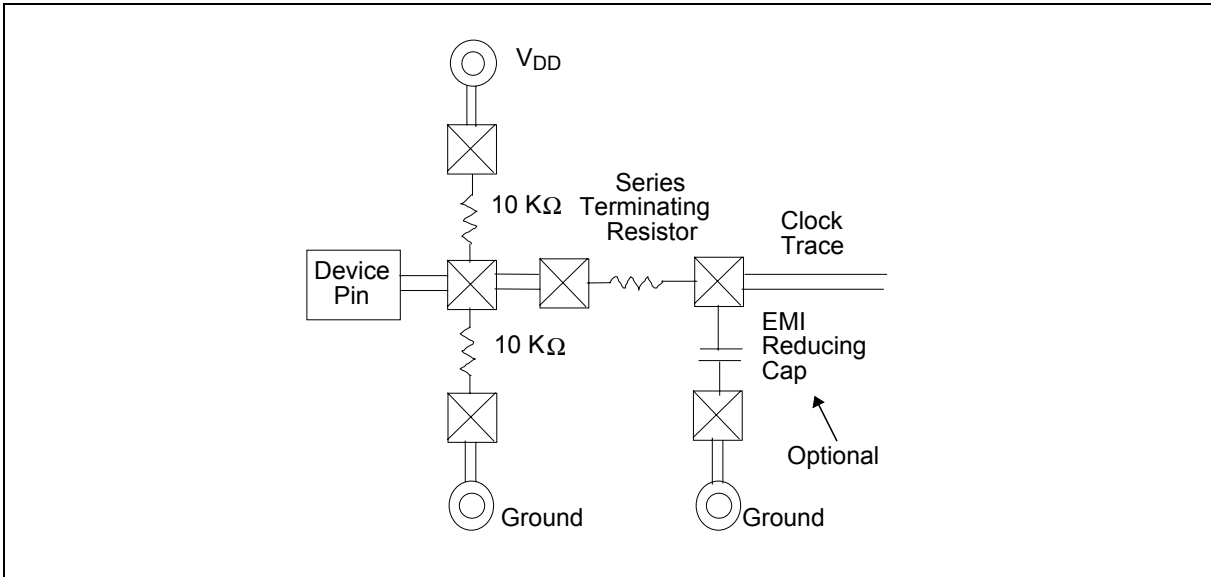



12.0 POWER SUPPLY SUGGESTION

1. A solid ground plane should be placed around the clock device. Ground connections should be tied to this main ground plane as short as possible. No cuts should be made in the ground plane around the device.
2. C21, C22, C31, C36 are decoupling capacitors (0.1 μF surface mount, low ESR, ceramic capacitors.) They should be placed as possible as the VDD pin and the ground via.
3. C1 and C2 are supply filtering capacitors for low frequency power supply noise. A 22 μF (or 10 μF) tantalum capacitor is recommended.
4. Use of Ferrite Bead (FB) are recommended to further reduce the power supply noise.
5. The power supply trace to the VDD pins must be thick enough so that voltage drops across the trace resistance is negligible.

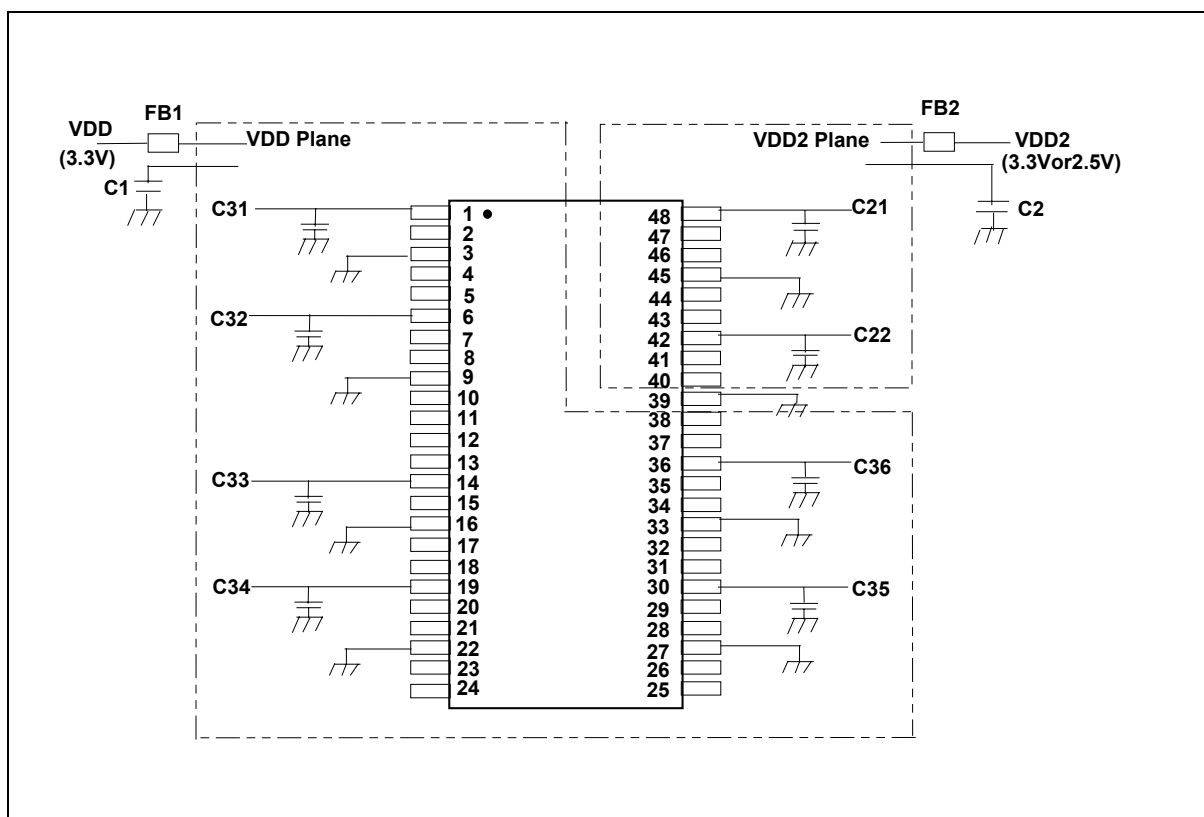

Preliminary W83194R-37/-58



13.0 ORDERING INFORMATION

PART NUMBER	PACKAGE TYPE	PRODUCTION FLOW
W83194R-37/-58	48-pin SSOP	Commercial, 0° C to +70° C

14.0 HOW TO READ THE TOP MARKING

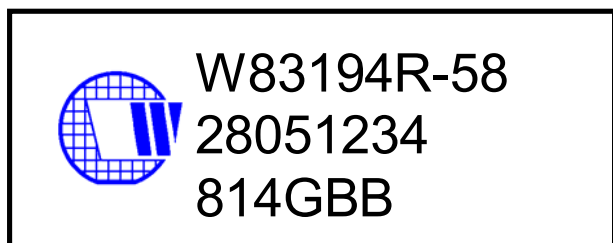
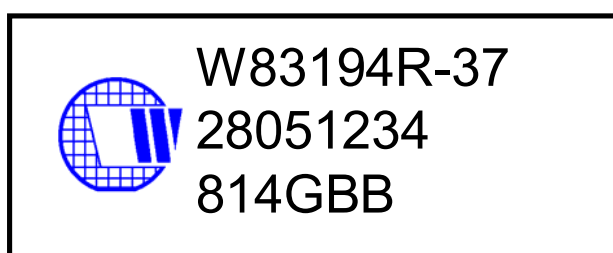

1st line: Winbond logo and the type number: W83194R-37/-58

2nd line: Tracking code 2 8051234

2: wafers manufactured in Winbond FAB 2

8051234: wafer production series lot number

3rd line: Tracking code 814 G B B

814: packages made in '98, week 14

G: assembly house ID; A means ASE, S means SPIL, G means GR

BB: IC revision

All the trade marks of products and companies mentioned in this data sheet belong to their respective owners.

Preliminary W83194R-37/-58



15.0 PACKAGE DRAWING AND DIMENSIONS

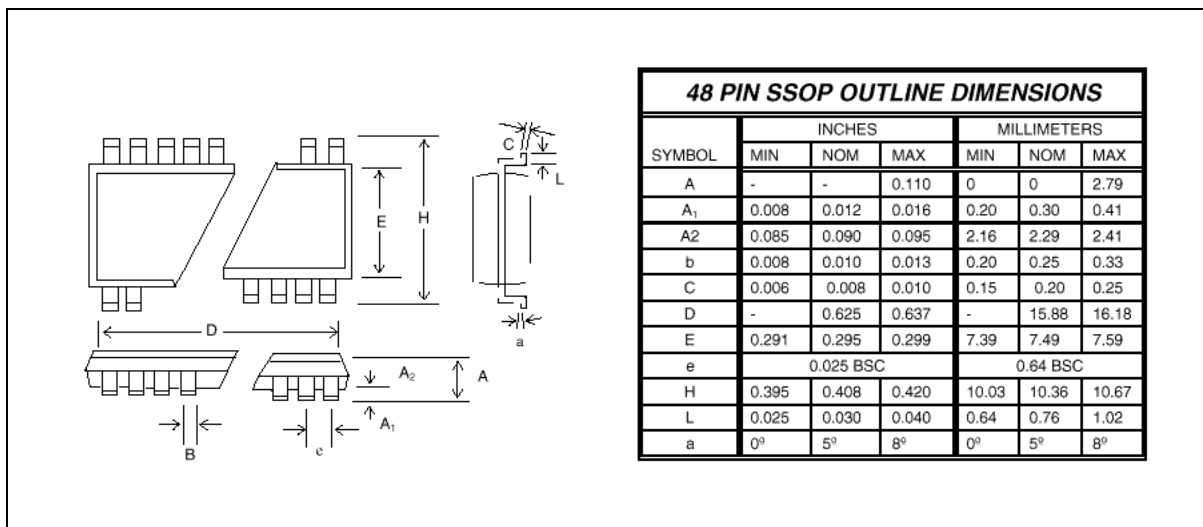

Headquarters

No. 4, Creation Rd. III,
Science-Based Industrial Park,
Hsinchu, Taiwan
TEL: 886-3-5770066
FAX: 886-3-5792646
<http://www.winbond.com.tw/>
Voice & Fax-on-demand: 886-2-27197006

Taipei Office

11F, No. 115, Sec. 3, Min-Sheng East Rd.,
Taipei, Taiwan
TEL: 886-2-27190505
FAX: 886-2-27197502

Winbond Electronics (H.K.) Ltd.
Rm. 803, World Trade Square, Tower II,
123 Hoi Bun Rd., Kwun Tong,
Kowloon, Hong Kong
TEL: 852-27513100
FAX: 852-27552064

Winbond Electronics North America Corp.
Winbond Memory Lab.
Winbond Microelectronics Corp.
Winbond Systems Lab.
2727 N. First Street, San Jose,
CA 95134, U.S.A.
TEL: 408-9436666
FAX: 408-5441798

Note: All data and specifications are subject to change without notice.

Please note that all data and specifications are subject to change without notice. All the trade marks of products and companies mentioned in this data sheet belong to their respective owners.

These products are not designed for use in life support appliances, devices, or systems where malfunction of these products can reasonably be expected to result in personal injury. Winbond customers using or selling these products for use in such applications do so at their own risk and agree to fully indemnify Winbond for any damages resulting from such improper use or sale.

Publication Release Date: April 1999
Revision A1