



Dual N-Channel Enhancement Mode Field Effect Transistor

PRODUCT SUMMARY		
VDSS	ID	RDS(ON) (mΩ) Max
60V	5A	60 @ VGS = 10V 75 @ VGS = 4.5V

FEATURES

- Super high dense cell design for low RDS(ON).
- Rugged and reliable.
- Surface Mount Package.

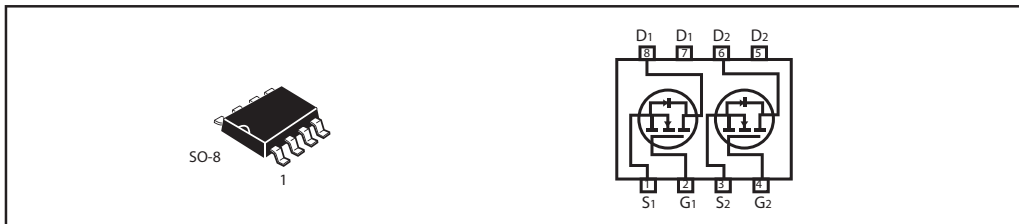

ABSOLUTE MAXIMUM RATINGS (TA=25°C unless otherwise noted)

Parameter	Symbol	Limit	Unit	
Drain-Source Voltage	VDS	60	V	
Gate-Source Voltage	VGS	±20	V	
Drain Current-Continuous ^a @Ta	ID	25°C	5	A
		70°C	4.3	A
-Pulsed ^b	IDM	25	A	
Drain-Source Diode Forward Current ^a	IS	1.7	A	
Maximum Power Dissipation ^a	PD	Ta=25°C	2	W
		Ta=70°C	1.44	
Operating Junction and Storage Temperature Range	TJ, TSTG	-55 to 150	°C	

THERMAL CHARACTERISTICS

Thermal Resistance, Junction-to-Ambient ^a	RθJA	62.5	°C/W
--	------	------	------

STM6960

ELECTRICAL CHARACTERISTICS (TA = 25 °C unless otherwise noted)

Parameter	Symbol	Condition	Min	Typ ^c	Max	Unit
OFF CHARACTERISTICS						
Drain-Source Breakdown Voltage	BV _{DSS}	V _{GS} = 0V, I _D = 250uA	60			V
Zero Gate Voltage Drain Current	I _{DSS}	V _{DS} = 48V, V _{GS} = 0V			1	uA
Gate-Body Leakage	I _{GSS}	V _{GS} = ± 20V, V _{DS} = 0V			±100	nA
ON CHARACTERISTICS^b						
Gate Threshold Voltage	V _{GS(th)}	V _{DS} = V _{GS} , I _D = 250uA	1.0	1.8	3.0	V
Drain-Source On-State Resistance	R _{DS(ON)}	V _{GS} = 10V, I _D = 4.5A		47	60	m ohm
		V _{GS} = 4.5V, I _D = 3A		55	75	m ohm
On-State Drain Current	I _{D(ON)}	V _{DS} = 5V, V _{GS} = 10V	20			A
Forward Transconductance	g _{FS}	V _{DS} = 5V, I _D = 4.5A		12		S
DYNAMIC CHARACTERISTICS^c						
Input Capacitance	C _{ISS}	V _{DS} = 25V, V _{GS} = 0V f = 1.0MHz		700		pF
Output Capacitance	C _{OSS}			80		pF
Reverse Transfer Capacitance	C _{RSS}			50		pF
Gate resistance	R _g	V _{GS} = 0V, V _{DS} = 0V, f = 1.0MHz		5		ohm
SWITCHING CHARACTERISTICS^c						
Turn-On Delay Time	t _{D(ON)}	V _{DD} = 30V I _D = 4.5 A V _{GS} = 10V R _{GEN} = 3 ohm		13		ns
Rise Time	t			10		ns
Turn-Off Delay Time	t _{D(OFF)}			28		ns
Fall Time	t			7		ns
Total Gate Charge	Q _g	V _{DS} = 48V, I _D = 4.5A, V _{GS} = 10V		15		nC
		V _{DS} = 48V, I _D = 4.5A, V _{GS} = 4.5V		7.5		nC
Gate-Source Charge	Q _{gs}	V _{DS} = 48V, I _D = 4.5 A V _{GS} = 10V		1.6		nC
Gate-Drain Charge	Q _{gd}			4.3		nC

STM6960

ELECTRICAL CHARACTERISTICS ($T_A=25^{\circ}\text{C}$ unless otherwise noted)

Parameter	Symbol	Condition	Min	Typ ^c	Max	Unit
DRAIN-SOURCE DIODE CHARACTERISTICS ^b						
Diode Forward Voltage	V_{SD}	$V_{GS} = 0V, I_S = 1.7A$		0.8	1.2	V

Notes

- a. Surface Mounted on FR4 Board, $t \leq 10\text{sec}$.
- b. Pulse Test: Pulse Width $\leq 300\mu\text{s}$, Duty Cycle $\leq 2\%$.
- c. Guaranteed by design, not subject to production testing.

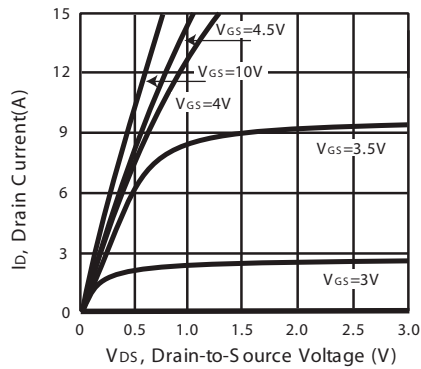

Figure 1. Output Characteristics

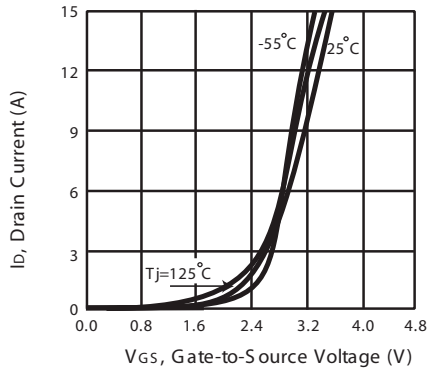

Figure 2. Transfer Characteristics

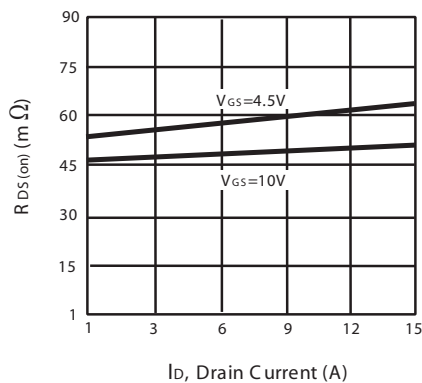

Figure 3. On-Resistance vs. Drain Current and Gate Voltage

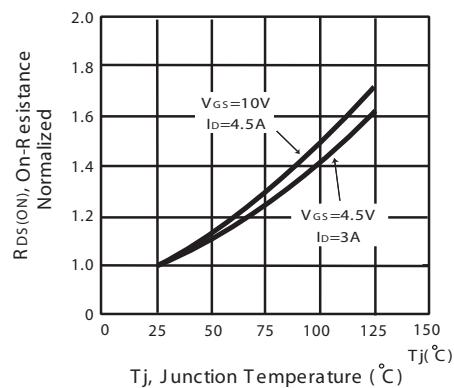

Figure 4. On-Resistance Variation with Drain Current and Temperature

STM6960

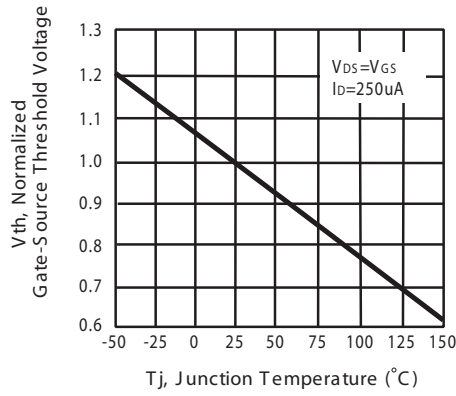

Figure 5. Gate Threshold Variation with Temperature

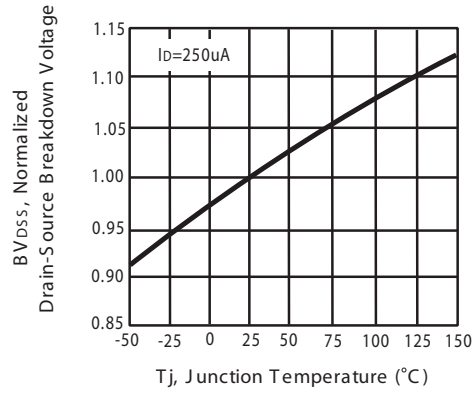

Figure 6. Breakdown Voltage Variation with Temperature

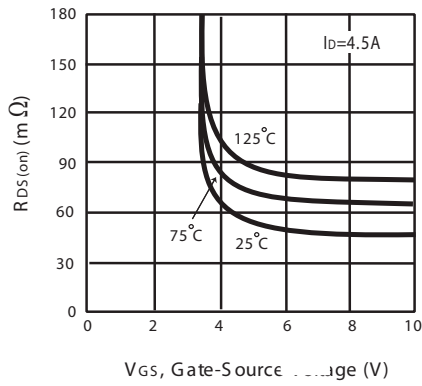

Figure 7. On-Resistance vs. Gate-Source Voltage

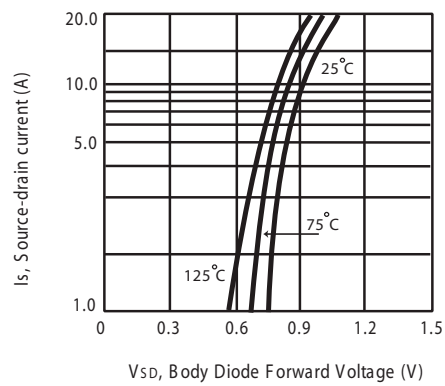

Figure 8. Body Diode Forward Voltage Variation with Source Current

STM6960

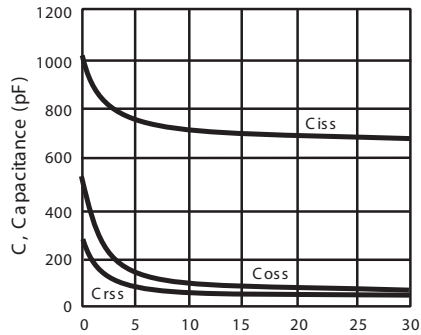

Figure 9. Capacitance

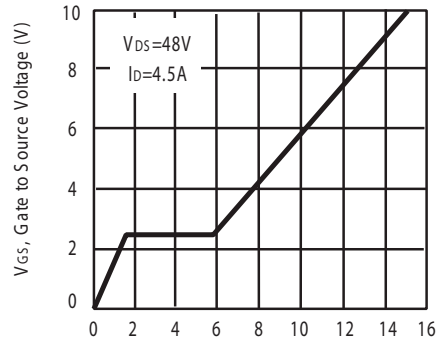

Figure 10. Gate Charge

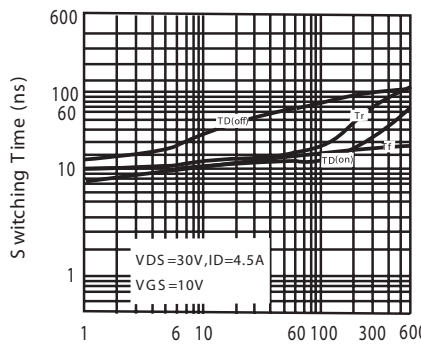

Figure 11. switching characteristics

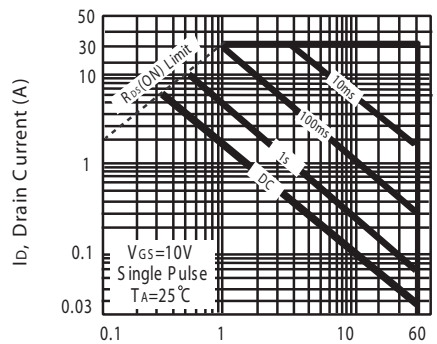
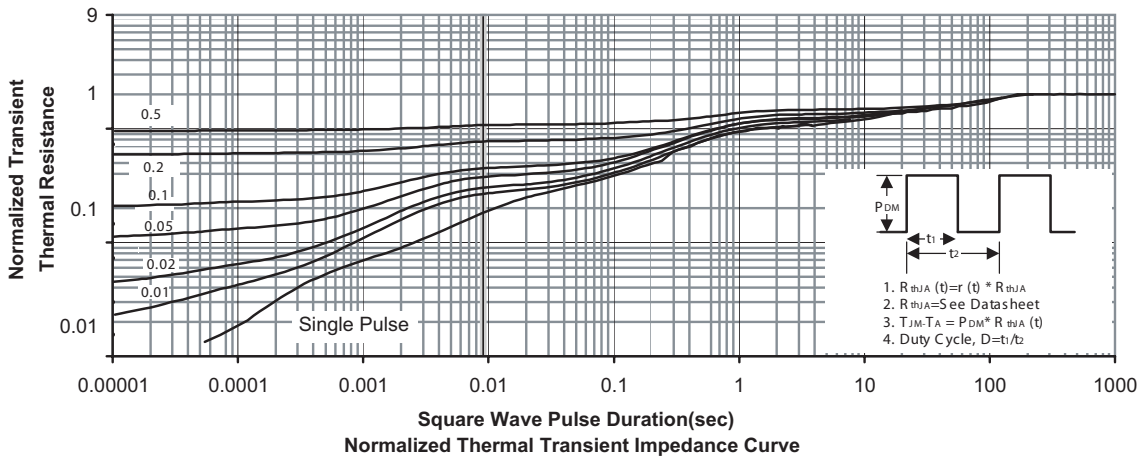

Figure 12. Maximum Safe Operating Area



STM6960

PACKAGE OUTLINE DIMENSIONS

SO-8

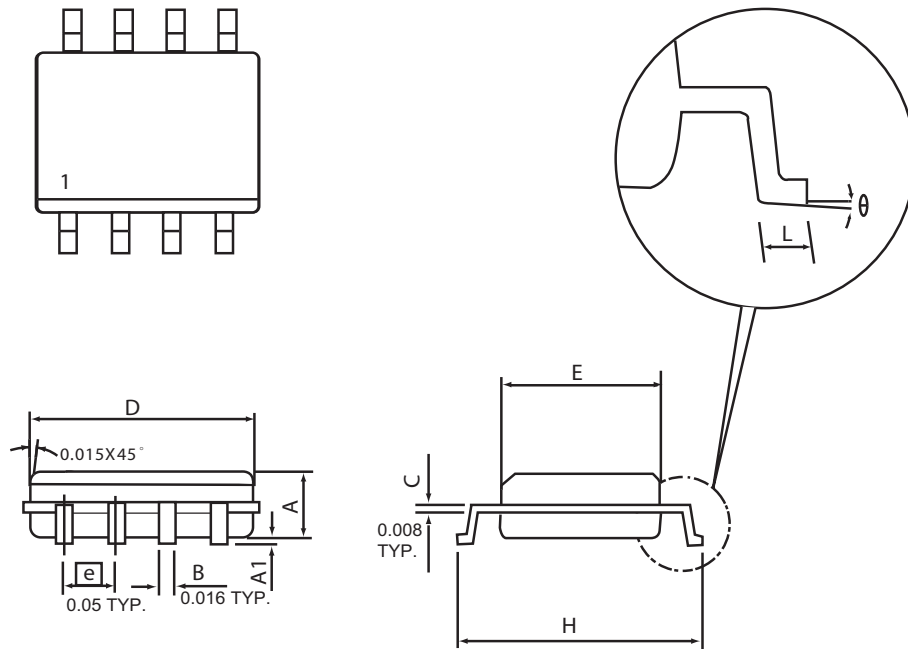

SYMBOLS	MILLIMETERS		INCHES	
	MIN	MAX	MIN	MAX
A	1.35	1.75	0.053	0.069
A1	0.10	0.25	0.004	0.010
D	4.80	4.98	0.189	0.196
E	3.81	3.99	0.150	0.157
H	5.79	6.20	0.228	0.244
L	0.41	1.27	0.016	0.050
θ	0°	8°	0°	8°

STM6960

SO-8 Tape and Reel Data

SO-8 Carrier Tape

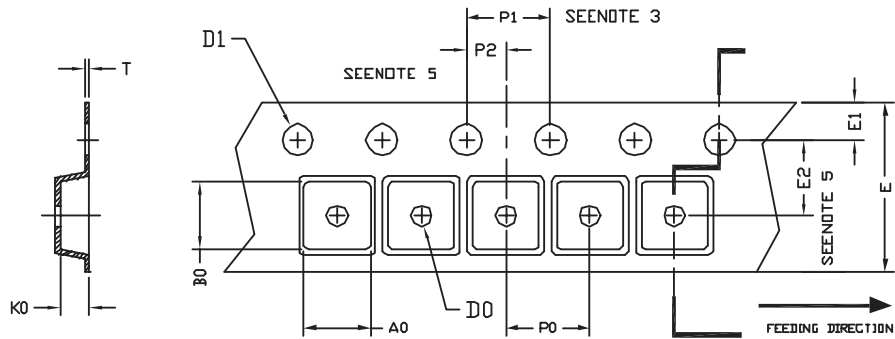

unit:mm

PACKAGE	A0	B0	K0	D0	D1	E	E1	E2	P0	P1	P2	T
SOP 8N 150mil	6.40	5.20	2.10	ϕ 1.5 (MIN)	ϕ 1.5 + 0.1 - 0.0	12.0 \pm 0.3	1.75	5.5 \pm 0.05	8.0	4.0	2.0 \pm 0.05	0.3 \pm 0.05

SO-8 Reel

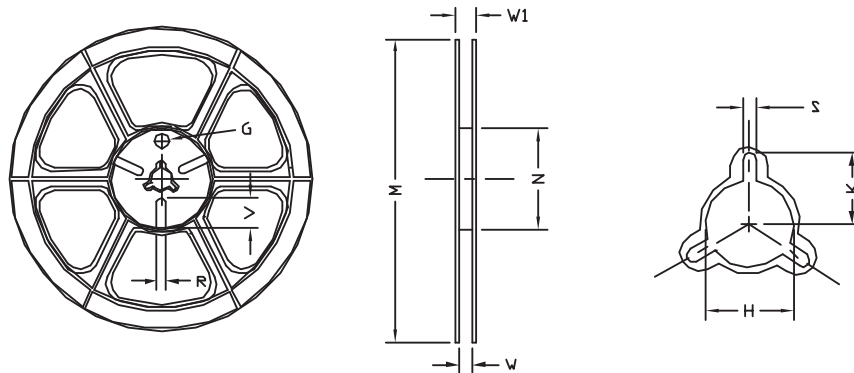

UNIT:mm

TAPE SIZE	REEL SIZE	M	N	W	W1	H	K	S	G	R	V
12 mm	ϕ 330	330 \pm 1	62 \pm 1.5	12.4 + 0.2	16.8 - 0.4	ϕ 12.75 + 0.15	---	2.0 \pm 0.15	---	---	---