

### ORDERING INFORMATION

Device	Temperature Range	Package
MC1550F	-55°C to +125°C	Ceramic Flat
MC1550G	-55°C to +125°C	Metal Can

### RF - IF AMPLIFIER

... a versatile, common-emitter, common-base cascode circuit for use in communications applications. See Application Note AN-215A for additional information.

- Constant Input Impedance over entire AGC range
- Extremely Low  $\gamma_{12}$  - 4.3  $\mu$ mhos at 60 MHz
- High Power Gain - 30 dB @ 60 MHz (0.5 MHz BW)
- Good Noise Figure - 5 dB @ 60 MHz

### MAXIMUM RATINGS ( $T_A = +25^\circ\text{C}$ unless otherwise noted)

Rating	Symbol	Value	Unit
Power Supply Voltage, Pin 9	$V_{CC}$	20	Vdc
AGC Supply Voltage	$V_{AGC}$	20	Vdc
Input Differential Voltage, Pin 1 to Pin 4 ( $R_S = 500$ ohms)	$V_{ID}$	$\pm 5.0$	V(rms)
Power Dissipation (Package Limitation)	$P_D$	Metal Can	680
		Derate above $T_A = +25^\circ\text{C}$	4.6
		Flat Package	500
Derate above $T_A = +25^\circ\text{C}$	3.3		
Operating Ambient Temperature Range	$T_A$	-55 to +125	$^\circ\text{C}$
Storage Temperature Range	$T_{stg}$	-65 to +150	$^\circ\text{C}$

### CIRCUIT SCHEMATIC

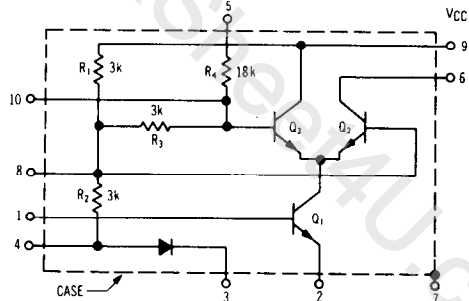

### CIRCUIT DESCRIPTION

The MC1550 is built with monolithic fabrication techniques utilizing diffused resistors and small-geometry transistors. Excellent AGC performance is obtained by shunting the signal through the AGC transistor  $Q_2$ , maintaining the operating point of the input transistor  $Q_1$ . This keeps the input impedance constant over the entire AGC range.

The amplifier is intended to be used in a common-emitter, common-base configuration ( $Q_1$  and  $Q_2$ ) with  $Q_1$  acting as an AGC transistor. The input signal is applied between pins 1 and 4, where pin 4 is ac-coupled to ground. DC source resistance between pins 1 and 4 should be small (less than 100 ohms). Pins 2 and 3 should be connected together and grounded. Pins 8 and 10 should be bypassed to ground. The positive supply voltage is applied at pin 9 and at higher frequencies, pin 9 should also be bypassed to ground. The output is taken between pins 6 and 9. The substrate is connected to pin 7 and should be grounded. AGC voltage is applied to pin 5.

## MC1550G

### RF - IF AMPLIFIER SILICON MONOLITHIC INTEGRATED CIRCUIT



G SUFFIX  
METAL PACKAGE  
CASE 603B

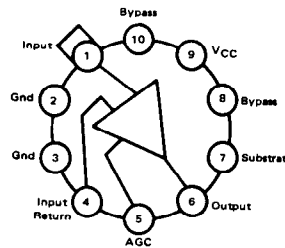

## MC1550G

### ELECTRICAL CHARACTERIS

Characteristic
DC CHARACTERISTICS
Output Voltage
Test Voltage
Supply Drain Current
AGC Supply Drain Current
SMALL-SIGNAL CHARACTERISTIC
Small-Signal Voltage Gain
Bandwidth
Transducer Power Gain

FIGURE 1 - DC CHARACT

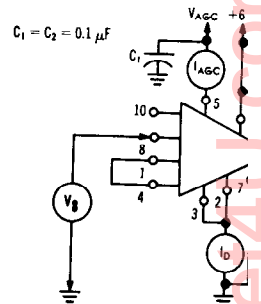
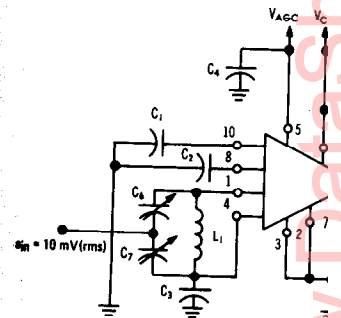

FIGURE 3 - POWER GAIN T



# MC1550G

RF - IF AMPLIFIER  
SILICON MONOLITHIC  
INTEGRATED CIRCUIT



G SUFFIX  
METAL PACKAGE  
CASE 6038

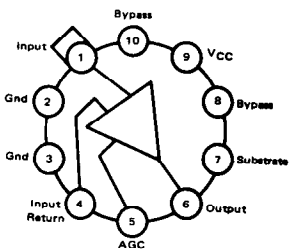

MC1550G

## ELECTRICAL CHARACTERISTICS ( $V^+ = +6 \text{ Vdc}$ , $T_A = +25^\circ\text{C}$ )

Characteristic	Conditions	Figure	Symbol	Min	Typ	Max	Unit
<b>DC CHARACTERISTICS</b>							
Output Voltage	$V_{AGC} = 0 \text{ Vdc}$ $V_{AGC} = +6 \text{ Vdc}$	1	$V_O$	3.80 5.90	-	4.65 6.00	Vdc
Test Voltage	$V_{AGC} = 0 \text{ Vdc}$ $V_{AGC} = +6 \text{ Vdc}$	1	$V_B$	2.85 3.25	-	3.40 3.80	Vdc
Supply Drain Current	$V_{AGC} = 0 \text{ Vdc}$ $V_{AGC} = +6 \text{ Vdc}$	1	$I_D$	- -	-	2.2 2.5	mAdc
AGC Supply Drain Current	$V_{AGC} = 0 \text{ Vdc}$ $V_{AGC} = +6 \text{ Vdc}$	1	$I_{AGC}$	- -	-	-0.2 0.18	mAdc
<b>SMALL-SIGNAL CHARACTERISTICS</b>							
Small-Signal Voltage Gain	$f = 500 \text{ kHz}$	2	$A_V$	22	-	29	dB
Bandwidth	-3.0 dB	2	BW	22	-	-	MHz
Transducer Power Gain	$f = 60 \text{ MHz}$ , BW = 6 MHz $f = 100 \text{ MHz}$ , BW = 6 MHz	3	$A_P$	-	25 21	-	dB

## TYPICAL CHARACTERISTICS

( $V_{CC} = 6.0 \text{ Vdc}$ ,  $T_A = +25^\circ\text{C}$  unless otherwise noted.)

FIGURE 1 - DC CHARACTERISTICS TEST CIRCUIT

FIGURE 2 - VOLTAGE GAIN AND BANDWIDTH TEST CIRCUIT

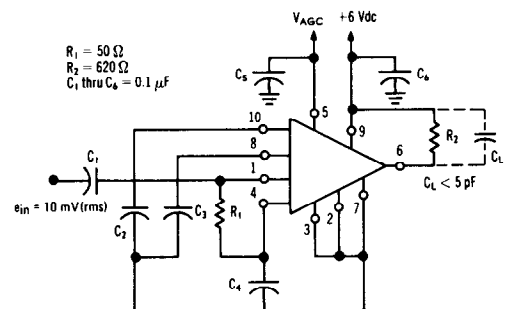
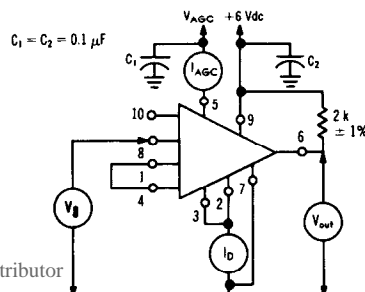

TYPICAL CHARACTERISTICS (continued)

FIGURE 5 - INPUT RESISTANCE AND CAPACITANCE versus FREQUENCY

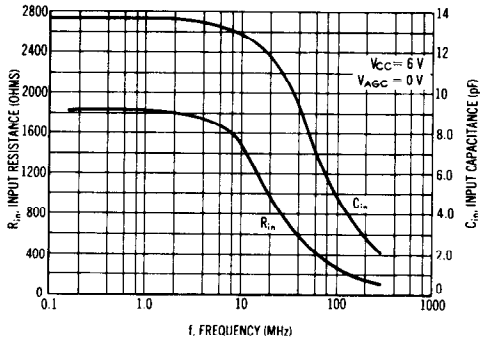

FIGURE 6 - INPUT RESISTANCE AND CAPACITANCE versus AGC VOLTAGE

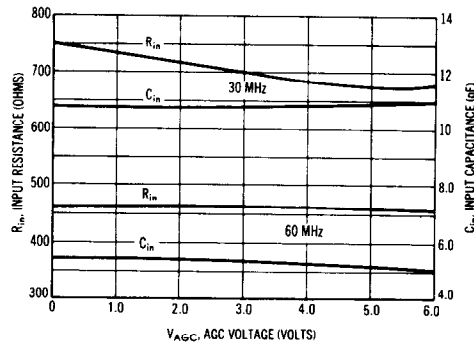

FIGURE 7 - OUTPUT RESISTANCE AND CAPACITANCE versus FREQUENCY

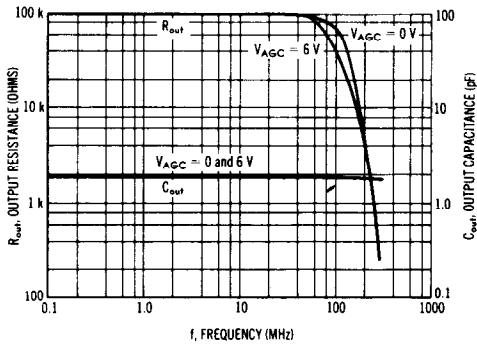

FIGURE 8 - OUTPUT RESISTANCE AND CAPACITANCE versus AGC VOLTAGE

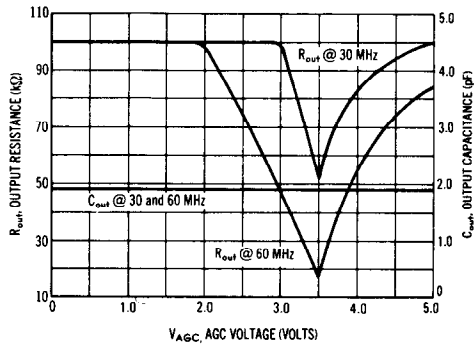

FIGURE 9 - MAXIMUM TRANSDUCER POWER GAIN versus FREQUENCY

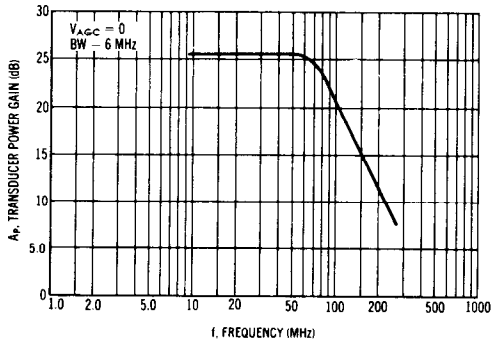

FIGURE 10 - TRANSDUCER POWER GAIN versus TEMPERATURE

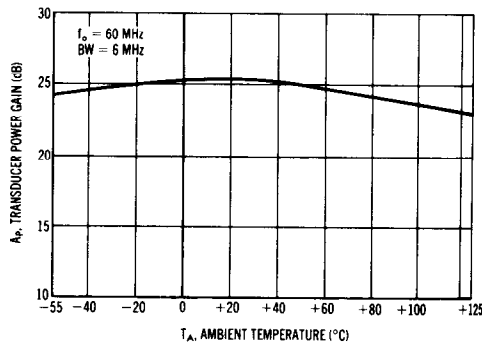

FIGURE 11

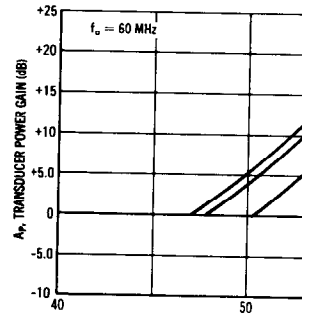

FIGURE 12 - NOISE FIGURE A RESISTANCE versus F

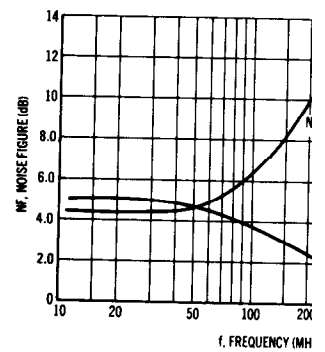
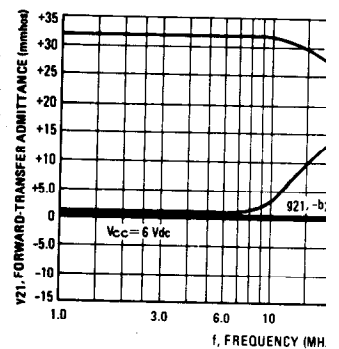

FIGURE 14 - y21, FORWARD-TRAN versus FREQUENCY



# MC1550G

## TYPICAL CHARACTERISTICS (continued)

**INPUT RESISTANCE AND  
C<sub>in</sub> versus AGC VOLTAGE**

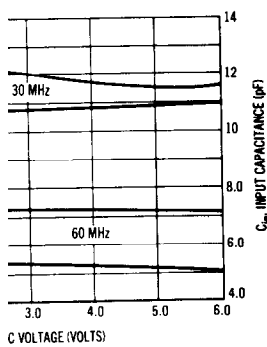

**OUTPUT RESISTANCE AND  
C<sub>out</sub> versus AGC VOLTAGE**

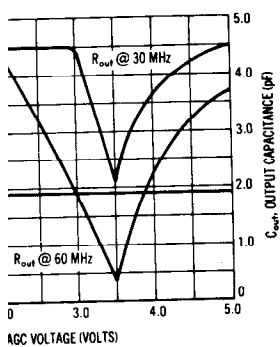

**FIGURE 11 – TRANSDUCER POWER BANDWIDTH versus AGC VOLTAGE**

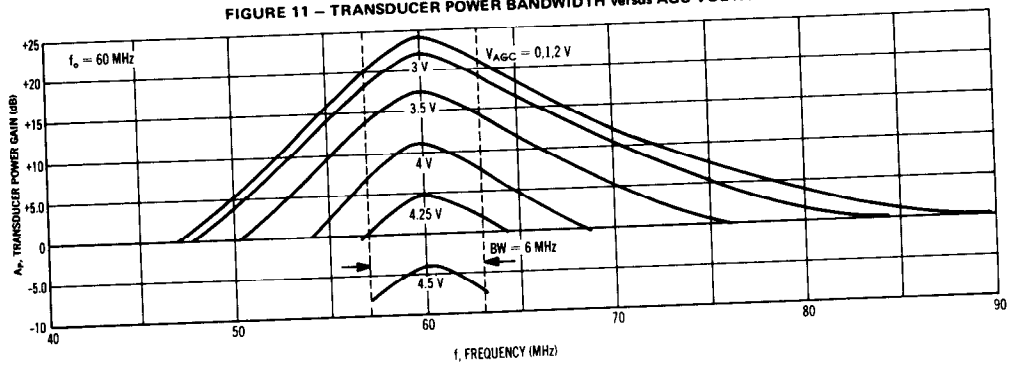

**FIGURE 12 – NOISE FIGURE AND OPTIMUM SOURCE  
RESISTANCE versus FREQUENCY**

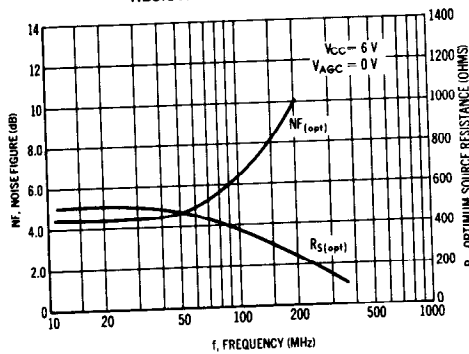

**FIGURE 13 – NOISE FIGURE versus SOURCE RESISTANCE**

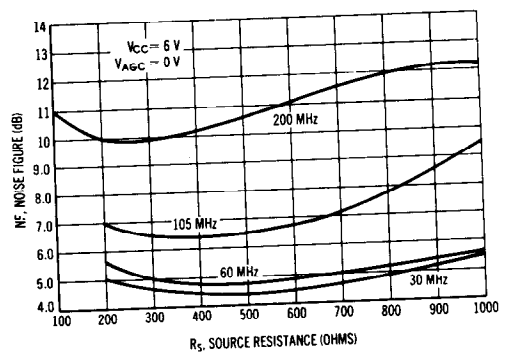

**FIGURE 15 – Y<sub>21</sub> FORWARD TRANSFER ADMITTANCE  
versus AGC VOLTAGE**

TYPICAL CHARACTERISTICS

( $V_{CC} = 6.0\text{Vdc}$ ,  $T_A = +25^\circ\text{C}$  unless otherwise noted.)

FIGURE 16 -  $y_{12}$ , REVERSE TRANSFER-ADMITTANCE versus FREQUENCY

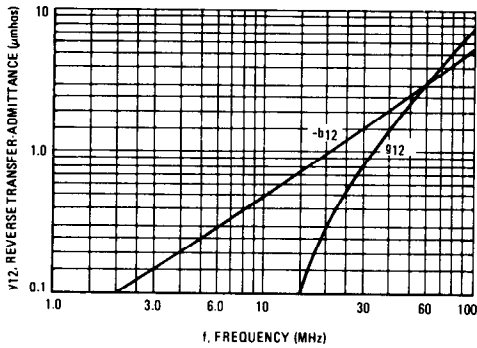

FIGURE 17 -  $y_{11}$ , INPUT-ADMITTANCE versus FREQUENCY

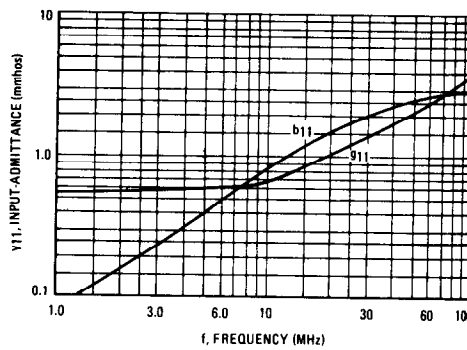

FIGURE 20 -  $s_{11}$ , INPL REFLECTION COEFFICIENT versus

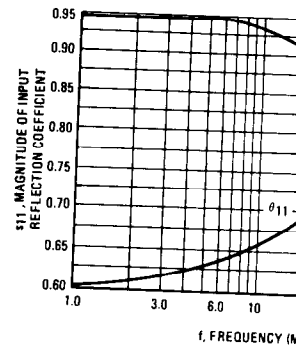

FIGURE 19 -  $s_{11}$  AND  $s_{22}$ , INPUT AND OUTPUT REFLECTION COEFFICIENT

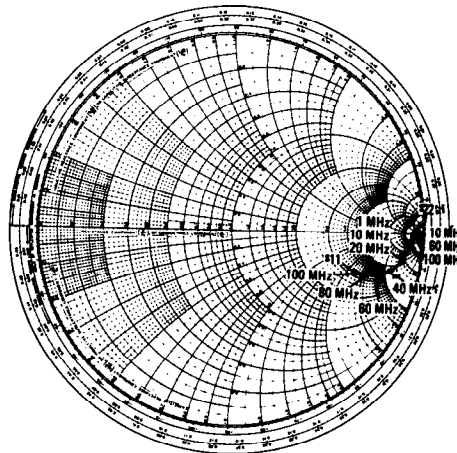
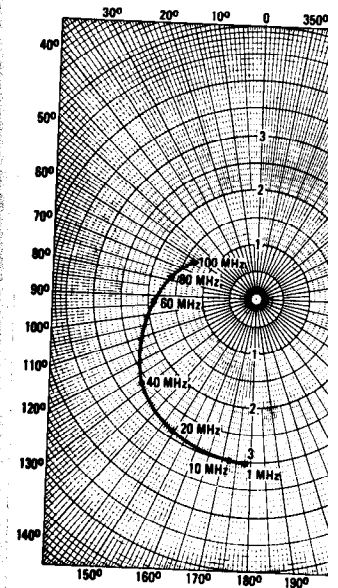

FIGURE 22 -  $s_{21}$ , FORWARD COEFFICIENT (



The  $y_{12}$  shown in Figure 16 illustrates the extremely low feedback of the MC1550 with no contribution from the external mounting circuitry. However, in many cases the external circuitry may contribute as much or more to the total feedback than does the MC1550.

To perform more accurate design calculations of gain, stability, and input - output impedances it is recommended that the designer first determine the total feedback of device plus circuitry.

This can be done in one of two ways:

- (1) Measure the total  $y_{12}$  or  $s_{12}$  of the MC1550 installed in its mounting circuitry, or
- (2) Measure the  $y_{12}$  of the circuitry alone (without the MC1550 installed) and add the circuit  $y_{12}$  to the  $y_{12}$  for the MC1550 given in Figure 16.

FIGURE 18 -  $y_{22}$ , OUTPUT-ADMITTANCE versus FREQUENCY

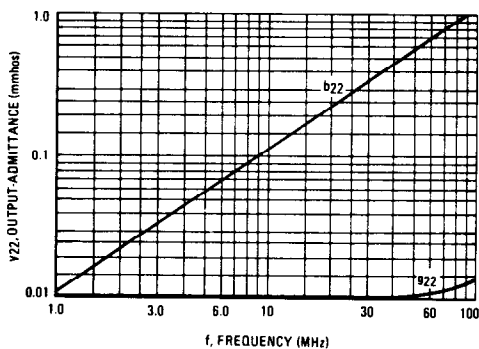

MC1550G

INPUT ADMITTANCE versus FREQUENCY

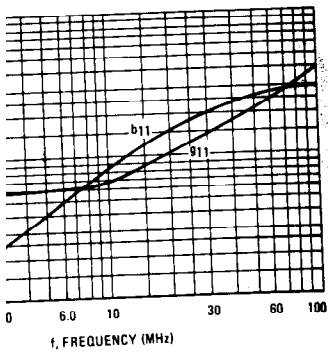

9 -  $s_{11}$  AND  $s_{22}$ , INPUT AND OUTPUT REFLECTION COEFFICIENT

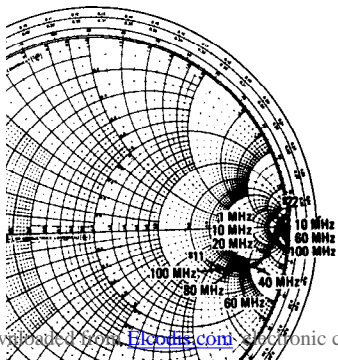

TYPICAL CHARACTERISTICS (continued)  
 ( $V_{CC} = 6.0 \text{ Vdc}$ ,  $T_A = +25^\circ\text{C}$  unless otherwise noted.)

FIGURE 20 -  $s_{11}$ , INPUT REFLECTION COEFFICIENT versus FREQUENCY

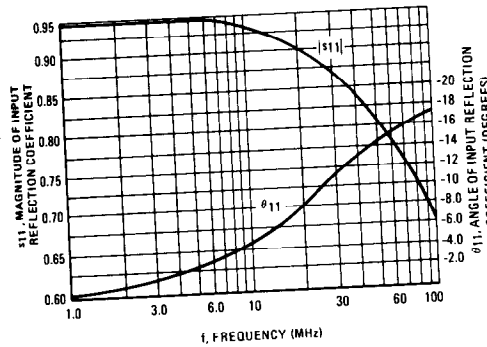

FIGURE 22 -  $s_{21}$ , FORWARD TRANSMISSION COEFFICIENT (GAIN)

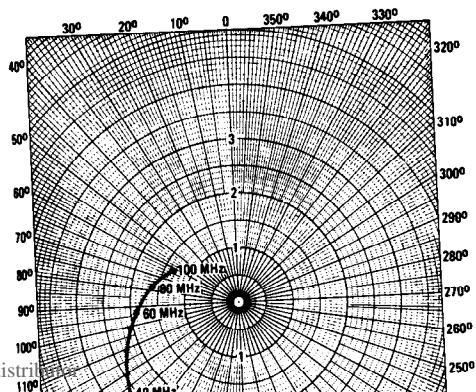

FIGURE 21 -  $s_{22}$ , OUTPUT REFLECTION COEFFICIENT versus FREQUENCY

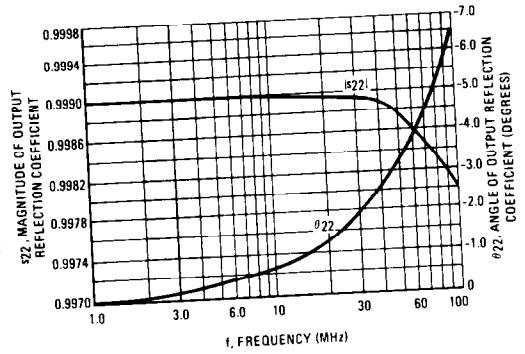

FIGURE 23 -  $s_{12}$ , REVERSE TRANSMISSION COEFFICIENT (FEEDBACK)

