

**300mA FIXED OUTPUT VOLTAGE LDO REGULATOR****AP2115****General Description**

The AP2115 is positive voltage regulator IC designed by CMOS process. The AP2115 has features of low dropout voltage, high output voltage accuracy and low current consumption. It consists of a voltage reference, an error amplifier, a resistor network for setting output voltage, a current limit circuit for current protection, a circuit for over temperature protection and a chip enable circuit. Thus, the AP2115 is suitable for various power sources for portable application.

The AP2115 is available in standard SOT-23-5 package.

Features

- High Ripple Rejection: 70dB at f=1KHz
- Ultra Low Dropout Voltage: 0.3V Typical at $I_{OUT}=300mA$
- Low Operation Current: 80 μA Typical
- High Line Regulation: 4mV Typical
- High Load Regulation: 12mV Typical at $I_{OUT}=300mA$
- Low Temperature-drift Coefficient of Output Voltage
- High Output Voltage Accuracy: $\pm 2\%$
- Excellent Line Transient Response and Load Transient Response
- Output Voltage: 1.8V, 2.5V, 2.8V, 3.0V, 3.3V
- Low ESR Capacitor Compatible
- Wide Temperature Range: -40°C to 125°C
- Current and Thermal Protection

Application

- Mobile Phones, Cordless Phones
- Portable Games
- Cameras
- Portable AV Equipment
- Battery Powered Equipment

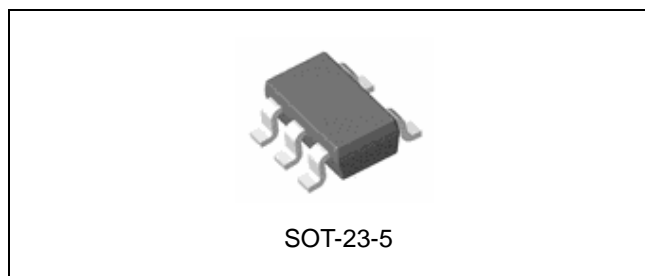

Figure 1. Package Type of AP2115

**300mA FIXED OUTPUT VOLTAGE LDO REGULATOR****AP2115****Pin Configuration**

Figure 2. Pin Configuration of AP2115 (Top View)

Pin Description

Pin Number	Pin Name	Function
1	V_{OUT}	Voltage regulator output pin
2	GND	Ground pin
3	V_{IN}	Input voltage pin
4	$\overline{CE/CE}$	Active high/low enable input pin (active high for AP2115B)
5	NC	No connection

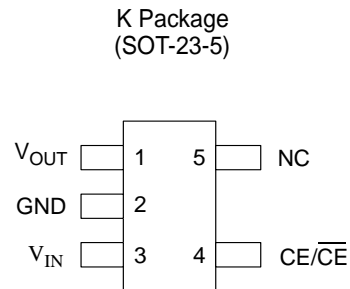

300mA FIXED OUTPUT VOLTAGE LDO REGULATOR

AP2115

Functional Block Diagram

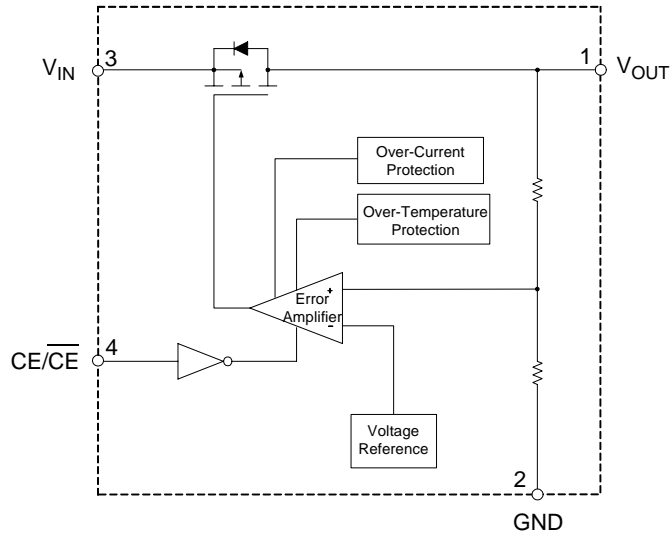

Active High Version

Figure 3. Functional Block Diagram of AP2115

Ordering Information

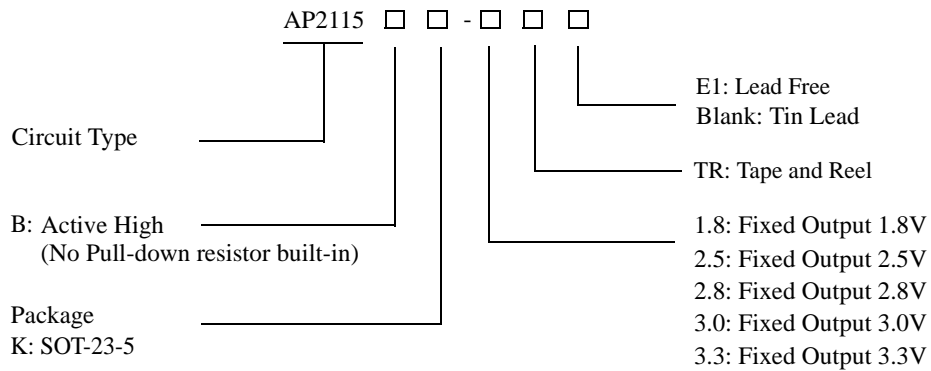

**300mA FIXED OUTPUT VOLTAGE LDO REGULATOR****AP2115****Ordering Information (Continued)**

Package	Temperature Range	Part Number		Marking ID		Packing Type
		Tin Lead	Lead Free	Tin Lead	Lead Free	
SOT-23-5	-40 to 125°C	AP2115BK-1.8TR	AP2115BK-1.8TRE1	K7B	E7B	Tape & Reel
		AP2115BK-2.5TR	AP2115BK-2.5TRE1	K7D	E7D	Tape & Reel
		AP2115BK-2.8TR	AP2115BK-2.8TRE1	K7F	E7F	Tape & Reel
		AP2115BK-3.0TR	AP2115BK-3.0TRE1	K7H	E7H	Tape & Reel
		AP2115BK-3.3TR	AP2115BK-3.3TRE1	K7J	E7J	Tape & Reel

BCD Semiconductor's Pb-free products, as designated with "E1" suffix in the part number, are RoHS compliant.

Absolute Maximum Ratings (Note 1)

Parameter	Symbol	Value	Unit
Input Voltage (Note 2)	V_{IN}	-0.3 to 8	V
Input Voltage (CE/ \overline{CE} Pin)	V_{SHDN}	-0.3 to $V_{IN}+0.3$	V
Output Voltage	V_{OUT}	-0.3 to $V_{IN}+0.3$	V
Output Current	I_{OUT}	500	mA
Power Dissipation	P_D	250	mW
Storage Temperature Range	T_{STG}	-65 to 150	°C
Lead Temperature (Soldering, 10sec)	T_{LEAD}	300	°C
ESD (Machine Model)	ESD	200	V

Note 1: Stresses greater than those listed under "Absolute Maximum Ratings" may cause permanent damage to the device. These are stress ratings only, and functional operation of the device at these or any other conditions beyond those indicated under "Recommended Operating Conditions" is not implied. Exposure to "Absolute Maximum Ratings" for extended periods may affect device reliability.

Note 2: All voltage values are with respect to network ground terminal.

Recommended Operating Conditions

Parameter	Symbol	Min	Max	Unit
Input Voltage (Note 3)	V_{IN}	2.2	6.5	V
Operating Junction Temperature Range	T_J	-40	125	°C

Note 3: To calculate the minimum input voltage for maximum output current, the following formula is recommended:

$$V_{IN(\text{Min})} = V_{OUT(\text{Max})} + V_{DROPO(\text{Max load})}$$



300mA FIXED OUTPUT VOLTAGE LDO REGULATOR

AP2115

Electrical Characteristics

AP2115-1.8V Electrical Characteristics

$V_{IN}=V_{OUT}+1V$, $T_A=25^{\circ}C$, $C_{IN}=1\mu F$, $C_L=1\mu F$, unless otherwise specified.

Parameter	Symbol	Conditions	Min	Typ	Max	Unit
Output Voltage	V_{OUT}	$1mA \leq I_{OUT} \leq 30mA$	1.764	1.8	1.836	V
Output Current	I_{OUT}		300			mA
Current Limit				500		mA
Quiescent Current				80	150	μA
Ground Pin Current	I_{GND}	$I_{OUT}=300mA$		90	150	μA
Dropout Voltage (Note 4)	V_{DROP}	$I_{OUT}=1mA$		400	600	mV
		$I_{OUT}=50mA$		400	600	
		$I_{OUT}=200mA$		400	600	
		$I_{OUT}=300mA$		600	900	
Load Regulation	V_{RLOAD}	$1mA \leq I_{OUT} \leq 300mA$		7.2	18	mV
Line Regulation	V_{RLINE}	$V_{OUT}+0.5V \leq V_{IN} \leq 6V$ $I_{OUT}=30mA$		4	15	mV
CE/ \overline{CE} Input High Threshold	V_{IH}		1.5			V
CE/ \overline{CE} Input Low Threshold	V_{IL}				0.4	V
CE/ \overline{CE} Bias Current	I_{SD}				100	nA
Shutdown Supply Current	I_{GSD}	$V_{OUT}=0V$		0.1	1	μA
Thermal Shutdown Temperature	T_{SD}			165		$^{\circ}C$
Power Supply Ripple Rejection	PSRR	Ripple 0.5V _{P-P} $f=1kHz$, $I_{OUT}=30mA$		70		dB
Output Voltage Temperature Coefficient	$\Delta V_{OUT}/\Delta T$	$I_{OUT}=30mA$ $-40^{\circ}C \leq T_J \leq 125^{\circ}C$		180		$\mu V/^{\circ}C$
Short Current Limit	I_{LIMIT}	$V_{OUT}=0V$		450		mA
Turn-on Time (Note 5)	T_{ON}			60		μs
RMS Output Noise	V_{NOISE}	$T_A=25^{\circ}C$ $10Hz \leq f \leq 100kHz$		200		μV_{rms}

Note 4: Dropout voltage is defined as the input-to-output differential when the output voltage drops to 98% of its nominal value which is measured at $V_{OUT}+1V$ applied to V_{IN} . The 1.8V version dropout voltage is limited by the input voltage range.

Note 5: Turn-on time is time measured between the enable input just exceeding V_{IH} and the output voltage just reaching 95% of its nominal value.



300mA FIXED OUTPUT VOLTAGE LDO REGULATOR AP2115

Electrical Characteristics (Continued)

AP2115-2.5V Electrical Characteristics

$V_{IN}=V_{OUT}+1V$, $T_A=25^{\circ}C$, $C_{IN}=1\mu F$, $C_L=1\mu F$, unless otherwise specified.

Parameter	Symbol	Conditions	Min	Typ	Max	Unit
Output Voltage	V_{OUT}	$1mA \leq I_{OUT} \leq 30mA$	2.45	2.5	2.55	V
Output Current	I_{OUT}		300			mA
Current Limit				500		mA
Quiescent Current				80	150	μA
Ground Pin Current	I_{GND}	$I_{OUT}=300mA$		90	150	μA
Dropout Voltage (Note 4)	V_{DROP}	$I_{OUT}=1mA$		1	5	mV
		$I_{OUT}=50mA$		50	75	
		$I_{OUT}=200mA$		200	300	
		$I_{OUT}=300mA$		300	450	
Load Regulation	V_{RLOAD}	$1mA \leq I_{OUT} \leq 300mA$		10	25	mV
Line Regulation	V_{RLINE}	$V_{OUT}+0.5V \leq V_{IN} \leq 6V$ $I_{OUT}=30mA$		4	15	mV
CE/ \overline{CE} Input High Threshold	V_{IH}		1.5			V
CE/ \overline{CE} Input Low Threshold	V_{IL}				0.4	V
CE/ \overline{CE} Bias Current	I_{SD}				100	nA
Shutdown Supply Current	I_{GSD}	$V_{OUT}=0V$		0.1	1	μA
Thermal Shutdown Temperature	T_{SD}			165		$^{\circ}C$
Power Supply Ripple Rejection	PSRR	Ripple 0.5V _{P-P} $f=1kHz$, $I_{OUT}=30mA$		70		dB
Output Voltage Temperature Coefficient	$\Delta V_{OUT}/\Delta T$	$I_{OUT}=30mA$ $-40^{\circ}C \leq T_j \leq 125^{\circ}C$		250		$\mu V/^{\circ}C$
Short Current Limit	I_{LIMIT}	$V_{OUT}=0V$		450		mA
Turn-on Time (Note 5)	T_{ON}			60		μs
RMS Output Noise	V_{NOISE}	$T_A=25^{\circ}C$ $10Hz \leq f \leq 100kHz$		200		μV_{rms}

Note 4: Dropout voltage is defined as the input-to-output differential when the output voltage drops to 98% of its nominal value which is measured at $V_{OUT}+1V$ applied to V_{IN} .

Note 5: Turn-on time is time measured between the enable input just exceeding V_{IH} and the output voltage just reaching 95% of its nominal value.



300mA FIXED OUTPUT VOLTAGE LDO REGULATOR AP2115

Electrical Characteristics (Continued)

AP2115-2.8V Electrical Characteristics

$V_{IN}=V_{OUT}+1V$, $T_A=25^{\circ}C$, $C_{IN}=1\mu F$, $C_L=1\mu F$, unless otherwise specified.

Parameter	Symbol	Conditions	Min	Typ	Max	Unit
Output Voltage	V_{OUT}	$1mA \leq I_{OUT} \leq 30mA$	2.744	2.8	2.856	V
Output Current	I_{OUT}		300			mA
Current Limit				500		mA
Quiescent Current				80	150	μA
Ground Pin Current	I_{GND}	$I_{OUT}=300mA$		90	150	μA
Dropout Voltage (Note 4)	V_{DROP}	$I_{OUT}=1mA$		1	5	mV
		$I_{OUT}=50mA$		50	75	
		$I_{OUT}=200mA$		200	300	
		$I_{OUT}=300mA$		300	450	
Load Regulation	V_{RLOAD}	$1mA \leq I_{OUT} \leq 300mA$		11.2	28	mV
Line Regulation	V_{RLINE}	$V_{OUT}+0.5V \leq V_{IN} \leq 6V$ $I_{OUT}=30mA$		4	15	mV
CE/ \overline{CE} Input High Threshold	V_{IH}		1.5			V
CE/ \overline{CE} Input Low Threshold	V_{IL}				0.4	V
CE/ \overline{CE} Bias Current	I_{SD}				100	nA
Shutdown Supply Current	I_{GSD}	$V_{OUT}=0V$		0.1	1	μA
Thermal Shutdown Temperature	T_{SD}			165		$^{\circ}C$
Power Supply Ripple Rejection	PSRR	Ripple 0.5V _{P-P} $f=1kHz$, $I_{OUT}=30mA$		70		dB
Output Voltage Temperature Coefficient	$\Delta V_{OUT}/\Delta T$	$I_{OUT}=30mA$ $-40^{\circ}C \leq T_j \leq 125^{\circ}C$		280		$\mu V/^{\circ}C$
Short Current Limit	I_{LIMIT}	$V_{OUT}=0V$		450		mA
Turn-on Time (Note 5)	T_{ON}			60		μs
RMS Output Noise	V_{NOISE}	$T_A=25^{\circ}C$ $10Hz \leq f \leq 100kHz$		200		μV_{rms}

Note 4: Dropout voltage is defined as the input-to-output differential when the output voltage drops to 98% of its nominal value which is measured at $V_{OUT}+1V$ applied to V_{IN} .

Note 5: Turn-on time is time measured between the enable input just exceeding V_{IH} and the output voltage just reaching 95% of its nominal value.



300mA FIXED OUTPUT VOLTAGE LDO REGULATOR AP2115

Electrical Characteristics (Continued)

AP2115-3.0V Electrical Characteristics

$V_{IN}=V_{OUT}+1V$, $T_A=25^{\circ}C$, $C_{IN}=1\mu F$, $C_L=1\mu F$, unless otherwise specified.

Parameter	Symbol	Conditions	Min	Typ	Max	Unit
Output Voltage	V_{OUT}	$1mA \leq I_{OUT} \leq 30mA$	2.94	3.0	3.06	V
Output Current	I_{OUT}		300			mA
Current Limit				500		mA
Quiescent Current				80	150	μA
Ground Pin Current	I_{GND}	$I_{OUT}=300mA$		90	150	μA
Dropout Voltage (Note 4)	V_{DROP}	$I_{OUT}=1mA$		1	5	mV
		$I_{OUT}=50mA$		50	75	
		$I_{OUT}=200mA$		200	300	
		$I_{OUT}=300mA$		300	450	
Load Regulation	V_{RLOAD}	$1mA \leq I_{OUT} \leq 300mA$		12	30	mV
Line Regulation	V_{RLINE}	$V_{OUT}+0.5V \leq V_{IN} \leq 6V$ $I_{OUT}=30mA$		4	15	mV
CE/ \overline{CE} Input High Threshold	V_{IH}		1.5			V
CE/ \overline{CE} Input Low Threshold	V_{IL}				0.4	V
CE/ \overline{CE} Bias Current	I_{SD}				100	nA
Shutdown Supply Current	I_{GSD}	$V_{OUT}=0V$		0.1	1	μA
Thermal Shutdown Temperature	T_{SD}			165		$^{\circ}C$
Power Supply Ripple Rejection	PSRR	Ripple 0.5V _{P-P} $f=1kHz$, $I_{OUT}=30mA$		70		dB
Output Voltage Temperature Coefficient	$\Delta V_{OUT}/\Delta T$	$I_{OUT}=30mA$ $-40^{\circ}C \leq T_j \leq 125^{\circ}C$		300		$\mu V/^{\circ}C$
Short Current Limit	I_{LIMIT}	$V_{OUT}=0V$		450		mA
Turn-on Time (Note 5)	T_{ON}			60		μs
RMS Output Noise	V_{NOISE}	$T_A=25^{\circ}C$ $10Hz \leq f \leq 100kHz$		200		μV_{rms}

Note 4: Dropout voltage is defined as the input-to-output differential when the output voltage drops to 98% of its nominal value which is measured at $V_{OUT}+1V$ applied to V_{IN} .

Note 5: Turn-on time is time measured between the enable input just exceeding V_{IH} and the output voltage just reaching 95% of its nominal value.



300mA FIXED OUTPUT VOLTAGE LDO REGULATOR

AP2115

Electrical Characteristics (Continued)

AP2115-3.3V Electrical Characteristics

$V_{IN}=V_{OUT}+1V$, $T_A=25^{\circ}C$, $C_{IN}=1\mu F$, $C_L=1\mu F$, unless otherwise specified.

Parameter	Symbol	Conditions	Min	Typ	Max	Unit
Output Voltage	V_{OUT}	$1mA \leq I_{OUT} \leq 30mA$	3.234	3.3	3.366	V
Output Current	I_{OUT}		300			mA
Current Limit				500		mA
Quiescent Current				80	150	μA
Ground Pin Current	I_{GND}	$I_{OUT}=300mA$		90	150	μA
Dropout Voltage (Note 4)	V_{DROP}	$I_{OUT}=1mA$		1	5	mV
		$I_{OUT}=50mA$		50	75	
		$I_{OUT}=200mA$		200	300	
		$I_{OUT}=300mA$		300	450	
Load Regulation	V_{RLOAD}	$1mA \leq I_{OUT} \leq 300mA$		13.2	33	mV
Line Regulation	V_{RLINE}	$V_{OUT}+0.5V \leq V_{IN} \leq 6V$ $I_{OUT}=30mA$		4	15	mV
CE/ \overline{CE} Input High Threshold	V_{IH}		1.5			V
CE/ \overline{CE} Input Low Threshold	V_{IL}				0.4	V
CE/ \overline{CE} Bias Current	I_{SD}				100	nA
Shutdown Supply Current	I_{GSD}	$V_{OUT}=0V$		0.1	1	μA
Thermal Shutdown Temperature	T_{SD}			165		$^{\circ}C$
Power Supply Ripple Rejection	PSRR	Ripple 0.5V _{P-P} $f=1kHz$, $I_{OUT}=30mA$		70		dB
Output Voltage Temperature Coefficient	$\Delta V_{OUT}/\Delta T$	$I_{OUT}=30mA$ $-40^{\circ}C \leq T_j \leq 125^{\circ}C$		330		$\mu V/^{\circ}C$
Short Current Limit	I_{LIMIT}	$V_{OUT}=0V$		450		mA
Turn-on Time (Note 5)	T_{ON}			60		μs
RMS Output Noise	V_{NOISE}	$T_A=25^{\circ}C$ $10Hz \leq f \leq 100kHz$		200		μV_{rms}

Note 4: Dropout voltage is defined as the input-to-output differential when the output voltage drops to 98% of its nominal value which is measured at $V_{OUT}+1V$ applied to V_{IN} .

Note 5: Turn-on time is time measured between the enable input just exceeding V_{IH} and the output voltage just reaching 95% of its nominal value.



300mA FIXED OUTPUT VOLTAGE LDO REGULATOR

AP2115

Typical Performance Characteristics

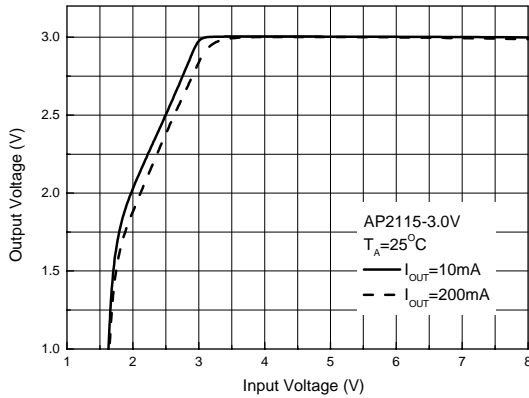

Figure 4. Output Voltage vs. Input Voltage

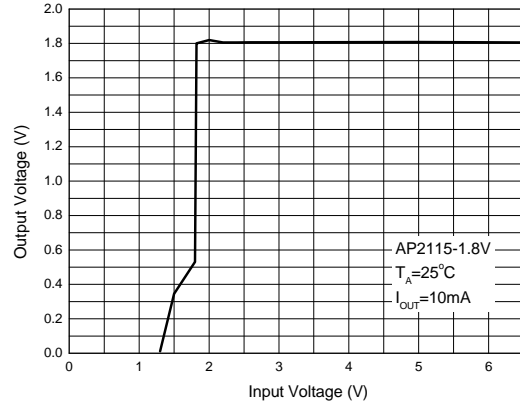

Figure 5. Output Voltage vs. Input Voltage

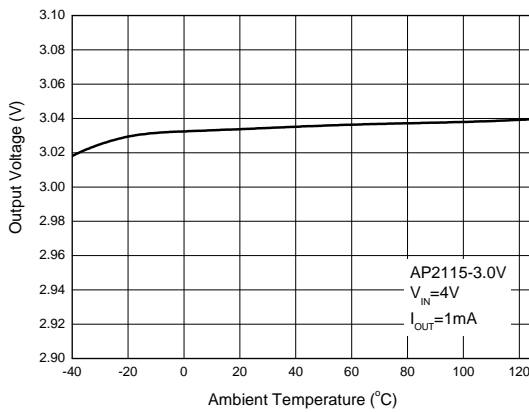

Figure 6. Output Voltage vs. Temperature

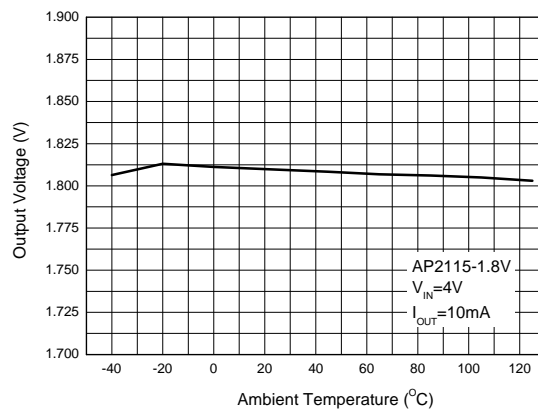

Figure 7. Output Voltage vs. Temperature



300mA FIXED OUTPUT VOLTAGE LDO REGULATOR

AP2115

Typical Performance Characteristics

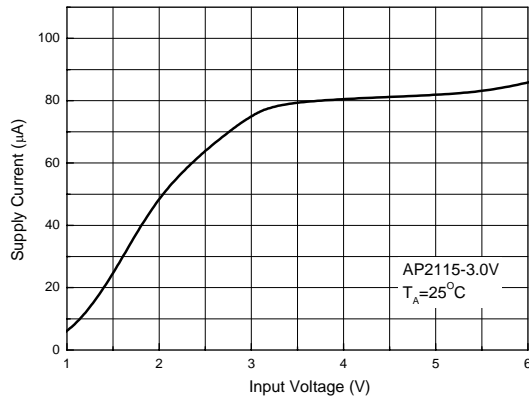

Figure 8. Input Voltage vs. Supply Current (No Load)

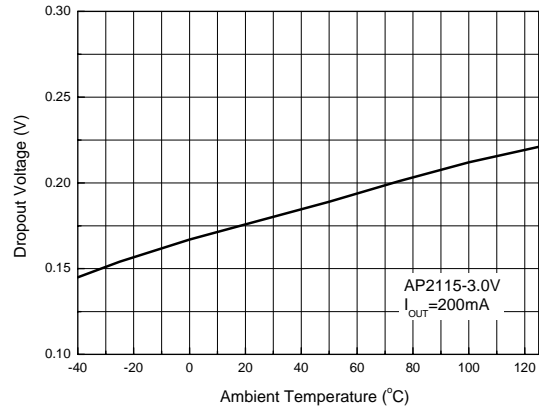

Figure 9. Dropout Voltage vs. Ambient Temperature

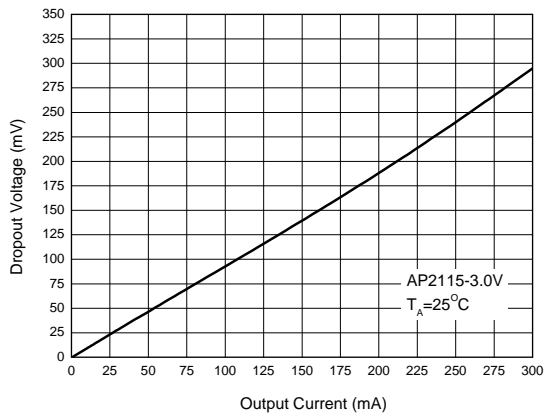

Figure 10. Dropout Voltage vs. Output Current

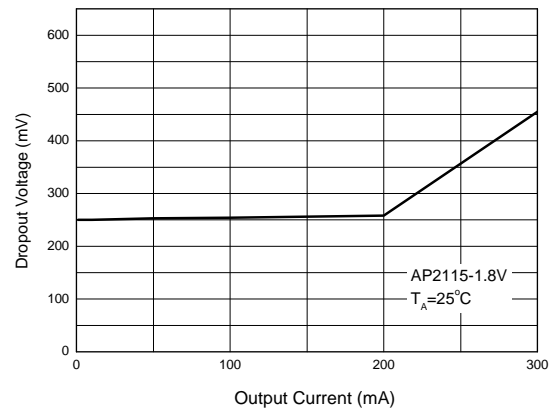

Figure 11. Dropout Voltage vs. Output Current



300mA FIXED OUTPUT VOLTAGE LDO REGULATOR AP2115

Typical Performance Characteristics (Continued)

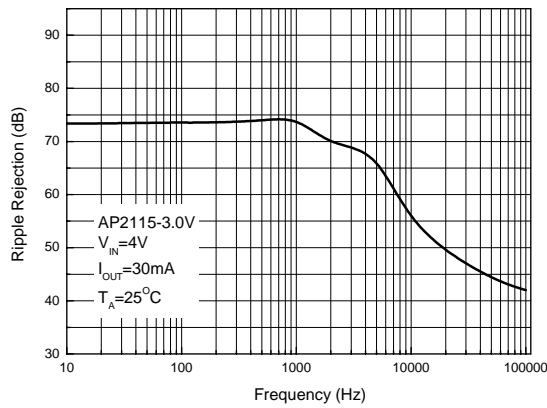

Figure 12. Ripple Rejection vs. Frequency

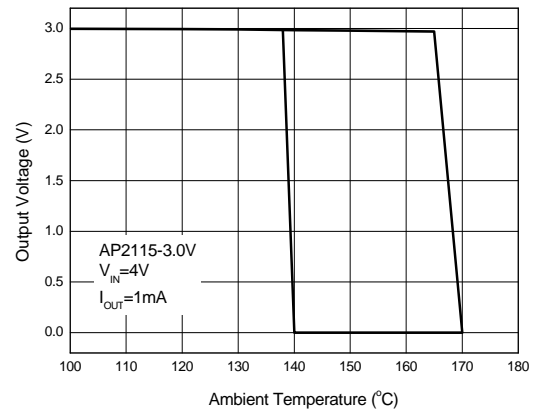

Figure 13. Output Voltage vs. Ambient Temperature

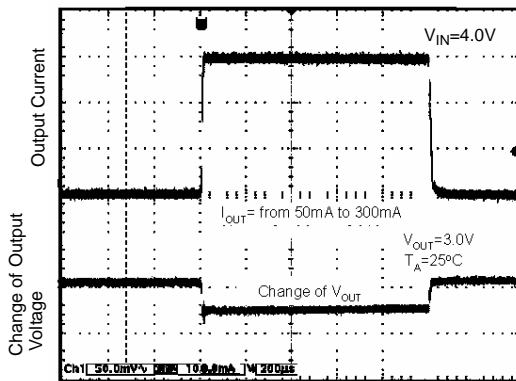

Figure 14. Load Transient

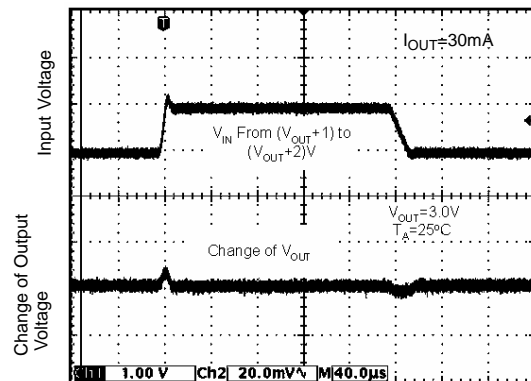

Figure 15. Line Transient



300mA FIXED OUTPUT VOLTAGE LDO REGULATOR

AP2115

Typical Performance Characteristics (Continued)

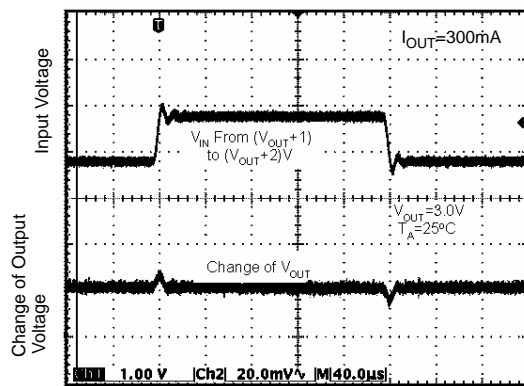

Figure 16. Line Transient

**300mA FIXED OUTPUT VOLTAGE LDO REGULATOR****AP2115****Typical Application**

Figure 17. Typical Application of AP2115

Note: Filter capacitors are required at the AP2115's input and output. $1\mu\text{F}$ capacitors are required at the input. The minimum output capacitance required for stability should be $\geq 1\mu\text{F}$ with ESR from 0.1Ω to 10Ω .

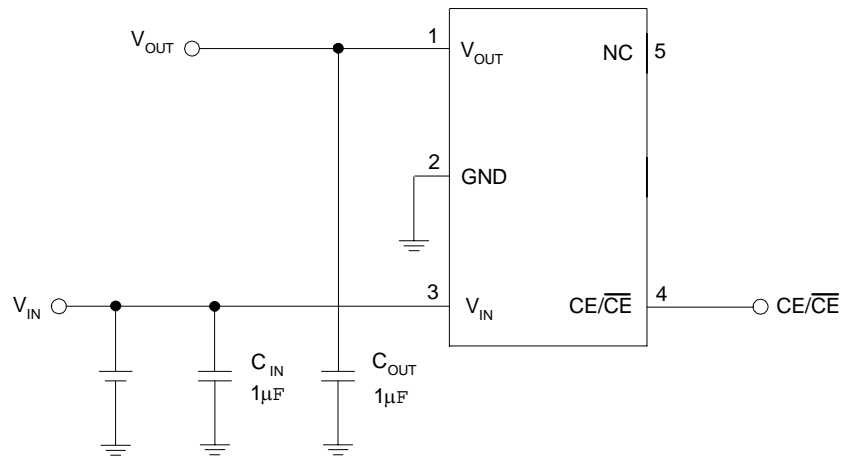

300mA FIXED OUTPUT VOLTAGE LDO REGULATOR AP2115

Mechanical Dimensions

SOT-23-5

Unit: mm(inch)

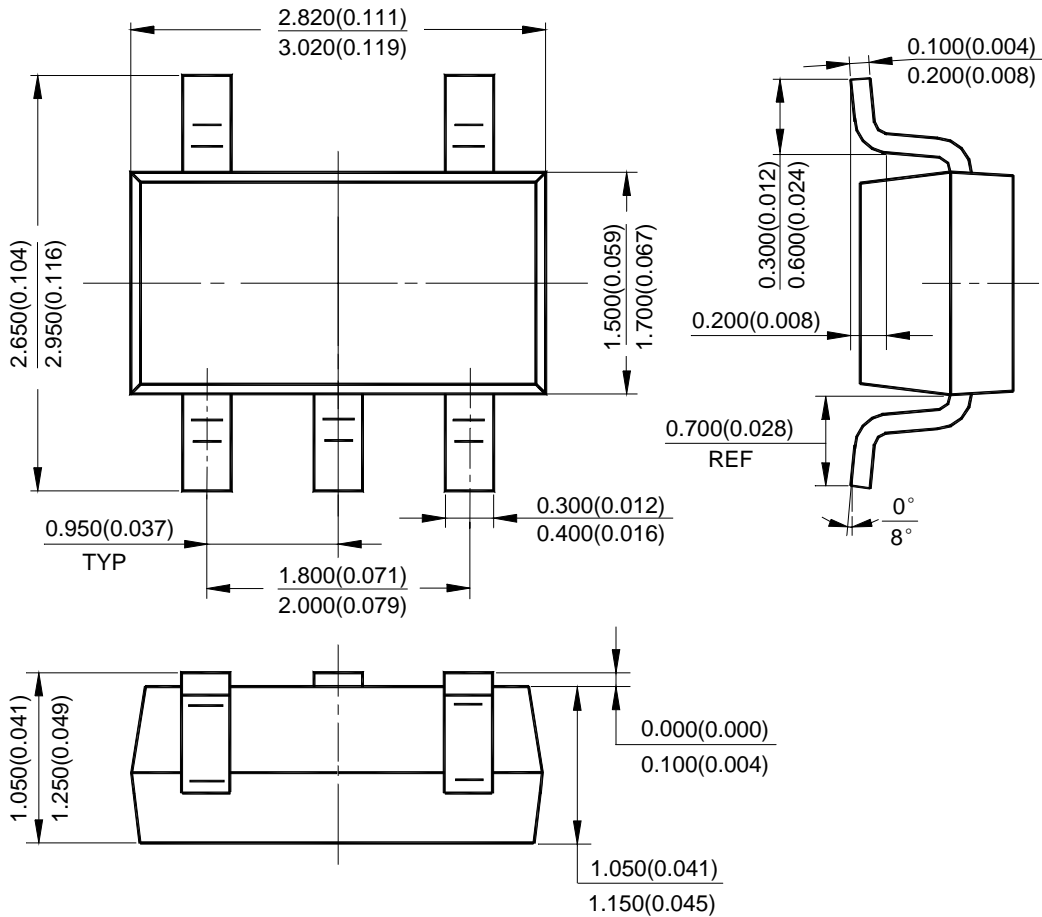



BCD Semiconductor Manufacturing Limited

<http://www.bcdsemi.com>

IMPORTANT NOTICE

BCD Semiconductor Manufacturing Limited reserves the right to make changes without further notice to any products or specifications herein. BCD Semiconductor Manufacturing Limited does not assume any responsibility for use of any its products for any particular purpose, nor does BCD Semiconductor Manufacturing Limited assume any liability arising out of the application or use of any its products or circuits. BCD Semiconductor Manufacturing Limited does not convey any license under its patent rights or other rights nor the rights of others.

MAIN SITE

BCD Semiconductor Manufacturing Limited
- Wafer Fab
Shanghai SIM-BCD Semiconductor Manufacturing Limited
800, Yi Shan Road, Shanghai 200233, China
Tel: +86-21-6485 1491, Fax: +86-21-5450 0008

BCD Semiconductor Manufacturing Limited
- IC Design Group
Advanced Analog Circuits (Shanghai) Corporation
8F, Zone B, 900, Yi Shan Road, Shanghai 200233, China
Tel: +86-21-6495 9539, Fax: +86-21-6485 9673

REGIONAL SALES OFFICE

Shenzhen Office
Shanghai SIM-BCD Semiconductor Manufacturing Co., Ltd. Shenzhen Office
Advanced Analog Circuits (Shanghai) Corporation Shenzhen Office
27B, Tower C, 2070, Middle Shen Nan Road, Shenzhen 518031, China
Tel: +86-755-8368 3987, Fax: +86-755-8368 3166

Taiwan Office
BCD Semiconductor (Taiwan) Company Limited
4F, 298-1, Rui Guang Road, Nei-Hu District, Taipei,
Taiwan
Tel: +886-2-2656 2808, Fax: +886-2-2656 2806

USA Office
BCD Semiconductor Corporation
3170 De La Cruz Blvd., Suite 105, Santa Clara,
CA 95054-2411, U.S.A
Tel: +1-408-988 6388, Fax: +1-408-988 6386