

HIGH SPEED, EXTREMELY LOW NOISE LDO REGULATOR**AP2120****General Description**

The AP2120 series are positive voltage regulator ICs fabricated by CMOS process. Each of these ICs consists of a voltage reference, an error amplifier, a resistor network for setting output voltage, a current limit circuit for current protection.

The AP2120 series feature high supply voltage ripple rejection, low dropout voltage, low noise, high output voltage accuracy, and low current consumption which make them ideal for use in various battery-powered devices.

The AP2120 series have 1.2V, 1.3V, 1.5V, 1.8V, 2.5V, 2.8V, 3.0V, 3.2V, 3.3V and 5.0V versions.

The AP2120 are available in standard SOT-23 package.

Features

- Low Dropout Voltage at $I_{OUT}=100mA$: 200mV Typical (Except 1.2V, 1.3V and 1.5V Versions)
- Low Quiescent Current: 25 μA Typical
- High Ripple Rejection: 65dB Typical ($f=1kHz$)
- Output Current: More Than 150mA (250mA Limit)
- Extremely Low Noise: 15 μV_{rms} @ $V_{OUT}=1.2V, 1.3V, 1.5V$ (10Hz to 100kHz)
- Excellent Line Regulation: 4mV Typical
- Excellent Load Regulation: 12mV Typical
- High Output Voltage Accuracy: $\pm 2\%$
- Excellent Line Transient Response and Load Transient Response
- Compatible with Low ESR Ceramic Capacitor (as Low as 1 μF)

Applications

- Mobile Phones, Cordless Phones
- Wireless Communication Equipment
- Portable Games
- Cameras, Video Recorders
- Sub-board Power Supplies for Telecom Equipment
- Battery Powered Equipment

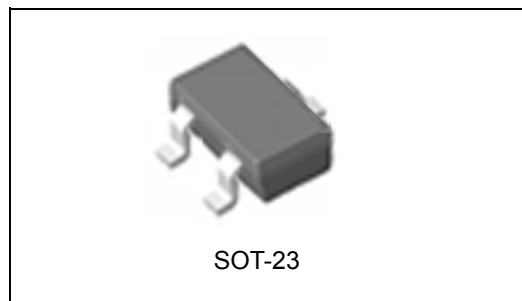

Figure 1. Package Types of AP2120

Pin Configuration

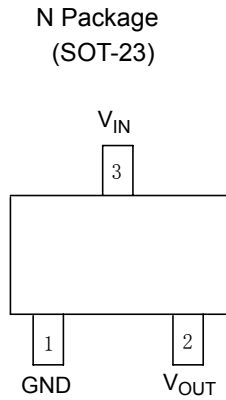

Figure 2. Pin Configuration of AP2120 (Top View)

Pin Description

Pin Number	Pin Name	Function
1	GND	Ground
2	V _{OUT}	Regulated Output Voltage
3	V _{IN}	Input Voltage

Functional Block Diagram

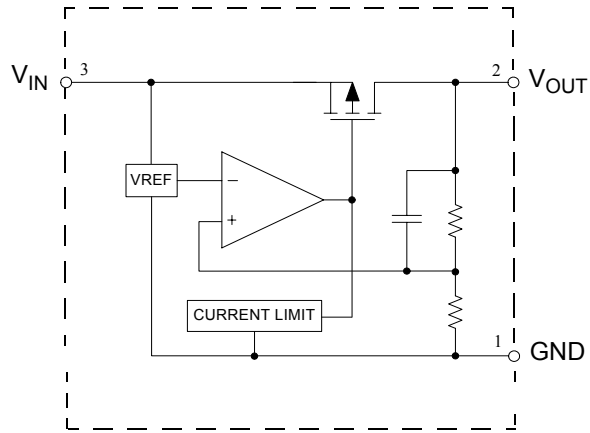

Figure 3. Functional Block Diagram of AP2120



HIGH SPEED, EXTREMELY LOW NOISE LDO REGULATOR

AP2120

Ordering Information

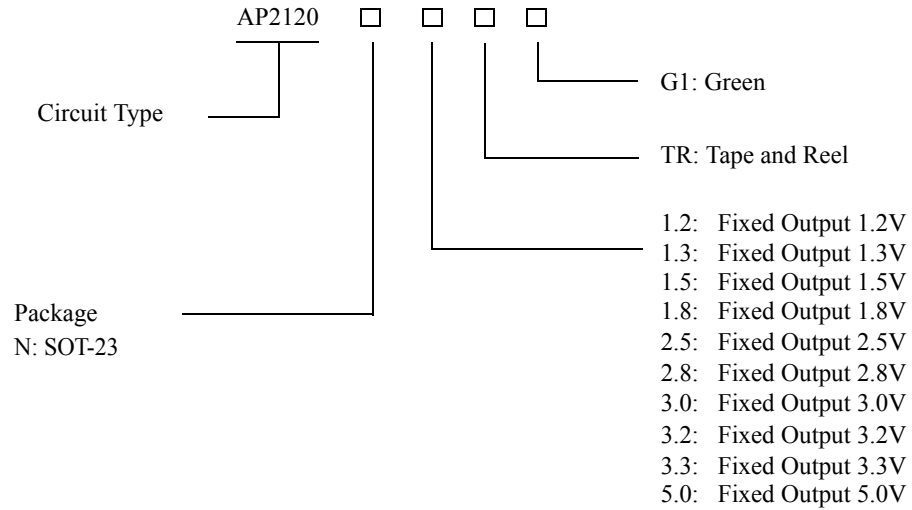

Package	Temperature Range	Part Number	Marking ID	Packing Type
SOT-23	-40 to 85°C	AP2120N-1.2TRG1	GR4	Tape & Reel
		AP2120N-1.3TRG1	GR5	Tape & Reel
		AP2120N-1.5TRG1	GR6	Tape & Reel
		AP2120N-1.8TRG1	GR7	Tape & Reel
		AP2120N-2.5TRG1	GR8	Tape & Reel
		AP2120N-2.8TRG1	GR9	Tape & Reel
		AP2120N-3.0TRG1	GS2	Tape & Reel
		AP2120N-3.2TRG1	GS3	Tape & Reel
		AP2120N-3.3TRG1	GS4	Tape & Reel
		AP2120N-5.0TRG1	GS5	Tape & Reel

BCD Semiconductor's products, as designated with "G1" suffix in the part number, are RoHS compliant and Green.

**HIGH SPEED, EXTREMELY LOW NOISE LDO REGULATOR****AP2120****Absolute Maximum Ratings (Note 1)**

Parameter	Symbol	Value	Unit
Input Voltage	V_{IN}	6.5	V
Enable Input Voltage	V_{CE}	-0.3 to $V_{IN}+0.3$	V
Output Current	I_{OUT}	300	mA
Junction Temperature	T_J	150	°C
Storage Temperature Range	T_{STG}	-65 to 150	°C
Lead Temperature (Soldering, 10sec)	T_{LEAD}	260	°C
Thermal Resistance (Note 2)	θ_{JA}	250	°C/W
ESD (Human Body Model)	ESD	2000	V
ESD (Machine Model)	ESD	200	V

Note 1: Stresses greater than those listed under "Absolute Maximum Ratings" may cause permanent damage to the device. These are stress ratings only, and functional operation of the device at these or any other conditions beyond those indicated under "Recommended Operating Conditions" is not implied. Exposure to "Absolute Maximum Ratings" for extended periods may affect device reliability.

Note 2: Absolute maximum ratings indicate limits beyond which damage to the component may occur. Electrical specifications do not apply when operating the device outside of its operating ratings. The maximum allowable power dissipation is a function of the maximum junction temperature, $T_{J(max)}$, the junction-to-ambient thermal resistance, θ_{JA} , and the ambient temperature, T_A . The maximum allowable power dissipation at any ambient temperature is calculated using: $P_{D(max)} = (T_{J(max)} - T_A) / \theta_{JA}$. Exceeding the maximum allowable power dissipation will result in excessive die temperature.

Recommended Operating Conditions

Parameter	Symbol	Min	Max	Unit
Input Voltage	V_{IN}	2	6	V
Operating Junction Temperature Range	T_J	-40	85	°C

**HIGH SPEED, EXTREMELY LOW NOISE LDO REGULATOR****AP2120****Electrical Characteristics****AP2120-1.2 Electrical Characteristics** $(V_{IN}=2.2V, T_J=25^{\circ}C, C_{IN}=1\mu F, C_{OUT}=1\mu F, \text{Bold typeface applies over } -40^{\circ}C \leq T_J \leq 85^{\circ}C, \text{ unless otherwise specified.})$

Parameter	Symbol	Conditions	Min	Typ	Max	Unit
Output Voltage	V_{OUT}	$V_{IN}=2.2V$ $1mA \leq I_{OUT} \leq 30mA$	1.176	1.2	1.224	V
Input Voltage	V_{IN}				6	V
Output Current	I_{OUT}	$V_{IN}-V_{OUT}=1V$	150			mA
Load Regulation	V_{RLOAD}	$V_{IN}=2.2V$ $1mA \leq I_{OUT} \leq 80mA$		12	40	mV
Line Regulation	V_{RLINE}	$2.2V \leq V_{IN} \leq 6V$ $I_{OUT}=30mA$		4	16	mV
Dropout Voltage	V_{DROP}	$I_{OUT}=10mA$		700	900	mV
		$I_{OUT}=100mA$		700	900	
		$I_{OUT}=150mA$		700	900	
		$I_{OUT}=200mA$		700	900	
Quiescent Current	I_Q	$V_{IN}=2.2V, I_{OUT}=0mA$		25	50	μA
Power Supply Rejection Ratio	PSRR	Ripple 0.5Vp-p, $f=1kHz$ $V_{IN}=2.2V$		65		dB
Output Voltage Temperature Coefficient	$\Delta V_{OUT}/\Delta T$	$I_{OUT}=30mA$		± 120		$\mu V/^{\circ}C$
	$(\Delta V_{OUT}/V_{OUT})/\Delta T$			± 100		ppm/ $^{\circ}C$
Short Current Limit	I_{LIMIT}	$V_{OUT}=0V$		50		mA
RMS Output Noise	V_{NOISE}	$T_A=25^{\circ}C, I_{OUT}=0$ $10Hz \leq f \leq 100kHz$		15		μV_{rms}

**HIGH SPEED, EXTREMELY LOW NOISE LDO REGULATOR****AP2120****Electrical Characteristics (Continued)****AP2120-1.3 Electrical Characteristics** $(V_{IN}=2.3V, T_J=25^{\circ}C, C_{IN}=1\mu F, C_{OUT}=1\mu F, \text{Bold typeface applies over } -40^{\circ}C \leq T_J \leq 85^{\circ}C, \text{ unless otherwise specified.})$

Parameter	Symbol	Conditions	Min	Typ	Max	Unit
Output Voltage	V_{OUT}	$V_{IN}=2.3V$ $1mA \leq I_{OUT} \leq 30mA$	1.274	1.3	1.326	V
Input Voltage	V_{IN}				6	V
Output Current	I_{OUT}	$V_{IN}-V_{OUT}=1V$	150			mA
Load Regulation	V_{RLOAD}	$V_{IN}=2.3V$ $1mA \leq I_{OUT} \leq 80mA$		12	40	mV
Line Regulation	V_{RLINE}	$2.3V \leq V_{IN} \leq 6V$ $I_{OUT}=30mA$		4	16	mV
Dropout Voltage	V_{DROP}	$I_{OUT}=10mA$		600	800	mV
		$I_{OUT}=100mA$		600	800	
		$I_{OUT}=150mA$		600	800	
		$I_{OUT}=200mA$		600	800	
Quiescent Current	I_Q	$V_{IN}=2.3V, I_{OUT}=0mA$		25	50	μA
Power Supply Rejection Ratio	PSRR	Ripple 0.5Vp-p, $f=1kHz$ $V_{IN}=2.3V$		65		dB
Output Voltage Temperature Coefficient	$\Delta V_{OUT}/\Delta T$	$I_{OUT}=30mA$		± 130		$\mu V/^{\circ}C$
	$(\Delta V_{OUT}/V_{OUT})/\Delta T$			± 100		ppm/ $^{\circ}C$
Short Current Limit	I_{LIMIT}	$V_{OUT}=0V$		50		mA
RMS Output Noise	V_{NOISE}	$T_A=25^{\circ}C, I_{OUT}=0$ $10Hz \leq f \leq 100kHz$		15		μV_{rms}

**HIGH SPEED, EXTREMELY LOW NOISE LDO REGULATOR****AP2120****Electrical Characteristics (Continued)****AP2120-1.5 Electrical Characteristics** $(V_{IN}=2.5V, T_J=25^{\circ}C, C_{IN}=1\mu F, C_{OUT}=1\mu F, \text{Bold typeface applies over } -40^{\circ}C \leq T_J \leq 85^{\circ}C, \text{ unless otherwise specified.})$

Parameter	Symbol	Conditions	Min	Typ	Max	Unit
Output Voltage	V_{OUT}	$V_{IN}=2.5V$ $1mA \leq I_{OUT} \leq 30mA$	1.47	1.5	1.53	V
Input Voltage	V_{IN}				6	V
Output Current	I_{OUT}	$V_{IN}-V_{OUT}=1V$	150			mA
Load Regulation	V_{RLOAD}	$V_{IN}=2.5V$ $1mA \leq I_{OUT} \leq 80mA$		12	40	mV
Line Regulation	V_{RLINE}	$2.3V \leq V_{IN} \leq 6V$ $I_{OUT}=30mA$		4	16	mV
Dropout Voltage	V_{DROP}	$I_{OUT}=10mA$		400	600	mV
		$I_{OUT}=100mA$		400	600	
		$I_{OUT}=150mA$		400	600	
		$I_{OUT}=200mA$		400	600	
Quiescent Current	I_Q	$V_{IN}=2.5V, I_{OUT}=0mA$		25	50	μA
Power Supply Rejection Ratio	PSRR	Ripple 0.5Vp-p, $f=1kHz$ $V_{IN}=2.5V$		65		dB
Output Voltage Temperature Coefficient	$\Delta V_{OUT}/\Delta T$	$I_{OUT}=30mA$		± 150		$\mu V/^{\circ}C$
	$(\Delta V_{OUT}/V_{OUT})/\Delta T$			± 100		ppm/ $^{\circ}C$
Short Current Limit	I_{LIMIT}	$V_{OUT}=0V$		50		mA
RMS Output Noise	V_{NOISE}	$T_A=25^{\circ}C, I_{OUT}=0$ $10Hz \leq f \leq 100kHz$		15		μV_{rms}

**HIGH SPEED, EXTREMELY LOW NOISE LDO REGULATOR****AP2120****Electrical Characteristics (Continued)****AP2120-1.8 Electrical Characteristics**(V_{IN}=2.8V, T_J=25°C, C_{IN}=1μF, C_{OUT}=1μF, **Bold** typeface applies over -40°C≤T_J≤85°C, unless otherwise specified.)

Parameter	Symbol	Conditions	Min	Typ	Max	Unit
Output Voltage	V _{OUT}	V _{IN} =2.8V 1mA≤I _{OUT} ≤30mA	1.764	1.8	1.836	V
Input Voltage	V _{IN}				6	V
Output Current	I _{OUT}	V _{IN} -V _{OUT} =1V	150			mA
Load Regulation	V _{RLOAD}	V _{IN} =2.8V 1mA≤I _{OUT} ≤80mA		12	40	mV
Line Regulation	V _{RLINE}	2.3V≤V _{IN} ≤6V I _{OUT} =30mA		4	16	mV
Dropout Voltage	V _{DROP}	I _{OUT} =10mA		20	40	mV
		I _{OUT} =100mA		200	300	
		I _{OUT} =150mA		300	500	
Quiescent Current	I _Q	V _{IN} =2.8V, I _{OUT} =0mA		25	50	μA
Power Supply Rejection Ratio	PSRR	Ripple 0.5Vp-p, f=1kHz V _{IN} =2.8V		65		dB
Output Voltage Temperature Coefficient	ΔV _{OUT} /ΔT	I _{OUT} =30mA		±180		μV/°C
	(ΔV _{OUT} /V _{OUT})/ΔT			±100		ppm/°C
Short Current Limit	I _{LIMIT}	V _{OUT} =0V		50		mA
RMS Output Noise	V _{NOISE}	T _A =25°C 10Hz ≤f≤100kHz		30		μV _{rms}

**HIGH SPEED, EXTREMELY LOW NOISE LDO REGULATOR****AP2120****Electrical Characteristics (Continued)****AP2120-2.5 Electrical Characteristics** $(V_{IN}=3.5V, T_J=25^{\circ}C, C_{IN}=1\mu F, C_{OUT}=1\mu F, \text{Bold typeface applies over } -40^{\circ}C \leq T_J \leq 85^{\circ}C, \text{ unless otherwise specified.})$

Parameter	Symbol	Conditions	Min	Typ	Max	Unit
Output Voltage	V_{OUT}	$V_{IN}=3.5V$ $1mA \leq I_{OUT} \leq 30mA$	2.45	2.5	2.55	V
Input Voltage	V_{IN}				6	V
Output Current	I_{OUT}	$V_{IN}-V_{OUT}=1V$	150			mA
Load Regulation	V_{RLOAD}	$V_{IN}=3.5V$ $1mA \leq I_{OUT} \leq 80mA$		12	40	mV
Line Regulation	V_{RLINE}	$3V \leq V_{IN} \leq 6V$ $I_{OUT}=30mA$		4	16	mV
Dropout Voltage	V_{DROP}	$I_{OUT}=10mA$		20	40	mV
		$I_{OUT}=100mA$		200	300	
		$I_{OUT}=150mA$		300	500	
Quiescent Current	I_Q	$V_{IN}=3.5V, I_{OUT}=0mA$		25	50	μA
Power Supply Rejection Ratio	PSRR	Ripple 0.5Vp-p, $f=1kHz$ $V_{IN}=3.5V$		65		dB
Output Voltage Temperature Coefficient	$\Delta V_{OUT}/\Delta T$	$I_{OUT}=30mA$		± 250		$\mu V/^{\circ}C$
	$(\Delta V_{OUT}/V_{OUT})/\Delta T$			± 100		ppm/ $^{\circ}C$
Short Current Limit	I_{LIMIT}	$V_{OUT}=0V$		50		mA
RMS Output Noise	V_{NOISE}	$T_A=25^{\circ}C$ $10Hz \leq f \leq 100kHz$		30		μV_{rms}



HIGH SPEED, EXTREMELY LOW NOISE LDO REGULATOR **AP2120**

Electrical Characteristics (Continued)

AP2120-2.8 Electrical Characteristics

($V_{IN}=3.8V$, $T_J=25^{\circ}C$, $C_{IN}=1\mu F$, $C_{OUT}=1\mu F$, **Bold** typeface applies over $-40^{\circ}C \leq T_J \leq 85^{\circ}C$, unless otherwise specified.)

Parameter	Symbol	Conditions	Min	Typ	Max	Unit
Output Voltage	V_{OUT}	$V_{IN}=3.8V$ $1mA \leq I_{OUT} \leq 30mA$	2.744	2.8	2.856	V
Input Voltage	V_{IN}				6	V
Output Current	I_{OUT}	$V_{IN}-V_{OUT}=1V$	150			mA
Load Regulation	V_{RLOAD}	$V_{IN}=3.8V$ $1mA \leq I_{OUT} \leq 80mA$		12	40	mV
Line Regulation	V_{RLINE}	$3.3V \leq V_{IN} \leq 6V$ $I_{OUT}=30mA$		4	16	mV
Dropout Voltage	V_{DROP}	$I_{OUT}=10mA$		20	40	mV
		$I_{OUT}=100mA$		200	300	
		$I_{OUT}=150mA$		300	500	
Quiescent Current	I_Q	$V_{IN}=3.8V$, $I_{OUT}=0mA$		25	50	μA
Power Supply Rejection Ratio	PSRR	Ripple 0.5Vp-p, $f=1kHz$ $V_{IN}=3.8V$		65		dB
Output Voltage Temperature Coefficient	$\Delta V_{OUT}/\Delta T$	$I_{OUT}=30mA$		± 280		$\mu V/^{\circ}C$
	$(\Delta V_{OUT}/V_{OUT})/\Delta T$			± 100		ppm/ $^{\circ}C$
Short Current Limit	I_{LIMIT}	$V_{OUT}=0V$		50		mA
RMS Output Noise	V_{NOISE}	$T_A=25^{\circ}C$ $10Hz \leq f \leq 100kHz$		30		μV_{rms}



HIGH SPEED, EXTREMELY LOW NOISE LDO REGULATOR

AP2120

Electrical Characteristics (Continued)

AP2120-3.0 Electrical Characteristics

($V_{IN}=4V$, $T_J=25^{\circ}C$, $C_{IN}=1\mu F$, $C_{OUT}=1\mu F$, **Bold** typeface applies over $-40^{\circ}C \leq T_J \leq 85^{\circ}C$, unless otherwise specified.)

Parameter	Symbol	Conditions	Min	Typ	Max	Unit
Output Voltage	V_{OUT}	$V_{IN}=4V$ $1mA \leq I_{OUT} \leq 30mA$	2.94	3.0	3.06	V
Input Voltage	V_{IN}				6	V
Output Current	I_{OUT}	$V_{IN}-V_{OUT}=1V$	150			mA
Load Regulation	V_{RLOAD}	$V_{IN}=4V$ $1mA \leq I_{OUT} \leq 80mA$		12	40	mV
Line Regulation	V_{RLINE}	$3.5V \leq V_{IN} \leq 6V$ $I_{OUT}=30mA$		4	16	mV
Dropout Voltage	V_{DROP}	$I_{OUT}=10mA$		20	40	mV
		$I_{OUT}=100mA$		200	300	
		$I_{OUT}=150mA$		300	500	
Quiescent Current	I_Q	$V_{IN}=4V$, $I_{OUT}=0mA$		25	50	μA
Power Supply Rejection Ratio	PSRR	Ripple 0.5Vp-p, $f=1kHz$ $V_{IN}=4V$		65		dB
Output Voltage Temperature Coefficient	$\Delta V_{OUT}/\Delta T$	$I_{OUT}=30mA$		± 300		$\mu V/^{\circ}C$
	$(\Delta V_{OUT}/V_{OUT})/\Delta T$			± 100		ppm/ $^{\circ}C$
Short Current Limit	I_{LIMIT}	$V_{OUT}=0V$		50		mA
RMS Output Noise	V_{NOISE}	$T_A=25^{\circ}C$ $10Hz \leq f \leq 100kHz$		30		μV_{rms}

**HIGH SPEED, EXTREMELY LOW NOISE LDO REGULATOR****AP2120****Electrical Characteristics (Continued)****AP2120-3.2 Electrical Characteristics** $(V_{IN}=4.2V, T_J=25^{\circ}C, C_{IN}=1\mu F, C_{OUT}=1\mu F, \text{Bold typeface applies over } -40^{\circ}C \leq T_J \leq 85^{\circ}C, \text{ unless otherwise specified.})$

Parameter	Symbol	Conditions	Min	Typ	Max	Unit
Output Voltage	V_{OUT}	$V_{IN}=4.2V$ $1mA \leq I_{OUT} \leq 30mA$	3.136	3.2	3.264	V
Input Voltage	V_{IN}				6	V
Output Current	I_{OUT}	$V_{IN}-V_{OUT}=1V$	150			mA
Load Regulation	V_{RLOAD}	$V_{IN}=4.2V$ $1mA \leq I_{OUT} \leq 80mA$		12	40	mV
Line Regulation	V_{RLINE}	$3.7V \leq V_{IN} \leq 6V$ $I_{OUT}=30mA$		4	16	mV
Dropout Voltage	V_{DROP}	$I_{OUT}=10mA$		20	40	mV
		$I_{OUT}=100mA$		200	300	
		$I_{OUT}=150mA$		300	500	
Quiescent Current	I_Q	$V_{IN}=4.2V, I_{OUT}=0mA$		25	50	μA
Power Supply Rejection Ratio	PSRR	Ripple 0.5Vp-p, $f=1kHz$ $V_{IN}=4.2V$		65		dB
Output Voltage Temperature Coefficient	$\Delta V_{OUT}/\Delta T$	$I_{OUT}=30mA$		± 320		$\mu V/^{\circ}C$
	$(\Delta V_{OUT}/V_{OUT})/\Delta T$			± 100		ppm/ $^{\circ}C$
Short Current Limit	I_{LIMIT}	$V_{OUT}=0V$		50		mA
RMS Output Noise	V_{NOISE}	$T_A=25^{\circ}C$ $10Hz \leq f \leq 100kHz$		30		μV_{rms}

**HIGH SPEED, EXTREMELY LOW NOISE LDO REGULATOR****AP2120****Electrical Characteristics (Continued)****AP2120-3.3 Electrical Characteristics**(V_{IN}=4.3V, T_J=25°C, C_{IN}=1μF, C_{OUT}=1μF, **Bold** typeface applies over -40°C≤T_J≤85°C, unless otherwise specified.)

Parameter	Symbol	Conditions	Min	Typ	Max	Unit
Output Voltage	V _{OUT}	V _{IN} =4.3V 1mA≤I _{OUT} ≤30mA	3.234	3.3	3.366	V
Input Voltage	V _{IN}				6	V
Output Current	I _{OUT}	V _{IN} -V _{OUT} =1V	150			mA
Load Regulation	V _{RLOAD}	V _{IN} =4.3V 1mA≤I _{OUT} ≤80mA		12	40	mV
Line Regulation	V _{RLINE}	3.8V≤V _{IN} ≤6V I _{OUT} =30mA		4	16	mV
Dropout Voltage	V _{DROP}	I _{OUT} =10mA		20	40	mV
		I _{OUT} =100mA		200	300	
		I _{OUT} =150mA		300	500	
Quiescent Current	I _Q	V _{IN} =4.3V, I _{OUT} =0mA		25	50	μA
Power Supply Rejection Ratio	PSRR	Ripple 0.5Vp-p, f=1kHz V _{IN} =4.3V		65		dB
Output Voltage Temperature Coefficient	$\frac{\Delta V_{OUT}}{\Delta T}$	I _{OUT} =30mA		±330		μV/°C
	$(\frac{\Delta V_{OUT}}{V_{OUT}})/\Delta T$			±100		ppm/°C
Short Current Limit	I _{LIMIT}	V _{OUT} =0V		50		mA
RMS Output Noise	V _{NOISE}	T _A =25°C 10Hz≤f≤100kHz		30		μVrms



HIGH SPEED, EXTREMELY LOW NOISE LDO REGULATOR **AP2120**

Electrical Characteristics (Continued)

AP2120-5.0 Electrical Characteristics

($V_{IN}=6.0V$, $T_J=25^{\circ}C$, $C_{IN}=1\mu F$, $C_{OUT}=1\mu F$, **Bold** typeface applies over $-40^{\circ}C \leq T_J \leq 85^{\circ}C$, unless otherwise specified.)

Parameter	Symbol	Conditions	Min	Typ	Max	Unit
Output Voltage	V_{OUT}	$V_{IN}=6.0V$ $1mA \leq I_{OUT} \leq 30mA$	4.9	5.0	5.1	V
Input Voltage	V_{IN}				6	V
Output Current	I_{OUT}	$V_{IN}-V_{OUT}=1V$	150			mA
Load Regulation	V_{RLOAD}	$V_{IN}=4.3V$ $1mA \leq I_{OUT} \leq 80mA$		12	40	mV
Line Regulation	V_{RLINE}	$5.5V \leq V_{IN} \leq 6V$ $I_{OUT}=30mA$		4	16	mV
Dropout Voltage	V_{DROP}	$I_{OUT}=10mA$		20	40	mV
		$I_{OUT}=100mA$		200	300	
		$I_{OUT}=150mA$		300	500	
Quiescent Current	I_Q	$V_{IN}=6.0V$, $I_{OUT}=0mA$		25	50	μA
Power Supply Rejection Ratio	PSRR	Ripple 0.5Vp-p, $f=1kHz$ $V_{IN}=6.0V$		65		dB
Output Voltage Temperature Coefficient	$\Delta V_{OUT}/\Delta T$	$I_{OUT}=30mA$		± 330		$\mu V/^{\circ}C$
	$(\Delta V_{OUT}/V_{OUT})/\Delta T$			± 100		ppm/ $^{\circ}C$
Short Current Limit	I_{LIMIT}	$V_{OUT}=0V$		50		mA
RMS Output Noise	V_{NOISE}	$T_A=25^{\circ}C$ $10Hz \leq f \leq 100kHz$		30		μV_{rms}

Typical Performance Characteristics

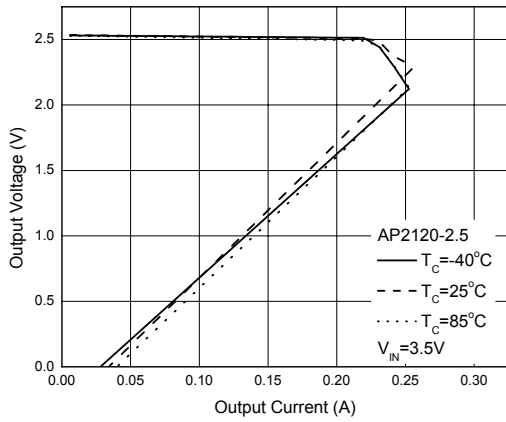

Figure 4. Output Voltage vs. Output Current

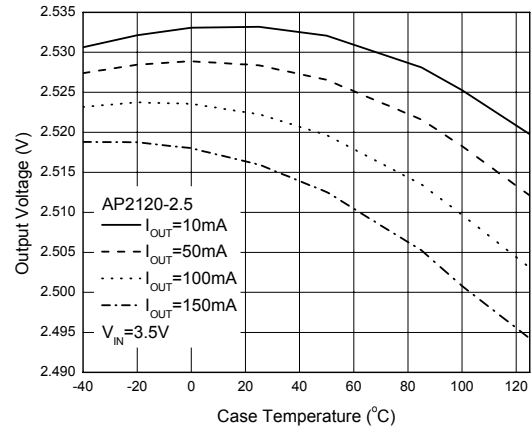

Figure 5. Output Voltage vs. Case Temperature

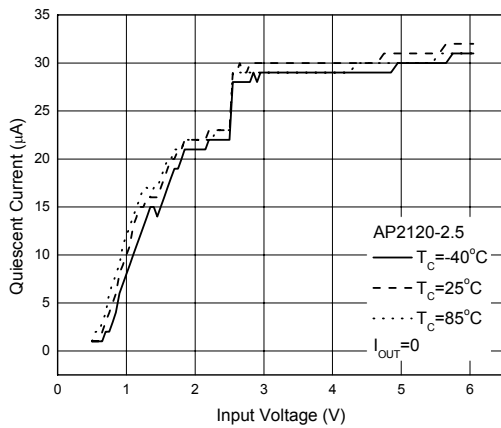

Figure 6. Quiescent Current vs. Input Voltage

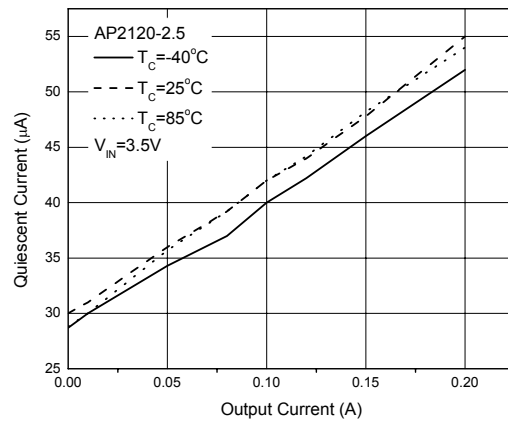

Figure 7. Quiescent Current vs. Output Current

Typical Performance Characteristics (Continued)

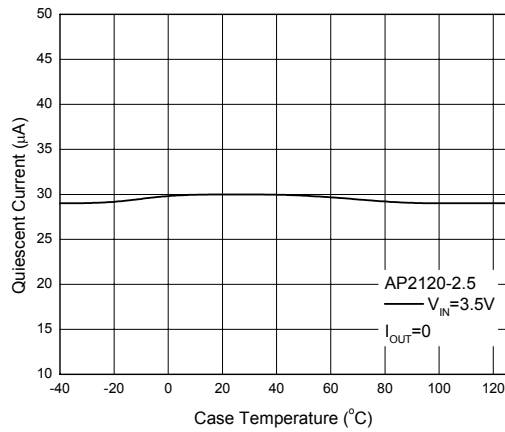

Figure 8. Quiescent Current vs. Case Temperature

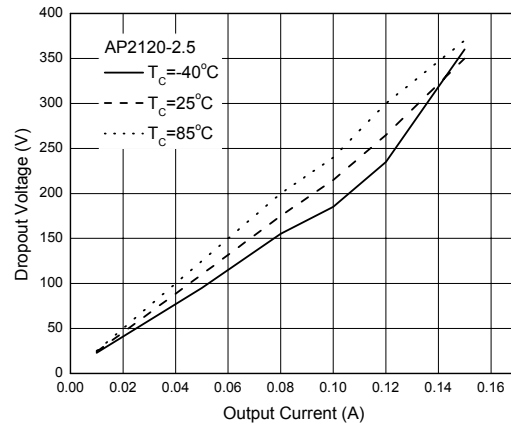

Figure 9. Dropout Voltage vs. Output Current

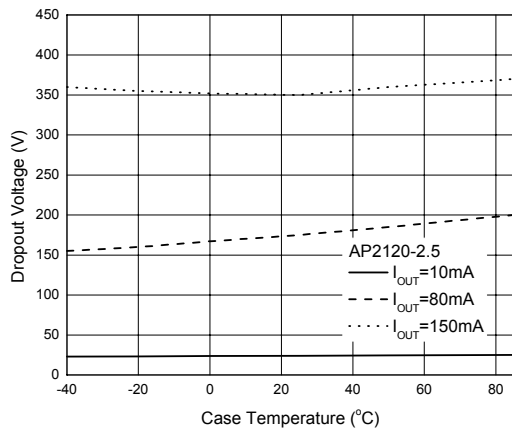

Figure 10. Dropout Voltage vs. Case Temperature

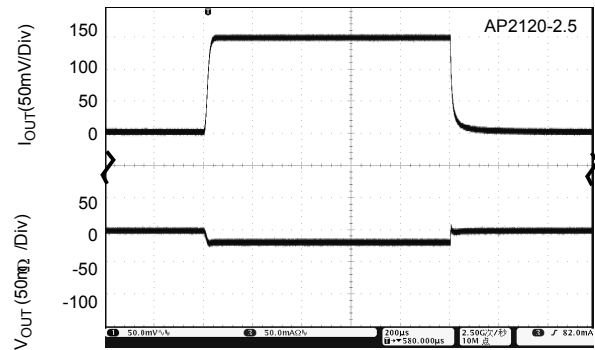

Figure 11. Load Transient ($I_{OUT}=0$ to 150mA)

HIGH SPEED, EXTREMELY LOW NOISE LDO REGULATOR AP2120

Typical Performance Characteristics (Continued)

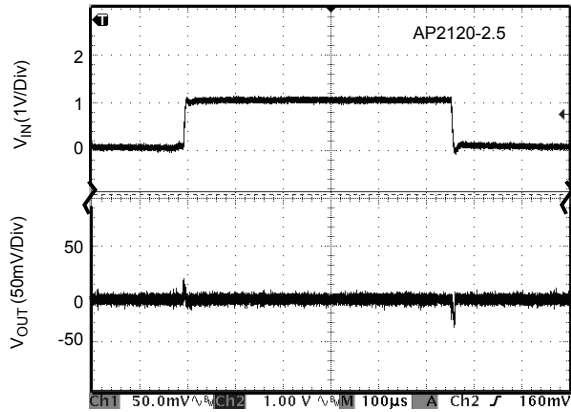

Figure 12. Line Transient
(Condition: $V_{IN}=2.5V$ to $3.5V$, $I_{OUT}=10mA$)

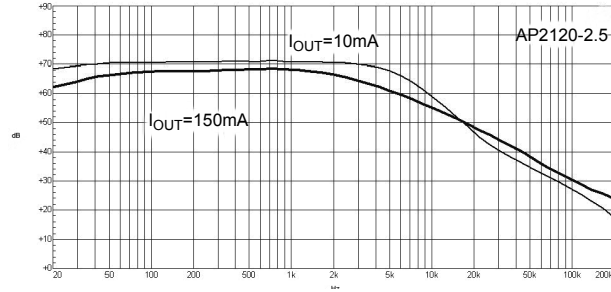

Figure 13. PSRR vs. Frequency

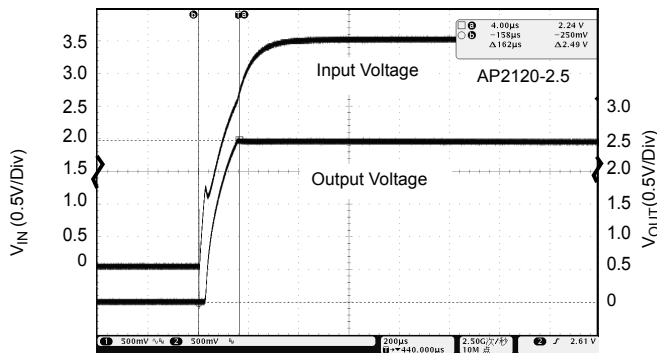
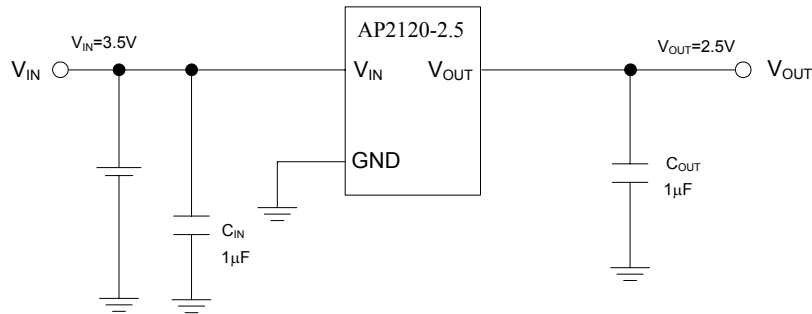

Figure 14. Start-up

Typical Application

Note: Filter capacitors are required at the AP2120's input and output. 1µF capacitor is required at the input. The minimum output capacitance required for stability should be more than 1µF with ESR from 0.01Ω to 100Ω. Ceramic capacitors are recommended.

Figure 15. Typical Application of AP2120



BCD Semiconductor Manufacturing Limited

<http://www.bcdsemi.com>

IMPORTANT NOTICE

BCD Semiconductor Manufacturing Limited reserves the right to make changes without further notice to any products or specifications herein. BCD Semiconductor Manufacturing Limited does not assume any responsibility for use of any its products for any particular purpose, nor does BCD Semiconductor Manufacturing Limited assume any liability arising out of the application or use of any its products or circuits. BCD Semiconductor Manufacturing Limited does not convey any license under its patent rights or other rights nor the rights of others.

MAIN SITE

- Headquarters
BCD Semiconductor Manufacturing Limited
No. 1600, Zi Xing Road, Shanghai Zizhu Science-based Industrial Park, 200241, China
Tel: +86-21-24162266, Fax: +86-21-24162277

- Wafer Fab
Shanghai SIM-BCD Semiconductor Manufacturing Co., Ltd.
800 Yi Shan Road, Shanghai 200233, China
Tel: +86-21-6485 1491, Fax: +86-21-5450 0008

REGIONAL SALES OFFICE

Shenzhen Office
Shanghai SIM-BCD Semiconductor Manufacturing Co., Ltd., Shenzhen Office
Room E, 5F, Noble Center, No.1006, 3rd Fuzhong Road, Futian District, Shenzhen,
518026, China
Tel: +86-755-8826 7951
Fax: +86-755-8826 7865

Taiwan Office
BCD Semiconductor (Taiwan) Company Limited
4F, 298-1, Rui Guang Road, Nei-Hu District, Taipei,
Taiwan
Tel: +886-2-2656 2808
Fax: +886-2-2656 2806

USA Office
BCD Semiconductor Corp.
30920 Huntwood Ave. Hayward,
CA 94544, USA
Tel: +1-510-324-2988
Fax: +1-510-324-2788