

# TA7713P

## 3 PHASE BI-DIRECTIONAL TYPE MOTOR CONTROL IC

### FEATURES

- FG is not required.  
(System for obtaining rotation signal through position sensing)
- Stop function is provided (Stop speed is selectable.)
- Gain of position sensing circuit is high, and hysteresis is provided.
- Rotation signal output is provided. (Frequency signal of three times the position sensing output (Hall sensor output) can be obtained.)
- External transistor type.

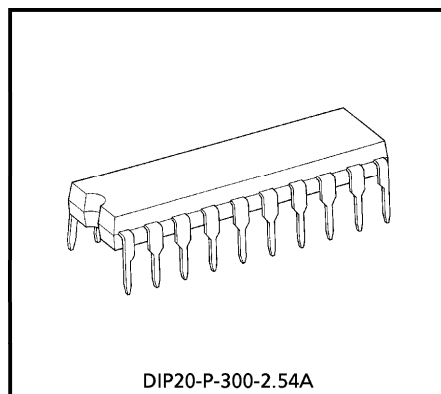

DIP20-P-300-2.54A

Weight : 2.25 g (Typ.)

### BLOCK DIAGRAM

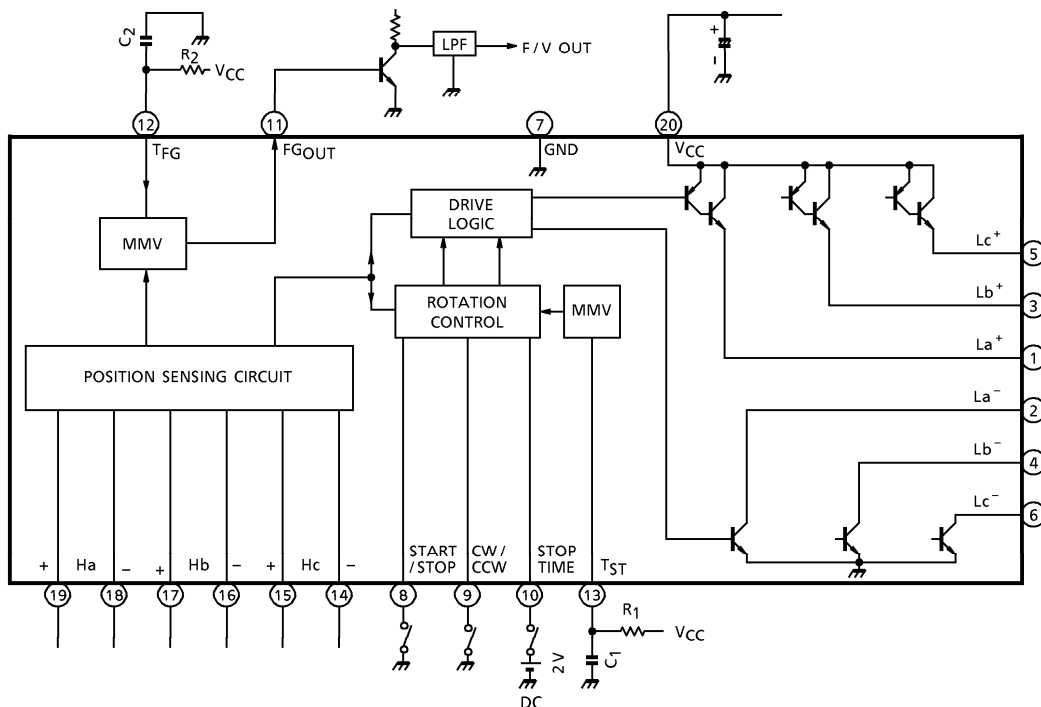

980910EBA2

● TOSHIBA is continually working to improve the quality and the reliability of its products. Nevertheless, semiconductor devices in general can malfunction or fail due to their inherent electrical sensitivity and vulnerability to physical stress. It is the responsibility of the buyer, when utilizing TOSHIBA products, to observe standards of safety, and to avoid situations in which a malfunction or failure of a TOSHIBA product could cause loss of human life, bodily injury or damage to property. In developing your designs, please ensure that TOSHIBA products are used within specified operating ranges as set forth in the most recent products specifications. Also, please keep in mind the precautions and conditions set forth in the TOSHIBA Semiconductor Reliability Handbook.

## PIN FUNCTION

PIN No.	SYMBOL	FUNCTIONAL DESCRIPTION
1	La <sup>+</sup>	a-phase upper drive output terminal
2	La <sup>-</sup>	a-phase lower drive output terminal
3	Lb <sup>+</sup>	b-phase upper drive output terminal
4	Lb <sup>-</sup>	b-phase lower drive output terminal
5	Lc <sup>+</sup>	c-phase upper drive output terminal
6	Lc <sup>-</sup>	c-phase lower drive output terminal
7	GND	GND terminal
8	START/STOP	Start/stop switch terminal
9	CW/CCW	Normal rotation/reverse rotation switch terminal
10	STOP TIME	MMV Time constant switch terminal for stopping
11	FG <sub>OUT</sub>	FG signal output terminal (determines MMV pulse width)
12	T <sub>FG</sub>	C, R connection terminal (determines MMV pulse width)
13	T <sub>ST</sub>	C, R connection terminal (determines MMV time constant for stopping)
14	Hc <sup>-</sup>	c-phase Hall Amp. negative input terminal
15	Hc <sup>+</sup>	c-phase Hall Amp. positive input terminal
16	Hb <sup>-</sup>	b-phase Hall Amp. negative input terminal
17	Hb <sup>+</sup>	b-phase Hall Amp. positive input terminal
18	Ha <sup>-</sup>	a-phase Hall Amp. negative input terminal
19	Ha <sup>+</sup>	a-phase Hall Amp. positive input terminal
20	V <sub>CC</sub>	Power supply input terminal

980910EBA2'

- The products described in this document are subject to the foreign exchange and foreign trade laws.
- The information contained herein is presented only as a guide for the applications of our products. No responsibility is assumed by TOSHIBA CORPORATION for any infringements of intellectual property or other rights of the third parties which may result from its use. No license is granted by implication or otherwise under any intellectual property or other rights of TOSHIBA CORPORATION or others.
- The information contained herein is subject to change without notice.

**TIMING CHART**

Forward rotation (Position sensing signal advances Ha → Hb → Hc)

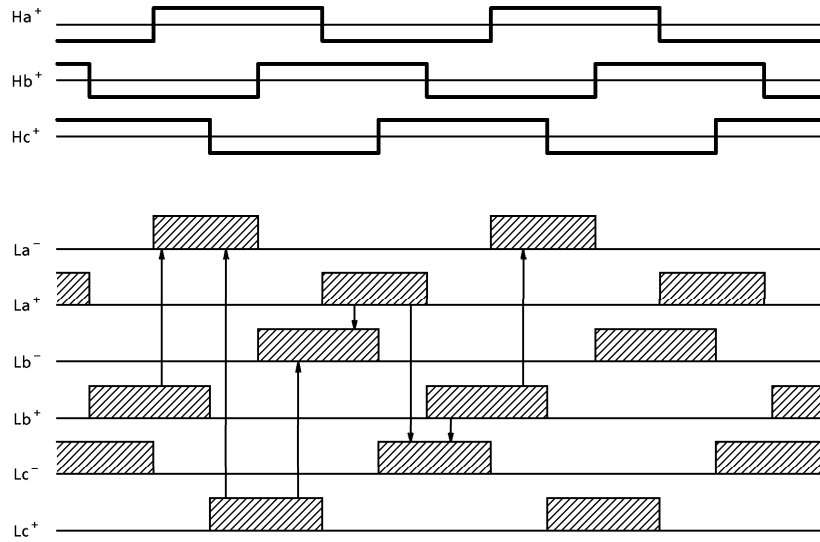

Reverse rotation (Position sensing signal advances Ha → Hc → Hb)

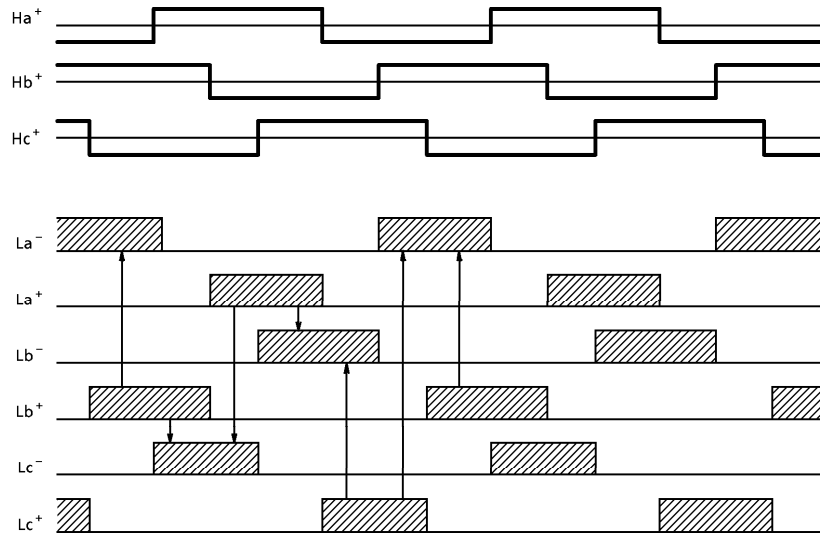

**APPLICATION OF TA7713P**

Like a video disk player, TA7713P is provided with the stopping function which, in a short time, stops the motor having a large inertia, and makes the quick disk-change possible.

To make the frequency generator (FG) unnecessary which was formerly required for fetching the rotation signal, the signal from the position sensing input is ORed and is output to FG output pin (pin ⑪).

Therefore, for FG output, three position sensing outputs (Ha, Hb, Hc) are ORed, and the rotation speed signal of the frequency of six times that of one output can be fetched resulting in making it possible to obtain a sufficient controlling characteristic with the F/V (Frequency-Voltage) conversion method of monostable type.

Description is made on the application of TA7713P in the following.

**(1) Operation of FG output (pin ⑪) and T<sub>FG</sub> (pin ⑫)**

In Fig.1, Q1 and Q2 are the monostable multivibrator to which gate (Q2 base) the signal from each position signal input of Ha, Hb and Hc is input after ORed and shaped in waveform by FF.

The pulse width of MMV made by Q1 and Q2 is determined by R<sub>2</sub> and C<sub>2</sub> to be connected to T<sub>FG</sub> (pin ⑫) and the square wave having the pulse width to be determined by C<sub>2</sub> and R<sub>2</sub> is output. Of course, this frequency is proportional to the rotation speed signal and this frequency is six times the frequency of each position sensing. (6 per 1 electrical rotation.)

F/V conversion operation is made through connecting this FG<sub>0</sub> output to LPF for integration. And if R<sub>2</sub> is made variable, the conversion gain can be changed.

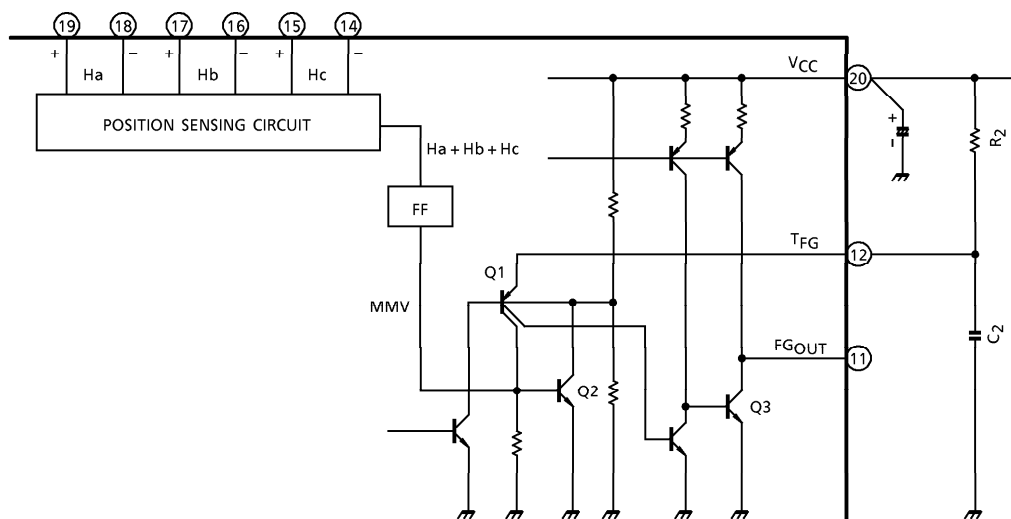

Fig.1

## (2) Stopping function

For stopping the motor, it is the simplest way to stop the inertia through the friction after turning off the motor driving power supply.

However, since too much time is required for stopping the motor having a large inertia, this method is not suitable to the video disk or audio disk player which requires the disk changed in a short time.

In this case, the motor is changed over to the reverse torque state at the same with the input of the stop signal, and the brake is applied keeping the state of normal rotation with reverse torque as an usual method.

In this method, however, reverse runaway is liable to occur unless the reduction of rotation is detected through a certain measure to stop the reverse torque state at an appropriate time. (For example, PLL motor controller TC9142AP is provided with the circuit by which the reverse rotation signal is output at the same time with the stop signal input, and the reduction of rotation speed in this reverse torque state is detected by FG signal to disconnect the reverse rotation signal when the rotation speed reduced down to 1/8 the initial speed.)

In case of the motor of high rotation speed and large inertia like the motor for video disk, to perform the quick braking operation, it is necessary to keep this condition of the forward rotation with reverse torque until just before the motor stops in order to reduce the inertia stopping time to the minimum through the friction force.

For this purpose, in TA7713P, the state of forward rotation with reverse torque is kept continued until the motor stops and either of three position sensing signals detects the reverse rotation with the built-in reverse sensing circuit.

(In case of application of TA7713P, there is no problem in the optical system, however, it is of course necessary to put the sensor apart from the disk at the same time with the stop signal input or before the reverse rotation start in VHD CED system.)

At this time, the state of the reverse rotation is max. 60° in electrical angle.

Furthermore, in order to remove the inertia due to this reverse rotation, the inside monostable multi-vibrator generates the time normal torque determined by the state of C<sub>2</sub>, R<sub>2</sub> and pin<sup>Ⓜ</sup> to turn out the inertia-stopped state afterwards.

By means of these functions, the motor can be stopped in 5~8 seconds with the optical system of high rotation speed and in 2~3 seconds with VHD CED system.

EACH CONTROL INPUT

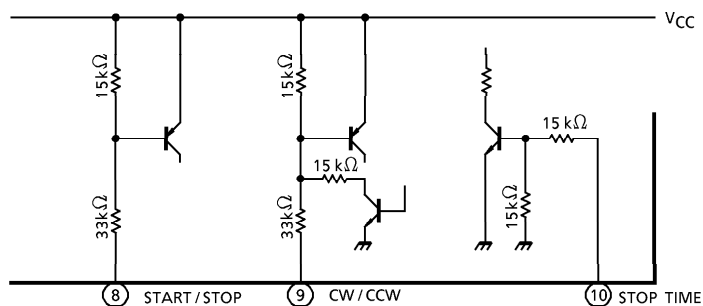

At L, start. At L, normal torque. At H, reverse torque. (Providing, when reverse sensing circuit is "ON", normal torque even at H.) Input which changes the time constant of MMV for stop into two stages (1, 1.6).

Fig.2

PROCEDURE FOR STOP / START

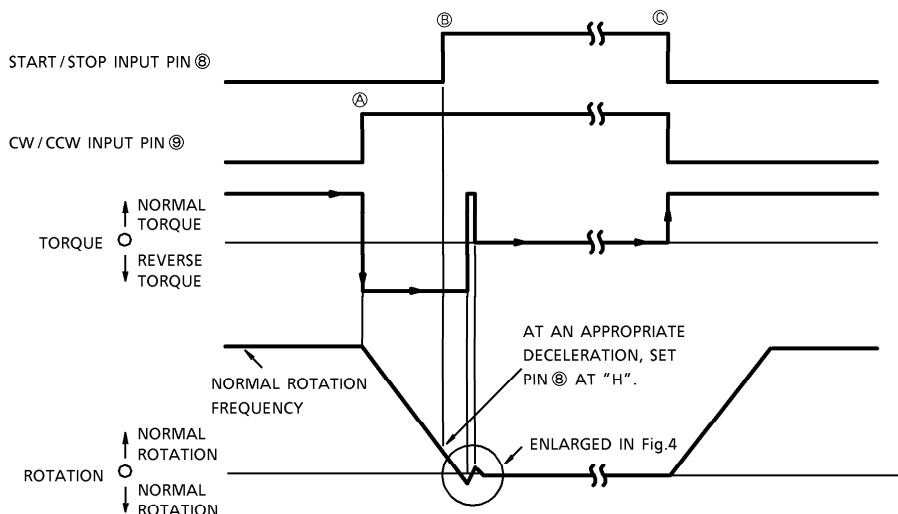

Fig.3

STOP SEQUENCE (Procedure for stopping the system in normal rotation)

1. Set CW / CCW input pin (pin 9) to "H" to make the clockwise mode with reverse torque state. (A point)
2. Detect the reduction of rotation speed due to the reverse torque with FG, etc, and when rotation speed is reduced to 1/3~1/8 normal one, set START / STOP input pin (pin 8) to "H". (B point)
3. By this procedure, the motor stops automatically.  
For starting the system, it is enough to set both START / STOP input and CW / CCW input to "L". (C point)

ENLARGED VIEW OF REVERSE SENSING

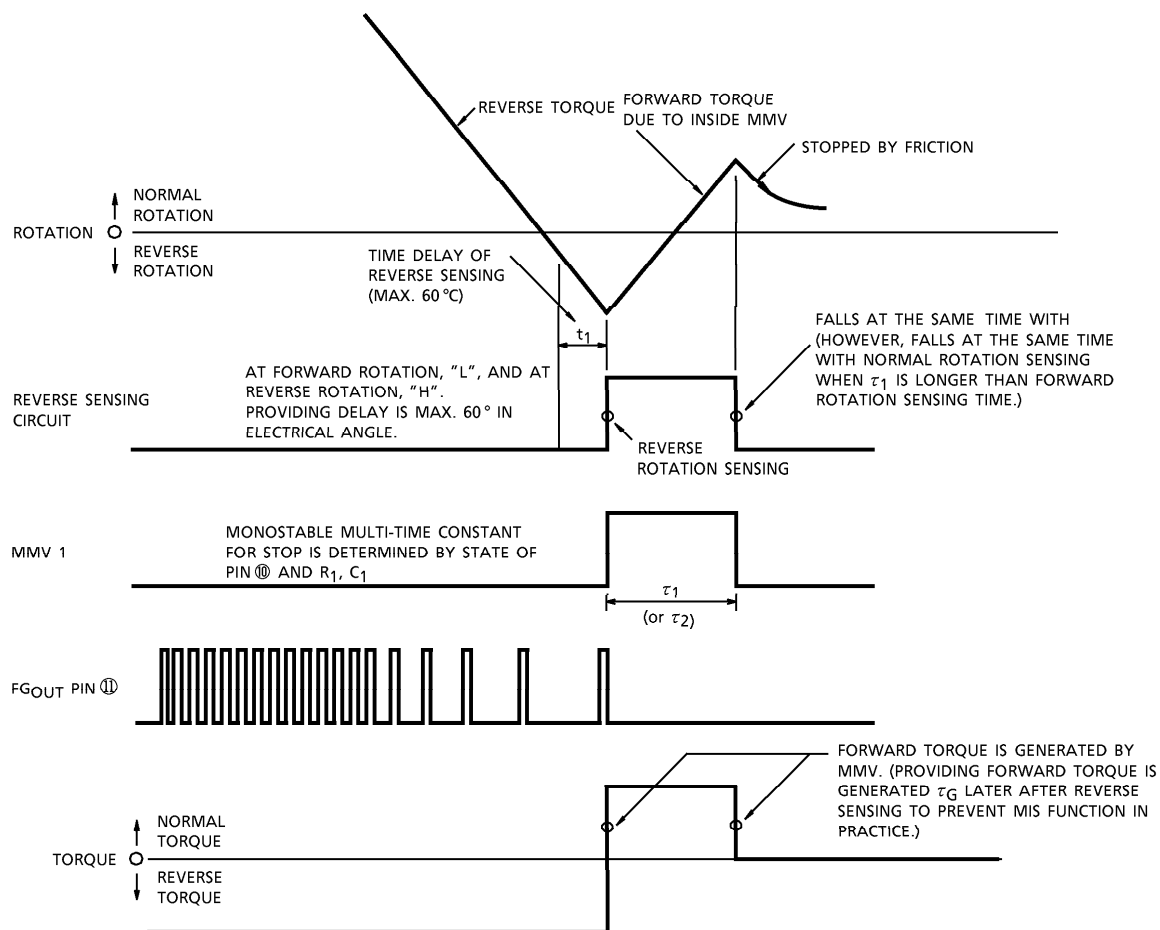

Fig.4

TIMING IN CASE  $\tau_1$  (or  $\tau_2$ ) IS LONGER THAN FORWARD ROTATION SENSING TIME

Fig.5

## (3) Position sensing input circuit

The common mode voltage range of pins ⑭, ⑮, ⑯, ⑰, ⑱ and ⑲ in position sensing input circuit is 2 V to  $V_{CC} - 0.5$  V. Therefore, in case of  $V_{CC} = 5$  V, the range is 2~4.5 V.

Hysteresis of 7 mV (Typ.) is provided at the input to make the operation accurate.

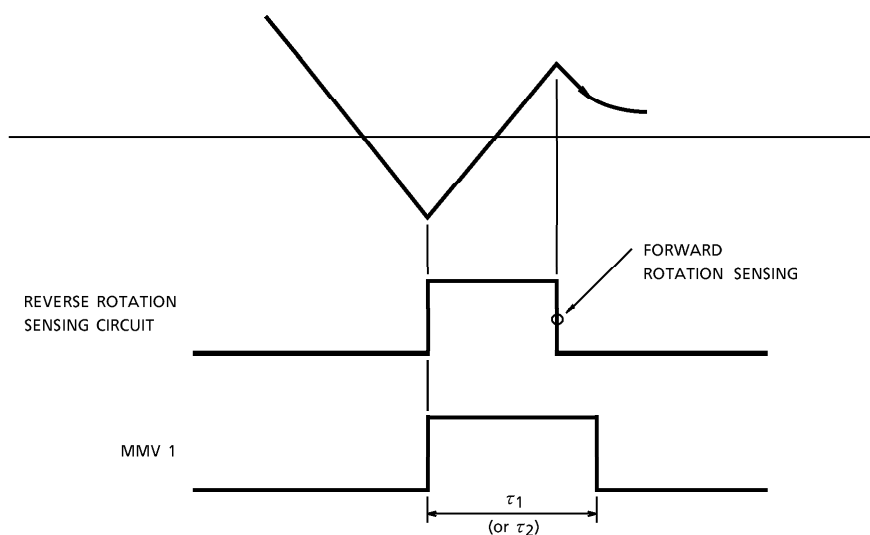
Take care not to allow the hall output exceed the max. voltage 500 mV<sub>p-p</sub> of the position sensing input as shown in maximum rating for caution.

## (4) Output circuit

As shown in the block diagram, in the output circuit, the Darlington emitters of PNP and NPN are of open type on the upper side, and the lower side NPN is the open collector type.

Connect the external transistor in the same manner as that of the application circuit.



## MAXIMUM RATINGS (Ta = 25°C)

CHARACTERISTIC	SYMBOL	RATING	UNIT
Power Supply Voltage	V <sub>CC</sub>	8.0	V
Output Current	I <sub>O</sub>	±25	mA
Position Sensing Circuit Input Voltage (T <sub>j</sub> = 25°C)	V <sub>H</sub>	500	mV <sub>p-p</sub>
Power Dissipation (Ta = 25°C)	P <sub>D</sub> (Note)	1.2	W
Operating Temperature	T <sub>opr</sub>	-30~75	°C
Storage Temperature	T <sub>stg</sub>	-50~125	°C

(Note) No heat sink

ELECTRICAL CHARACTERISTICS (Unless otherwise specified, V<sub>CC</sub> = 5 V, Ta = 25°C)

CHARACTERISTIC		SYMBOL	TEST CIRCUIT	TEST CONDITION	MIN.	TYP.	MAX.	UNIT	
Operating Supply Voltage		V <sub>CC (opr)</sub>	—		4.75	5.00	5.25	V	
Power Supply Current		I <sub>CC1</sub>	1	Stop state	—	3.4	6.0	mA	
		I <sub>CC2</sub>		Output Open	—	17.0	26.0		
Saturation Voltage	Upper Side	V <sub>SAT (U-1)</sub>	2	R <sub>L</sub> = 200 Ω	—	1.3	2.0	V	
		V <sub>SAT (U-2)</sub>		R <sub>L</sub> = 2 kΩ	—	1.0	1.3		
	Lower Side	V <sub>SAT (L-1)</sub>		R <sub>L</sub> = 200 Ω	—	0.8	1.2		
		V <sub>SAT (L-2)</sub>		R <sub>L</sub> = 2 kΩ	—	0.18	0.4		
Leak Current	Upper Side	I <sub>L (U)</sub>	2		—	—	100	μA	
	Lower Side	I <sub>L (L)</sub>			—	—	100		
Position Sensing Input	Common Mode Voltage Range		—		2.0	—	4.5	V	
	Input Sensitivity				V <sub>H</sub>	20	—	—	mV <sub>p-p</sub>
	Input Hysteresis				V <sub>H - Hys</sub>	2	7	15	mV
Start Input (RUN)	Operation Input Voltage	"H"	V <sub>IN R (H)</sub>	2	4.0	—	—	V	
		"L"	V <sub>IN R (L)</sub>	2	—	—	1.0		
	Input Current	"L"	I <sub>IN R</sub>	2	V <sub>IN R</sub> = 1.0 V	—	—	200	μA
CW / CCW Input (FWD / REV)	Operation Input Voltage	"H"	V <sub>IN C (H)</sub>	2	4.0	—	—	V	
		"L"	V <sub>IN C (L)</sub>		—	—	1.0		
	Input Current	"L"	I <sub>IN C</sub>	2	V <sub>IN C</sub> = 1.0 V	—	—	200	μA
Stop-Speed Selection Input (8 / 12)	Operation Input Voltage	"H"	V <sub>IN N (H)</sub>	2	2.0	—	—	V	
		"L"	V <sub>IN N (L)</sub>		—	—	0.5		
	Input Current	"H"	I <sub>IN N</sub>	2	V <sub>IN N</sub> = 1.0 V	—	—	150	μA
FG Output	Output Current	"H"	I <sub>FGH</sub>	3	80	—	—	μA	
	Output Voltage	"L"	V <sub>FG L</sub>	3	I <sub>FG</sub> = 0.3 mA	—	—	0.4	V
	Pulse Width		τ <sub>FG</sub>	3	C = 0.1 μF, R = 10 kΩ	0.9	1.0	1.1	ms
Monostable Multi Vibrator (for stop) Output Pulse Width		τ <sub>1</sub> - 2τ <sub>G</sub>	3	C = 0.1 μF, R = 16 kΩ V <sub>IN N</sub> = 0.5 V	108	120	132	ms	
		τ <sub>2</sub> - 2τ <sub>G</sub>		C = 0.1 μF, R = 16 kΩ V <sub>IN N</sub> = 2.0 V	45	55	61		
		τ <sub>G</sub>			18	23	28		

TEST CIRCUIT 1

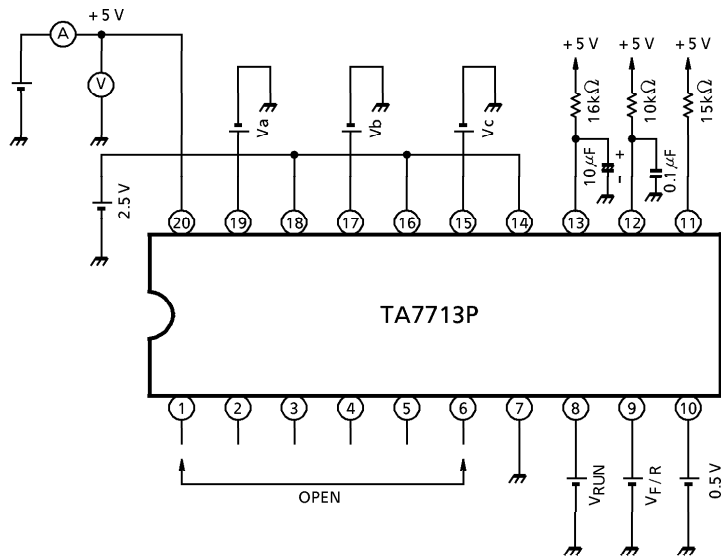

	V <sub>RUN</sub>	V <sub>F/R</sub>	V <sub>a</sub>	V <sub>b</sub>	V <sub>c</sub>	REMARKS
I <sub>CC1</sub>	4.0 V	4.0 V	2.48 V	2.48 V	2.52 V	Reverse sensing must not be made.
I <sub>CC2</sub>	1.0 V	1.0 V	2.52 V	2.48 V	2.52 V	

Measure I<sub>CC1</sub> without fail after setting I<sub>CC2</sub> measuring logic, and carry out the measurement 200 ms after setting I<sub>CC1</sub> measuring logic.

TEST CIRCUIT 2

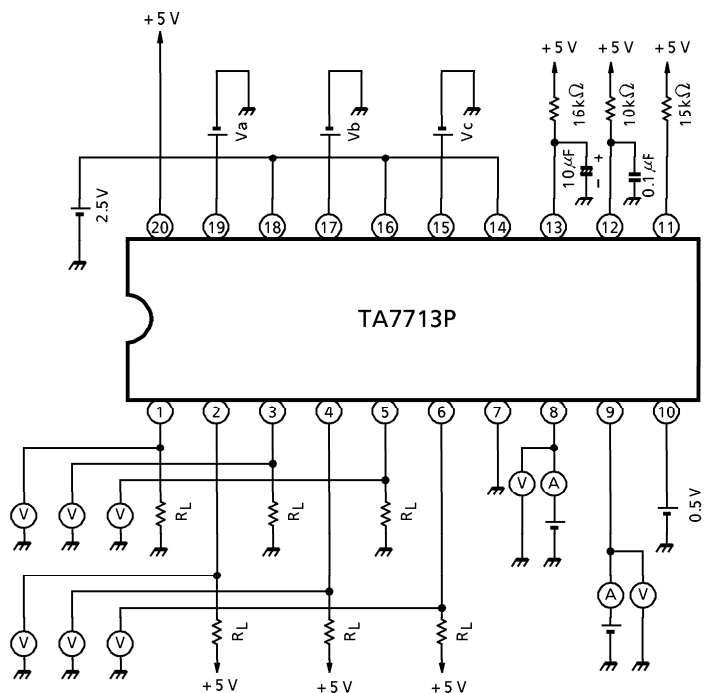

Hall AMP. Input

Check input sensitivity and input hysteresis with  $\pm 20$  mV by means of confirming that leak current and saturation voltage described below can be measured.

INPUT CONDITION					MEASUREMENT ITEM					
Va	Vb	Vc	RUN	F/R	La <sup>+</sup>	La <sup>-</sup>	Lb <sup>+</sup>	Lb <sup>-</sup>	Lc <sup>+</sup>	Lc <sup>-</sup>
2.52 V	2.48 V	2.48 V	V <sub>IN</sub> R (L)	V <sub>IN</sub> C (L)	LEAK	SAT	LEAK	LEAK	SAT	LEAK
2.48 V	2.52 V	2.48 V	—	—	SAT	LEAK	—	SAT	LEAK	—
2.48 V	2.48 V	2.52 V	—	—	—	—	SAT	—	—	SAT

LEAK : Measurement of leak current  
 SAT : Measurement of saturation voltage

TEST CIRCUIT 3

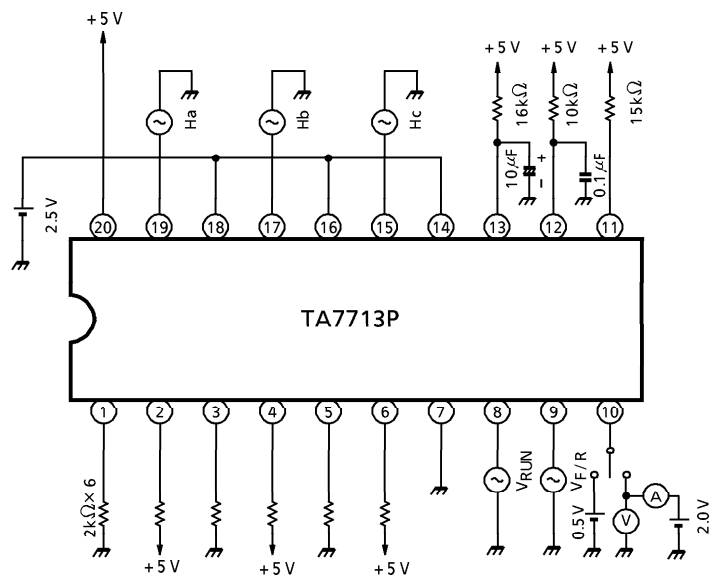

Measurement of  $V_{IN R(H)}$  is determined to be acceptable if  $\tau_1$  and  $\tau_2$  can be measured in the following measurement.

Input Ha, Hb, Hc and  $V_{RUN}$ ,  $V_{F/R}$  made by the oscillator driven with the same clock.

MEASURING METHOD

- $V_{INC(H)}$  When  $V_{F/R}$  varies from 1.0 to 4.0, confirm that  $La^+$  changes from L to H.
- $\tau_1$  Time between fall points of  $La^+$  and  $Lb^+$  when SW1 is set at a.
- $\tau_2$  Time between fall points of  $La^+$  and  $Lb^+$  when SW1 is set at b.
- $I_{INN}$  Read meter at  $\tau_2$  measurement.
- $\tau_G$  Time between fall points of  $La^+$  and  $Lb^+$  when SW1 is set at a.

TEST CIRCUIT 4

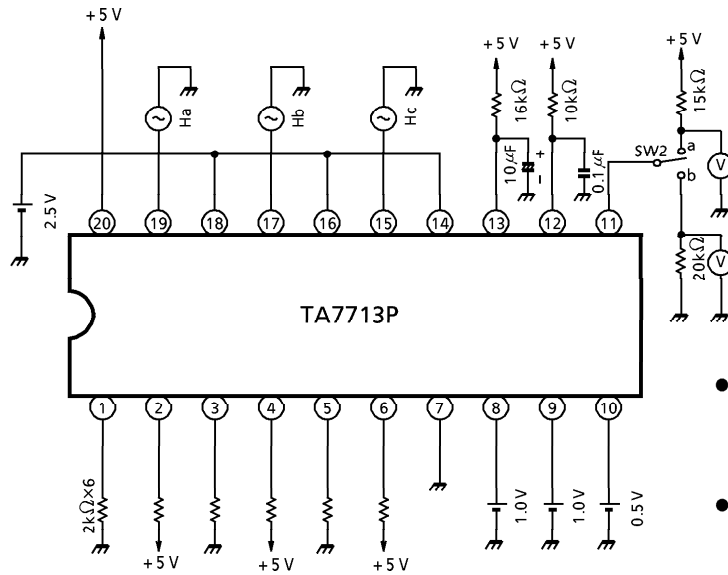

- Measure  $I_{FGH}$  with the voltage obtained when SW2 is set at b.
- Measure  $V_{FGL}$  and  $\tau_{FG}$  when SW2 is set at a.

TIME CHART FOR NORMAL ROTATION

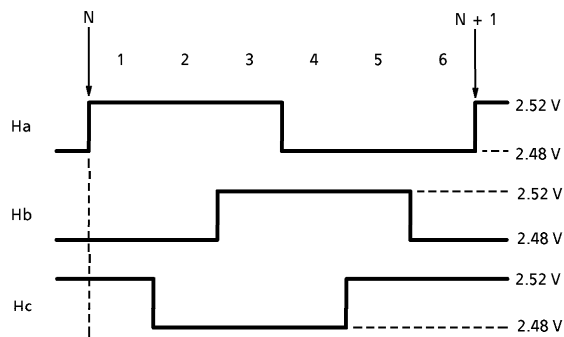

CLOCK 360 Hz

APPLICATION CIRCUIT

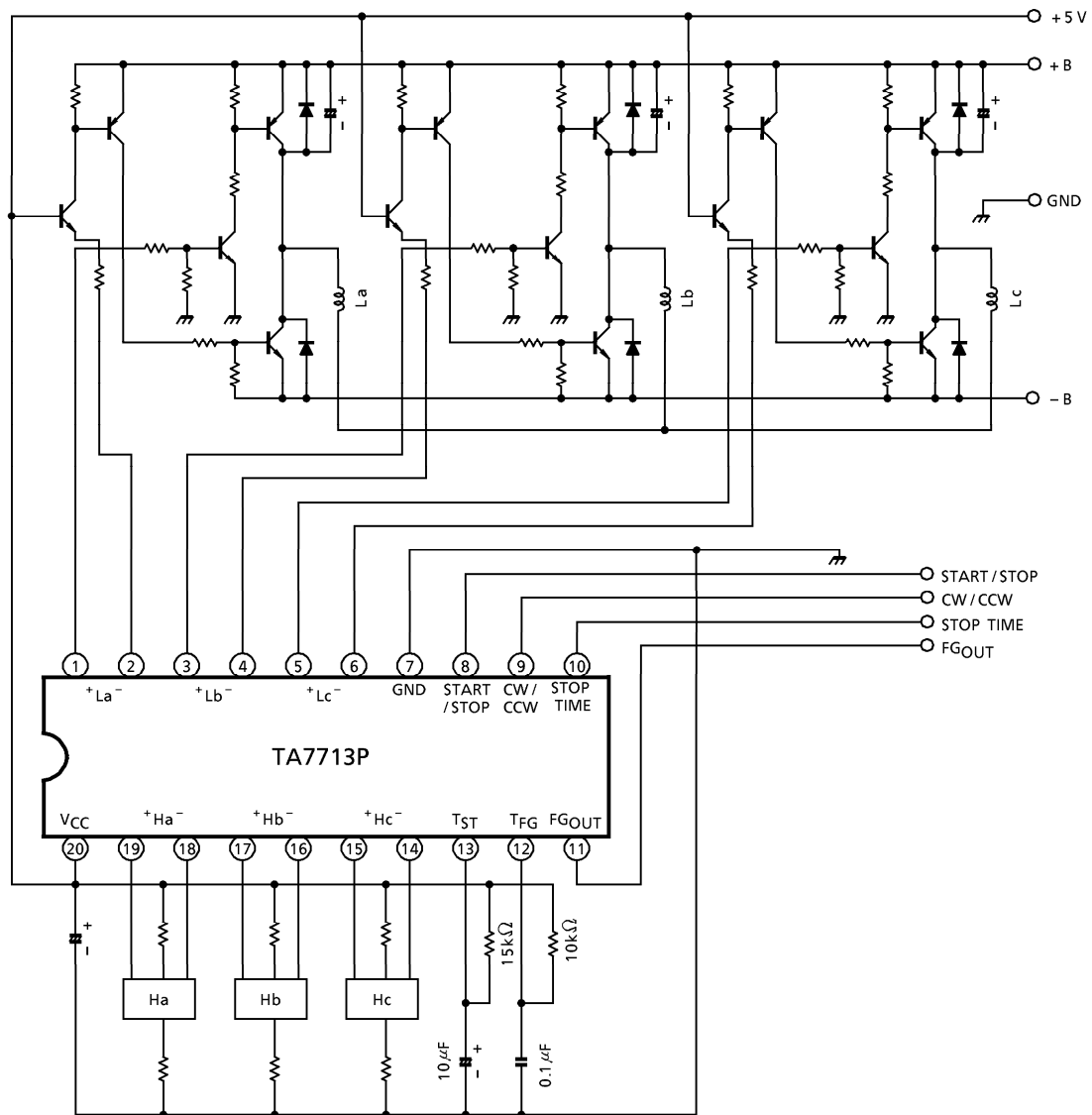

OUTLINE DRAWING  
DIP20-P-300-2.54A

Unit : mm

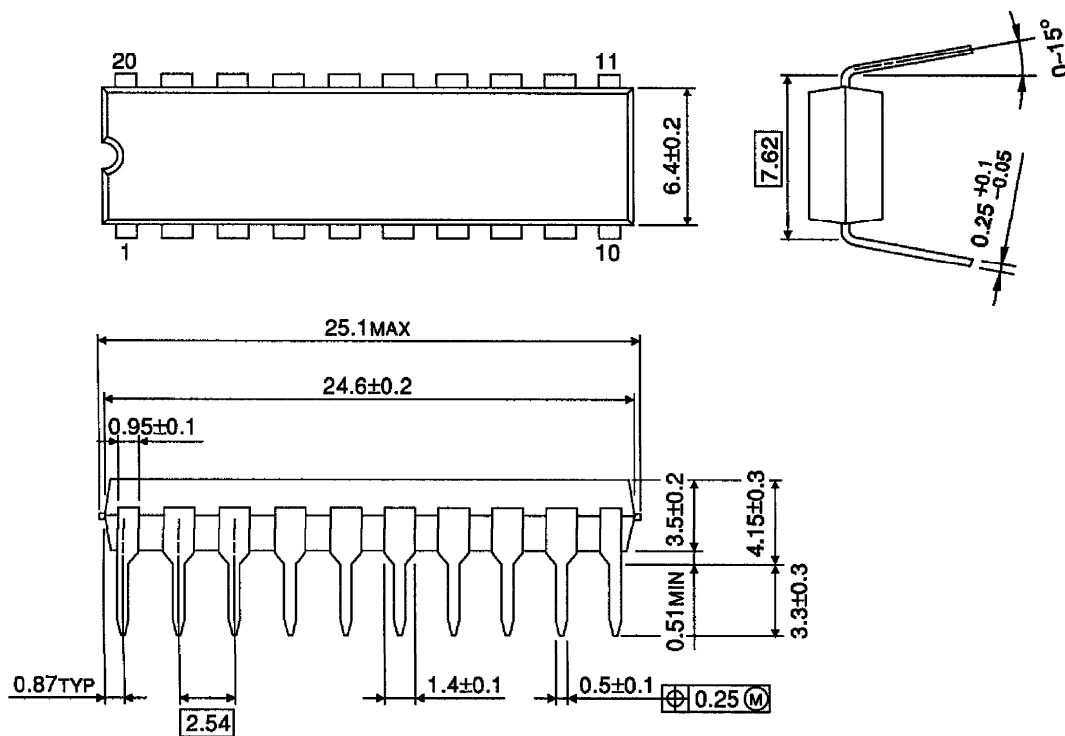

Weight : 2.25 g (Typ.)