

## CMOS 8-Bit Microcontroller

## TMP88CP76F, TMP88CS76F

The TMP88CP76 and TMP88CS76 are the high speed and high performance 8-bit single chip microcomputers. These MCU contain VFT (Vacuum Fluorescent Tube) driver, serial interface, 8-bit AD converter and multi-function timer/counter on a chip.

Part No.	ROM	RAM	Package	OTP version
TMP88CP76F	48K × 8bit + 256 × 8bit	1K × 8-bit	P-QFP80-1420-0.80B	TMP88PS76F
TMP88CS76F	64K × 8bit + 256 × 8bit	2K × 8-bit		

## Features

- ◆ 8-bit single-chip microcomputer TLC5-870/X series microcomputer
- ◆ interrupt sources: 16 (3 external, 13 internal)
- ◆ I/O ports: 68 pins
- ◆ Three 16-bit Timer/Counters
  - TC1: Timer
  - TC2: Timer, Event counter, Window modes
  - ETC1: Timer, Event counter, Window mode
 Minimum resolution: 500  $\mu$ s at 8 MHz  
 Two capture inputs (edge-selectable)  
 One compare outputs  
 (High/Low/Toggle/Steady output modes)
- ◆ 8-bit Timer/Counter
  - TC4: Timer, Event counter, PWM output, Programmable divider output modes
- ◆ Time Base Timer (Interrupt frequency: 1 Hz to 16384 Hz)
- ◆ Divider output function (frequency: 1 kHz to 8 kHz)

P-QFP80-1420-0.80B

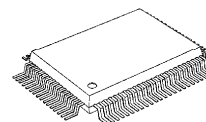

TMP88CP76  
 TMP88CS76  
 TMP88PS76

000707EBA1

- For a discussion of how the reliability of microcontrollers can be predicted, please refer to Section 1.3 of the chapter entitled Quality and Reliability Assurance / Handling Precautions.
- TOSHIBA is continually working to improve the quality and reliability of its products. Nevertheless, semiconductor devices in general can malfunction or fail due to their inherent electrical sensitivity and vulnerability to physical stress. It is the responsibility of the buyer, when utilizing TOSHIBA products, to comply with the standards of safety in making a safe design for the entire system, and to avoid situations in which a malfunction or failure of such TOSHIBA products could cause loss of human life, bodily injury or damage to property. In developing your designs, please ensure that TOSHIBA products are used within specified operating ranges as set forth in the most recent TOSHIBA products specifications. Also, please keep in mind the precautions and conditions set forth in the "Handling Guide for Semiconductor Devices," or "TOSHIBA Semiconductor Reliability Handbook" etc..
- The TOSHIBA products listed in this document are intended for usage in general electronics applications (computer, personal equipment, office equipment, measuring equipment, industrial robotics, domestic appliances, etc.). These TOSHIBA products are neither intended nor warranted for usage in equipment that requires extraordinarily high quality and/or reliability or a malfunction or failure of which may cause loss of human life or bodily injury ("Unintended Usage"). Unintended Usage include atomic energy control instruments, airplane or spaceship instruments, transportation instruments, traffic signal instruments, combustion control instruments, medical instruments, all types of safety devices, etc.. Unintended Usage of TOSHIBA products listed in this document shall be made at the customer's own risk.
- The products described in this document are subject to the foreign exchange and foreign trade laws.
- The information contained herein is presented only as a guide for the applications of our products. No responsibility is assumed by TOSHIBA CORPORATION for any infringements of intellectual property or other rights of the third parties which may result from its use. No license is granted by implication or otherwise under any intellectual property or other rights of TOSHIBA CORPORATION or others.
- The information contained herein is subject to change without notice.



Purchase of TOSHIBA I<sup>2</sup>C components conveys a license under the Philips I<sup>2</sup>C Patent Rights to use these components in an I<sup>2</sup>C system, provided that the system conforms to the I<sup>2</sup>C Standard Specification as defined by Philips.

- ◆ Watchdog Timer
  - Interrupt source/reset output (programmable)
- ◆ 8-bit Serial Interfaces
  - With 8bytes transmits/receive data buffer
  - Internal/external serial clock, and 4/8-bit mode
- ◆ Serial bus Interface
  - I<sup>2</sup>C bus, 8-Bit SIO Modes
- ◆ 8-bit successive approximate type AD converter with sample and hold
  - 12 analog inputs
  - Conversion time: 23  $\mu$ s at 8 MHz
- ◆ Vacuum Fluorescent Tube Driver (automatic display)
  - Programmable grid scan
  - High breakdown voltage ports (max.40 V  $\times$  40 bits)
- ◆ Dual clock operation
  - Single/Dual-clock mode
- ◆ Five Power saving operating modes
  - STOP mode: Oscillation stops. Battery/Capacitor back-up.Port output hold/High-impedance.
  - SLOW mode: Low power consumption operation using low-frequency clock (32.768 kHz)
  - IDLE1 mode: CPU stops, and Peripherals operate using high-frequency clock. Release by interrupts.
  - IDLE2 mode: CPU stops, and Peripherals operate using high-and low-frequency clock. Release by interrupt.
  - SLEEP mode: CPU stops, and Peripherals operate using low-frequency clock. Release by interrupts.
- ◆ Wide operating voltage: 4.5 to 5.5 V at 12.5 MHz / 32.768 kHz, 2.7 to 5.5 V at 32.768 kHz
- ◆ Emulation Pod: BM87CP77F0A

Pin Assignments (Top View)

P-QFP80-1420-0.80B

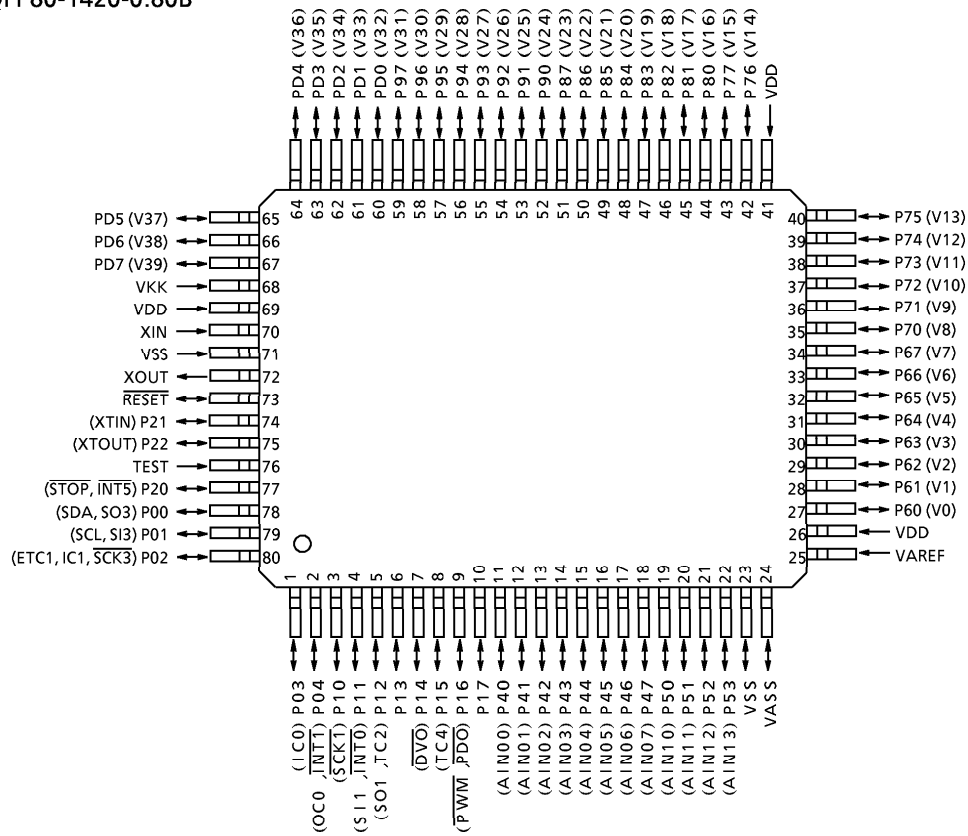

Note: All VDDs should be connected externally for keeping the same voltage level.

Block Diagram

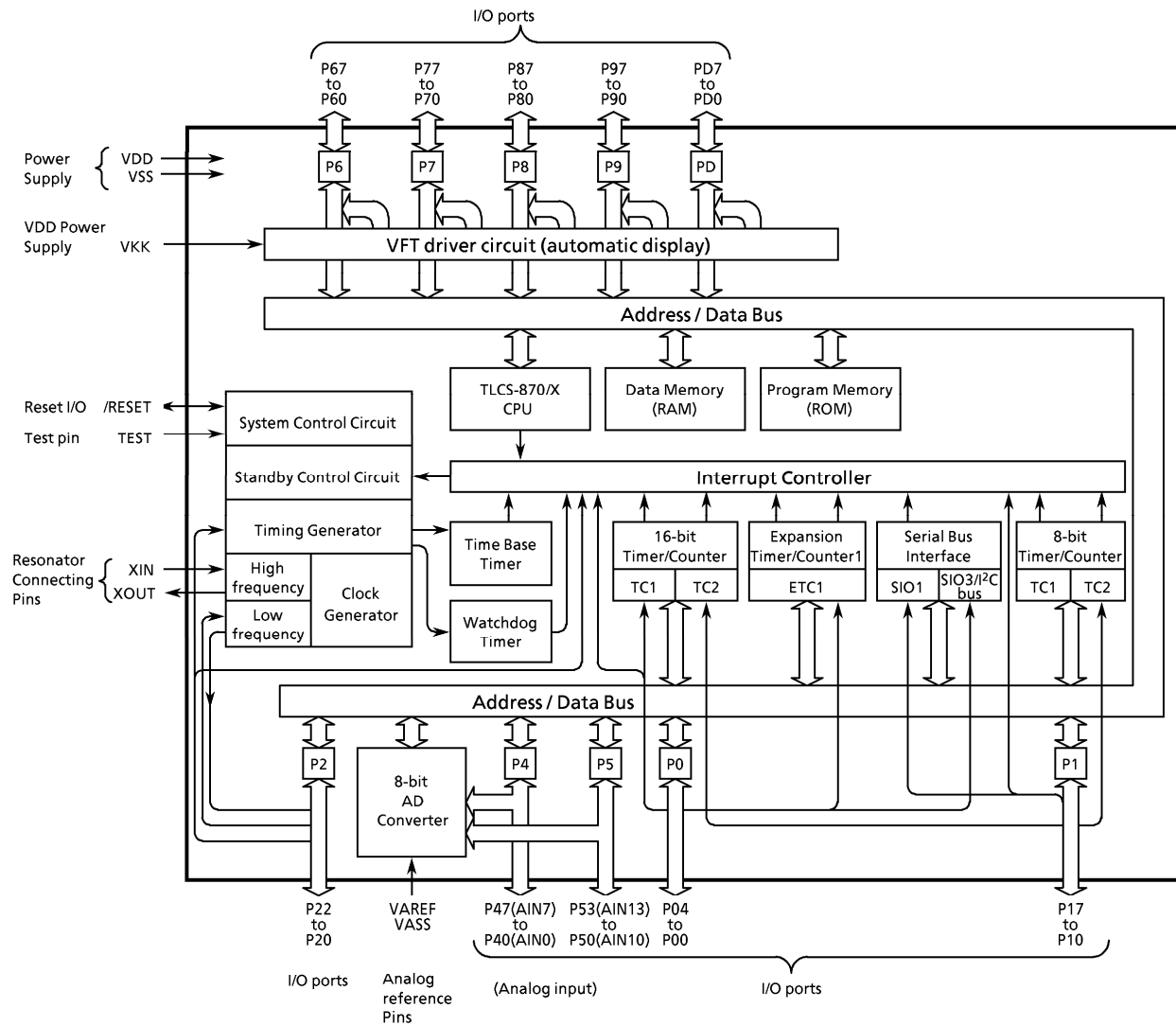

## Pin Function

Pin Name	I/O	Function		
P04 (OC0,INT1)	I/O (I/O)	5-bit input / output port with latch. When used as input port, multi function timer/counter, external interrupt input, serial bus interface, the latch must be set to "1".	Expansion Timer/Counter compare output 0 or External interrupt input 1	
P03 (IC0)	I/O (input)		Expansion Timer/Counter capture input 0	
P02 (IC1,ETC1,SCK3)	I/O (I/O)		Expansion Timer/Counter capture input 1 or Expansion Timer/Counter 1 input or SIO 3 serial clock input/output	
P01 (SCL,S13)	I/O (I/O)		I <sup>2</sup> C bus serial clock input/output or SIO3 serial data input	
P00(SDA,SO3)	I/O (I/O)		I <sup>2</sup> C bus serial data input/output or SIO3 serial data output	
P17	I/O	8-bit programmable input/output ports (tri-state). Each bit of this port can be individually configured as an input or an output under software control. When used as serial interface, external interrupt input, timer/ counter input, the input mode is configured. When used as divider output, timer/ counter output, serial data output, the latch must be set to "1" and the output mode is configured.	8-bit PWM output or 8-bit programmable divider output	
P16 (PWM,PDO)	I/O (output)		Timer/Counter 4 input	
P15 (TC4)	I/O (input)		Divider output	
P14 (DVO)	I/O (output)		SIO1 serial data output or Timer/Counter 2 input	
P13	I/O		SIO1 serial data input or External interrupt 0 input	
P12 (SO1, TC2)	I/O (I/O)		SIO1 serial clock input/output	
P11 (SI1, INT0)	I/O (input)		Resonator connection pins (32.768kHz). For inputting external clock, XTIN is used and XOUT is opened.	
P10 (SCK1)	I/O (I/O)			External interrupt input 5 or STOP mode release signal input
P22 (XTOUT)	I/O (I/O)			AD converter analog inputs
P21 (XTIN)	I/O (input)			
P20 (INT5, STOP)	I/O (input)			
P47 (AIN07) to P40 (AIN00)	I/O (input)	4-bit programmable input/output ports (tri-state). Each bit of this port can be individually configured as an input or an output under software control. When used as analog input, the input mode is configured.	AD converter analog inputs	
P53 (AIN13) to P50 (AIN10)	I/O (input)			
P67 (V7) to P60 (V0)	I/O (output)	Six 8-bit high breakdown voltage output ports with the latch. When used as a VFT driver output, the latch must be cleared to "0".	VFT driver output	
P77 (V15) to P70 (V8)	I/O (output)			
P87 (V23) to P80 (V16)	I/O (output)			
P97 (V31) to P90 (V24)	I/O (output)			
PD7 (V39) to PD0 (V31)	I/O (output)			
XIN,XOUT	Input, output	Resonator connecting pins for high-frequency clock. For inputting external clock, XIN is used and XOUT is opened.		
RESET	I/O	Reset signal input or watchdog timer output/address-trap-reset output /sistem-clock-reset output.		
TEST	Input	Test pin for out-going test.Be tied to low.		
VDD,VSS (Note)	Power Supply	+ 5 V, 0 V (GND)		
VKK		VFT driver power supply		
VAREF,VASS		Analog reference voltae inputs (High, Low)		

Note: All VDDs should be connected externally for keeping the same voltage level.

## Operational Description

### 1. CPU Core Functions

The CPU core consists of a CPU, a system clock controller, an interrupt controller, and a watchdog timer. This section provides a description of the CPU core, the program memory (ROM), the data memory (RAM), and the reset circuit.

#### 1.1 Memory Address Map

TLCS-870/X Series, the memory is organized 4 address spaces (ROM, RAM, SFR, and DBR). Figure 1-1 shows the memory address maps of the TMP88CP76/S76. It uses a memory mapped I/O system, and all I/O registers are mapped in the SFR/DBR address spaces. There are 16 banks of general-purpose registers.

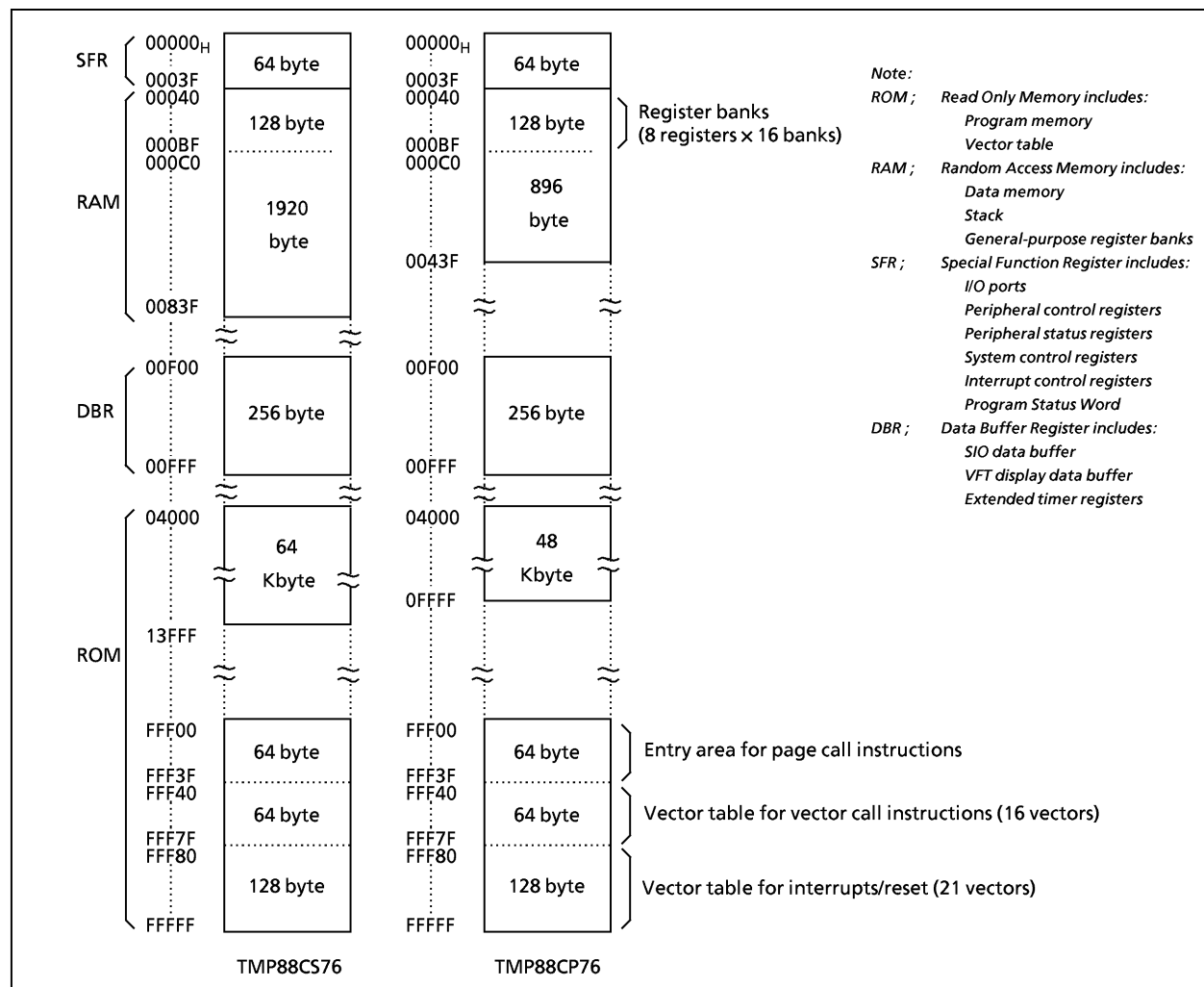

Figure 1-1. Memory Address Maps

#### 1.2 Program Memory (ROM)

The TMP88CP76 has a 48 Kbytes (addresses 04000<sub>H</sub> to 0FFFF<sub>H</sub>) and 256 bytes (addresses FFF00<sub>H</sub> to FFFF<sub>H</sub>), the TMP88CS76 has a 64 Kbytes (address 04000<sub>H</sub> to 13FFF<sub>H</sub>) and 256 bytes (addresses FFF00<sub>H</sub> to FFFF<sub>H</sub>) of program memory (mask programmed ROM). Figure 1-1 shown in Memory address maps. Addresses FFF00<sub>H</sub> to FFFF<sub>H</sub> in the program memory can also be used for special purposes.

## Electrical Characteristics

Absolute Maximum Ratings		(V <sub>SS</sub> = 0 V)		
Parameter	Symbol	Pins	Ratings	Unit
Supply Voltage	V <sub>DD</sub>		- 0.3 to 6.5	V
Input Voltage	V <sub>IN1</sub>	P1, P2, P4, P5, XOUT, $\overline{\text{RESET}}$	- 0.3 to V <sub>DD</sub> + 0.3	V
	V <sub>IN2</sub>	P0 port	- 0.3 to 5.5 V	
Output Voltage	V <sub>OUT1</sub>	P1, P2, P4, P5, XOUT, $\overline{\text{RESET}}$	- 0.3 to V <sub>DD</sub> + 0.3	V
	V <sub>OUT2</sub>	P0 port	- 0.3 to 5.5 V	
	V <sub>OUT3</sub>	Source open drain ports	V <sub>DD</sub> - 40 to V <sub>DD</sub> + 0.3	
Output Current (Per 1 pin)	I <sub>OUT1</sub>	P0, P1, P2, P4, P5 ports	3.2	mA
	I <sub>OUT2</sub>	P6, P7, P8, 81 Ports	- 25	
	I <sub>OUT3</sub>	P82 to P87, P9, PD ports	- 12	
Output Current (Total)	$\Sigma$ I <sub>OUT1</sub>	P1, P4, P5 ports	- 40	mA
	$\Sigma$ I <sub>OUT2</sub>	P0, P1, P2, P4, P5 ports	60	
	$\Sigma$ I <sub>OUT3</sub>	P6, P7, P8, P9, PD ports	- 120	
Power Dissipation [T <sub>opr</sub> = 25°C]	PD Note2		1200	mW
Soldering Temperature (time)	T <sub>sld</sub>		260 (10 s)	°C
Storage Temperature	T <sub>stg</sub>		- 55 to + 125	°C
Operating Temperature	T <sub>opr</sub>		- 30 to + 70	°C

**Note 1:** The absolute maximum ratings are rated values which must not be exceeded during operation, even for an instant. Any one of the ratings must not be exceeded. If any absolute maximum rating is exceeded, a device may break down or its performance may be degraded, causing it to catch fire or explode resulting in injury to the user. Thus, when designing products which include this device, ensure that no absolute maximum rating value will ever be exceeded.

**Note 2:** Power Dissipation (PD) ; For PD, it is necessary to decrease -14.3 mW/°C.

**Note 3:** All VDDs should be connected externally for keeping the same voltage level.

Recommended Operating Conditions		(V <sub>SS</sub> = 0 V, T <sub>opr</sub> = - 30 to 70°C)				
Parameter	Symbol	Pins	Conditions	Min	Max	Unit
Supply Voltage	V <sub>DD</sub>		fc =	4.5	5.5	V
			12.5 MHz			
			fs =	SLOW mode		
				32.768 kHz	SLEEP mode	
		STOP mode	2.0			
Input High Voltage	V <sub>IH1</sub>	Except hysteresis input	V <sub>DD</sub> ≥ 4.5 V	V <sub>DD</sub> × 0.70	V <sub>DD</sub>	V
	V <sub>IH2</sub>	Hysteresis input		V <sub>DD</sub> × 0.75		
	V <sub>IH3</sub>		V <sub>DD</sub> < 4.5 V	V <sub>DD</sub> × 0.90		
Input Low Voltage	V <sub>IL1</sub>	Except hysteresis input	V <sub>DD</sub> ≥ 4.5 V	V <sub>DD</sub> × 0.30	V	V
	V <sub>IL2</sub>	Hysteresis input		V <sub>DD</sub> × 0.25		
	V <sub>IL3</sub>		V <sub>DD</sub> < 4.5 V	V <sub>DD</sub> × 0.10		
Clock Frequency	fc	XIN, XOUT	V <sub>DD</sub> = 4.5 V to 5.5 V	1.0	12.5	MHz
	fs	XTIN, XTOUT	V <sub>DD</sub> = 2.7 V to 5.5 V	30.0	34.0	kHz

**Note:** The recommended operating conditions for a device are operating conditions under which it can be guaranteed that the device will operate as specified. If the device is used under operating conditions other than the recommended operating conditions (supply voltage, operating temperature range, specified AC/DC values etc.), malfunction may occur. Thus, when designing products which include this device, ensure that the recommended operating conditions for the device are always adhered to.

## How to calculate power consumption.

With the TMP88CP76/S76, a pull-down resistor ( $R_k = 80 \text{ k}\Omega$  typ.) can be built into a VFT driver using mask option (port by port). The share of VFT driver loss (VFT driver output loss + pull-down resistor ( $R_k$ ) loss) in power consumption  $P_{\text{max}}$  is high. When using a fluorescent display tube with a large number of segments, the maximum power consumption  $P_d$  must not be exceeded.

power consumption  $P_{\text{max}} = \text{operating power consumption} + \text{normal output port loss} + \text{VFT driver loss}$

Where,

operating power consumption:  $V_{\text{DD}} \times I_{\text{DD}}$

normal power consumption:  $\sum I_{\text{out}2} \times 0.4$

VFT driver loss: VFT driver output loss + pull-down resistor ( $R_k$ ) loss

Example:

When  $T_a = 10$  to  $50^\circ\text{C}$  and a fluorescent display tube with segment output = 3 mA, digit output = 15 mA,  $V_{\text{xx}} = -25 \text{ V}$  is used.

Operating conditions:  $V_{\text{DD}} = 5 \text{ V} \pm 10\%$ ,  $f_c = 8 \text{ MHz}$ , VFT dimmer time (DIM) =  $(14/16) \times t_{\text{seg}}$ :

Power consumption  $P_{\text{max}} = (1) + (2) + (3)$

Where, segments pin = X grid pin = Y, Y = 2

(1) Operating power consumption:  $V_{\text{DD}} \times I_{\text{DD}} = 5.5 \text{ V} \times 22 \text{ mA} = 121 \text{ mW}$

(2) Normal output port loss:  $\sum I_{\text{out}2} \times 0.4 \text{ V} = 60 \text{ mA} \times 0.4 \text{ V} = 24 \text{ mW}$

(3) VFT driver loss: segment pin =  $3 \text{ mA} \times 2 \text{ V} \times \text{number of segments } X = 6 \text{ mW} \times X$   
 digit pin =  $15 \text{ mA} \times 2 \text{ V} \times 14/16 \text{ (DIM)} \times \text{number of grids } Y$   
 = 52.5 mW

$R_k$  loss =  $(5.5 + 25 \text{ V})^2 / 50 \text{ k}\Omega \times (\text{number of segments } X + \text{number of digits } Y) =$   
 $18.605 \text{ mW} \times (X + 2)$

Therefore,  $P_{\text{max}} = 121 \text{ mW} + 24 \text{ mW} + 6 \text{ mW} \times X + 52.5 \text{ mW} + 18.605 \text{ mW} \times (X + 2) = 234.71 + 24.605X$

Maximum power consumption  $P_d$  when  $T_a = 50^\circ\text{C}$  is determined by the following equation:

$P_D = 1200 \text{ mW} - (14.3 \times 25) = 842.5 \text{ mW}$

The number of segments X which can be lit is:

$P_D > P_{\text{max}}$

$842.5 \text{ mW} > 234.71 \text{ mW} + 24.605 X$

$24.7 > X$

Thus, a fluorescent display tube with less than 24 segments can be used. If a fluorescent display tube with 24 segments or more is used, either a pull-down resistor must be attached externally, or the number of segments to be lit must be kept to less than 24 by software.



## D.C. Characteristics

 $(V_{SS} = 0\text{ V}, T_{opr} = -30\text{ to }70^{\circ}\text{C})$ 

Parameter	Symbol	Pins	Conditions	Min	Typ.	Max	Unit
Hysteresis Voltage	$V_{HS}$	Hysteresis input		–	0.9	–	V
Input Current	$I_{IN1}$	TEST	$V_{DD} = 5.5\text{ V}$ $V_{IN} = 5.5\text{ V} / 0\text{ V}$	–	–	$\pm 2$	$\mu\text{A}$
	$I_{IN2}$	Open drain ports, Tri-state ports					
	$I_{IN3}$	RESET, STOP					
Input Resistance	$R_{IN2}$	RESET		100	220	450	$\text{k}\Omega$
Pull-down Resistance	$R_K$	Source open drain ports	$V_{DD} = 5.5\text{ V}, V_{KK} = -30\text{ V}$	50	80	110	
Output Leakage Current	$I_{LO1}$	Sink open drain ports	$V_{DD} = 5.5\text{ V}, V_{OUT} = 5.5\text{ V}$	–	–	2	$\mu\text{A}$
	$I_{LO2}$	Source open drain ports	$V_{DD} = 5.5\text{ V}, V_{OUT} = -32\text{ V}$	–	–	–2	
	$I_{LO3}$	Tri-state ports	$V_{DD} = 5.5\text{ V}, V_{OUT} = 5.5\text{ V} / 0\text{ V}$	–	–	2	
Output High Voltage	$V_{OH2}$	Tri-state ports	$V_{DD} = 4.5\text{ V}, I_{OH} = -0.7\text{ mA}$	4.1	–	–	V
Output Low Voltage	$V_{OL}$	Except XOUT	$V_{DD} = 4.5\text{ V}, I_{OL} = 1.6\text{ mA}$	–	–	0.4	V
Output High current	$I_{OH1}$	P6, P7, P80, P81 ports	$V_{DD} = 4.5\text{ V}, V_{OH} = 2.4\text{ V}$	–	–30	–	mA
	$I_{OH2}$	P82 to P87, P9, PD ports		–	–15	–	
Supply Current in NORMAL 1, 2 modes	$I_{DD}$		$V_{DD} = 5.5\text{ V}$ $V_{IN} = 5.3\text{ V} / 0.2\text{ V}$ $f_c = 12.5\text{ MHz}$ $f_s = 32.768\text{ kHz}$	–	15	22	mA
Supply Current in IDLE 1, 2 modes				–	6	12	
Supply Current in SLOW mode				–	30	60	$\mu\text{A}$
Supply Current in SLEEP mode				–	15	30	
Supply Current in STOP mode				–	0.5	10	

Note 1: Typical values show those at  $T_{opr} = 25^{\circ}\text{C}$ ,  $V_{DD} = 5.0\text{ V}$ .

Note 2: Input Current  $I_{IN1}, I_{IN3}$ ; The current through resistor is not included, when the input resistor (pull-up/pull-down) is contained.

## AD Conversion Characteristics

 $(V_{SS} = 0\text{ V}, V_{DD} = 4.5\text{ to }5.5\text{ V}, T_{opr} = -30\text{ to }70^{\circ}\text{C})$ 

Parameter	Symbol	Conditions	Min	Typ.	Max	Unit
Analog Reference Voltage	$V_{AREF}$		4.5	–	$V_{DD}$	V
	$V_{ASS}$		$V_{SS}$			
Analog Input Voltage	$V_{AIN}$		$V_{ASS}$	–	$V_{AREF}$	V
Analog Supply Current	$I_{REF}$	$V_{AREF} = 5.5\text{ V}, V_{ASS} = 0.0\text{ V}$	–	0.5	1.0	mA
Nonlinearity Error		$V_{DD} = 5.0\text{ V}, V_{SS} = 0.0\text{ V}$ $V_{AREF} = 5.000\text{ V}$ $V_{ASS} = 0.000\text{ V}$	–	–	$\pm 1$	LSB
Zero Point Error			–	–	$\pm 1$	
Full Scale Error			–	–	$\pm 1$	
Total Error			–	–	$\pm 2$	

Note: Total errors includes all errors, except quantization error.

A.C. Characteristics		(V <sub>SS</sub> = 0 V, V <sub>DD</sub> = 4.5 to 5.5 V, Topr = - 30 to 70°C)				
Parameter	Symbol	Conditions	Min	Typ.	Max	Unit
Machine Cycle Time	t <sub>cy</sub>	In NORMAL1, 2 modes	0.32	-	10	μs
		In IDLE 1, 2 modes				
		In SLOW mode	117.6	-	133.3	
		In SLEEP mode				
High Level Clock Pulse Width	t <sub>WCH</sub>	For external clock operation (XIN input), f <sub>c</sub> = 12.5 MHz	32	-	-	ns
Low Level Clock Pulse Width	t <sub>WCL</sub>					
High Level Clock Pulse Width	t <sub>WSH</sub>	For external clock operation (XTIN input), f <sub>s</sub> = 32.768 kHz	15.2	-	-	μs
Low Level Clock Pulse Width	t <sub>WSL</sub>					

Recommended Oscillating Conditions		(V <sub>SS</sub> = 0 V, V <sub>DD</sub> = 4.5 to 5.5 V, Topr = - 30 to 70°C)				
Parameter	Oscillator	Oscillation Frequency	Recommended Oscillator		Recommended Constant	
					C <sub>1</sub>	C <sub>2</sub>
High-frequency Oscillation	Ceramic Resonator	12.5 MHz	Murata	CSA12.5MTZ	30 pF	30 pF
		8 MHz	Murata	CSA8.00MTZ	30 pF	30 pF
	Crystal Oscillator	12.5 MHz	NDK	AT-51	10 pF	10 pF
Low-frequency Oscillation	Crystal Oscillator	32.768 kHz	NDK	MX-38T	15 pF	15 pF

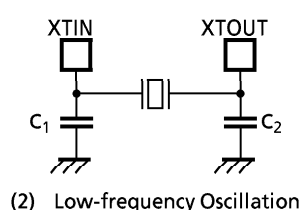
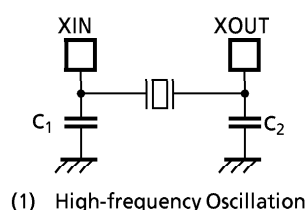

**Note:** An electrical shield by metal shield plate on the surface of IC package should be recommendable in order to prevent the device from the high electric fieldstress applied from CRT (Cathode Ray Tube) for continuous reliable operation.

Typical Characteristics

(Ta = 25°C)

