

TOSHIBA

1999-9-17

TOSHIBA Original CMOS 8-bit Microcontroller

TLCS-870/C Series

TMP86C829U/F, TMP86CH29U/F, TMP86CM29U/F, TMP86PM29U/F

Databook

10th Edition

TOSHIBA CORPORATION

CMOS 8-Bit Microcontroller

TMP86C829U/F, TMP86CH29U/F, TMP86CM29U/F

The 86C829/H29/M29 are the high-speed, high-performance and low power consumption 8-bit microcomputer, including large-capacity ROM, RAM, LCD driver, multi-function timer / counter, serial interface (UART/SIO), a 10-bit A/D converter and two clock generators on chip.

Part No.	ROM	RAM	Package	OTP MCU
TMP86C829U/F	8 K × 8-bit	512 × 8 bit	P-LQFP64-1010-0.50	TMP86PM29U/F
TMP86CH29U/F	16 K × 8-bit	1.5 K × 8 bit	P-QFP64-1414-0.80A	
TMP86CM29U/F	32 K × 8-bit			

Features

- ◆ 8-bit single chip microcomputer TLCS-870/C series
- ◆ Instruction execution time: 0.25 μ s (at 16 MHz)
122 μ s (at 32.768 kHz)
- ◆ 132 types & 731 basic instructions
- ◆ 18 interrupt sources (External: 5, Internal: 13)
- ◆ Input / Output ports (39 pins)
- ◆ 18-bit timer counter: 1 ch
 - Timer, Event counter, Pulse width measurement, Frequency measurement modes
- ◆ 8-bit timer counter: 4 ch
 - Timer, Event counter, PWM output, Programmable Divider Output PPG modes
- ◆ Time Base Timer
- ◆ Divider output function
- ◆ Watchdog Timer
 - Interrupt source / reset output (programmable)
- ◆ Serial interface
 - 8-bit UART / SIO: 1ch
- ◆ 10-bit successive approximation type A/D converter
 - Analog input: 8 ch

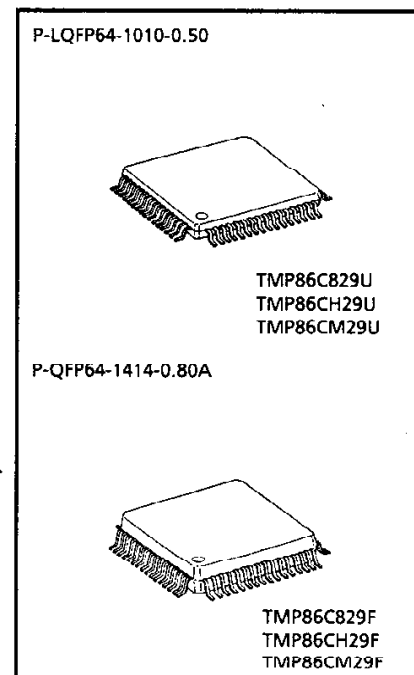

980910EBP1

- For a discussion of how the reliability of microcontrollers can be predicted, please refer to Section 1.3 of the chapter entitled Quality and Reliability Assurance / Handling Precautions.
- TOSHIBA is continually working to improve the quality and the reliability of its products. Nevertheless, semiconductor devices in general can malfunction or fail due to their inherent electrical sensitivity and vulnerability to physical stress. It is the responsibility of the buyer, when utilizing TOSHIBA products, to observe standards of safety, and to avoid situations in which a malfunction or failure of a TOSHIBA product could cause loss of human life, bodily injury or damage to property. In developing your designs, please ensure that TOSHIBA products are used within specified operating ranges as set forth in the most recent products specifications. Also, please keep in mind the precautions and conditions set forth in the TOSHIBA Semiconductor Reliability Handbook.
- The products described in this document are subject to the foreign exchange and foreign trade laws.
- The information contained herein is presented only as a guide for the applications of our products. No responsibility is assumed by TOSHIBA CORPORATION for any infringements of intellectual property or other rights of the third parties which may result from its use. No license is granted by implication or otherwise under any intellectual property or other rights of TOSHIBA CORPORATION or others.
- The information contained herein is subject to change without notice.

- ◆ Four Key On Wake Up pins
- ◆ LCD driver / controller
 - Built-in voltage booster for LCD driver
 - With display memory
 - LCD direct drive capability (Max 32 seg × 4 com)
 - 1/4, 1/3, 1/2 duties or static drive are programmably selectable
- ◆ Dual clock operation
 - Single / Dual-clock mode
- ◆ Nine power saving operating modes
 - STOP mode: Oscillation stops. Battery / Capacitor back-up. Port output hold / High-impedance.
 - SLOW 1, 2 mode: Low power consumption operation using low-frequency clock (32.768 kHz)
 - IDLE 0 mode: CPU stops, and peripherals operate using high-frequency clock of Time-Base-Timer. Release by INTTBT interrupt.
 - IDLE 1 mode: CPU stops, and peripherals operate using high-frequency clock. Release by interrupts.
 - IDLE 2 mode: CPU stops, and peripherals operate using high and low frequency clock. Release by interrupts.
 - SLEEP 0 mode: CPU stops, and peripherals operate using low-frequency clock of Time-Base-Timer. Release by INTTBT interrupt.
 - SLEEP 1 mode: CPU stops, and peripherals operate using low-frequency clock. Release by interrupts.
 - SLEEP 2 mode: CPU stops, and peripherals operate using high and low frequency clock. Release by interrupts.
- ◆ Wide operating voltage: 1.8 to 5.5 V at 4.2 MHz / 32.768 kHz,
2.7 to 5.5 V at 8 MHz / 32.768 kHz,
4.5 to 5.5 V at 16 MHz / 32.768 kHz

Pin Assignments (Top View)

P-LQFP64-1010-0.50
 P-QFP64-1414-0.80A

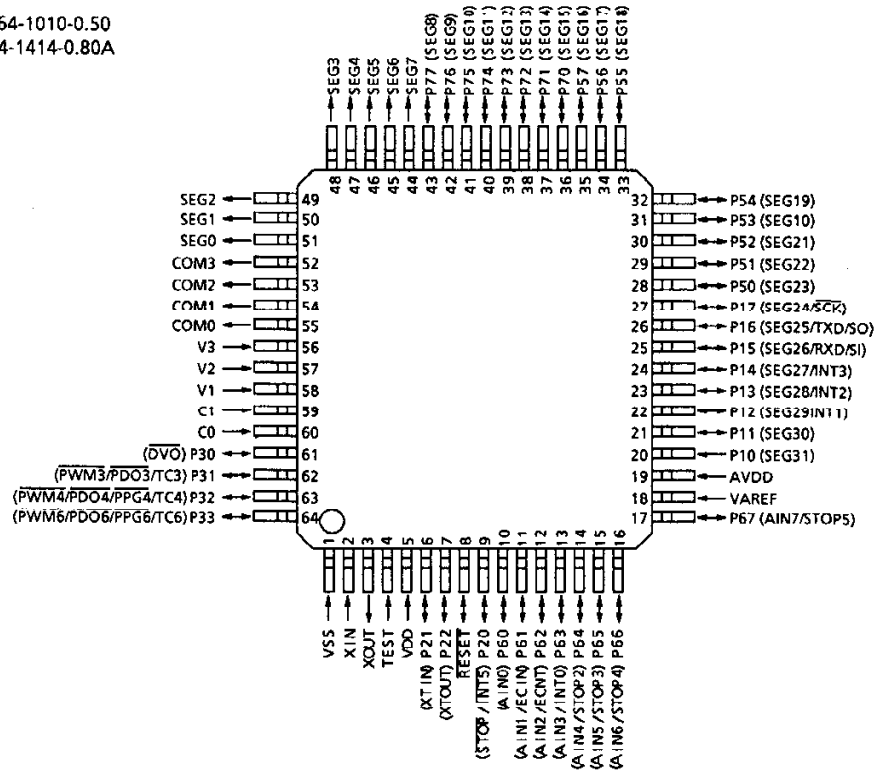

Block Diagram

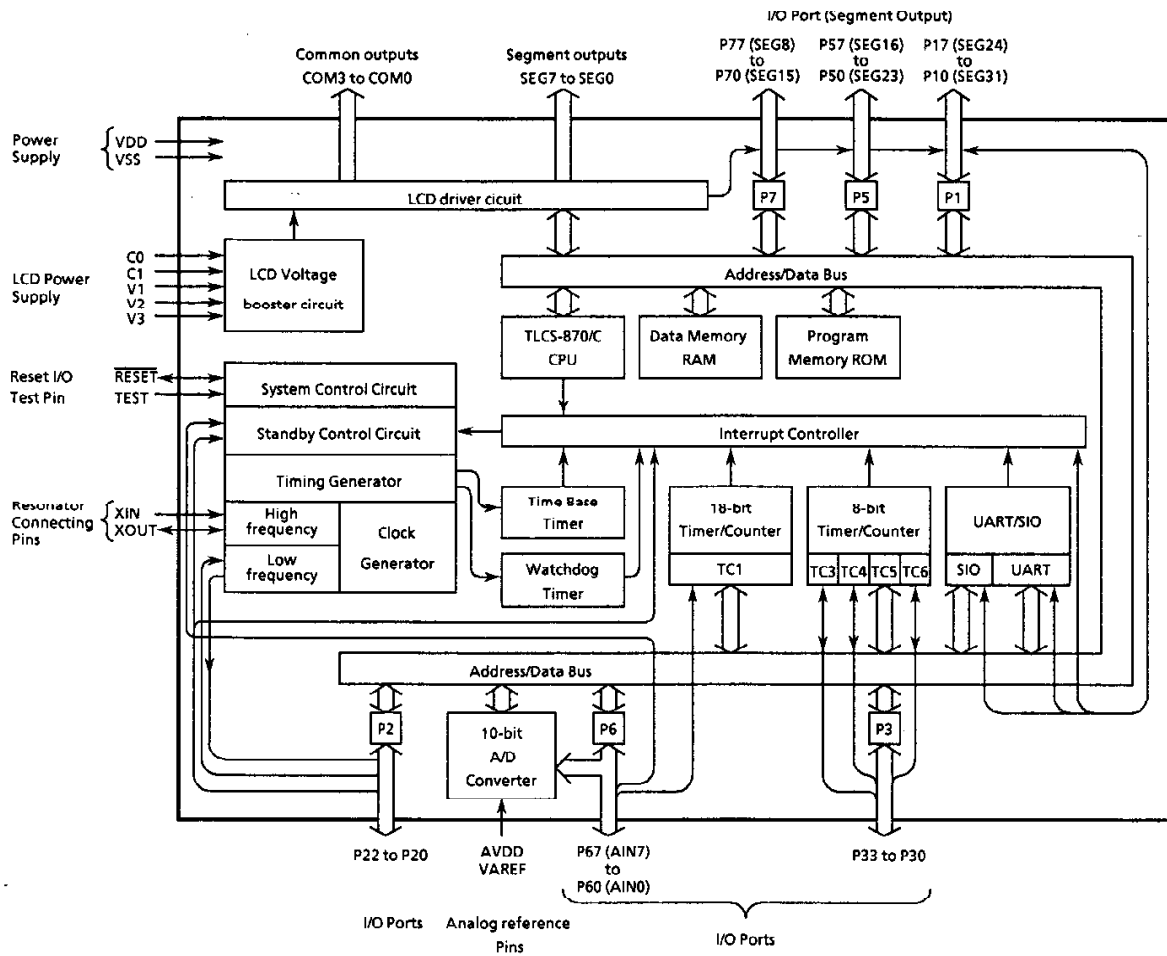

Pin Function

Pin Name	Input / Output	Function		
P17 (SEG24, \overline{SCK})	I/O (I/O)	8-bit input / output port with latch. When used as input port, an external interrupt input, serial clock input / output, serial data input / output and UART data input / output, the latch must be set to "1". When used as a LCD segment output, the P1LCR must be set to "1".	Serial clock input / output	
P16 (SEG25, TxD, SO)	I/O (I/O)		UART data output	
P15 (SEG26, RxD, SI)	I/O (I/O)		Serial data output	
P14 (SEG27, INT3)	I/O (I/O)		UART data input	
P13 (SEG28, INT2)	I/O (I/O)		Serial data input	
P12 (SEG29, INT1)	I/O (I/O)		External interrupt 3 input	
P11 (SEG30)	I/O (Output)		External Interrupt 2 Input	
P10 (SEG31)	I/O (Output)	External interrupt 1 input	LCD segment outputs.	
P22 (XTOUT)	I/O (Output)	3-bit input / output port with latch. When used as an input port, the latch must be set to "1".		Resonator connecting pins (32.768 kHz)
P21 (XTIN)	I/O (Input)			For inputting external clock, XTIN is used and XOUT is opened.
P20 (INT5, STOP)	I/O (Input)			External interrupt input 5 or STOP mode release signal input
P33 (PWM6, PDO6, PPG6, TC6)	I/O(I/O)	4-bit programmable input / output ports (high current output). Each bit of these ports can be individually configured as an input or an output under software control. When used as a timer / counter input, timer / counter output, a divider output, the latch must be set to "1".		8-bit (16-bit) PWM output, 8 (16) bit programmable divider output, 8 (16) bit PPG output, Timercounter 6 input
P32 (PWM4, PDO4, PPG4, TC4)	I/O(I/O)			8-bit PWM output, 8-bit programmable divider output, 16-bit PPG output, Timer counter 4 input
P31 (PWM3, PDO3, TC3)	I/O(I/O)			8-bit (16-bit) PWM output, 8 (16) programmable divider output, Timer counter 3 input
P30 (DVO)	I/O(Output)		Divider output	
P57 (SEG16) to P50 (SEG23)	I/O (Output)	8-bit input / output port with latch. When used as a LCD segment output, the P5LCR must be set to "1".	LCD segment outputs	
P67 (AIN7, STOP5)	I/O (Input)	8-bit programmable Input / output ports (tri-state). Each bit of these ports can be individually configured as an input or an output under software control. When used as a key on wake up input, an external interrupt input and timer / counter input, the P6CR must be set to "1".	Key on wake up input 5	
P66 (AIN6, STOP4)	I/O (Input)		Key on wake up input 4	
P65 (AIN5, STOP3)	I/O (Input)		Key on wake up input 3	
P64 (AIN4, STOP2)	I/O (Input)		Key on wake up input 2	
P63 (AIN3, INT0)	I/O (Input)		External interrupt input 0	
P62 (AIN2, ECNT)	I/O (Input)		Timer / counter 1 input	
P61 (AIN1, ECIN)	I/O (Input)			
P60 (AIN0)	I/O (Input)		A/D converter analog inputs	
P77 (SEG8) to P70 (SEG15)	I/O (Output)	8-bit input / output port with latch. When used as a LCD segment output, the P7LCR must be set to "1".		LCD segment outputs
SEG7 to SEG0	Output	LCD segment outputs		
COM3 to COM0		LCD common outputs		
V3 to V1 C1 to C0	LCD voltage booster pin	LCD voltage booster pin. Capacitors are required between C0 and C1 pin and V1/V2/V3 pin and GND.		
XIN, XOUT	Input Output	Resonator connecting pins for high-frequency clock. For inputting external clock, XIN is used and XOUT is opened.		
RESET	I/O	Reset signal input or watchdog timer output / address-trap-reset output		
TEST	Input	Test pin for out-going test. Be fixed to low.		
VDD, VSS	Power Supply	+ 5 V, 0 (GND)		
VAREF		Analog reference voltage inputs (High, Low)		
AVDD		+ 5 V, 0 (GND) A/D circuit power supply		