

# TB6615PG

## STEPPING MOTOR CONTROLLER / DRIVER

The TB6615PG is a stepping motor controller/driver with MOS output transistors.

The TB6615PG can drive a two-phase stepping motor in unipolar mode, and allow the selection of rotation direction between forward and reverse by using clock signals. It also supports several excitation modes (1-phase, 2-phase and 1-2-phase).

### FEATURES

- Single-chip stepping motor controller/driver
- All inputs are TTL level.
- The CK1, CK2, CW/CCW and  $\bar{R}$  pins are Schmitt trigger inputs.
- Rotation direction control (Clockwise (CW)/counterclockwise (CCW)): Single-clock and dual-clock modes
- Output enable and initial state detection capabilities
- High output withstand voltage:  $V_{CE(SUS)\phi} = 28\text{ V (MIN)}$
- High output current:  $I_{OUT\phi} = 400\text{ mA (MAX.)}$
- Package: DIP-16
- The overvoltage protection circuitry is provided on each output. (It is activated when the output voltage reaches 30 V (typ.) or higher.)

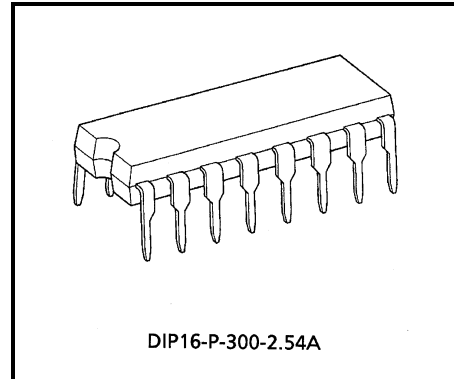

Weight : 1.11 g (typ.)

The TB6615PG is a Pb-free product.  
The following conditions apply to solderability:

\*Solderability

1. Use of Sn-37Pb solder bath
  - \*solder bath temperature = 230°C
  - \*dipping time = 5 seconds
  - \*number of times = once
  - \*use of R-type flux
2. Use of Sn-3.0Ag-0.5Cu solder bath
  - \*solder bath temperature = 245°C
  - \*dipping time = 5 seconds
  - \*the number of times = once
  - \*use of R-type flux



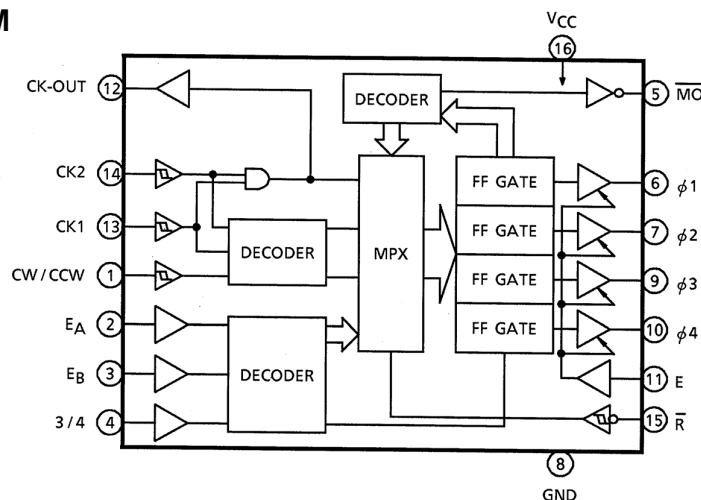





### BLOCK DIAGRAM



## PIN DESCRIPTION

PIN No.	SYMBOL	PIN NAME	FUNCTIONAL DESCRIPTION	
1	CW/CCW	Clockwise/Counterclockwise	Rotation Direction Select Input (See Truth Table A.)	
2	E <sub>A</sub>	Excitation A	Excitation Mode Select Input	See Truth Table B.
3	E <sub>B</sub>	Excitation B		
4	3/4	3 Phases/4 Phases		
5	$\overline{MO}$	Monitor Out	Initial State Detection Output; this pin is set Low in the initial state.	
6	$\phi 1$	$\phi 1$ Out	$\phi 1$ Output	
7	$\phi 2$	$\phi 2$ Out	$\phi 2$ Output	
8	GND	GND	Ground	
9	$\phi 3$	$\phi 3$ Out	$\phi 3$ Output	
10	$\phi 4$	$\phi 4$ Out	$\phi 4$ Output	
11	E	Output Enable	Outputs $\phi 1$ through $\phi 4$ are enabled when this pin is High.	
12	CK-OUT	Clock-Out	Clock Output	
13	CK1	Clock I <sub>n</sub> -1	Clock Input 1	See Truth Table A.
14	CK2	Clock I <sub>n</sub> -2	Clock Input 2	
15	$\overline{R}$	Reset	Reset Input; outputs are reset when this pin is Low (Note 1)	
16	V <sub>CC</sub>	V <sub>CC</sub>	V <sub>CC</sub>	

### TRUTH TABLE A

CK1	CK2	CW/CCW	FUNCTION
	H	L	CW
	L	L	Inhibit (Note 2)
H		L	CCW
L		L	Inhibit (Note 2)
	H	H	CCW
	L	H	Inhibit (Note 2)
H		H	CW
L		H	Inhibit (Note 2)

### TRUTH TABLE B

E <sub>A</sub>	E <sub>B</sub>	3/4 (Note 3)	FUNCTION	
L	L	L	4-Phase Output	1-Phase Excitation
H	L	L		2-Phase Excitation
L	H	L		1-2-Phase Excitation
H	H	L	Test Mode: All outputs are enabled	
L	L	H	3-Phase Output	1-Phase Excitation
H	L	H		2-Phase Excitation
L	H	H		1-2-Phase Excitation
H	H	H	Test Mode: All outputs are enabled.	

Note 1: Setting the Reset pin Low causes the output state to enter the initial state, and the  $\overline{MO}$  output to become Low.

Once the Reset pin is set High, the output state enters the state following the initial state at the next rising edge of the clock signal.

Note 2: Do not use Inhibit mode.

Note 3: Before switching the 3/4, E<sub>A</sub> and/or E<sub>B</sub> pins, put the TB6615PG into Reset mode by applying the Reset pulse.

Note 4: A two-phase stepping motor should be driven in four-phase output mode.

## EQUIVALENT CIRCUITS

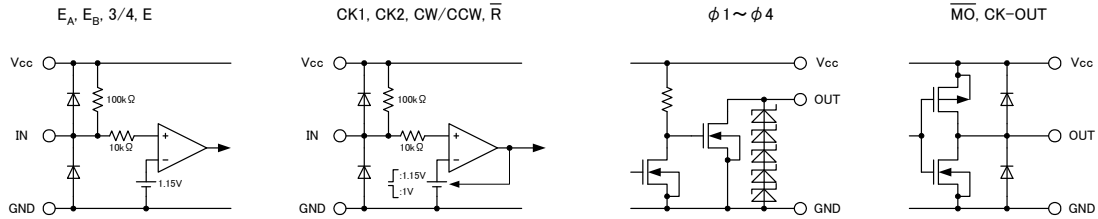

## ABSOLUTE MAXIMUM RATINGS (Ta = 25°C)

CHARACTERISTICS	SYMBOL	RATING	UNIT
Supply Voltage	V <sub>CC</sub>	-0.3 to 7.0	V
Output Withstanding Voltage	V <sub>CE(SUS)</sub> φ	-0.3 to 28	V
Output Current (φn)	I <sub>OUT</sub> φ	400	mA
Output Current (M0, CK-OUT)	I <sub>OUT</sub> M0 CK-OUT	10	mA
Input Voltage	V <sub>IN</sub>	-0.3 to V <sub>CC</sub> + 0.3	V
Input Current	I <sub>IN</sub>	±1	mA
Power Dissipation	P <sub>D</sub>	1.8	W
Operating Temperature	T <sub>opr</sub>	-30 to 85	°C
Storage Temperature	T <sub>stg</sub>	-55 to 150	°C

## OPERATION RANGE (Ta = 25°C)

CHARACTERISTICS	SYMBOL	TEST CONDITIONS	MIN	TYP.	MAX	UNIT
Supply Voltage	V <sub>CC</sub>	—	2.7	5.0	5.5	V
Output Withstanding Voltage	V <sub>CE(SUS)</sub> φ	—	0	—	26	V
Output Current φn	I <sub>OUT</sub> φ	Low	—	—	200	mA
Output Current M0, CK-OUT		High	—	—	-0.4	mA
	Low	—	—	8		
Input Voltage	V <sub>IN</sub>	—	0	—	V <sub>CC</sub>	V
Clock Frequency	f <sub>CLOCK</sub>	—	0	—	100	kHz

## ELECTRICAL CHARACTERISTICS (Ta = 25°C)

CHARACTERISTICS		SYMBOL	TEST CIR-CUIT	TEST CONDITIONS	MIN	TYP.	MAX	UNIT	
Input Voltage	High	V <sub>IH</sub>	—	—	2.0	—	—	V	
	Low	V <sub>IL</sub>	—	—	—	—	0.8		
Input Current	High	I <sub>IH</sub>	—	V <sub>CC</sub> = 5.5 V, V <sub>IH</sub> = 5.5 V	—	—	2	μA	
	Low	I <sub>IL</sub>	—	V <sub>CC</sub> = 5.5 V, V <sub>IL</sub> = 0.4 V	—	—	-0.15	mA	
Hysteresis Voltage		ΔV <sub>T</sub>	—	V <sub>CC</sub> = 5.0 V	—	150	—	mV	
Current Consumption		I <sub>CC</sub>	—	V <sub>CC</sub> = 5.5 V	—	—	27	mA	
Output Leakage Current φn		I <sub>OHφ</sub>	—	V <sub>CC</sub> = 5.5 V, V <sub>OUT</sub> = 26 V	—	—	1	μA	
Output Voltage	High	$\overline{MO}$ CK-OUT	V <sub>OH</sub>	—	V <sub>CC</sub> = 2.7 V, I <sub>OH</sub> = -0.4 mA	(V <sub>CC</sub> × 0.8)	—	V	
	Low	$\overline{MO}$ CK-OUT	V <sub>OL</sub>	—	V <sub>CC</sub> = 2.7 V, I <sub>OL</sub> = 8 mA	—	—		(V <sub>CC</sub> × 0.2)
		φn	V <sub>OUTφ</sub>	—	V <sub>CC</sub> = 2.7 V, I <sub>OUT</sub> = 400 mA t = 100 ms	—	—		0.8
					V <sub>CC</sub> = 2.7 V, I <sub>OUT</sub> = 200 mA t = 100 ms	—	—		0.5

## SWITCHING CHARACTERISTICS (Ta = 25°C)

CHARACTERISTICS		SYMBOL	TEST CIR-CUIT	TEST CONDITIONS	MIN	TYP.	MAX	UNIT	
Propagation Delay	High	CK-φn	t <sub>pLH</sub>	—	Design target only	—	200	—	ns
		CK-CK-OUT				—	100	—	
		CK- $\overline{MO}$				—	150	—	
		E-φn				—	200	—	
		$\overline{R}$ -φn				—	200	—	
	Low	CK-φn	t <sub>pHL</sub>	—	Design target only	—	200	—	
		CK-CK-OUT				—	110	—	
		CK- $\overline{MO}$				—	150	—	
		E-φn				—	200	—	
		$\overline{R}$ -φn				—	200	—	
		$\overline{R}$ - $\overline{MO}$				—	110	—	
	Maximum Operating Frequency		f <sub>max</sub>	—	Design target only	—	250	—	
Setup Time (CK, CW/CCW)		t <sub>set-up</sub>	—	Design target only	—	10	—	ns	
Hold Time (CK, CW/CCW)		t <sub>hold</sub>			—	10	—		
Minimum Clock Pulse Width		t <sub>w</sub> (CK)	—	Design target only	—	100	—		
Minimum Reset Pulse Width		t <sub>w</sub> ( $\overline{R}$ )	—	Design target only	—	100	—		
Maximum Clock Rise Time		t <sub>r</sub> (CK)	—	Design target only	—	2	—		μs

## TIMING CHARTS

### THREE-PHASE OUTPUT MODES

**1-PHASE EXCITATION (CW)**

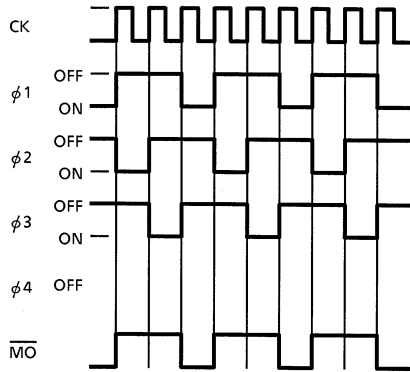

**1-PHASE EXCITATION (CCW)**

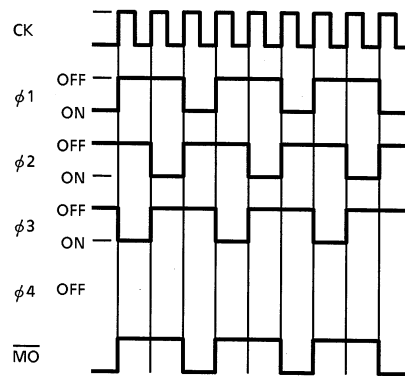

**2-PHASE EXCITATION (CW)**

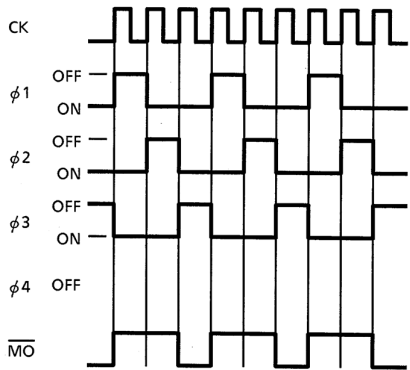

**2-PHASE EXCITATION (CCW)**

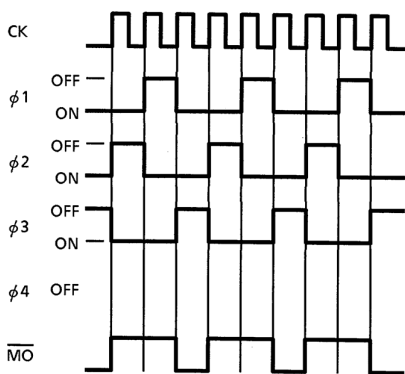

**1-2-PHASE EXCITATION (CW)**

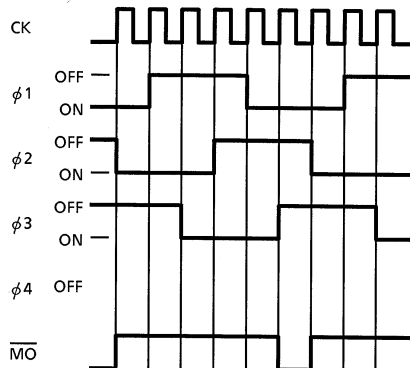

**1-2-PHASE EXCITATION (CCW)**

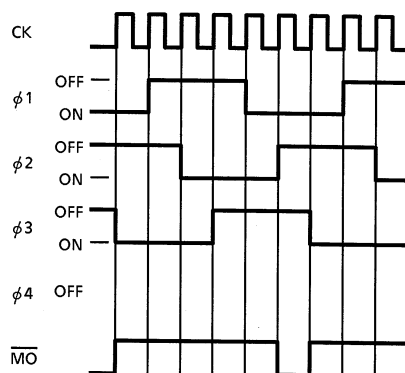

**FOUR-PHASE OUTPUT MODES**

**1-PHASE EXCITATION (CW)**

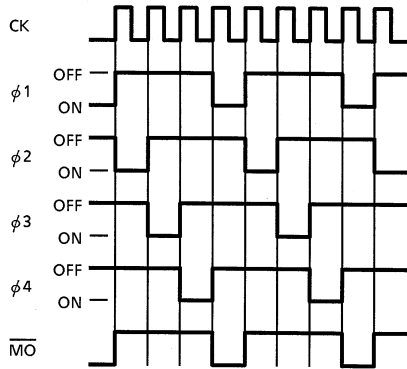

**1-PHASE EXCITATION (CCW)**

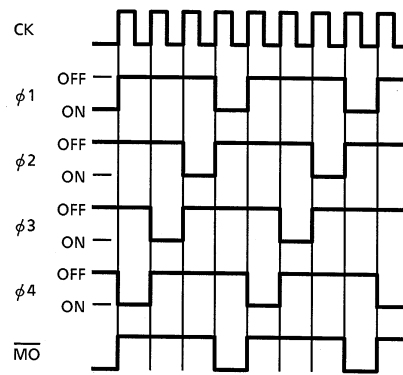

**2-PHASE EXCITATION (CW)**

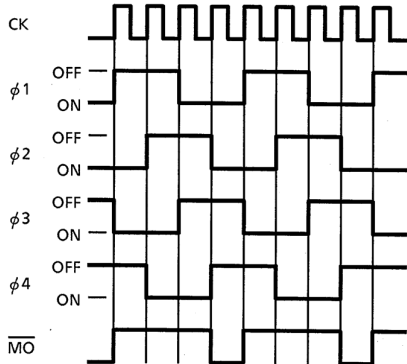

**2-PHASE EXCITATION (CCW)**

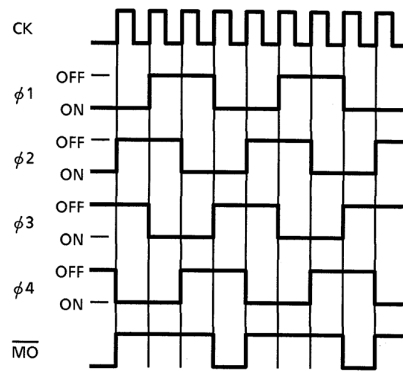

**1-2-PHASE EXCITATION (CW)**

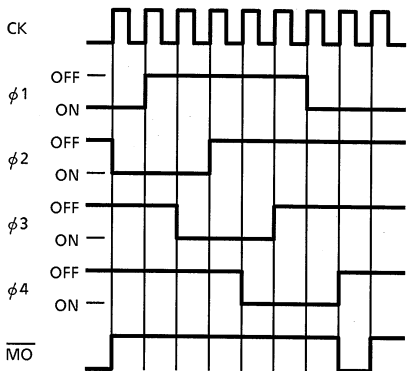

**1-2-PHASE EXCITATION (CCW)**

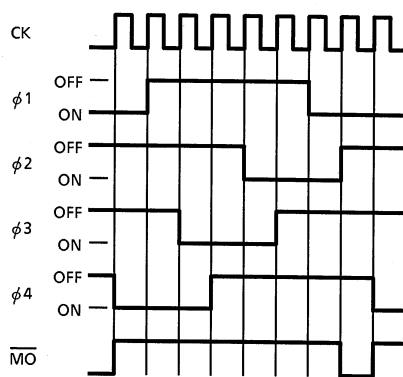

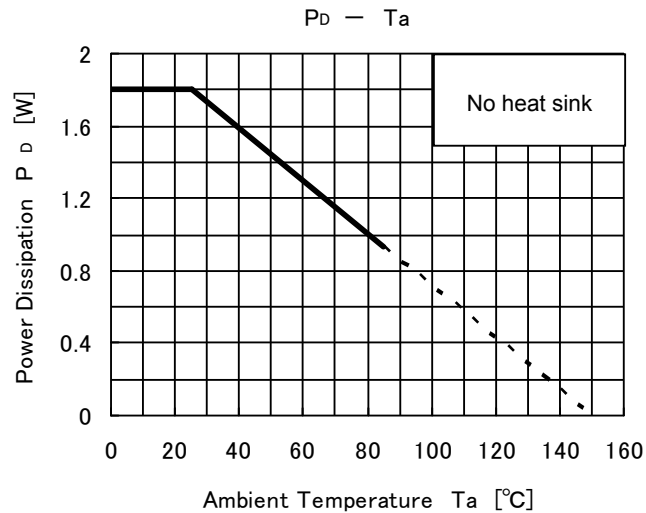

#### Usage Considerations

- The IC may be destroyed in case of a short-circuit across outputs, a short-circuit to power supply or a short-circuit to ground. This possibility should be fully considered in the design of the output,  $V_{CC}$  and ground lines.
- It should be ensured that the device is inserted properly. The IC may be damaged if it is inserted in the wrong orientation.
- If the device is damaged, a large current may continue to flow through the motor driver stage as a secondary effect. Therefore, Toshiba recommends that a fuse be connected to the power supply line at the driver stage.

## Application Circuit Example 1

TB6615PG+TD62308BP-1

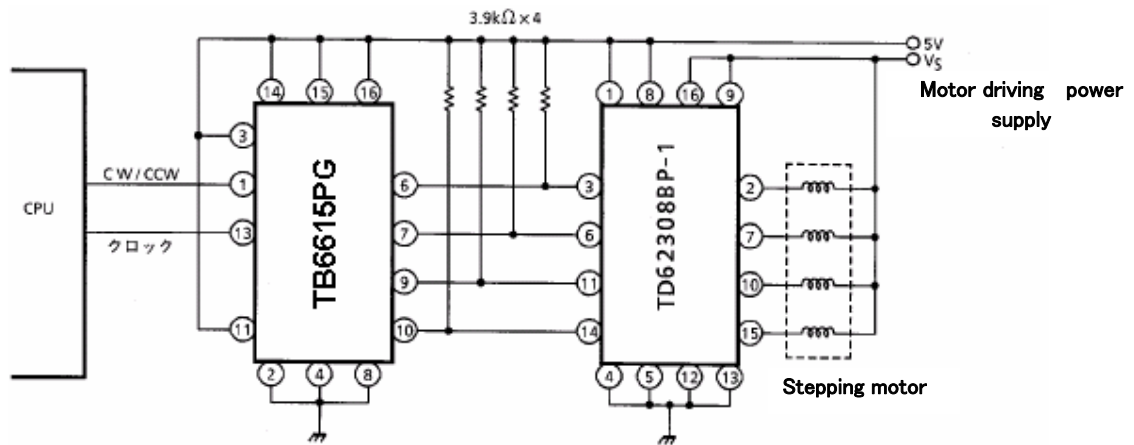

## Application Circuit Example 2

TB6615G+TD62553S+MP4001

This circuit operates with two power supplies.

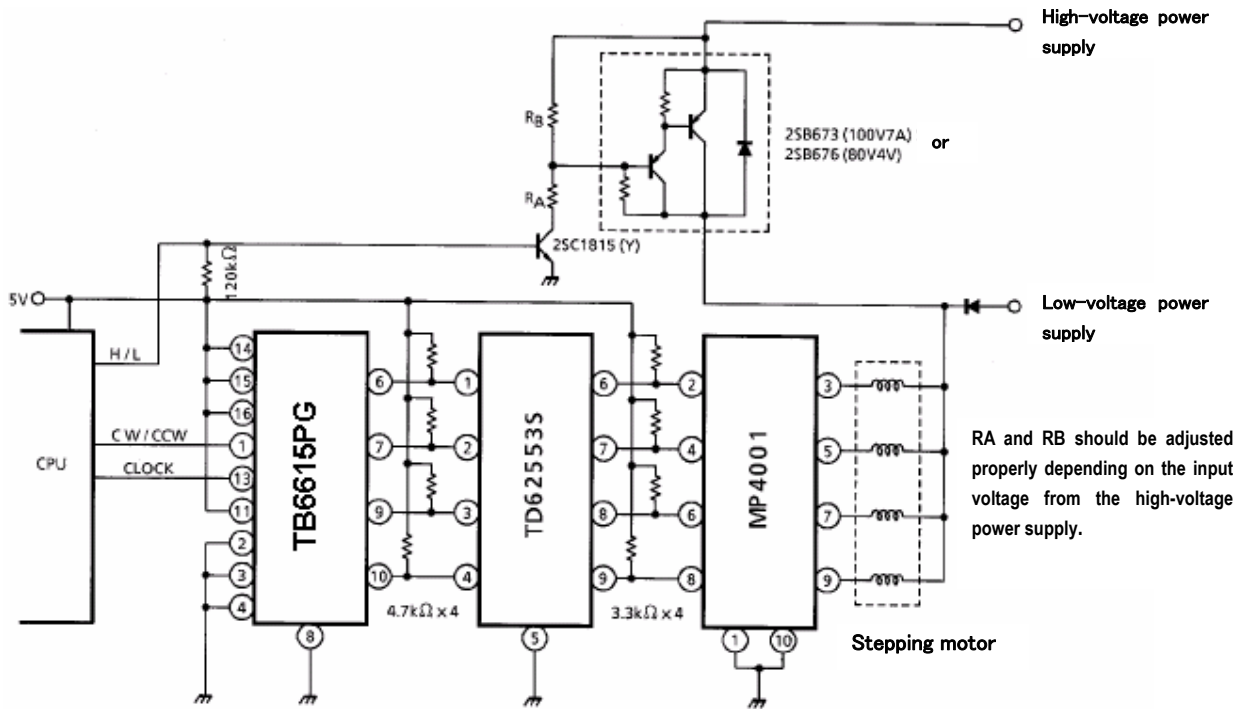



**Application Circuit Example 3**

1-2-phase excitation system for a two-phase motor, I

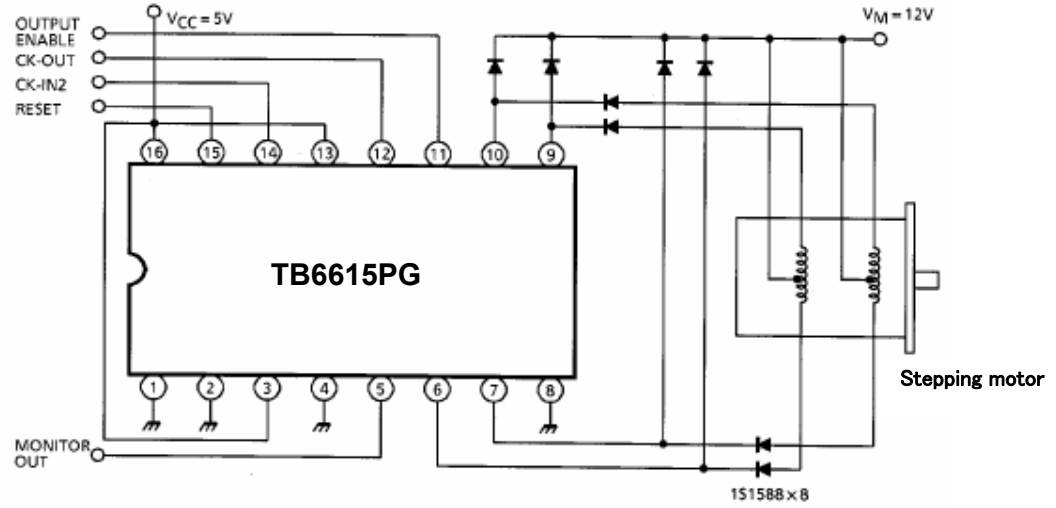

• When an inductive kick of the motor is large, the snubber diodes should be placed across the coil to suppress the inductive kick. (This also applies to Application Circuit Example 4.)

**Application Circuit Example 4**

1-2-phase excitation system for a two-phase motor, II

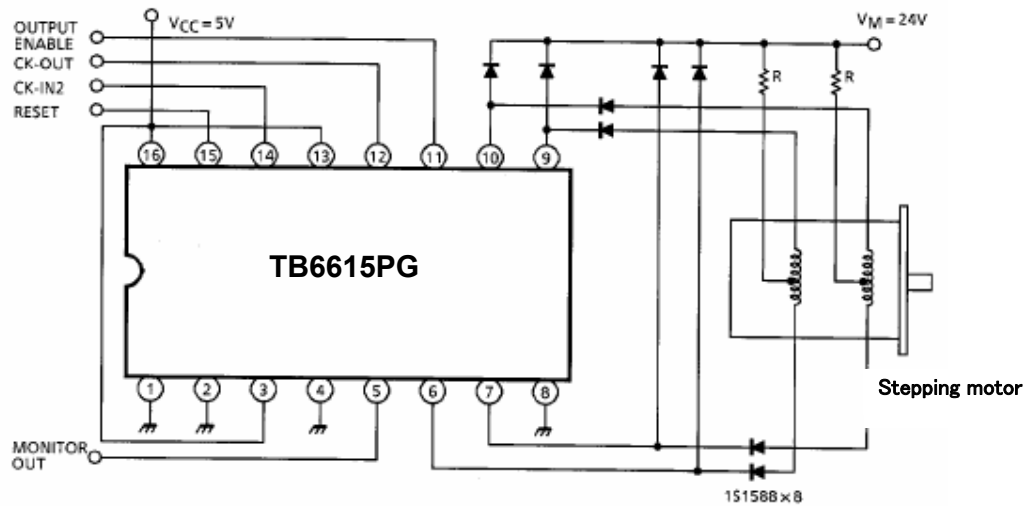

Note: The IC may be destroyed in case of a short-circuit across outputs, a short-circuit to power supply or a short-circuit to ground. This possibility should be fully considered in the design of the output, V<sub>CC</sub> (V<sub>M</sub>, V<sub>S</sub> and V<sub>EE</sub>) and ground lines.

## PACKAGE DIMENSIONS

DIP16-P-300-2.54A

Unit: mm

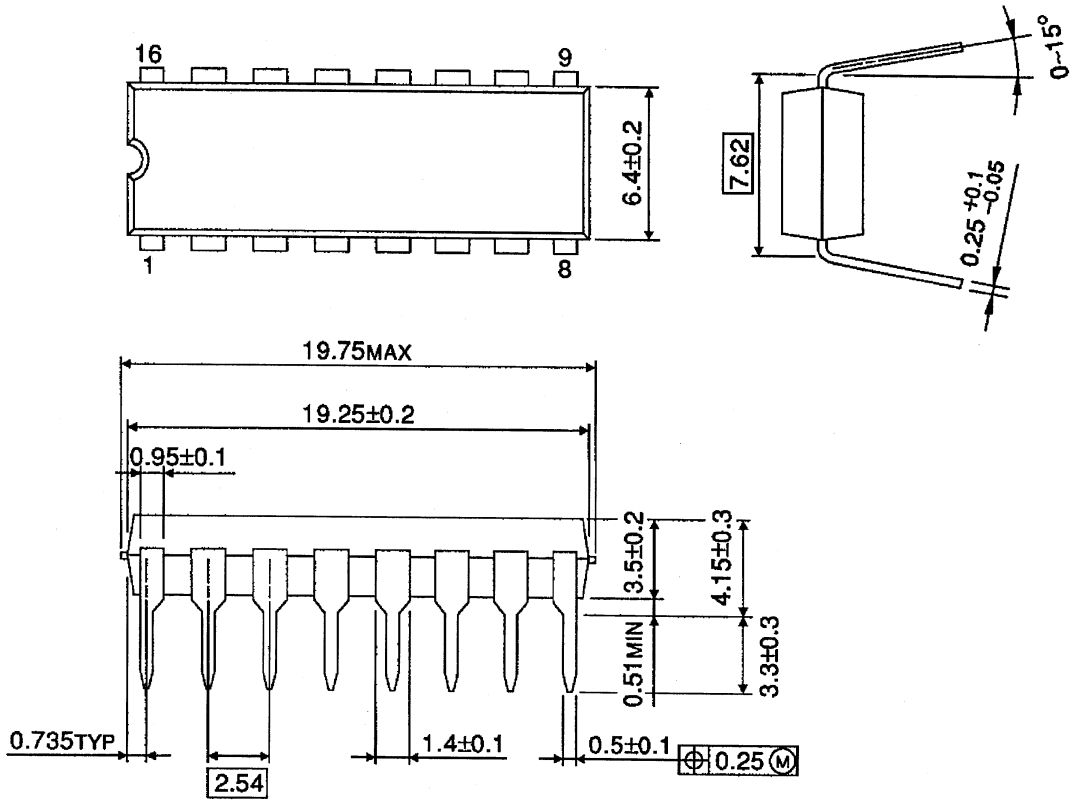

Weight: 1.11g (typ.)

**Notes on Contents****1. Block Diagrams**

Some of the functional blocks, circuits, or constants in the block diagram may be omitted or simplified for explanatory purposes.

**2. Equivalent Circuits**

The equivalent circuit diagrams may be simplified or some parts of them may be omitted for explanatory purposes.

**3. Timing Charts**

Timing charts may be simplified for explanatory purposes.

**4. Application Circuits**

The application circuits shown in this document are provided for reference purposes only. Thorough evaluation is required, especially at the mass production design stage.

Toshiba does not grant any license to any industrial property rights by providing these examples of application circuits.

**5. Test Circuits**

Components in the test circuits are used only to obtain and confirm the device characteristics. These components and circuits are not guaranteed to prevent malfunction or failure from occurring in the application equipment.

**IC Usage Considerations****Notes on handling of ICs**

- [1] The absolute maximum ratings of a semiconductor device are a set of ratings that must not be exceeded, even for a moment. Do not exceed any of these ratings.  
Exceeding the rating(s) may cause the device breakdown, damage or deterioration, and may result injury by explosion or combustion.
- [2] Use an appropriate power supply fuse to ensure that a large current does not continuously flow in case of over current and/or IC failure. The IC will fully break down when used under conditions that exceed its absolute maximum ratings, when the wiring is routed improperly or when an abnormal pulse noise occurs from the wiring or load, causing a large current to continuously flow and the breakdown can lead smoke or ignition. To minimize the effects of the flow of a large current in case of breakdown, appropriate settings, such as fuse capacity, fusing time and insertion circuit location, are required.
- [3] If your design includes an inductive load such as a motor coil, incorporate a protection circuit into the design to prevent device malfunction or breakdown caused by the current resulting from the inrush current at power ON or the negative current resulting from the back electromotive force at power OFF. IC breakdown may cause injury, smoke or ignition.  
Use a stable power supply with ICs with built-in protection functions. If the power supply is unstable, the protection function may not operate, causing IC breakdown. IC breakdown may cause injury, smoke or ignition.
- [4] Do not insert devices in the wrong orientation or incorrectly.  
Make sure that the positive and negative terminals of power supplies are connected properly. Otherwise, the current or power consumption may exceed the absolute maximum rating, and exceeding the rating(s) may cause the device breakdown, damage or deterioration, and may result injury by explosion or combustion.  
In addition, do not use any device that is applied the current with inserting in the wrong orientation or incorrectly even just one time.

**Points to remember on handling of ICs****(1) Overcurrent Protection Circuit**

Overcurrent protection circuits (referred to as current limiter circuits) do not necessarily protect ICs under all circumstances. If the Over current protection circuits operate against the over current, clear the over current status immediately.

Depending on the method of use and usage conditions, such as exceeding absolute maximum ratings can cause the over current protection circuit to not operate properly or IC breakdown before operation. In addition, depending on the method of use and usage conditions, if over current continues to flow for a long time after operation, the IC may generate heat resulting in breakdown.

**(2) Heat Radiation Design**

In using an IC with large current flow such as power amp, regulator or driver, please design the device so that heat is appropriately radiated, not to exceed the specified junction temperature ( $T_j$ ) at any time and condition. These ICs generate heat even during normal use. An inadequate IC heat radiation design can lead to decrease in IC life, deterioration of IC characteristics or IC breakdown. In addition, please design the device taking into consideration the effect of IC heat radiation with peripheral components.

**(3) Back-EMF**

When a motor rotates in the reverse direction, stops or slows down abruptly, a current flow back to the motor's power supply due to the effect of back-EMF. If the current sink capability of the power supply is small, the device's motor power supply and output pins might be exposed to conditions beyond maximum ratings. To avoid this problem, take the effect of back-EMF into consideration in system design.

**RESTRICTIONS ON PRODUCT USE**

20070701-EN

- The information contained herein is subject to change without notice.
- TOSHIBA is continually working to improve the quality and reliability of its products. Nevertheless, semiconductor devices in general can malfunction or fail due to their inherent electrical sensitivity and vulnerability to physical stress. It is the responsibility of the buyer, when utilizing TOSHIBA products, to comply with the standards of safety in making a safe design for the entire system, and to avoid situations in which a malfunction or failure of such TOSHIBA products could cause loss of human life, bodily injury or damage to property.  
In developing your designs, please ensure that TOSHIBA products are used within specified operating ranges as set forth in the most recent TOSHIBA products specifications. Also, please keep in mind the precautions and conditions set forth in the "Handling Guide for Semiconductor Devices," or "TOSHIBA Semiconductor Reliability Handbook" etc.
- The TOSHIBA products listed in this document are intended for usage in general electronics applications (computer, personal equipment, office equipment, measuring equipment, industrial robotics, domestic appliances, etc.). These TOSHIBA products are neither intended nor warranted for usage in equipment that requires extraordinarily high quality and/or reliability or a malfunction or failure of which may cause loss of human life or bodily injury ("Unintended Usage"). Unintended Usage include atomic energy control instruments, airplane or spaceship instruments, transportation instruments, traffic signal instruments, combustion control instruments, medical instruments, all types of safety devices, etc.. Unintended Usage of TOSHIBA products listed in this document shall be made at the customer's own risk.
- The products described in this document shall not be used or embedded to any downstream products of which manufacture, use and/or sale are prohibited under any applicable laws and regulations.
- The information contained herein is presented only as a guide for the applications of our products. No responsibility is assumed by TOSHIBA for any infringements of patents or other rights of the third parties which may result from its use. No license is granted by implication or otherwise under any patents or other rights of TOSHIBA or the third parties.
- Please contact your sales representative for product-by-product details in this document regarding RoHS compatibility. Please use these products in this document in compliance with all applicable laws and regulations that regulate the inclusion or use of controlled substances. Toshiba assumes no liability for damage or losses occurring as a result of noncompliance with applicable laws and regulations.
- The products described in this document are subject to foreign exchange and foreign trade control laws.